

U-SCAN[®]

MAX[™]

Single Station



System Description and Service Guide

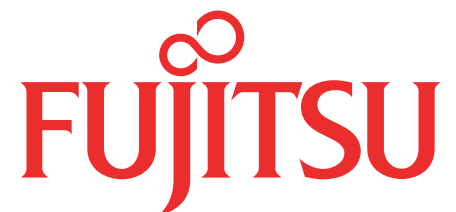

FUJITSU

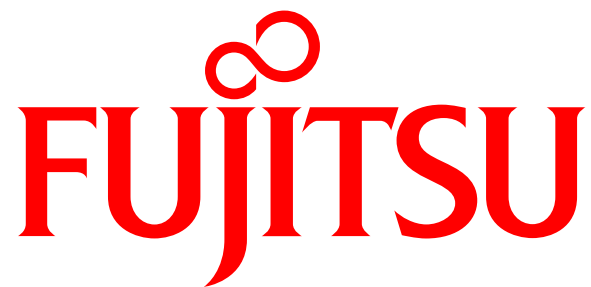

Title:	U-Scan® Max Single Belt System Description and Service Guide
Date:	February 2, 2007
Audience:	Field Engineers
Update:	Version 10

©2006-07 FUJITSU TRANSACTION SOLUTIONS INC. ALL RIGHTS RESERVED. U-SCAN GENESIS, U-SCAN EXPRESS, U-SCAN CAROUSEL, U-SCAN SOLO, U-SCAN COMPACT CASHIER, U-SCAN MOBILE ATTENDANT, IT'S THAT SIMPLE AND SCAN PAY GO AND ASSOCIATED LOGOS ARE TRADEMARKS OR REGISTERED TRADEMARKS OF FUJITSU TRANSACTION SOLUTIONS INC. ALL OTHER BRANDS AND PRODUCTS MENTIONED MAY BE TRADEMARKS OF THEIR RESPECTIVE HOLDER(S).

Contents

Introduction

Organization 1
Document Updates..... 2
Other Resources..... 4

System Overview

U-Scan Max Single Belt Station..... 5
 U-Scan Max Components..... 5
 Controller Board Panel..... 5
 Input Belt..... 6
 Sensor Arrays..... 6
 Front and Rear Guards..... 7
 Take-Away Belt..... 7
 Take-Away Belt Sensor..... 7
 Collection Area Sensor..... 7

Software Behavior

Maintenance Mode Belt Maintenance 9
U-Scan Max Single Belt Security..... 10
 Security System Components..... 10
 U-Scan Max Messages 10
 “Check Belts” Message..... 10
 “Lane Must be Clear” Message..... 12
 “Lane Full, Please Help Bag Items” Message..... 12
 “Lane Idle, Order Not Tendered” Message..... 13
 Security Process..... 15
 Sensor Array Violation..... 16
 Light Items Handling..... 16
 New Items Handling..... 16
Optional Software Features 18
 Double-Handed Scanning..... 18
 Attendant Mode Behavior for the U-Scan Max Single Belt Station 18

U-Scan Max Hardware Basics

U-Scan Max Single Belt Dimensions..... 20
 Service Clearance..... 20

U-Scan Max Single Belt Devices	21
Casing	22
Grounding	23
Controller Board Grounding	23
Main Unit Grounding	24
Conveyor Unit Grounding	24
BANNER Sensor Array Grounding	25
Cables	26
Cable Assignments	26
Cable Connections	26
Cable Harness	26
Controller Board	26
BANNER Sensor Array (Casing Version “D” and Later).....	27
SCANGINEER Sensor Array (Casing Version “C” and Earlier)	27
Cable Routing	28
Main Unit Cables - Overview	28
Conveyor Module Cables - Overview	29
Cable Routing Between the Modules	32
BANNER Sensor Array Cables.....	33
SCANGINEER Sensor Array Cables.....	33
Input Belt Motor Cable.....	33
Cables Inside the Pedestal	34
Communication Cable Assignments.....	35
Power Bar Assignments.....	36
U-Scan Max Maintenance	
End-User (Attendant) Maintenance	38
Cleaning the U-Scan Max.....	38
Cleaning Solution	38
Daily Cleaning	38
Other Cleaning.....	39
Field Maintenance and Service Overview	41
Conveyor Belts	41
Belt Component Replacement	41
Belt Position.....	41
Belt Tension and Tracking.....	42
Transfer Bar	43
Sensor Array	44
BANNER Sensor Array (Casing Version “D” and Later).....	45
SCANGINEER Sensor Array (Casing Version “C” and Earlier)	47
Take-Away and Collection Area Sensors.....	47
Preventive Maintenance for Field Engineers.....	48
Conveyor Belts	48
End-Access Plate	48
Sensor Array Pillars	48

U-Scan Max Hardware Testing

Hardware Operating Instructions.....	51
Testing the Belt Devices from the Controller Board.....	52
Testing the Belt Devices in the Device Tester.....	53
Check the Settings.....	53
Test the Overall Functionality.....	53
Test the Input Belt (Movement).....	56
Test the Take-Away Belt.....	57
Test the Sensors.....	57
Test the Input Belt Scale.....	58

U-Scan Max Hardware Troubleshooting

Zeroing the Input Belt Scale.....	62
Performing a Hard Zero Through HyperTerminal.....	62
Performing a Soft Zero Through Device Tester.....	63
Calibrating the Input Belt Scale.....	64
Calibrating the Input Belt Scale through HyperTerminal - Auto-Calibration Method.....	64
Calibrating the Input Belt Scale through HyperTerminal - Manual Calibration with Weights.....	66
Setting the Input Belt Scale Filter Settings.....	68
Verifying the Elevation and Latitude.....	70
Determining Latitude.....	71
Determining Elevation.....	71
Adjusting the Belt Devices.....	73
Adjusting the Belt Tension and Tracking.....	73
Remove the Front Guard Plate or End-Access Plate (As Required).....	73
Remove the External Printer Shelf (If Necessary).....	74
Adjust the Belt Tension and Tracking.....	75
Reassemble the Unit.....	76
Adjusting the Transfer Bar Height.....	77
Remove the Front and Rear Guards Beside the Take-Away Belt.....	77
Remove the Sensor Faceplates.....	78
Remove the Front and Rear Skirts Beside the Take-Away Belt.....	78
Adjust the Transfer Plate Height.....	78
Reassemble the Unit.....	80
Adjusting the Belt Position (Front-Back).....	81
Adjusting the Belt Height.....	82
Adjusting the Sensors.....	84
Adjusting the BANNER Sensor Array (Later Model “E” Casings).....	86
Access the Adjustment Bolts.....	88
Vertical Adjustment.....	89
Pivoting the Detection Sticks (Forward/Backward).....	90
Pivoting the Detection Sticks (Side to Side).....	94
Adjusting the BANNER Sensor Array (Casing Models “D” and Early “E” Casings).....	98
Adjusting the SCANGINEER Sensor Array (Casing Models “C” and Earlier).....	101

Remove the Sensor Faceplate	101
Test a 3/16" Object	101
Test a 1/8" Object	102
Recalibrate the Sensor Array	103
Perform a Final Test	103
Adjusting the Take-Away Belt Sensor - Casing Version "C" and Later	104
Adjusting the Take-Away Belt Sensor - Casing Version "B" and Earlier	105
Access the Take-Away Belt Sensor	105
Adjust the Sensor	105
Replace the Sensor	105
Test the Sensor	106
Adjusting the Collection Area Sensor	107

U-Scan Max Component Replacement

Replacing the Sensors	111
Replacing the BANNER Sensor Arrays (Later Casing Version "E")	111
Shut Down the U-Scan Max Single Station	111
Remove the Faulty BANNER Stick	112
Install the Replacement BANNER Stick	112
Adjust the BANNER Sensor Array	114
Replacing the BANNER Sensor Arrays (Casing Version "D" and Early Casing Version "E")	115
Remove the Detection Stick	115
Install the Detection Stick	116
Replacing the SCANGINEER Sensor Arrays (Casing Version "C" and Earlier)	118
Replacing the Receiver Circuit Board	118
Replacing the Transmitter Circuit Board	120
Replacing the Take-Away Belt Sensor (Casing Versions "C" and Later)	122
Replacing the Take-Away Belt Sensor (Casing Versions "B" and Earlier)	124
Remove the Take-Away Belt Sensor	124
Replace the Take-Away Belt Sensor	124
Replacing the Collection Area Sensor	125
Accessing the Belt Components	127
Remove the Front and Rear Guards	127
Remove the Sensor Faceplates	128
Remove the Front Guard Plate or End-Access Plate	128
Remove the Front and Rear Skirts	130
Disconnect the Belt Motor Cable (If Replacing Motor)	130
Remove the Top Nuts	131
Remove the Nuts or Bolts Securing One Side of the Frame	132
Lift One Side of the Belt Frame	132
Remove the Belt Bed(s)	133
Replacing the Belt Components	134
Replacing the Belt Motor	134
Power Down the Station	134
Access the Belt Motor	134
Remove the Ground Cable	135
Remove the Motor	135

Install the New Motor	136
Reassemble the Unit	136
Replacing the Idler	138
Power Down the Station	138
Access the Belt Idler	138
Remove the Idler	138
Replace the Idler	138
Reassemble the Unit	139
Replacing the Belt	139
Replacing a Belt Scale Load Cell	140
Replacing the SCALETRON CPU (Scale Brain)	143
Replacing the Controller Board Fuse	144
Replacing the Controller Board	145
Remove the Controller Board	145
Install the New Controller Board	146
Complete the Procedure	147
Crimping the Cables	148
Crimping the Communication Cables	148
Crimping the Ground Cables	149
Cable Pin Assignments	151
Replacing the SCANGINEER Sensor Array Wires in the Cable Connection Head	153
Wiring Schematics	
Controller Wiring Diagram	155
Cable Wiring Diagrams	156
Cable Harness	156
BANNER Light Curtain Cable Assembly	157
Take-Away Belt (Cable Y) and Collection Area (Cable Z) Sensors	157
Input Belt Motor (Cable V) or Take-Away Belt Motor (Cable W)	157

Introduction

This document describes the generic U-Scan® Max Single Belt system. This document contains hyperlinks (in blue) and is best viewed in PDF format.



The information in this document has not yet been finalized. All information and procedures are subject to change.

Organization

This document includes the following information:

- [System Overview](#) (page 5): Provides an illustration of the system and a description of the components.
- [Software Behavior](#) (page 9): Provides a description of basic end-user system functionality.
- [U-Scan Max Hardware Basics](#) (page 19): Illustrated overview of the U-Scan Max casing.
- [U-Scan Max Maintenance](#) (page 37): Cleaning and maintenance for U-Scan attendants and field engineers. Includes preventive maintenance for field engineers.
- [U-Scan Max Hardware Testing](#) (page 51): Procedures for testing the devices unique to the U-Scan Max through the controller board switches and through the **Device Tester**.
- [U-Scan Max Hardware Troubleshooting](#) (page 61): Procedures for adjusting the U-Scan Max devices. Includes the input belt scale calibration procedure.
- [U-Scan Max Component Replacement](#) (page 109): Procedures for replacing the U-Scan Max components.
- [Wiring Schematics](#) (page 155): Wiring drawings of the U-Scan Max controller board and cables.

Document Updates

Version 10

- Removed instructions to use LOCTITE to secure the bottom screw when replacing a BANNER sensor array stick. Two nylon washers (11001719) are now used.
- Updated transfer bar adjustment gauge procedure for changes to the gauge.
- Added instructions to recalibrate the BANNER sensor array after it is adjusted by cycling the power to all BANNER adjustment procedures.
- Added instructions for adjusting the BANNER sensor array with the alignment guides.

Version 9

- Added instructions for using the auto-calibration function for the input belt scale in HyperTerminal.
- Added instructions for verifying the elevation and latitude settings for the input belt scale through HyperTerminal.
- Changed the Scaleton **Stop Bits** setting from **2** to **1** in all HyperTerminal procedures.
- Added instructions for accessing the sensor array adjustment bolts in casing with the “flip-down” cover on the faceplates.
- Updated the instructions for adjusting the vertical position of the BANNER sensor array. The sensor must detect the thicker shim (9000101).
- Added a section entitled “[Preventive Maintenance for Field Engineers](#)” on page 48.
- Added instructions for using the transfer bar adjustment gauge (page 77).
- Added instructions for using the BANNER sensor array alignment guides (page 92).

Version 8

- Added instructions for adjusting the BANNER sensor array when installed using the new brackets (page 86). This procedure applies to the newer casing “E” models shipped from the U-Scan Assembly facility as of October 2006.
- Added instructions for replacing the BANNER sensor array installed on newer casing “E” models (page 111).
- Added instructions for performing a hard zero on the input belt scale through HyperTerminal (page 62).

Version 7

- Added instructions to loosen tensioning nuts before lifting one side of the belt to prevent straining the bolts that secure the belt when they are secured after servicing.
- Added cleaning instructions for the crumb trays and collection area plate to the [U-Scan Max Hardware Basics](#) chapter.
- Added BANNER sensor array grounding information to the [U-Scan Max Hardware Basics](#) chapter.

-
- Updated BANNER sensor array cable routing diagram in the [U-Scan Max Hardware Basics](#) chapter.
 - Included part numbers in the grounding information section of the [U-Scan Max Hardware Basics](#) chapter to differentiate the short (CAB-1148) and long (CAB-1147) braided ground cables.
 - Updated instructions and illustration for adjusting the position (front-back) of the conveyor belt frames for the “E” casing in the [U-Scan Max Hardware Troubleshooting](#) chapter.
 - Updated instructions and illustration for adjusting the height of the take-away belt frame in the [U-Scan Max Hardware Troubleshooting](#) chapter.
 - Updated diagram of the load cell in the procedure “[Replacing a Belt Scale Load Cell](#)” on page 140.
 - Added a note specifying that the height of the input belt cannot be adjusted for casing version “E” and later (page 41, page 82).

Version 6

- Added adjustment overview for all sensors to the [U-Scan Max Hardware Basics](#) chapter.
- Updated diagram in the [System Overview](#) chapter to illustrate the new Scanner Scale module design.
- Updated main unit cable routing diagram in the [U-Scan Max Hardware Basics](#) chapter to include both the SCANGINEER and the BANNER sensor array cables.
- Converted bulleted list for grounding information to a table in the [U-Scan Max Hardware Basics](#) chapter.
- Moved software behavior information to a separate [Software Behavior](#) chapter.
- Added an adjustment guide to the instructions for adjusting the transfer plate.

Version 5

- Updated procedure for replacing the controller board.
- Updated procedures for adjusting and replacing the take-away belt sensor for casing versions “C” and later.
- Updated the unit dimensions in the [U-Scan Max Hardware Basics](#) chapter.
- Added the pedestal cable routing information to the [U-Scan Max Hardware Basics](#) chapter.
- Added instructions to secure three black tie-wraps to the black plastic tubing routed between the conveyor unit and the main unit after replacing a load cell. Added a drawing to the [U-Scan Max Hardware Basics](#) chapter.
- Added instructions to route 4” of plastic tubing into the pedestal and into the main unit after replacing a load cell. Added a drawing to the [U-Scan Max Hardware Basics](#) chapter.
- Added diagrams of the Scangineer sensor array cable routing (conveyor unit casing version “C” and earlier) to the [U-Scan Max Hardware Basics](#) chapter.

Version 4

- Added the **Lane Must be Clear** message information to the [System Overview](#) chapter.
- Added instructions for verifying and modifying the filter settings for the input belt scale to the [U-Scan Max Hardware Troubleshooting](#) chapter.
- Updated the grounding information in the [U-Scan Max Hardware Basics](#) chapter.
- Updated the input belt motor cable routing diagram in the [U-Scan Max Hardware Basics](#) chapter.

Version 3

- Updated the grounding information in the [U-Scan Max Hardware Basics](#) chapter.
- Updated section headings for UL compliance.

Version 2

- Updated the take-away conveyor drawing in the [Wiring Schematics](#) chapter.

Version 1

- Document creation.

Other Resources

- U-Scan Max Single Belt Site Preparation & Installation Guide (generic version) **OR** the Site Preparation & Installation Guide for the appropriate store.
- NextGen Version 2.5 Technical Reference
- U-Scan Max Single Station Generic Operator's Guide

System Overview

The U-Scan Max Single Belt is a self-checkout system designed for larger orders that enables shoppers to scan, bag and pay for their purchases without cashier assistance.

The U-Scan Max Single Belt is a regular NextGen 2.5 Station with an added single belt conveyor for moving items into the collection area. The system includes three sets of sensors and a Belt Scale under the input belt as part of the U-Scan Max security system. The major components of the Station are labeled in the diagram and described in the sections below.

U-Scan Max Single Belt Station

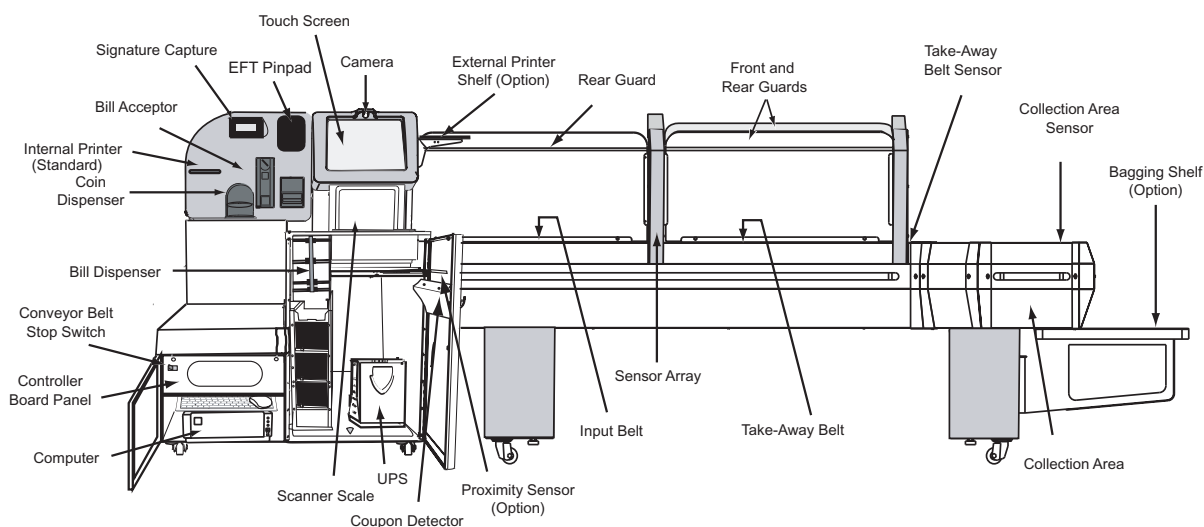

U-Scan Max Components

The components that are unique to the U-Scan Max Single Belt Station are described below.

Controller Board Panel

The controller board panel is housed above the Computer compartment and is secured with two screws. A **Power** switch is installed on the controller board panel so that the attendant can shut off the power to the sensors and motors without opening the panel.

The following are located on the controller board:

- 10 A, 3 AG Busman fuse.
- Switches that allow you to test the belts and sensors while the Computer is off.
- All cable connections for the belt devices (sensors, scales, belt motors).

-
- A power supply that connects to a separate (dedicated) AC outlet from the rest of the U-Scan Station.
 - A controller board communication cable that connects to the Edgeport.

Loosen the screws and slide the panel toward you to view the controller board.

Input Belt

The input belt is located directly beside the Scanner Scale. There is an optional front guard (Plexiglas) for the input belt that is shorter than the rear guard and curved to allow the customer to place items on the belt.

The input belt unit includes two SCALETRON load cells to weigh items and allow the U-Scan security system to verify the item's weight. The input belt advances when the weight is verified.

The maximum weight capacity for the input belt scale is 75 lbs. The recommended calibration weight is 50 lbs.

Sensor Arrays

The front and rear sensor arrays are located in the front and rear sensor pillars. When the sensor arrays detect an item, they trigger the take-away belt to advance. If the sensor array detects an item passing the sensors above the belt to be placed directly on the take-away belt, the message **Please check belts** appears at the Attendant Station to alert the attendant that the item has not been scanned.

BANNER Sensor Array

As of casing version "D," the U-Scan Max Single Station is equipped with a BANNER sensor array. The BANNER sensor array consists of a controller box and two detection sticks - an emitter stick and a sensor stick.

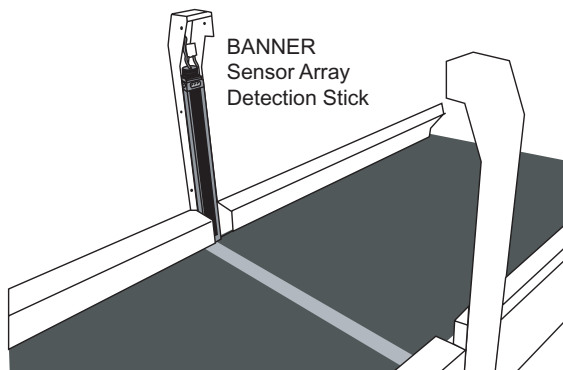

At the time of publication, the BANNER sensor array loses connection with the U-Scan software when the Customer Station software is restarted. To solve this problem, turn the power switch on the controller board off and then on again after you restart the Computer. This cycles the power for the sensor array and recalibrates it.

SCANGINEER Sensor Array

The SCANGINEER sensor array is installed in casing versions “C” and earlier. The SCANGINEER sensor array is made up of two circuit boards and an external power supply.

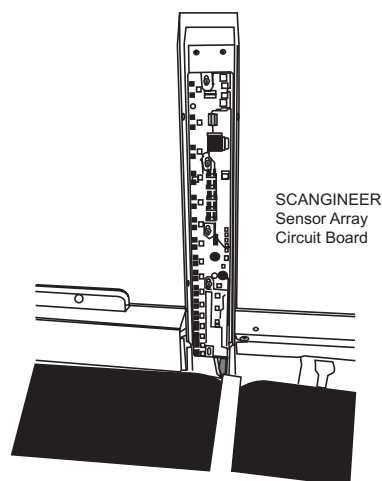

Front and Rear Guards

The front and rear guards are Plexiglas partitions that discourage customers from attempting to bypass the security system by placing items directly on the take-away belt.

Take-Away Belt

When items reach the end of the input belt, they slide onto the take-away belt. The belt stops moving when an item passes the take-away belt sensors or when the belt rotates one full cycle.

Take-Away Belt Sensor

The take-away belt sensor stops the belt when it detects an item.

Collection Area Sensor

The collection area sensor detects items that have been pushed to the end of the of the collection area. If the collection area sensor and the take-away sensor are blocked, the system prompts the customer and attendant to start bagging items. This helps prevent items from becoming damaged.

Software Behavior

NOTE: *This section only describes behavior that is unique to or specially customized for the U-Scan Max Single Belt.*

Maintenance Mode Belt Maintenance

A **Belt Maintenance** button displays on the main **Maintenance Mode** screen on the U-Scan Max system. On the **Belt Maintenance** screen, the attendant can stop or start the input and take-away belts for cleaning or maintenance purposes.



U-Scan Max Single Belt Security

Security System Components

The security system for the U-Scan Max Single Belt Station is made up of the same components that provide security at a regular U-Scan Station and the following additional components:

- Input Belt Scale
- Sensor arrays
- Take-away belt sensor
- Collection area sensor

For a more detailed description of how the U-Scan Max Single Belt system security functions, refer to [“Security Process”](#) on page 15.

U-Scan Max Messages

The following messages are unique to the U-Scan Max:

- [“Check Belts” Message](#) (page 10)
- [“Lane Must be Clear” Message](#) (page 12)
- [“Lane Full, Please Help Bag Items” Message](#) (page 12)
- [“Lane Idle, Order Not Tendered” Message](#) (page 13)

These messages (or a shortened version) also appear on the Mobile Attendant iPad, if applicable.

“Check Belts” Message

This message is unique to U-Scan Max systems. It appears in the security message area when the sensor arrays detect that an unscanned item has passed the sensor and was placed directly on the take-away belt. In addition, this message appears when the user places weight on the input belt while it is already in motion. If this message appears in this instance, it indicates that an item has passed through the weight-based security system that should not have.

Touch the rotating siren to clear this message. One or both of the belts may move after the attendant overrides this violation. The take-away belt always moves after the attendant overrides this violation, unless the lane is full.

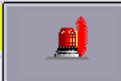
Lane 21 connected					
1	GM TRIX CEREAL		F	2.59	
2	GM TRIX CEREAL		F	2.59	
3	PREM YELLOW BANANAS				
	1.22 Lbs @ 1/	0.39	F	0.48	
Enter Item to be sold.		Please Check Belts			

Customization - Weight and Sensor Array (Arch) Violations:

Stores can opt to show weight and arch violations in the order in which they occur, or to always give priority to arch violations.

If the store chooses to **show weight and arch violations in the order in which they appear** (default behavior), the following behavior occurs:

- If an arch violation occurs while there is an unresolved weight violation, the arch violation will not display until the weight violation is either corrected or overridden.
- If a weight violation occurs while there is an unresolved arch violation, the weight violation will not display until the attendant overrides the arch violation. (If the weight violation is corrected while the arch violation is displayed, the weight violation message does not display.)

If the store chooses to **give priority to arch violations**, the following behavior occurs:

- If a weight violation occurs while there is an unresolved arch violation, the weight violation message will not display until the attendant overrides the arch violation.
- If an arch violation occurs while there is an unresolved weight violation, the arch violation message displays immediately in the security message area. The weight violation will display again after the attendant overrides the arch violation.

“Lane Must be Clear” Message

This message appears when a customer tries to start an order at the Station while the collection area sensor is blocked.

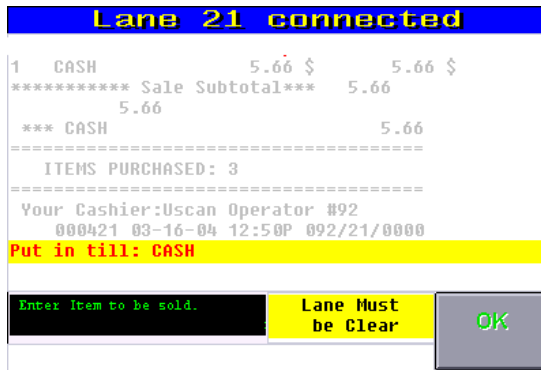

The screen below displays at the Customer Station to inform the customer that the items from the bagging area must be removed before a new order can begin.

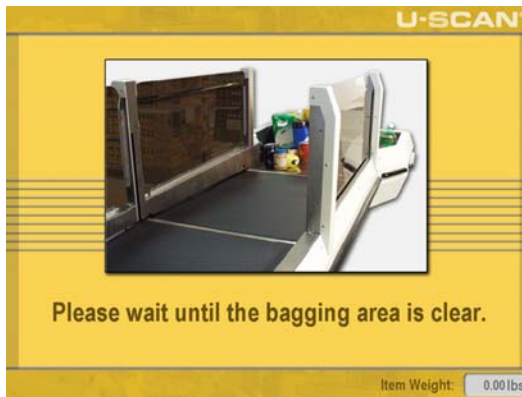

When the collection area sensor becomes free, the message is cleared and the take-away belt moves to move any items on the take-away belt into the collection area.

“Lane Full, Please Help Bag Items” Message

This message appears when the take-away belt **and** collection area sensors are blocked and informs the attendant that the customer may require assistance in bagging items. This

functionality prevents items from becoming squished in the collection area. The customer is also alerted when the **Please Bag Items** screen displays.

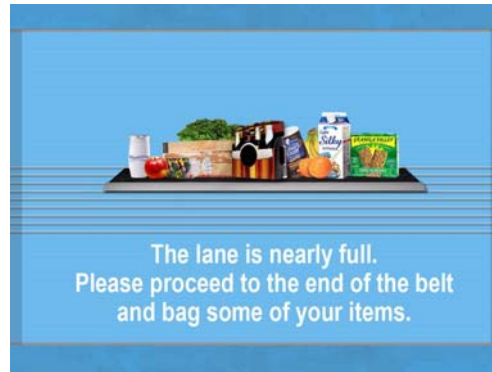

When the **Please Bag Items** screen displays, the take-away belt will move 1/2 of a revolution of the belt to attempt to clear the items from the take-away belt. If the sensors do not become clear, customers can continue scanning a set number of items (default = 4 items) before the **Lane Full** screen displays and the Scanner Scale will no longer accept items. The take-away belt will only advance items into the collection area again once the collection area sensor becomes free.

Customization

- The number of items that the customer can scan after the **Please Bag Item** screen displays can be changed.
- Stores can choose to configure this option so that the customer is never prevented from scanning more items. In this instance, the **Please Bag Items** screen will appear, but the customer is not restricted in the number of items that can be scanned.

“Lane Idle, Order Not Tendered” Message

This message appears when an order is in progress and there has been no action (items scanned, buttons selected, weight violations) at the Station or the collection area sensors have not detected any items in the bagging area for 20 seconds (default). The message **does not prevent the customer from continuing the order** and serves only to inform the attendant that the customer may need assistance. When any type of action is performed on the lane (i.e. an item is scanned, the customer selects a button, etc.), the message will be

cleared. The attendant can select the lane window at any time to clear the prompt, but it is not necessary.

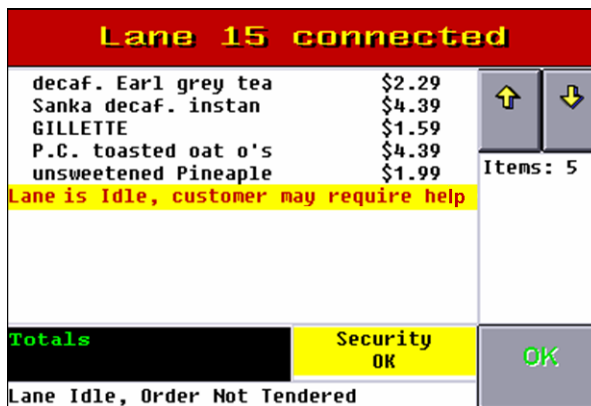

Customization

The **Lane Idle, Order Not Tendered** message can be customized according to your store's needs:

- This message can be disabled completely.
- The idle time (default 20 seconds) can be increased or decreased.
- The system can be configured so that this message **only** displays when there are no items blocking the sensors in the collection area. This prompt then notifies the attendant that a customer has removed items from the end of the belt.
- The system can be configured so that this message **only** displays when the lane is in Payment mode. In this instance, the attendant is notified that the customer may require assistance in completing the payment.

Security Process

The following flowchart illustrates the U-Scan Max Single Belt Station security process.

U-Scan Max Single Belt Security Process

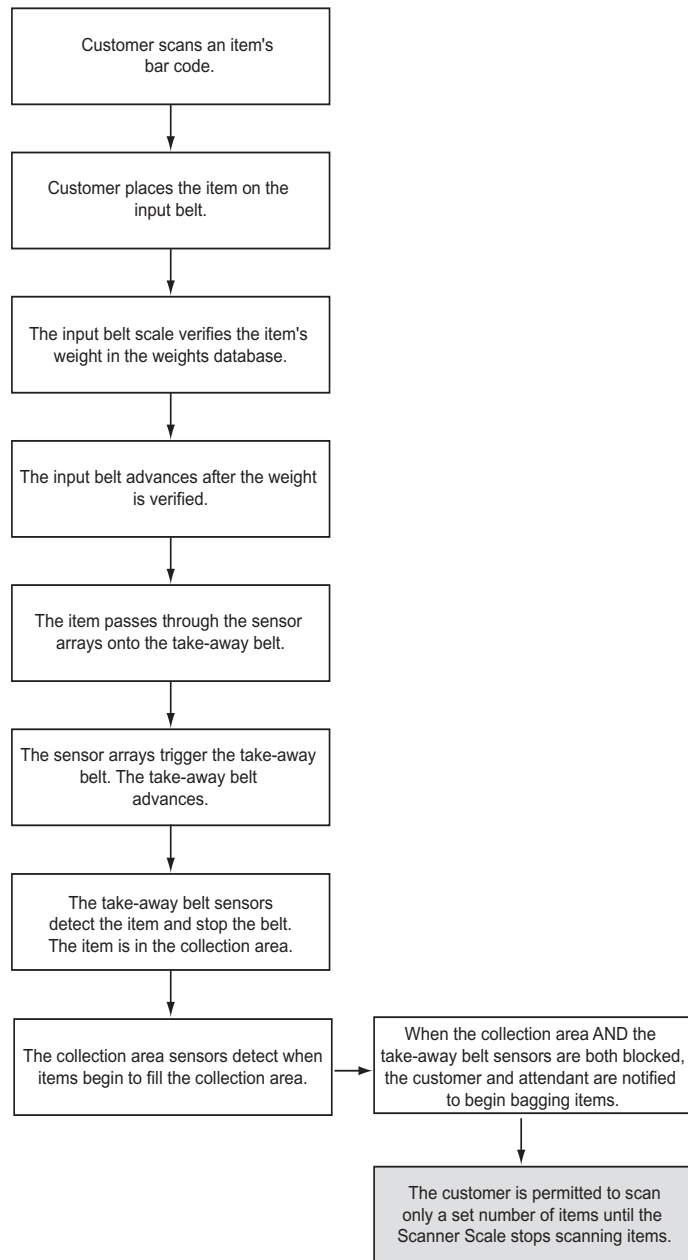

 = Optional

Sensor Array Violation

The flowchart below illustrates the behavior when a sensor array (arch) violation occurs.

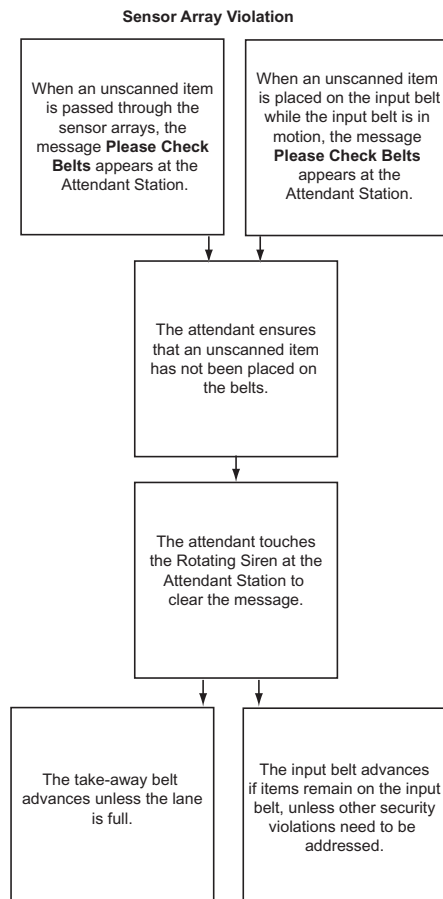

Light Items Handling

An item is identified in the weights database as a light item if it weighs less than 0.05 lb. When a light item is scanned and placed on the belt, the weight is not significant enough to trigger the input belt. If a light item is scanned, the input belt automatically begins to move approximately **6 seconds after the item is scanned**. (Stores can configure this time period.) Light items do not need to be detected by the sensor array (arches). After the input belt has run a full rotation, the diverter belt and appropriate take-away belt advance.

NOTE: *If another item is scanned at any point during this process, the regular order flow described in “Security Process” on page 15 starts.*

New Items Handling

An item is considered a new item if it does not yet have a record in the weights database. When a new item is scanned, the customer is prompted to place the item on the Scanner Scale. If the item weighs more than 0.05 lb., a weight record is created.

NOTE: *Stores can opt to disable this option in U-Scan Max Single Belt Stations. In this instance, a weight record will not be created for the new item.*

If a new item is scanned and less than 0.05 lb. is placed on the Scanner Scale, the item will be registered as a light item. The system will wait for a significant weight (greater than 0.05 lb.) for **15 seconds** before the light item record is created and the customer is prompted to place the item on the belt. The system then follows the process outlined above to move the item to the end of the unit.

If double-handed scanning is available, a customer can choose to handle new items in one of several ways:

- Customers are able to scan more than one new item before security needs to be resolved (the items placed on the belt).
- Customers can only scan one new item before security needs to be resolved. Customers cannot double-scan if one of the items is new. **Default behavior.**
- Customers can scan new items only when all regular items (non-new) have been processed by security and have left the belt. Customers can scan a regular item immediately after new item.

Optional Software Features

Double-Handed Scanning

The U-Scan Max software includes support for double-handed scanning. This means that a customer can scan two items and place them both on the belt at the same time or in quick succession. The U-Scan security system is able to calculate the total weight that should be added for both items. This feature allows the customer to process an order quicker as compared to repeatedly scanning a single item and placing it on the belt.

Attendant Mode Behavior for the U-Scan Max Single Belt Station

NOTES: *Not all stores have **Attendant Mode** functionality.*

*For standard **Attendant Mode** behavior in regular (non-belted) U-Scan systems, refer to the **Attendant Functionality at the Customer Station** document.*

Attendant Mode (Local Direct Mode) is not accessible while the **Waiting for an Available Lane** screen is displayed at the Customer Station. If the attendant scans the control bar code, **Attendant Mode** is not accessed.

If a security violation that requires an attendant override occurs, the **Override** button (flashing triangle) displays on the Customer interface when the attendant scans the control bar code at the Customer Station. When the attendant touches the **Override** button, the violation is resolved and the belt moves.

If the attendant purchases or voids an item in **Attendant Mode**, the belt will move when something is placed on the belt. Weight security is disabled for items purchased in **Attendant Mode**.

If the attendant purchases items in **Attendant Mode** and both the collection area and take-away sensors become blocked, the **Start bagging items** screen displays for several seconds before the **Attendant Mode** screen displays again. The attendant can continue purchasing items until the belt becomes full. When the belt is full, the **Lane Full** screen displays and the **Attendant Mode** screen will not display again until the sensors are cleared. At this point, the belt also begins to move.

U-Scan Max Hardware Basics

This chapter presents the following information:

- [U-Scan Max Single Belt Dimensions](#) (page 20)
- [U-Scan Max Single Belt Devices](#) (page 21)
- [Casing](#) (page 22)
- [Grounding](#) (page 23)
- [Cables](#) (page 26)

U-Scan Max Single Belt Dimensions

Full Width = 40"
Height = 52" (with wheels)
Length = 137"

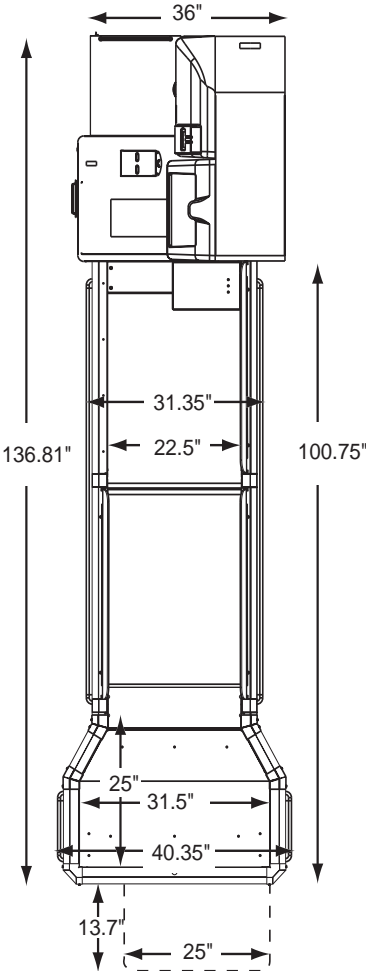

Service Clearance

The following service clearance is required for the U-Scan Max Station:

- At least 12" behind the unit. 18" is preferable.
- At least 3' in front of the unit to allow the field engineer to move the conveyor unit for servicing.

U-Scan Max Single Belt Devices

The following diagram will help you locate the main U-Scan Max devices.

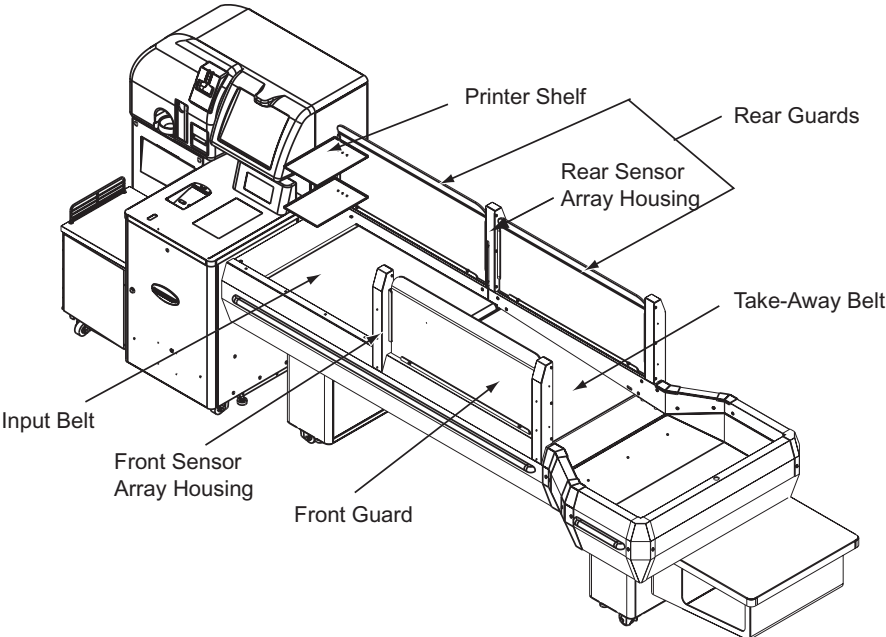

Casing

The U-Scan Max Single Belt separates into two modules:

- Conveyor unit
- Main (U-Scan) unit

When the U-Scan Max Single Belt Station is installed in the store, the two modules do not need to be separated for servicing after the initial installation.

During the initial installation, the two units are joined by two screws that are fastened from the inside of the main unit into threaded holes on the guard plate on the front of the conveyor unit.

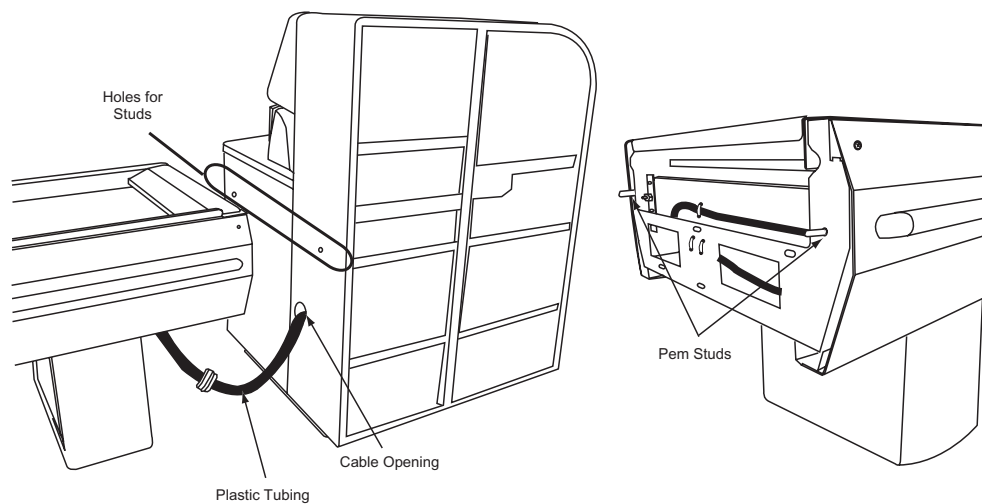

For detailed instructions, refer to the **U-Scan Max Single-Belt Station Site Preparation and Installation Guide**.

Grounding

The U-Scan Max Single Belt Station is grounded in the following places:

From	To	Cable Type
Controller board terminal block	Ground stud on controller board tray	Green and yellow twisted cable
Ground stud on controller board	Unpainted pem stud on the casing behind the controller board	Braided ground cable
Screw on the back of the UPS	Unpainted pem stud on the casing behind the controller board	Braided ground cable
Take-away belt motor	Self-tapping screw in the bottom of the conveyor unit frame in front of the collection area	Green and yellow twisted cable with ring-type bare crimp lug termination
Input belt motor	Self-tapping screw in the bottom of the conveyor unit frame in front of the input belt	Green and yellow twisted cable with ring-type bare crimp lug termination
Input belt motor grounding point	Take-away belt motor grounding point	Braided ground cable (CAB-1148 - shorter cable)
Unpainted in the main unit behind the controller board	Input belt motor grounding point	Braided ground cable (CAB-1147 - longer cable)
BANNER sensor array cable	Self-tapping screw on side of sensor arm base	Green and yellow twisted cable with wire lug termination

Controller Board Grounding

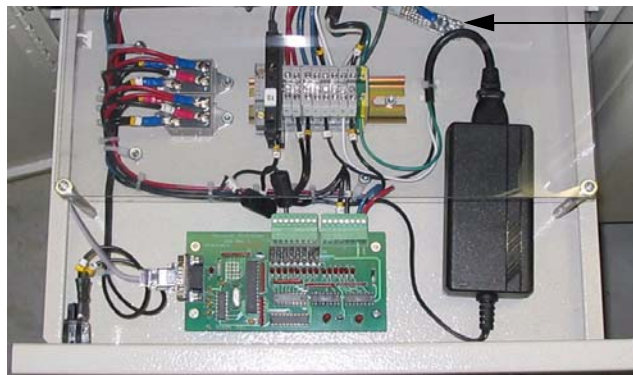

Main Unit Grounding

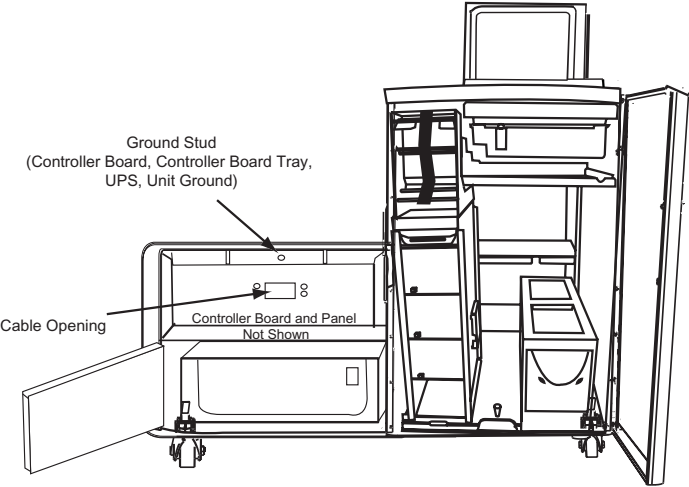

Conveyor Unit Grounding

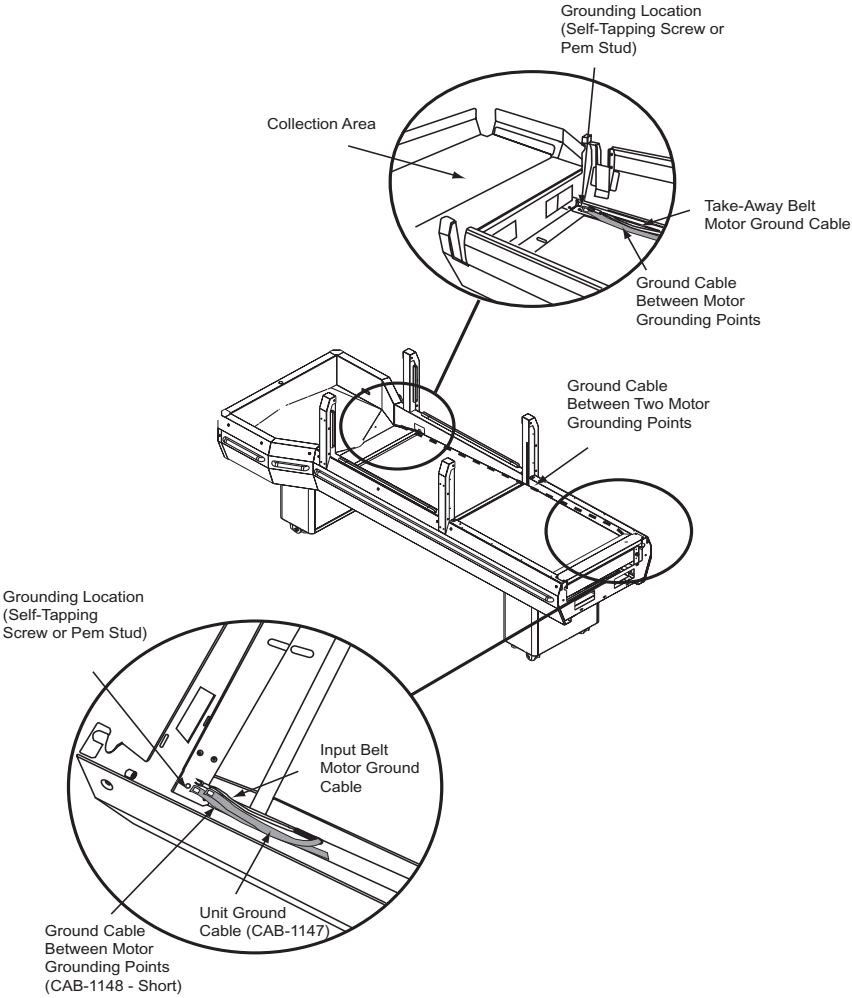

BANNER Sensor Array Grounding

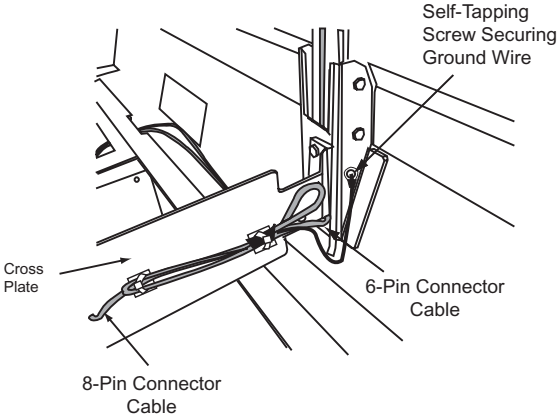

Cables

Cable Assignments

The conveyor unit cables are labeled on the connector head. The table below lists the conveyor unit cable assignments.

Component	Connector Label
Input belt motor	V
Take-away belt motor	W
SCANGINEER sensor array power supply (Casing version “C” and earlier)	X
Take-away sensor	Y
Collection area sensor	Z
Cable harness (connection to controller board)	BC
BANNER sensor array to controller board	P1
BANNER sensor array to controller box	P2
BANNER sensor array to controller box (DB-9)	P3
BANNER sensor array to sensor stick	P5
BANNER sensor array to emitter stick	P6

NOTE: *The SCANGINEER sensor array communication cable and transmit-receive cable and the SCALETRON load cell cables are not labeled.*

Cable Connections

Cable Harness

Cables V, W, Y, and Z are grouped into a cable harness from the controller board. The wire harness has a separate connector head for each cable that connects to the device cable. The controller board cable end of this cable is labeled “BC.” It connects to cable “BC” from the controller board.

Controller Board

The power and communication for all of the belted devices **except the SCANGINEER sensor array** (casing version “C” and earlier) is supplied through the controller board.

The controller board power cable must be connected to a dedicated AC wall socket. **NEVER** connect the controller board power cable to the UPS.

The controller board communication cable connects to Port 9 (COM11) on the Edgeport.

BANNER Sensor Array (Casing Version “D” and Later)

The BANNER sensor array power is provided through a 2-pin cable from the U-Scan Max Single Station controller board.

The communication is handled through a controller box. A null modem (DB-9 to DB-25) communication cable (CAB-1093) connects to the controller box and to port 14 on the underside of the Edgeport.

The emitter and sensor sticks are connected to the sensor array controller box and to the controller board by a cable assembly (11000534). The cable assembly and controller box connections are shown below:

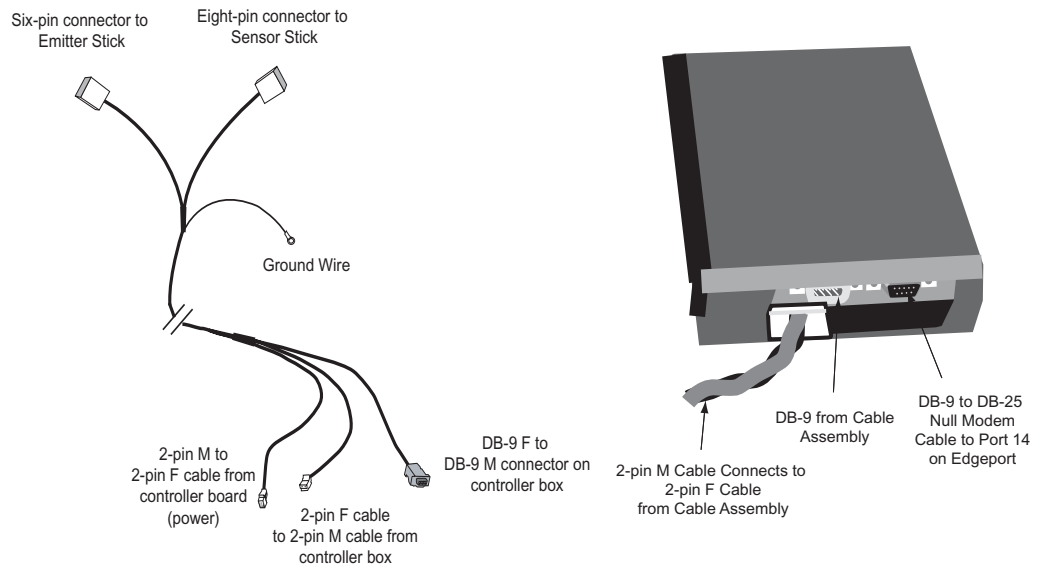

SCANGINEER Sensor Array (Casing Version “C” and Earlier)

The sensor array has its own power supply adapter (cable “X”) that is connected to the power bar.

An RS-232 communication cable connects directly to port 14 of the Edgeport (via a DB-9 to DB-25 adapter). Port 14 of the Edgeport is located on the underside of the Edgeport.

A transmit-receive cable connects the Transmitter and Receiver circuit boards.

Cable Routing

The cables will already be routed inside the unit. If you need to remove a cable to replace a component, **note the original cable routing** and follow it when you reroute the cable. The diagrams below provide an overview of the major cable routing. **Subject to change.**

Main Unit Cables - Overview

NOTE: *This diagram contains the cable routing for both the SCANGINEER and the BANNER sensor arrays. Only one sensor array type will be installed on your system.*

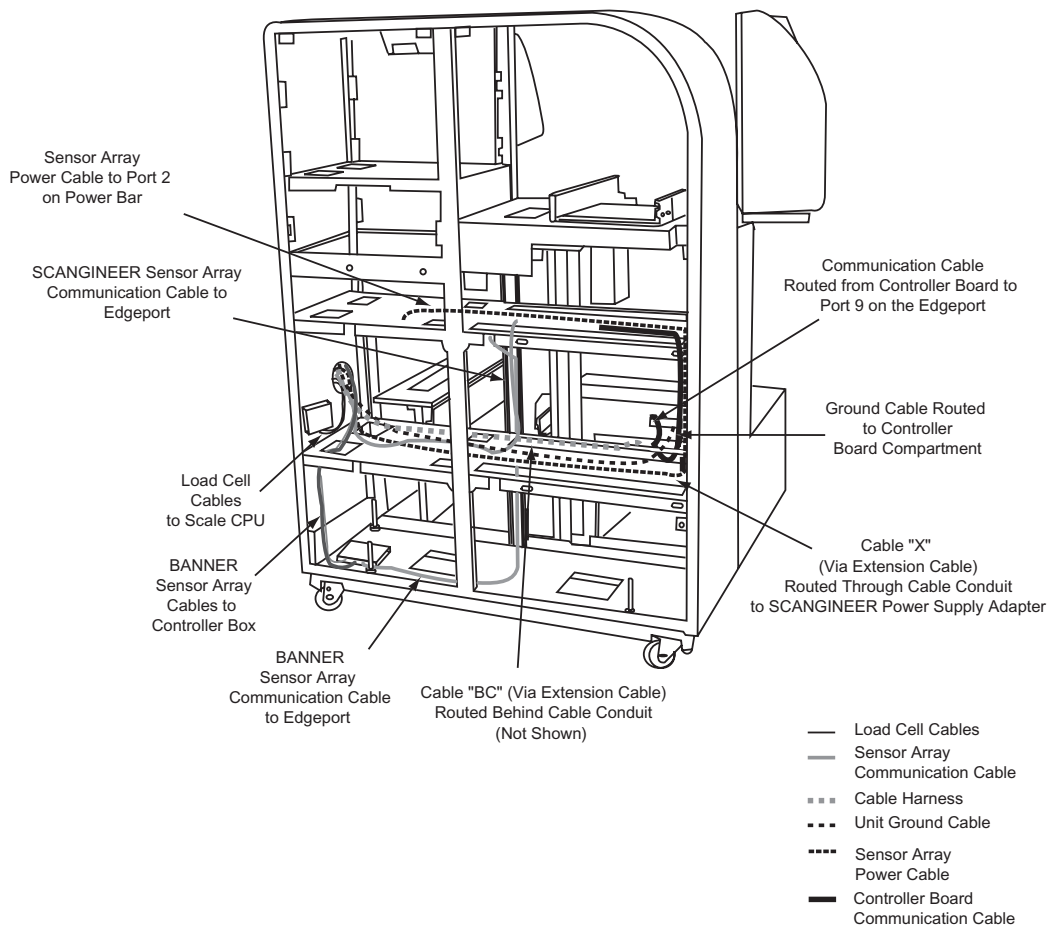

Conveyor Module Cables - Overview

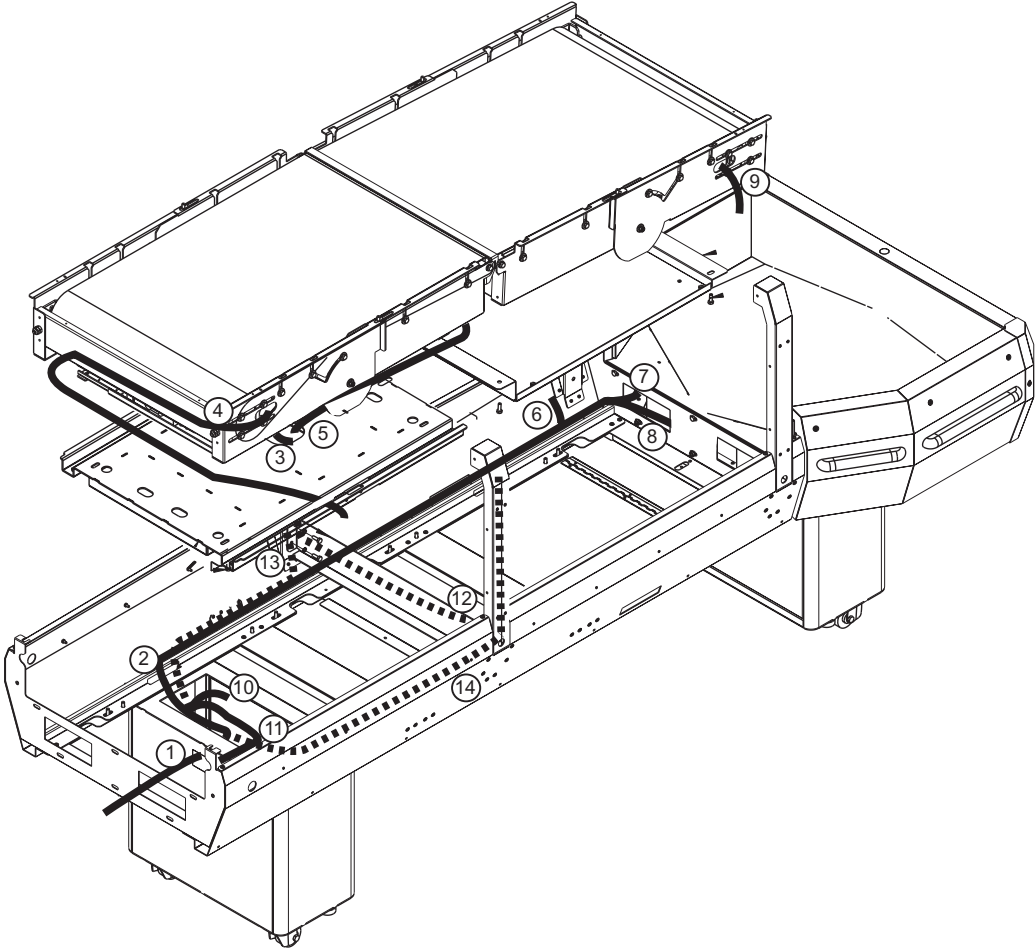

Refer to the table below for a description of the major cable routing in the conveyor unit.

Label in Diagram	Cable(s)	Path
1	<ul style="list-style-type: none"> • Cable harness from controller board • Load cell cables • Unit ground cable <p>Casing version “D” and Later:</p> <ul style="list-style-type: none"> • BANNER sensor array cable assembly <p>Casing version “C” and Earlier:</p> <ul style="list-style-type: none"> • SCANGINEER Sensor array communication cable • Sensor array power cable 	<p>From the main unit through the cable opening on the front pedestal and into the pedestal.</p> <p>For more information, refer to “Cables Inside the Pedestal” on page 34.</p>
2	Cable harness	<p>From the pedestal up into the side channel.</p> <p>Through the side channel to the end of the conveyor unit.</p>
3	Front load cell cable	<p>Across the bottom plate and through the square opening on the bottom plate and into the pedestal.</p>
4	Input belt motor cable	<p>Through the cable hole on the side of the belt frame and around to the front of the belt frame.</p> <p>Looped along the belt frame and conveyor frame as shown in “Input Belt Motor Cable” on page 33.</p> <p>Back into the side channel and into the pedestal.</p>
5	Rear load cell cable	<p>Across the bottom plate and through the square opening on the bottom plate and into the pedestal.</p>
6	<p>Take-away belt sensor cable (Connector “Y” from the cable harness)</p>	<p>From the cable harness up toward the take-away belt sensor installation point.</p>
7	<p>Collection area sensor cable (Connector “Z” from the cable harness)</p>	<p>Through the cable opening and into the side channel of the collection area to the sensor installation point.</p>
8	<p>Take-away belt motor cable (Connector “W” from the cable harness)</p>	<p>From the cable harness and through the rear cable opening into the collection area.</p> <p>Cable slack is left in collection area.</p>

Label in Diagram	Cable(s)	Path
9	Take-away belt motor cable	Through the cable opening on the belt frame and into the side channel to connector “W” from the cable harness.
10	Input belt motor cable (Connector “V” from the cable harness)	Connects to connector “V” from the input belt motor inside the front pedestal.
11	<ul style="list-style-type: none"> Input belt motor ground cable (Extended from input belt motor cable) Unit ground cable 	<p>Up through opening on the pedestal and straight along the belt frame to the grounding point.</p> <p>For more information, refer to “Conveyor Unit Grounding” on page 24.</p>
12	<p>Casing Version “C” and Earlier Only:</p> <ul style="list-style-type: none"> Sensor array transmit/receive cable 	Between the sensor pillars (transmit and receive circuit boards).
13	<p>Casing Version “D” and Later:</p> <ul style="list-style-type: none"> 6-pin cable from the BANNER sensor array cable assembly <p>Casing Version “C” and Earlier:</p> <ul style="list-style-type: none"> Sensor array communication cable Sensor array power supply (cable “X”) 	<p>Casing Version “D” and Later:</p> <p>Beside the cable harness to the emitter stick.</p> <p>Casing Version “C” and Earlier:</p> <p>Beside the cable harness to the receiver circuit board.</p> <p>Slack is set into bottom of sensor pillar.</p>
14	<p>Casing Version “D” and Later Only:</p> <ul style="list-style-type: none"> 8-pin cable from the BANNER sensor array cable assembly 	<p>Casing Version “D” and Later:</p> <p>Through the center channel to the sensor stick.</p>

Cable Routing Between the Modules

All of the belted module cables are routed into the pedestal and placed inside a 3' length of SUPERFLEX V-slit plastic tubing, then routed into the main unit as shown below. The three black tie-wraps on the plastic tubing **MUST** be present as per UL requirements.

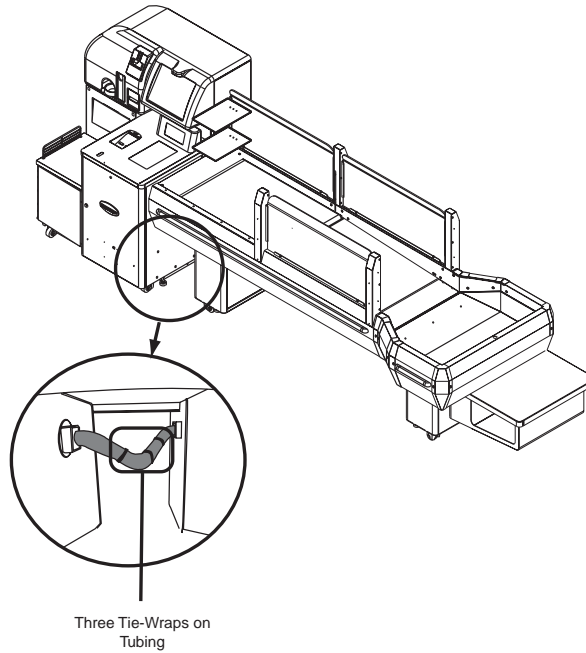

A CAB-TITE cable gland is installed in the entry point into the main unit and in the exit point from the conveyor unit. Approximately 4" of tubing must be routed into the pedestal and into the casing.

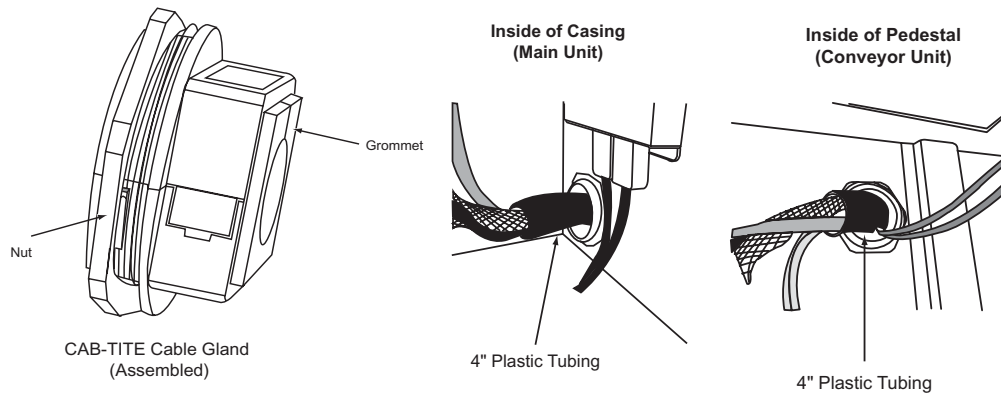

BANNER Sensor Array Cables

The BANNER detection sticks are installed in casing version “D” and later.

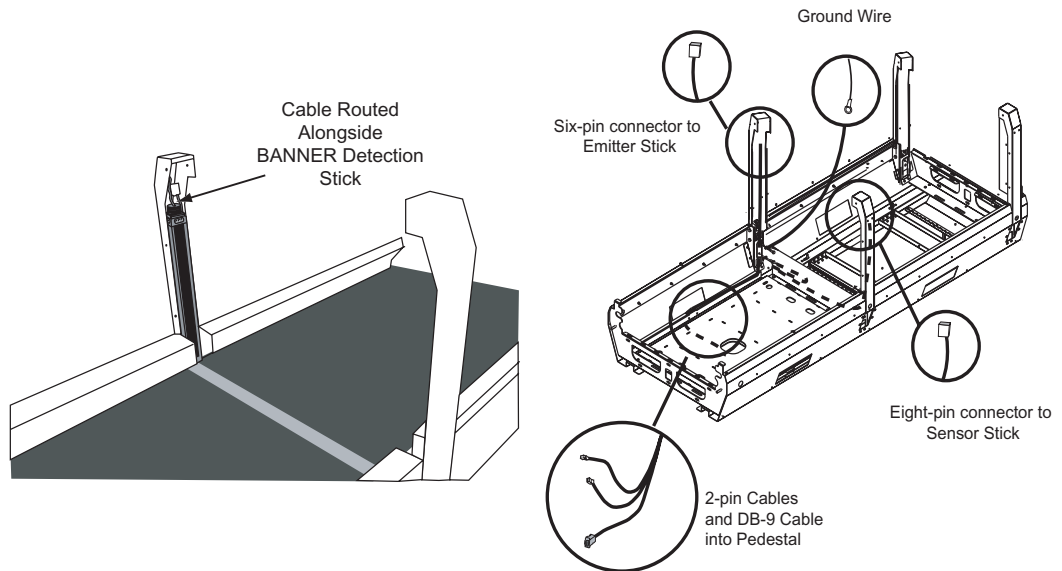

SCANGINEER Sensor Array Cables

The SCANGINEER circuit boards are installed on conveyor unit casing versions “C” and earlier.

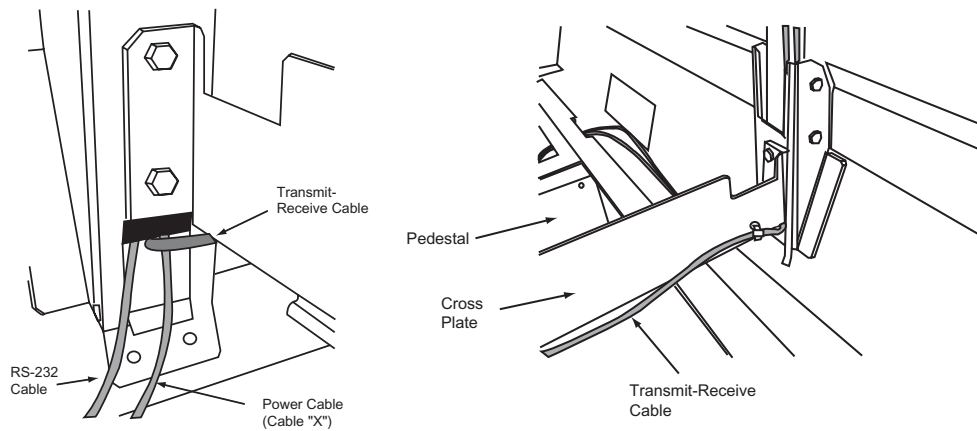

Input Belt Motor Cable

The input belt motor cable must be routed in a loop at the front of the conveyor unit to prevent it from interfering the scale. The loop on the cable **cannot** touch the belt frame.

The cable must be slightly twisted as it is routed so that the loop does not touch the belt frame.

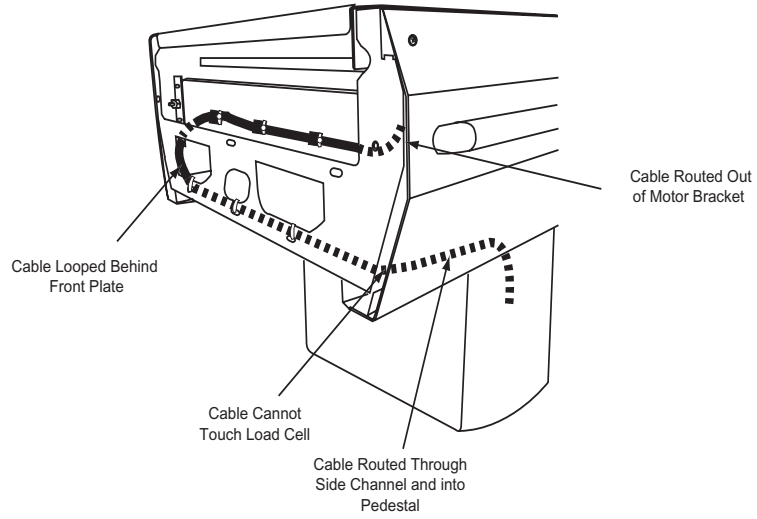

Cables Inside the Pedestal

The cables inside the pedestal are routed as shown below.

Casings with the BANNER Sensor Array

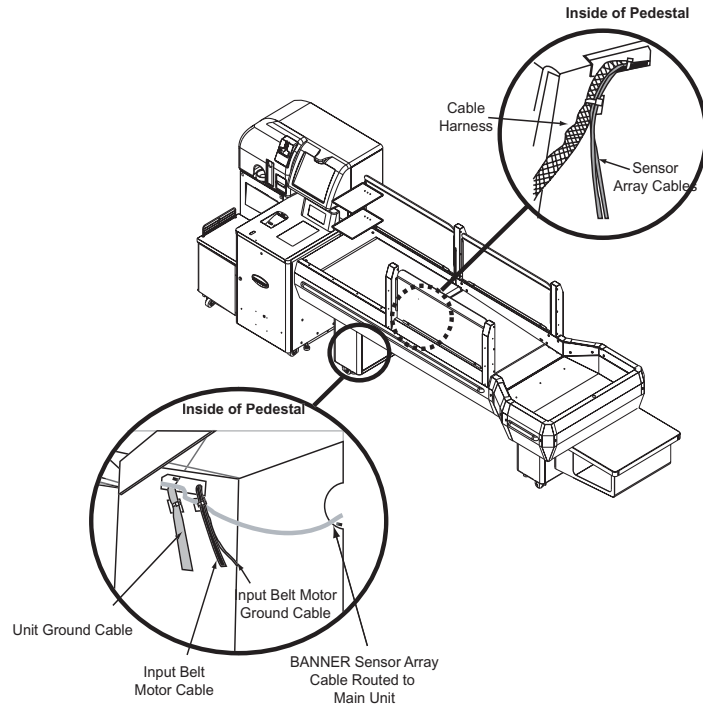

Casings with the SCANGINEER Sensor Array

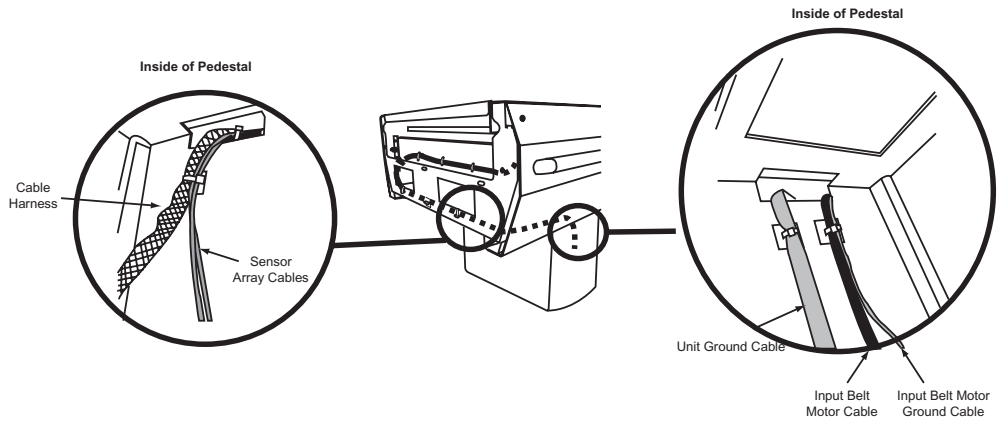

Communication Cable Assignments

The diagram below represents the U-Scan Max Single Belt Station device cabling connections.

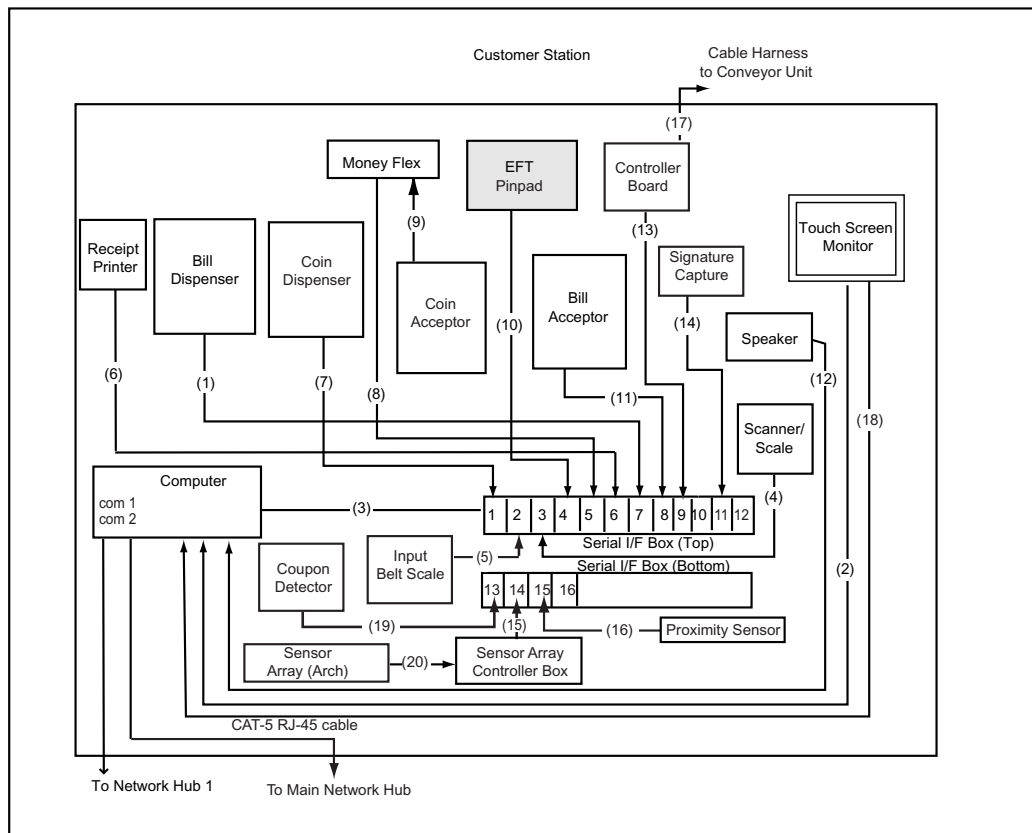

Power Bar Assignments

The diagram below demonstrates the power bar assignments in a *standard* North American U-Scan Max Single Belt Station.

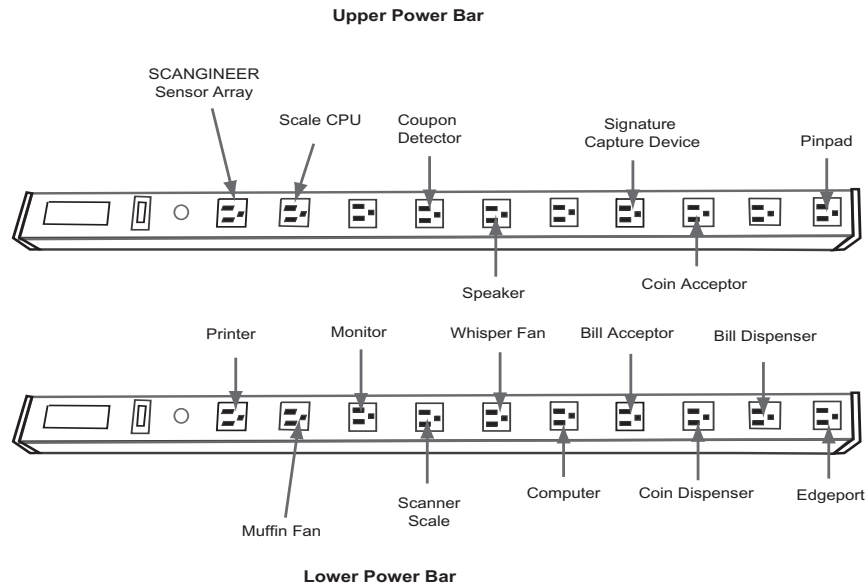

*The Proximity Sensor connects directly to the UPS.

NOTE: *The SCANGINEER sensor array power supply applies to casing version "C" and earlier. The BANNER sensor array installed in casing version "D" and later is powered through the controller board and does not have an external power supply.*

U-Scan Max Maintenance

This chapter presents the following information:

- [End-User \(Attendant\) Maintenance](#) (page 38)
- [Field Maintenance and Service Overview](#) (page 41)
- [Preventive Maintenance for Field Engineers](#) (page 48)

End-User (Attendant) Maintenance

Cleaning the U-Scan Max

Cleaning Solution

Mix one part glass cleaner and one part water.

Daily Cleaning

Clean the following U-Scan Max components on a daily basis:

- Sensor reflector plates (opposite the sensors)
- All conveyor belts
- Crumb trays

To clean the conveyor belts,

1. Access **Maintenance Mode**.
2. Touch **Belt Maintenance**.



3. Touch the **Start** button beside the belt you wish to clean.



4. Spray the cleaning solution onto a cloth or paper towel.

-
5. Gently rub the belt with the cloth or towel as it runs to clean the belt.

To clean the crumb trays:

Two hinged crumb trays are located on the underside of the conveyor unit. Magnets fasten the crumb trays in place.

1. Locate the two crumb trays on the underside of the conveyor unit.

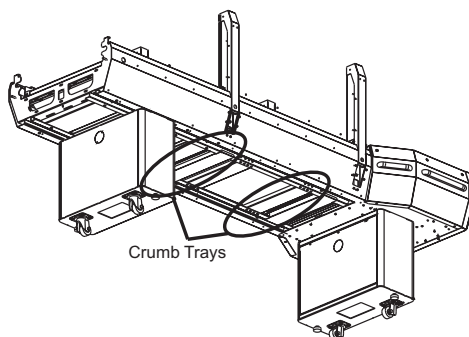

2. Pull down on the crumb tray to open it.
3. Wipe the crumb tray with the recommended cleaning solution.
4. If necessary, sweep under the unit.

Other Cleaning

Clean the following components on an as-needed basis:

- Collection area plate
- End-access plate (only to clean liquid spills)

To clean the collection area plate:

A metal plate fits in to the collection area to direct items towards the back of the unit.

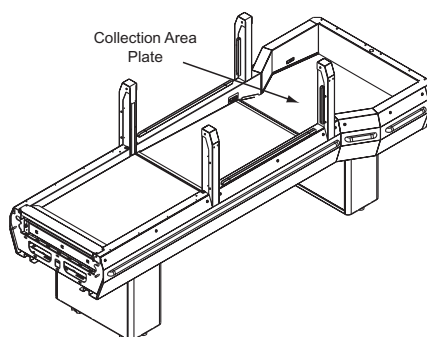

1. Lift the collection area plate out to clean any liquid spills.
2. Clean the top side and the underside of the plate with the suggested cleaning solution.
3. When it is dry, replace the collection area plate.

To clean the end-access plate:



CAUTION:

Stop the U-Scan software before you remove the end-access tray, because the belts can start moving if the sensor becomes blocked.

Only remove the end-access plate for cleaning if liquid is spilled on the plate. Lower the crumb tray on the underside of the unit to remove any other debris that has fallen under the plate.

1. Shut down the U-Scan Station from **Maintenance Mode**. Refer to your **Operator's Guide** for instructions.
2. Lift and remove the end-access plate.

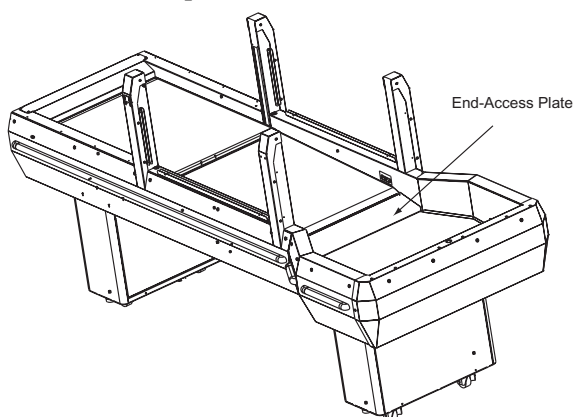

3. Use a cloth dampened with the suggested cleaning solution to wipe both sides of the plate.
4. Replace the plate as described below.

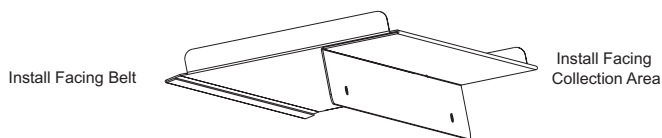

Field Maintenance and Service Overview

Conveyor Belts

Belt Component Replacement

The input and take-away belts are both equipped with a pivoting belt frame that allows the field engineer to replace all of the belt components (motor, idler, belt, scale load cells on the input belt) without having to separate the unit or remove the belt frame. The belt frame itself should never need to be replaced.

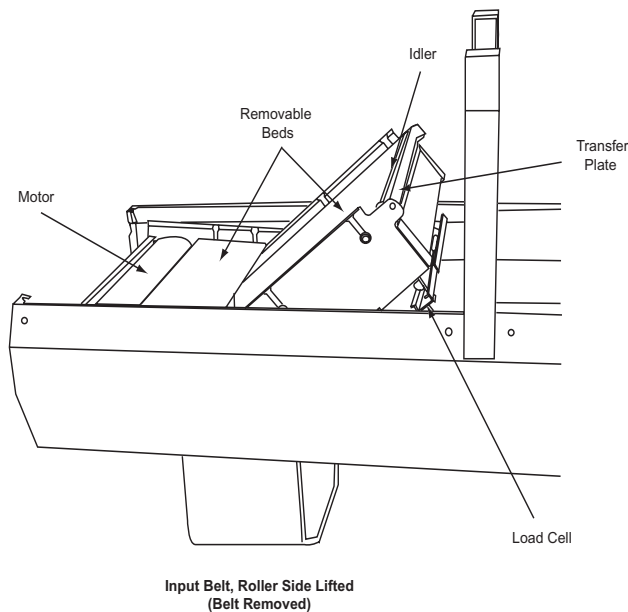

If you need to lift one side of the belt, it is important to loosen the belt tension adjustment nuts before lifting the belt. If you secure the belt in the operating position after servicing while the belt is fully tensioned, it puts strain on the bolts securing the belt frame.

Loosen the nuts before lifting the belt, then adjust the belt tension after you secure the belt in the operating position.

Field engineers access the belt frame to replace a belt component by removing the front and rear guards (Plexiglas), sensor faceplates, and internal skirts.

Belt Position

The take-away belt height and position within the conveyor unit (front-back) can be adjusted with bolts located on the underside of the casing.

The height of the input belt in casing version “E” and later cannot be adjusted. However, the studs on the load cells are installed in rectangular slots to allow field engineers to adjust the front-back position within the conveyor unit.

In casing version “D” and earlier, both the height and position of the input belt are adjustable.

Belt Tension and Tracking

The field engineer has access to the nuts that control the belt tension and tracking when the front guard plate (input belt) or end-access plate (take-away belt) is removed.

Guide to Gauging the Conveyor Belt Tension

If there is not enough tension in the conveyor belt, one of the following situations can occur:

- Greater weight fluctuations will occur
- The belt “bubbles up” when it runs.
- The belt stops if pressure is applied to it, but the motor continues turning.
- The belt stops when an item is placed on it, but the motor continues turning.
- The input belt motor begins to turn before the belt starts to advance.

NOTE: *Tension is extremely important for the input belt. The take-away belt can still function if it is slightly too loose.*

If there is too much tension in the conveyor belt:

- A squealing noise will start when the belt starts. This is the sound of the bearings on the rollers.

Transfer Bar

Two adjustment screws on the underside of the transfer bar between the input and take-away belts allow field engineers to adjust the angle of the bar and the gap between the bar and the take-away belt.

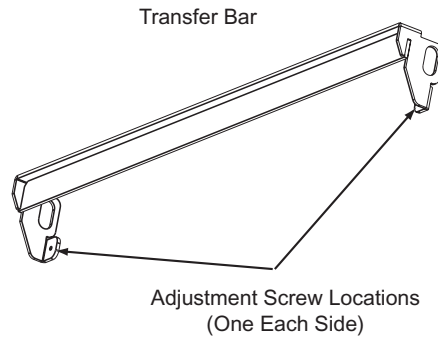

The transfer bar between the input and take-away belts must be adjusted as follows:

- Adjust the transfer bar so that it **slopes down 3-5°** towards the take-away belt.
- Adjust the transfer bar so that the **gap** between the bar and take-away belt is 0.090 - 0.12" (**3/32 - 1/8"**).

If available, use the **transfer bar adjustment gauge** to align the transfer bar properly.

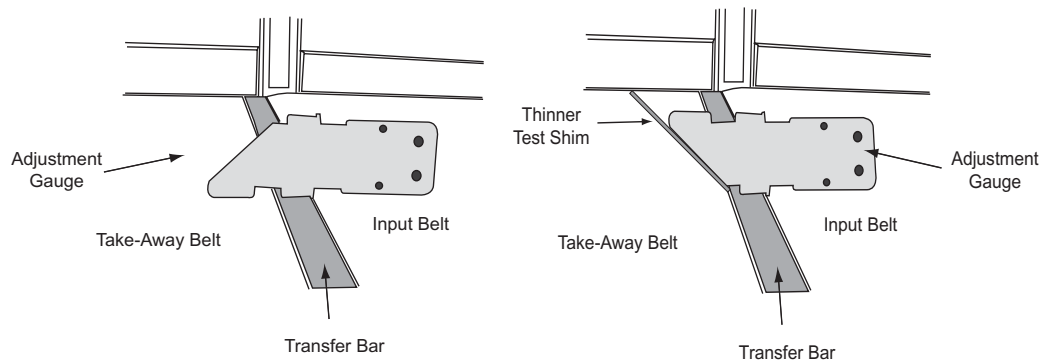

For more detailed instructions on adjusting the transfer bar, refer to [“Adjusting the Transfer Bar Height”](#) on page 77

Sensor Array

The BANNER sensor array consists of a sensor and an emitter detection stick.

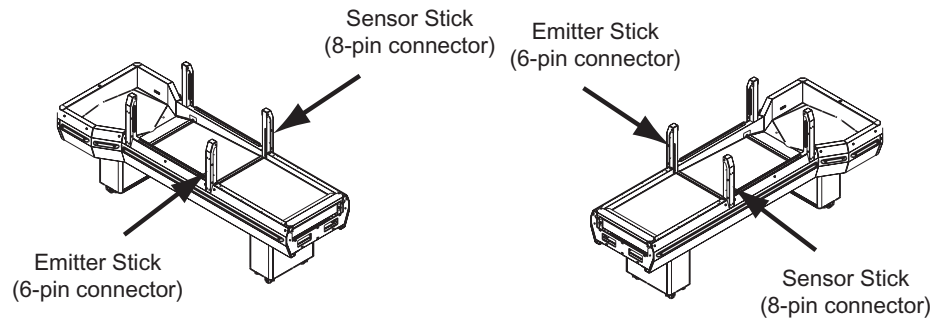

Colored LEDs indicate the status of the sensor array. Refer to the table below for LED indications.

Detection Stick	LED	Function
Emitter	Red	Power on, operation OK
Sensor	Red	Object detected
Sensor	Yellow	<ul style="list-style-type: none">• Sensor not properly aligned• Lens may be dirty• Device may be faulty
Sensor	Green	Alignment of sensor is correct, ready for operation

BANNER Sensor Array (Casing Version “D” and Later)

Current Casing Models

In later casing “E” models, a dual bracket assembly allows field engineers to adjust the height, tilt, and beam direction of the sensor array. When field engineers need to perform minor adjustments to the sensor array, a “flip-down” cover secured with a single screw provides easy access to the adjustment mechanisms.

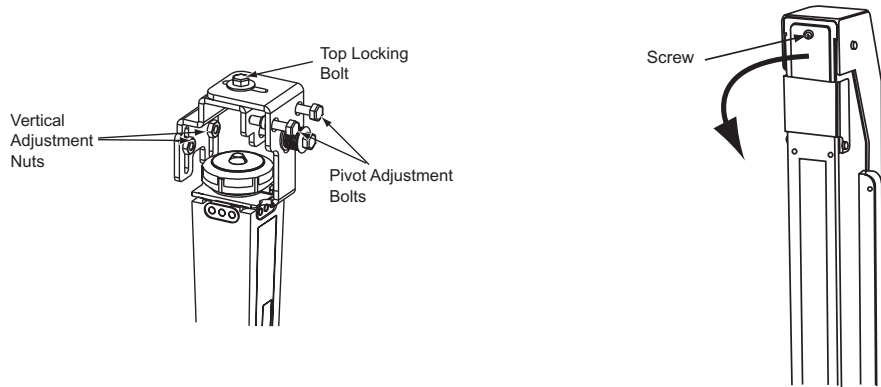

The following tools and gauges are also available to field engineers for sensor array adjustments:

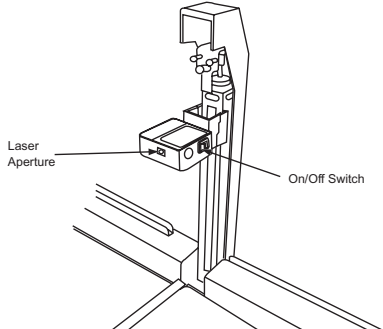
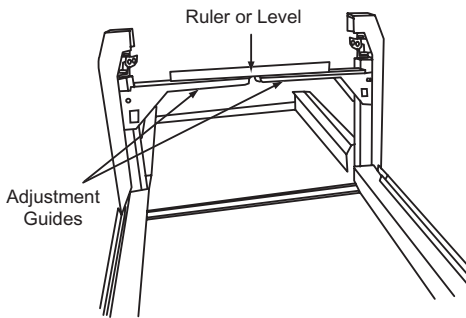
<ul style="list-style-type: none">• A laser alignment tool (LAT-1) allows field engineers to ensure that the sensor beam is aligned with the center of the opposite sensor stick.	
<ul style="list-style-type: none">• Two alignment guides (11001400) allow field engineers to ensure that the detection sticks are parallel to each other.	

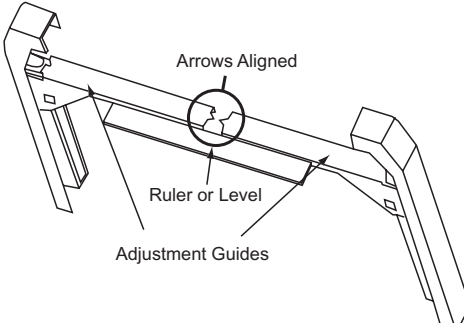
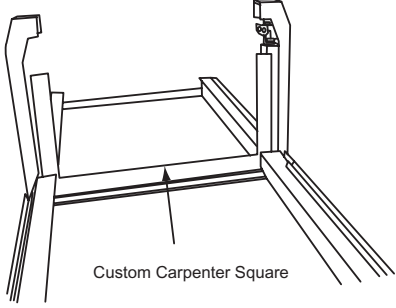
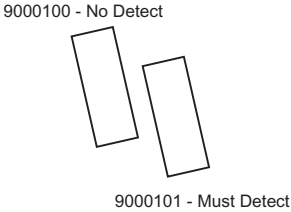
<ul style="list-style-type: none"> The arrow at the tip of each alignment guide also allows field engineers to ensure that the beam is aimed directly at the center of the detection stick. 	 <p>Arrows Aligned Ruler or Level Adjustment Guides</p>
<ul style="list-style-type: none"> A custom carpenter square allows field engineers to ensure that the detection sticks are parallel to each other. 	 <p>Custom Carpenter Square</p>
<ul style="list-style-type: none"> Two test shims (9000100 and 9000101) provide the required height of items that the sensor should detect or not detect. 	 <p>9000100 - No Detect 9000101 - Must Detect</p>

Earlier Casing Models

In casing version “D” and early casing “E” models, field engineers can adjust the height of the BANNER sensor array detection sticks by loosening the two nuts that secure the top bracket to the studs inside the sensor housing. This allows the field engineer to raise or lower the bracket and detection stick as required.

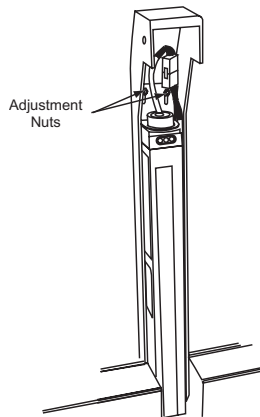

With this type of bracket, the only adjustment guides described above that can be used are the test shims.

SCANGINEER Sensor Array (Casing Version “C” and Earlier)

Field engineers can adjust the height of the SCANGINEER circuit boards by loosening the two upper adjustment screws that secure the circuit board to the bracket in the sensor housing. This allows the field engineer to raise or lower the circuit board as required.

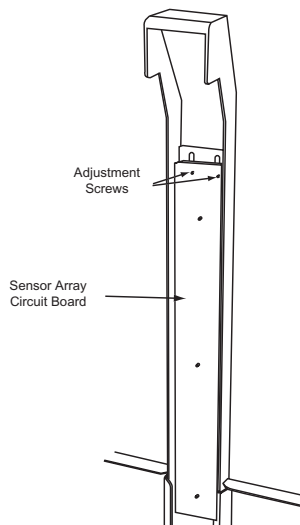

Take-Away and Collection Area Sensors

Field engineers remove the sensor bracket from the casing and adjust the sensor position by loosening the screws securing the sensor to the bracket and pivoting the sensor until it is in proper position.

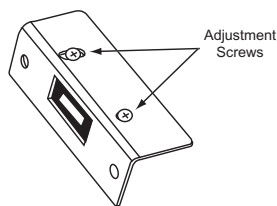

Preventive Maintenance for Field Engineers

Conveyor Belts

Field engineers should check the following on **every** service call:

- Tension of all belts
- Tracking of all belts

Refer to “[Adjusting the Belt Tension and Tracking](#)” on page 73 for instructions.

End-Access Plate



CAUTION:

Use caution when removing and replacing the end-access plate, because the take-away belt can begin moving if the sensor becomes blocked.

Ensure that the adjustment screws are not installed on the underside of the end-access plate. If the adjustment screws are present, **remove and discard them**. These screws can damage the belt if the plate is installed incorrectly and must be removed.

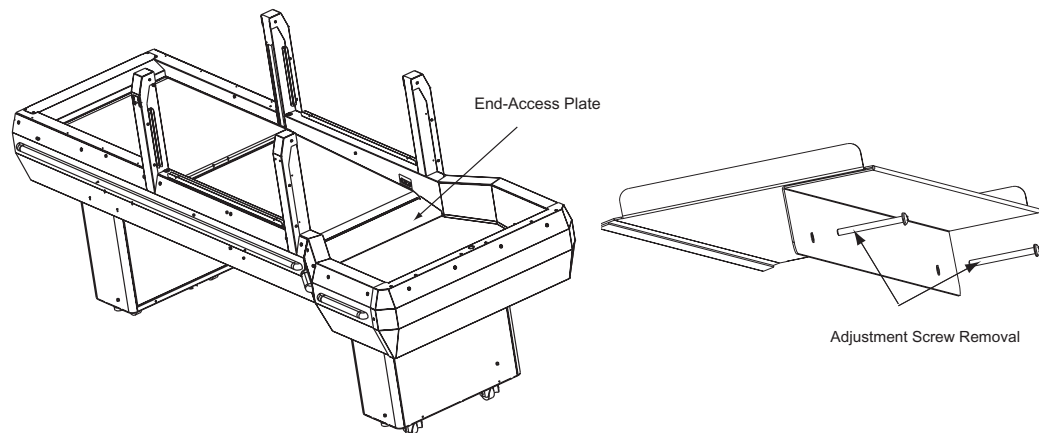

Sensor Array Pillars

Ensure that the sensor array pillars are firmly installed. If the pillars move easily, follow the steps below to replace the bolts securing the pillars.

1. Shut down the U-Scan Station.
2. Turn off the power switch on the controller board panel.
3. Remove the front and rear guards (Plexiglas pieces).
4. Remove the sensor faceplate for the pillar(s) you will secure.

-
5. Remove the skirt beside the pillar(s) you will secure.
 6. Remove the top nuts on both belts.
 7. **Loosen the belt tension adjustment nuts on both belts.**
 8. Lift the side of each belt that is closest to the pillar.
 9. Hold the pillar, then remove the four bolts and star washers (two each side) securing the pillar to the base.
 10. Fasten a 1/4 - 20 x 3/8" serrated flange bolt in each of the four holes to secure the pillar to the casing (torque = 70 inch lbs.).

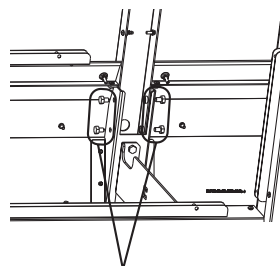

Serrated Flange Bolts (4)

NOTE: *You must replace all four bolts and washers with the serrated flange bolts. Do not re-use any of the original bolts and washers to secure the sensor pillars. Do not install the washers in combination with the serrated flange bolts.*

11. Discard the star washers and bolts you removed.
12. Lower both belts.
13. Install the locking nuts on the top of the both belts.
14. Replace the skirt.
15. Replace the sensor faceplate.
16. Replace the front and rear guards.
17. Restart the system.
18. Adjust the belt tension and tracking. Refer to [“Adjusting the Belt Tension and Tracking”](#) on page 73. Tighten the tension adjustment nuts when the belt is properly tracked.
19. Test the sensor array to ensure that the alignment is correct. Refer to [“Test the Sensors”](#) on page 57.
20. Adjust the sensor if necessary. Refer to [“Adjusting the Sensors”](#) on page 84.
21. Test the input belt scale to ensure that it is reading weight correctly. Refer to [“Testing the Belt Devices in the Device Tester”](#) on page 53.

U-Scan Max Hardware Testing

Hardware Operating Instructions

This chapter presents the following information:

- [Testing the Belt Devices from the Controller Board](#) (page 52)
- [Testing the Belt Devices in the Device Tester](#) (page 53)

Testing the Belt Devices from the Controller Board

Follow these steps if you need to advance the belts or test the take-away belt or collection area sensors without using the **Device Tester** software (i.e. when the Computer is off or when it is more convenient to use the controller board).

NOTE: *The sensor array (arch sensors) can only be tested in the **Device Tester**. Refer to “Test the Sensors” on page 57.*

1. Unlock and open the door beneath the input belt.
2. Loosen the two screws securing the controller board panel.
3. Open the controller board panel.
4. Locate the switches on the controller board.
5. Locate the alphabetically labeled LEDs on the controller board.
6. Refer to the table below for a list of the switch controls and LEDs.

Switch/LED	Switch Function	LED Function
A	Advances input belt	Lights when input belt is activated
C	Advances take-away belt	Lights when diverter belt is activated
M	N/A	Lights when take-away belt sensor is blocked
L	N/A	Lights when the collection area sensor is blocked.

7. To test the conveyor belts, activate the appropriate switch and ensure that the belt advances.

OR

To test the sensors, block the sensor you wish to test and ensure that the appropriate light on the controller board comes on.

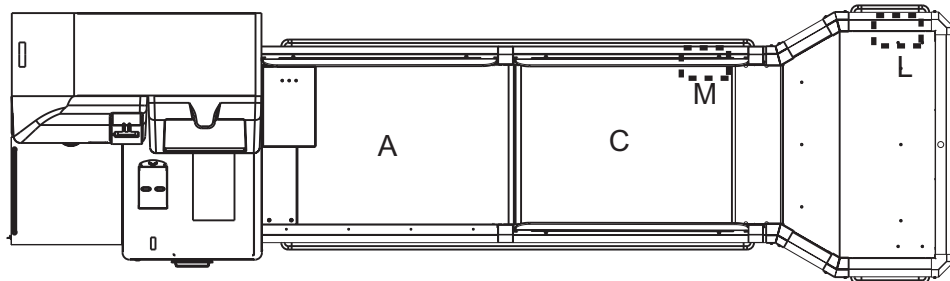

NOTE: *The sensor array can only be tested in the **Device Tester**. Refer to “Test the Sensors” on page 57.*

Testing the Belt Devices in the Device Tester

Follow these steps to test the diverter arm and conveyor belts in the **Device Tester**.

1. Check the Settings

1. Access the **Device Tester**.
 - a. Locate the Computer keyboard.
 - b. Press **ALT+TAB** and select the **Robot Control** window.
 - c. Touch **Stop Robot**.
The **Launchpad** appears.
 - d. Touch **Device Tester**.
 - e. Enter the password (**1379**), then touch **Done**.
The **Device Tester** appears.
2. Click the **Belted UScan Devices** tab.
3. Ensure that the settings are as shown below.

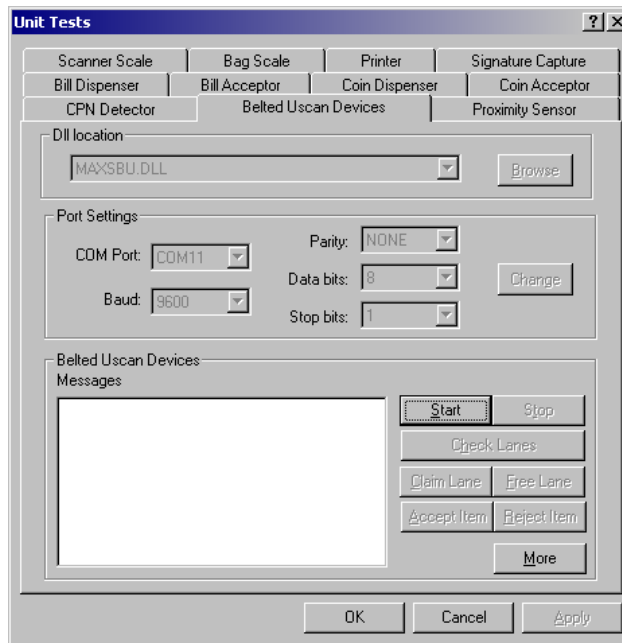

2. Test the Overall Functionality

1. On the **Belted UScan Devices** tab, click **Start**.

2. Ensure that the messages **Device::Online {USCAN_MAX_SBU}** and **DEVICE::ONLINE {BeltScale}** displays in the **Messages** box.

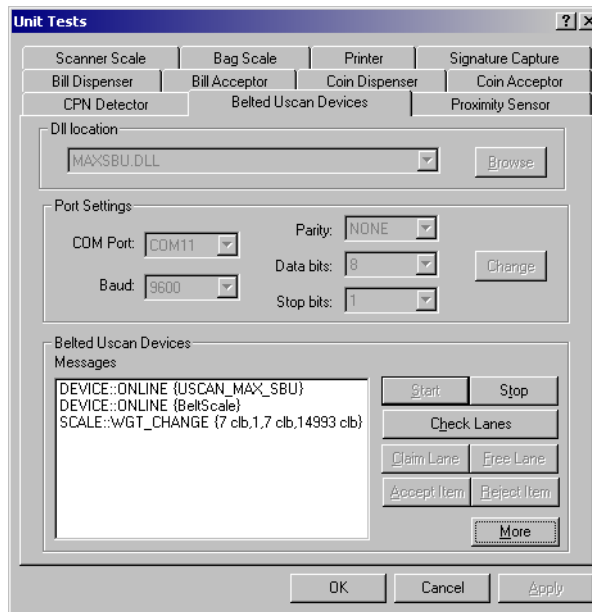

3. Click **Check Lanes**.
4. Ensure that the **UScanMax_LANE_CLEAR** message appears in the **Messages** box.

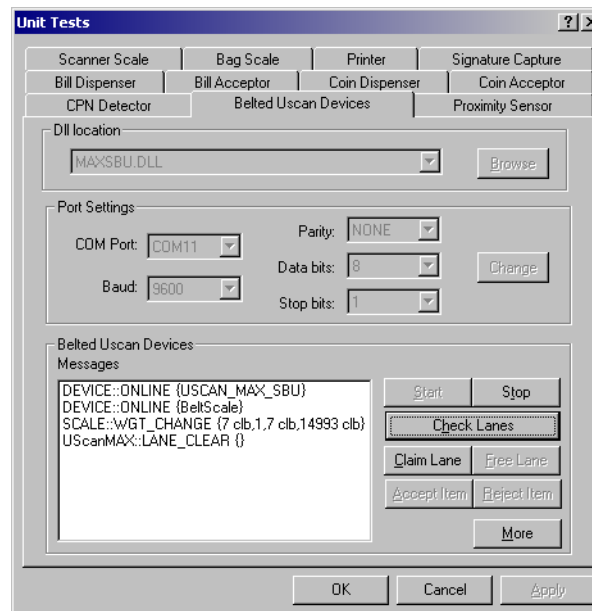

-
- Click **Claim Lane**.
The **UScanMAX_LANE_CLAIMED** message displays. The **Accept Item** and **Reject Item** buttons become enabled.

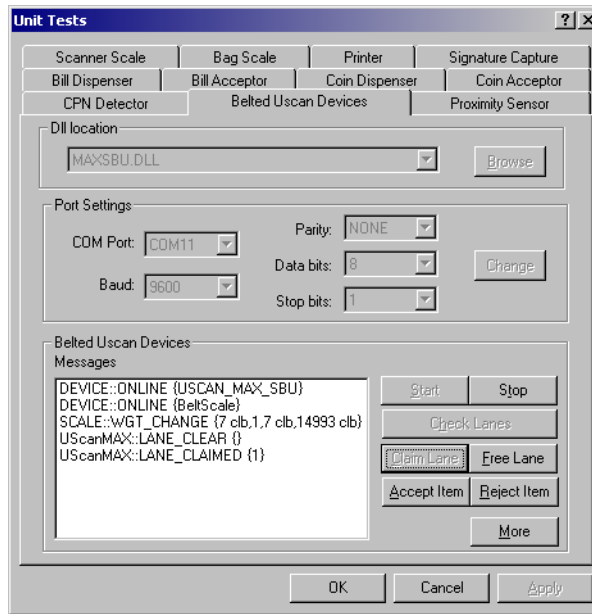

- Place an item on the input belt. Ensure that the weight change appears in the **Messages** box.
- Click **Accept Item**.
- Ensure that the input belt starts moving and that the item is moved through the sensor array, along the take-away belt and into the collection area.
- Click **Stop**.
- On the **Belted U-Scan Devices** tab, click **More**.
The **U-Scan Max SBU Components** screen appears.

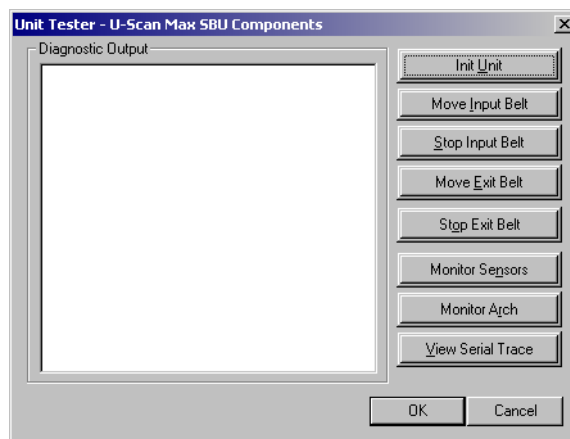

- Click **Init Unit**.

-
12. Ensure that the message **MaxSBU: Devices initialized and Ready** displays in the **Diagnostic Output** box.

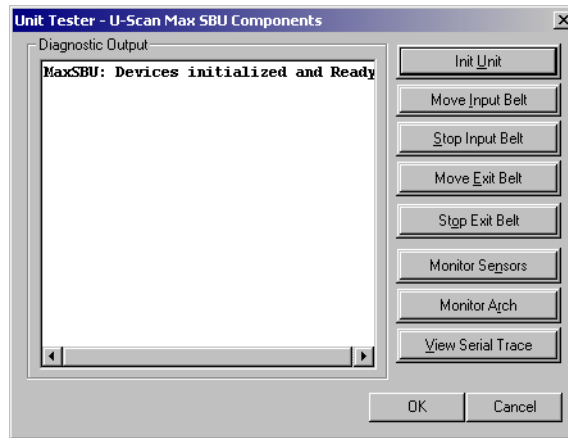

13. Click **OK**.

3. Test the Input Belt (Movement)

1. On the **Belted U-Scan Devices** tab, click **More**.
The **U-Scan Max SBU Components** screen appears.

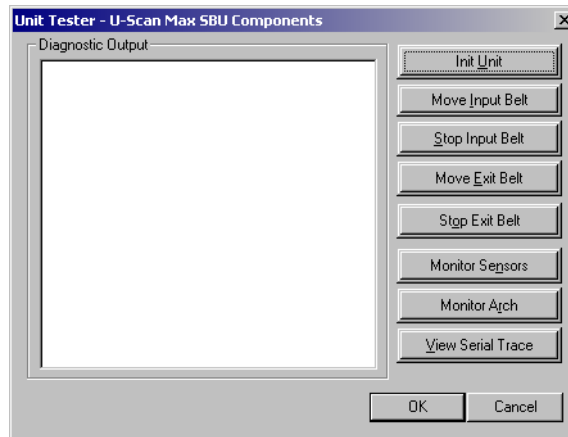

2. Click **Move Input Belt**.
3. Ensure that the input belt advances and that the message **Max SBU: Success, Input Belt moving forward** displays.
4. Click **Stop Input Belt**.

-
5. Ensure that the input belt stops and that the message **MaxSBU: Input Belt Stopped** displays.

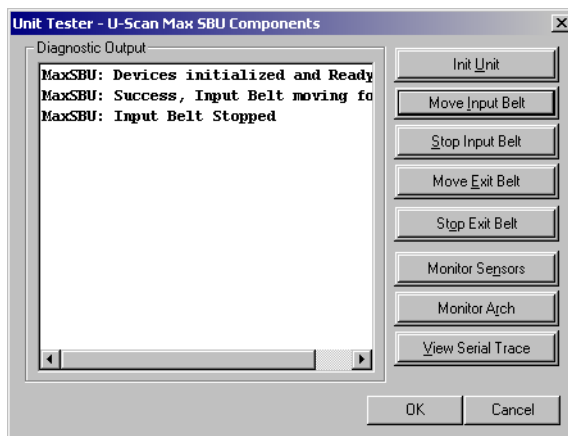

4. Test the Take-Away Belt

Select **Move Exit Belt** and **Stop Exit Belt** to ensure that the take-away belt moves.

5. Test the Sensors

Follow these steps to test the sensor array and take-away and collection area sensors.

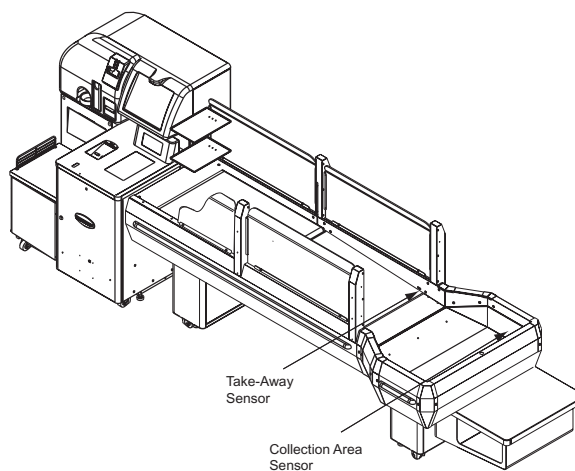

1. On the **Belted U-Scan Components** screen, click **Monitor Sensors** to test the take-away belt and collection area sensors.

OR

Click **Monitor Arch** to test the sensor array.

2. Place an item on the belt in front of the sensors you wish to test.
3. Wait one second, then remove it.

4. Ensure that a line of text appears in the **Diagnostic Output** box. Refer to the table below for the appropriate text.

Sensor	Text
Take-away belt sensor	AML or AMH
Collection area sensor	ALL or ALH
Sensor array	Trigger data (1)^a Object data Trigger data (0)^b

a. Appears when the sensor beam is interrupted.

b. Appears when the object is removed from the sensor beam.

5. Click **Stop Monitoring** to complete the test of the take-away belt sensors.

OR

Click **Stop Arch Monitor** to complete the test of the sensor array.

If the sensors need to be adjusted, refer to [“Adjusting the Sensors”](#) on page 61.

6. Test the Input Belt Scale

To test the input belt scale while it is stationary,

1. In the **Device Tester**, click the **Bag Scale** tab.

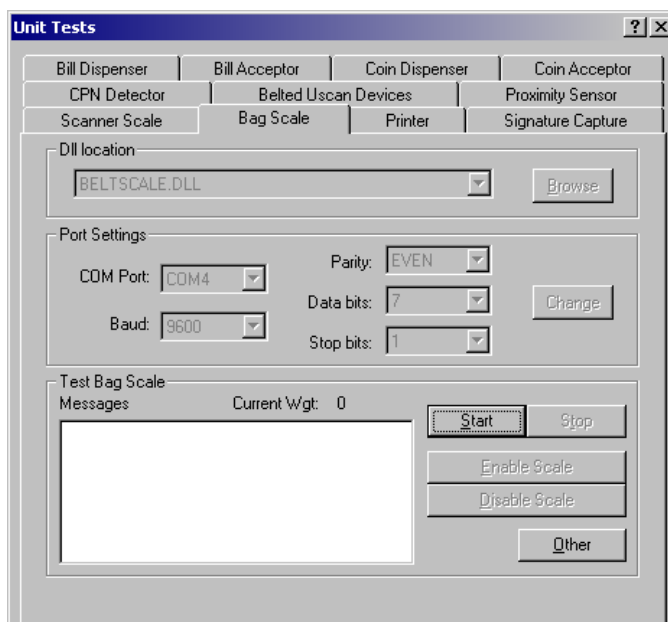

2. Click **Start**.

-
3. Click **Enable Scale**.

The current weight is displayed in the **Messages** box.

NOTE: *If the **Enable Scale** button is disabled, the current weight is already displayed in the **Messages** box.*

4. Put an object on the scale and read the weight.
5. Weigh the object on different areas of the scale to ensure that the weight is constant and accurate. A discrepancy of 2 clb. is acceptable when the scale is not moving.
6. Click **Stop**.
7. Exit the **Device Tester**.

To test the input belt scale while it is in motion,

1. In the **Device Tester**, click the **Bag Scale** tab.

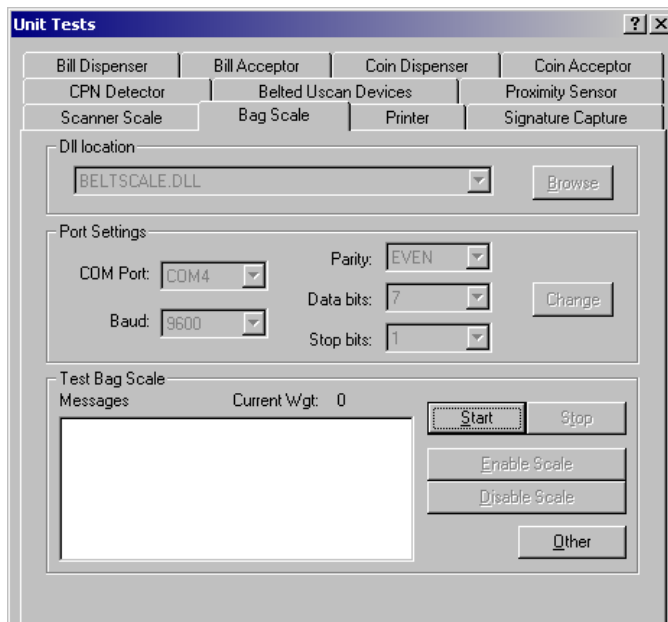

2. Click **Start**.

3. Click **Enable Scale**.

The current weight is displayed in the **Messages** box.

NOTE: *If the **Enable Scale** button is disabled, the current weight is already displayed in the **Messages** box.*

4. Click the **Belted U-Scan Devices** tab.

-
5. Click **More**.
The **U-Scan Max SBU Components** window displays.

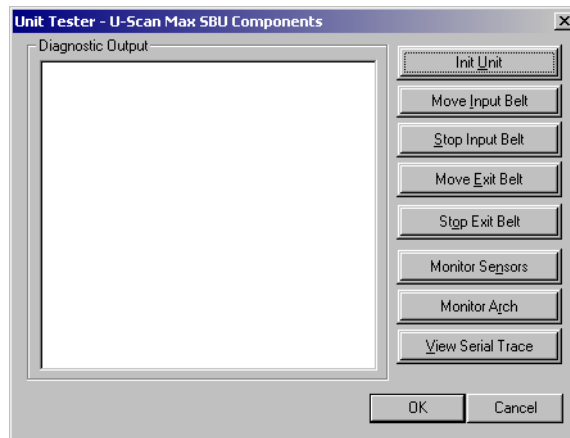

6. Position the **U-Scan Max SBU Components** window so that it is beside the main **Device Tester** window.
7. In the main **Device Tester** window, click the **Bag Scale** tab.
The **Bag Scale** tab and the **U-Scan Max SBU Components** window should display side by side.
8. In the **U-Scan Max SBU Components** window, click **Move input belt**.
9. Monitor the weight changes in the **Messages** box on the **Bag Scale** tab.
10. Ensure that the weight does not fluctuate more than **5 clb**.
11. Ensure that the weight value is 0 when the item leaves the belt.
12. Click **OK** in the **U-Scan Max SBU Components** window.
13. Exit the **Device Tester**.

U-Scan Max Hardware Troubleshooting

This chapter presents the following information:

- [Zeroing the Input Belt Scale](#) (page 62)
- [Calibrating the Input Belt Scale](#) (page 64)
- [Setting the Input Belt Scale Filter Settings](#) (page 68)
- [Verifying the Elevation and Latitude](#) (page 70)
- [Adjusting the Belt Devices](#) (page 73)
- [Adjusting the Sensors](#) (page 84)

Zeroing the Input Belt Scale

Perform this procedure if the scale reports a value other than **0** when nothing is on the scale.

Performing a Hard Zero Through HyperTerminal

1. Start a new HyperTerminal session:
 - a. Go to **Start > Programs > Accessories > Communications > HyperTerminal**.

NOTE: *If **HyperTerminal** is not present at the path above, see the alternate instructions below.*

 - b. Click **HyperTerminal**.
 - c. Enter a name for the session, then press **ENTER**.

OR

 - a. Go to **Start > Run**.
 - b. Enter **Hypertrm**.
 - c. Press **ENTER**.
 - d. Enter a name for the session, then press **ENTER**.
2. On the **Connect to** screen, select **COM4** from the drop-down list.
3. On the **COM4 Properties** screen, enter the following communication settings:
 - a. Baud Rate: **9600**
 - b. Data Bits: **7**
 - c. Parity: **Even**
 - d. Stop Bits: **1**
 - e. Handshake *or* Flow Control: **None**
4. Ensure that the text **Connected** appears in the bottom left corner of the **HyperTerminal** window.

NOTE: *If **Connected** does not appear, choose **Call** from the window menus, and then choose **Connect**.*
5. When the session is running (connected), enter **/TEST** to view the **RL Scales** menu.

NOTE: *Use the **CAPS LOCK** key and **NOT** the **SHIFT** key to capitalize “TEST.”*
6. Enter **h** to perform a hard zero.
7. Enter **m** to exit.
8. Disconnect the HyperTerminal session.

Performing a Soft Zero Through Device Tester

1. Access the **Device Tester**.
 - a. Locate the Computer keyboard.
 - b. Press **ALT+TAB** and select the **Robot Control** window.
 - c. Touch **Stop Robot**.
The **Launchpad** appears.
 - d. Touch **Device Tester**.
 - e. Enter the password (**1379**), then touch **Done**.
The **Device Tester** appears.
2. In the **Device Tester**, click the **Bag Scale** tab.

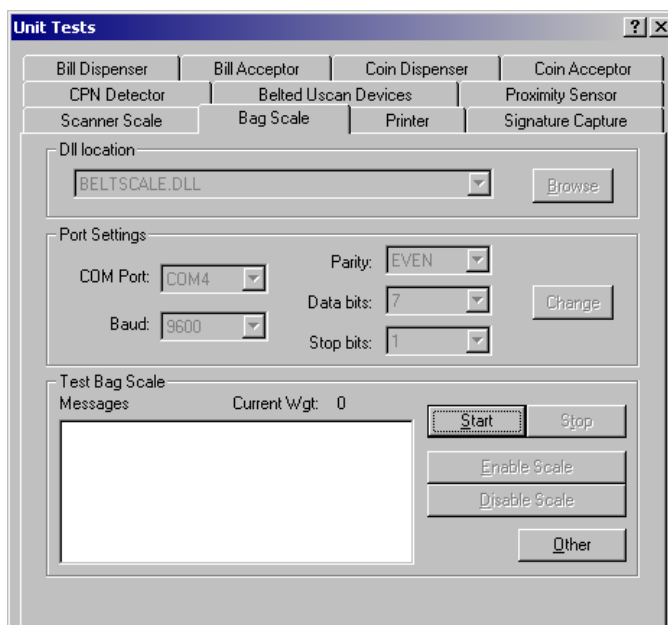

3. Click **Other**.
The **Belt Scale Unit Dialog** screen appears.
4. From the drop-down list, select **Z** to zero the scale.
5. Test the input belt scale. Refer to [“Test the Input Belt Scale”](#) on page 58.
6. If the issue is not resolved, recalibrate the input belt scale. Refer to [“Setting the Input Belt Scale Filter Settings”](#) on page 68.

Calibrating the Input Belt Scale

Calibrating the Input Belt Scale through HyperTerminal - Auto-Calibration Method

Calibrate the input belt scale through HyperTerminal to troubleshoot the belt scale. Perform this procedure if weight violations occur while an item is being moved along the belt or if the scale is weighing inaccurately. This calibration method will allow you to determine if weight reading fluctuations occur while the belt is in motion.

1. Make sure that there is no interference with the load cells. For example, make sure that no cables are touching the load cells.
2. Start a new HyperTerminal session:
 - a. Go to **Start > Programs > Accessories > Communications > HyperTerminal**.

NOTE: *If **HyperTerminal** is not present at the path above, see the alternate instructions below.*

- b. Click **HyperTerminal**.
- c. Enter a name for the session, then press **ENTER**.

OR

- a. Go to **Start > Run**.
 - b. Enter **Hypertrm**.
 - c. Press **ENTER**.
 - d. Enter a name for the session, then press **ENTER**.
3. On the **Connect to** screen, select **COM4** from the drop-down list.
 4. On the **COM4 Properties** screen, enter the following communication settings:
 - a. Baud Rate: **9600**
 - b. Data Bits: **7**
 - c. Parity: **Even**
 - d. Stop Bits: **1**
 - e. Handshake *or* Flow Control: **None**
 5. Ensure that the text **Connected** appears in the bottom left corner of the **HyperTerminal** window.

NOTE: *If **Connected** does not appear, choose **Call** from the window menus, and then choose **Connect**.*

6. When the session is running (connected), enter **/TEST** to view the **RL Scales** menu.

NOTE: *Use the **CAPS LOCK** key and **NOT** the **SHIFT** key to capitalize “**TEST**.”*

-
7. Enter **C** to calibrate the scale.
The **Calibration** menu options display.
 8. Remove all items from the input belt scale.
 9. Enter **A** to select the auto-calibration method.
 10. Wait for the auto-calibration procedure to complete. Do **NOT** touch the scale during this process.
 11. After calibration is complete, place a weight in the middle of the scale.
 12. Ensure that the weight displayed in the **Scale Calibration** window is correct.
 13. Repeat to verify that the weight is constant in each of the four corners.
NOTE: *A fluctuation of .02 lb. (2 clb.) is acceptable.*
 14. Access the controller board and turn on switch A to run the input belt.
 15. Place a 1 lb. weight on the moving belt and ensure that a stable weight is recorded.
 16. Allow the input belt to run for 1-2 minutes to ensure that no weight fluctuations greater than 0.05 lb. (5 clb.) occur while the scale is in motion. Keep replacing the item on the moving belt during this time.
 17. If the calibration did not work,
 - a. Ensure that none of the scale cables is touching the scale.
 - b. Ensure that the loop on the belt motor cable is not touching the side of the casing.
 - c. If the scale is underweighing, ensure that the **PGA Gain** in the **Scale Calibration** window is set to **8**.
 - d. If necessary, calibrate the scale manually.
 18. Enter **m** to exit.
 19. Disconnect the HyperTerminal session.

Calibrating the Input Belt Scale through HyperTerminal - Manual Calibration with Weights

Calibrate the input belt scale with weights if the auto-calibration method is unsuccessful (i.e. if the scale is not reading weight correctly after calibration).

Recommended Calibration Weight:

50 lbs.

Maximum Scale Capacity:

75 lbs.

1. Make sure that there is no interference with the load cells. For example, make sure that no cables are touching the load cells.
2. Start a new HyperTerminal session:
 - a. Go to **Start > Programs > Accessories > Communications > HyperTerminal**.

NOTE: *If **HyperTerminal** is not present at the path above, see the alternate instructions below.*

- b. Click **HyperTerminal**.
- c. Enter a name for the session, then press **ENTER**.

OR

- a. Go to **Start > Run**.
 - b. Enter **Hypertrm**.
 - c. Press **ENTER**.
 - d. Enter a name for the session, then press **ENTER**.
3. On the **Connect to** screen, select **COM4** from the drop-down list.
 4. On the **COM4 Properties** screen, enter the following communication settings:
 - a. Baud Rate: **9600**
 - b. Data Bits: **7**
 - c. Parity: **Even**
 - d. Stop Bits: **1**
 - e. Handshake *or* Flow Control: **None**
 5. Ensure that the text **Connected** appears in the bottom left corner of the **HyperTerminal** window.

NOTE: *If **Connected** does not appear, choose **Call** from the window menus, and then choose **Connect**.*

-
6. When the session is running (connected), enter **/TEST** to view the **RL Scales** menu.

NOTE: Use the **CAPS LOCK** key and **NOT** the **SHIFT** key to capitalize “TEST.”

7. Enter **C** to calibrate the scale.
8. Enter **W** to calibrate the scale with weights.
9. Follow the on-screen instructions to complete the calibration.

NOTES: *The system prompts you to use at least 40 lbs. Make sure that you use at least 50 lbs. for accurate calibration.*

The elevation and latitude field values entered are not relevant when calibrating with weights. Use the default values.

10. After calibration is complete, place a weight in the middle of the scale.
11. Ensure that the weight displayed in the **Scale Calibration** window is correct.
12. Repeat to verify that the weight is constant in each of the four corners.

NOTE: *A fluctuation of .02 lb. (2 clb.) is acceptable.*

13. Access the controller board and turn on switch A to run the input belt.
14. Place a 1 lb. weight on the moving belt and ensure that a stable weight is recorded.
15. Allow the input belt to run for 1-2 minutes to ensure that no weight fluctuations greater than 0.05 lb. (5 clb.) occur while the scale is in motion. Keep replacing the item on the moving belt during this time.
16. If the calibration did not work,
 - a. Ensure that none of the scale cables is touching the scale.
 - b. Ensure that the loop on the belt motor cable is not touching the side of the casing.
 - c. If the scale is underweighing, ensure that the **PGA Gain** in the **Scale Calibration** window is set to **8**.
17. Exit the **Scale Calibration** window.

Setting the Input Belt Scale Filter Settings

Verify the input belt scale settings if weight violations occur while the input belt is in motion.

1. Start a new HyperTerminal session:
 - a. Go to **Start > Programs > Accessories > Communications > HyperTerminal**.

NOTE: *If **HyperTerminal** is not present at the path above, see the alternate instructions below.*

- b. Click **HyperTerminal**.
 - c. Enter a name for the session, then press **ENTER**.

OR

- a. Go to **Start > Run**.
 - b. Enter **Hypertrm**.
 - c. Press **ENTER**.
 - d. Enter a name for the session, then press **ENTER**.

2. On the **Connect to** screen, select **COM4** from the drop-down list.
3. On the **COM4 Properties** screen, enter the following communication settings:

- a. Baud Rate: **9600**
 - b. Data Bits: **7**
 - c. Parity: **Even**
 - d. Stop Bits: **1**
 - e. Handshake *or* Flow Control: **None**

4. Ensure that the text **Connected** appears in the bottom left corner of the **HyperTerminal** window.

NOTE: *If **Connected** does not appear, choose **Call** from the window menus, and then choose **Connect**.*

5. When the session is running (connected), enter **/TEST** to view the **RL Scales** menu.

NOTE: *Use the **CAPS LOCK** key and **NOT** the **SHIFT** key to capitalize “TEST.”*

6. When at the **/TEST** menu, enter **9625**.
7. Press **F** to access the **Filter/SIM Settings** menu.

8. Ensure that the settings are set to the following values:

Setting	Value
[1] Low Pass Filter Tap	6

Setting	Value
[2] Running Avg. Filter Depth	5
[3] SIM Buffer	8
[4] SIM ON	4
[5] SIM OFF	3

9. If you need to modify a setting, follow the steps below:
- Press the number corresponding to the setting you wish to modify. For example, if you wish to modify the **[3] SIM Buffer** setting, press **3**.
 - To increase the value of the setting, press **U** until the appropriate value displays.
OR
 - To decrease the value of the setting, press **D** until the appropriate value displays.
10. When all settings are correct, press **ESC, ESC**.
The changes save automatically and HyperTerminal exits.

Verifying the Elevation and Latitude

Perform this procedure after you install the U-Scan system in a store or if you replace a load cell.

1. Start a new HyperTerminal session:
 - a. Go to **Start > Programs > Accessories > Communications > HyperTerminal**.

NOTE: *If **HyperTerminal** is not present at the path above, see the alternate instructions below.*

- b. Click **HyperTerminal**.
 - c. Enter a name for the session, then press **ENTER**.

OR

- a. Go to **Start > Run**.
 - b. Enter **Hypertrm**.
 - c. Press **ENTER**.
 - d. Enter a name for the session, then press **ENTER**.

2. On the **Connect to** screen, select **COM4** from the drop-down list.
3. On the **COM4 Properties** screen, enter the following communication settings:
 - a. Baud Rate: **9600**
 - b. Data Bits: **7**
 - c. Parity: **Even**
 - d. Stop Bits: **1**
 - e. Handshake *or* Flow Control: **None**

4. Ensure that the text **Connected** appears in the bottom left corner of the **HyperTerminal** window.

NOTE: *If **Connected** does not appear, choose **Call** from the window menus, and then choose **Connect**.*

5. When the session is running (connected), enter **/TEST** to view the **RL Scales** menu.

NOTE: *Use the **CAPS LOCK** key and **NOT** the **SHIFT** key to capitalize “TEST.”*

6. Enter **c** to access calibration mode.
7. Enter **c** again to view the elevation and latitude settings.
8. Ensure that the settings are correct for your location.
9. If necessary, enter the correct elevation and / or latitude.

-
10. If you do not know the correct elevation or latitude, refer to “[Determining Latitude](#)” on page 71 or “[Determining Elevation](#)” on page 71.
 11. Press **m** to exit HyperTerminal.

Determining Latitude

Option 1:

1. On a map, locate the city and determine which latitude lines it lies between.
2. Halve the difference and enter this number.
EXAMPLE: Atlanta, GA is between the 30 and 35 degree lines. Enter **32.5**.

Option 2:

Go to the following link to locate the latitude for **major US and Canadian cities**
<http://www.infoplease.com/ipa/A0001796.htm>.

For major cities outside North America, go to the link above, then click **Latitude and Longitude of World Cities**.

Determining Elevation

Option 1 (USA)

1. Access the following link <http://geonames.usgs.gov/pls/gnispublic/>.
2. In the **State or Territory** field, select the state of the installation.
3. In the **Feature Class** field, select **Populated Place**.
A list of towns and elevations in the state displays.

Option 2 (Canada)

1. Go to the following link <http://www.postalcodedownload.com/>.
2. Select the Province.
3. Select the 3 first characters of the store’s postal code.
4. Select the store’s postal code from the results page.
A page with details including the elevation appears.

Option 3 (Canada)

1. Go to the following link <http://atlas.gc.ca/site/english/maps/reference/national/reliefinteractive>.
2. Click **Zoom to Region**.
3. Select the Province from the drop-down list.
4. Select the City from the drop-down list.
5. Refer to the colored **Land Relief** chart on the right side to determine the elevation in METERS.

Option 4 (Outside North America)

1. Go to the following link <http://www.fallingrain.com/world/>.
2. Select the Country.
3. Select the Province.
4. Select the first letter of the city.
5. Locate the city on the list that appears.
6. Note the elevation in FEET and the latitude.

Adjusting the Belt Devices

This section contains the following procedures:

- [Adjusting the Belt Tension and Tracking](#) (page 73)
- [Adjusting the Belt Position \(Front-Back\)](#) (page 81)
- [Adjusting the Transfer Bar Height](#) (page 77)
- [Adjusting the Belt Height](#) (page 82)

Adjusting the Belt Tension and Tracking

If the belt is not rolling properly or you are able to stop the belt by applying pressure, adjust the belt tension.

If the input belt scale is recording fluctuating weight readings while in motion, tighten the belt. (A fluctuation of 5 clb. is acceptable while the belt is in motion.)

1. Remove the Front Guard Plate or End-Access Plate (As Required)

If you are adjusting the input belt:

1. Locate the front guard plate beside the input belt.

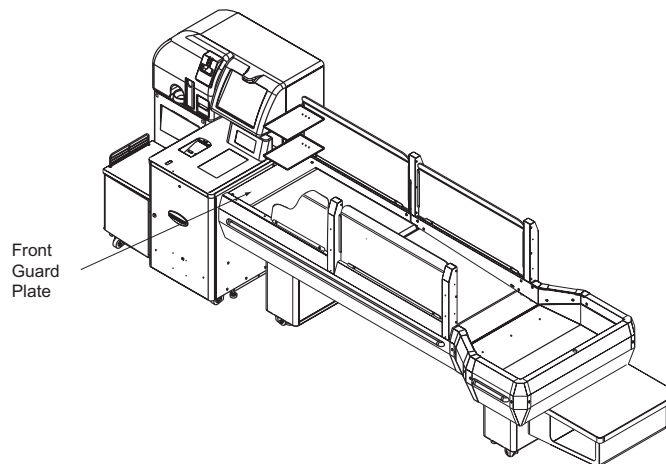

2. Use a Phillips screwdriver to remove the four 8-32 screws securing the front guard plate to the casing. Set aside.
3. Remove the front guard plate.

If you are adjusting the take-away belt:

1. For casing models “E” and later, lift the collection area plate out of the collection area.

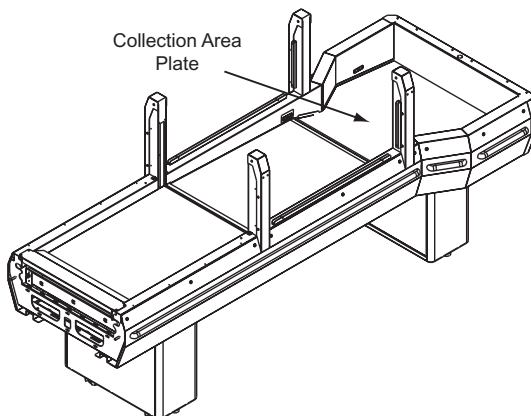

2. Lift the end-access plate off the unit.

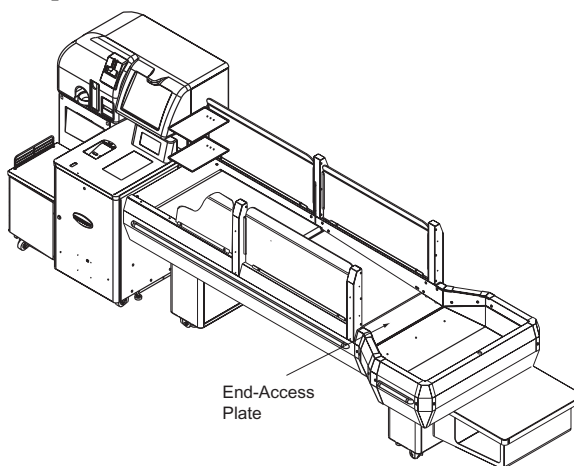

2. Remove the External Printer Shelf (If Necessary)

Some stores have two external Printer shelves installed on the unit. If it prevents you from accessing the adjustment nuts, remove the lower external Printer shelf.

1. Disconnect the cables from the Printer.
2. Remove the Printer from the Printer shelf.
3. Remove the back panel of the main unit.
4. From the inside of the casing, use an adjustable wrench to remove the four Keps nuts securing the Printer shelf.
5. Remove the Printer shelf.

3. Adjust the Belt Tension and Tracking

1. Refer to “[Guide to Gauging the Conveyor Belt Tension](#)” on page 31 for guidelines that will help you gauge the correct belt tension.
2. Access the controller board. It is installed in the Computer compartment above the Computer.
3. Lift switch A to start the input belt.

OR

Lift switch C to start the take-away belt.

4. While the belt is running, gauge how the belt needs to be adjusted (looser, tighter, more tension on one side, etc.).
5. Stop the belt.
6. Locate the adjustment nuts on either side of the belt frame. They are always on the motor side of the belt.

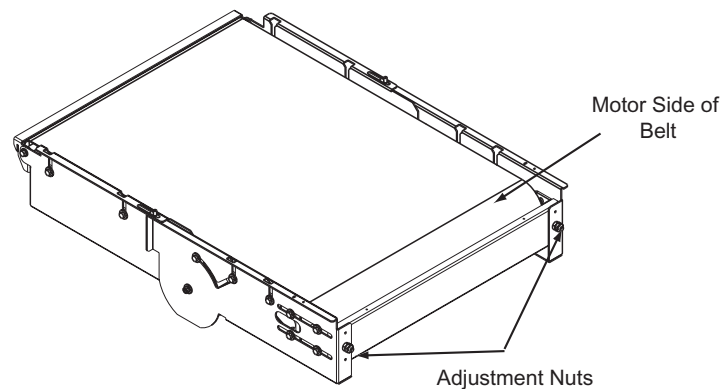

7. Loosen the outer nut on either side.
8. If the belt requires more tension, use an adjustable wrench to slightly tighten the **inner** nuts. Loosen the inner nuts if the belt requires less tension.

NOTES: Do **NOT** overtighten the nuts.

The belt may only need to be adjusted on one side. In this case, adjust only the appropriate nut.

9. Tighten the outer nuts.
10. Start the belt again and let it run for approximately 2-3 minutes to allow it to adjust to the changes made.
11. Make sure that the belt is centered on the idler and is not running more toward one side.
12. Make sure that the belt is approximately 1/8” away from the side of the frame.
13. Place your hands on the belt and apply reasonable pressure.

-
14. Make sure that the belt does not slip when you apply reasonable pressure.
 15. If the belt requires further adjustment, adjust the nuts with the belt running.
 16. When the belt is adjusted, allow the belt to run for approximately 10 minutes.
 17. Monitor the belt while it is running for tension and tracking.
 18. Stop the belt.
 19. Adjust the belt if necessary.

4. Reassemble the Unit

1. Replace the front guard plate or end-access plate.
2. If necessary, replace the collection area plate.
3. If necessary, replace the external Printer shelf:
 - a. Align the pem studs on the Printer shelf support with the holes on the side of the casing.
 - b. Fasten the four Keps nuts you removed earlier.
 - c. Set the Printer on the shelf.
 - d. Connect the Printer cables.
 - e. Replace the back panel on the main unit.

Adjusting the Transfer Bar Height

Adjustment Guide:

- Adjust the transfer bar so that it **slopes down 3-5°** towards the take-away belt.
- Adjust the transfer bar so that the **gap** between the bar and take-away belt is 0.090 - 0.12" (3/32 - 1/8").

1. Remove the Front and Rear Guards Beside the Take-Away Belt

1. Locate the two screws securing the front guard beside the take-away belt to the metal tracks on the skirt.

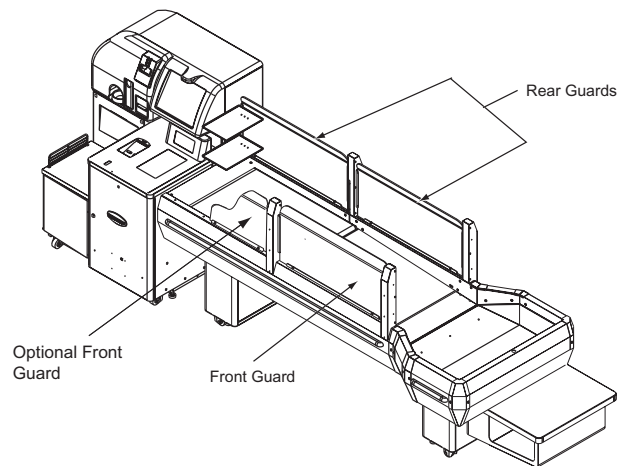

2. Remove the screws.
3. Lift the Plexiglas up and out of the tracks.
4. Repeat the steps above for the rear guard beside the take-away belt.

2. Remove the Sensor Faceplates

Use a Phillips screwdriver to remove the eight screws securing the sensor faceplate to the sensor housing.

NOTE: *Two of the screws are on the tabs on the sensor faceplate base.*

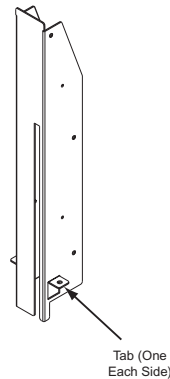

3. Remove the Front and Rear Skirts Beside the Take-Away Belt

1. Locate the screws securing the front skirt beside the take-away belt.
2. Remove the screws.
3. Lift the skirt off the unit. **Do NOT hit the sensor arrays with the skirt.**
4. Repeat the steps above for the rear skirt beside the take-away belt.

4. Adjust the Transfer Plate Height

1. Locate the transfer plate. It is installed on the idler on the input belt.
2. Lift and pivot the transfer plate up towards the input belt to access the two adjustment screws.

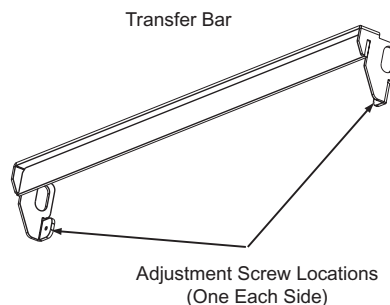

3. To lower the transfer plate height, tighten the two screws.

OR

To raise the transfer plate height, loosen the two screws.

4. Pivot the transfer plate back into place.
5. If available, set the transfer bar adjustment gauge into place to ensure that the transfer bar **slopes down 3-5°** towards the take-away belt.

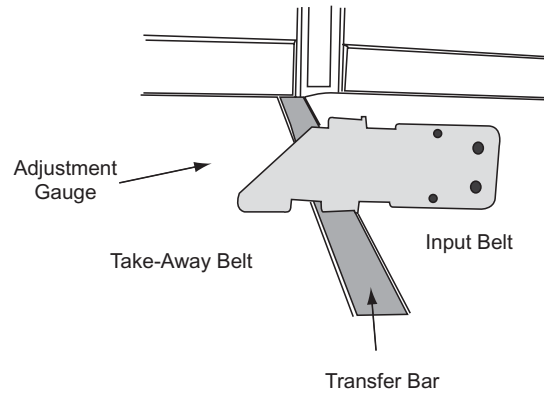

6. Ensure that the gap between the take-away belt and the transfer bar is the thickness of the thinner test shim (9000100) for the length of the bar or that the gap measures **3/32 - 1/8"**.

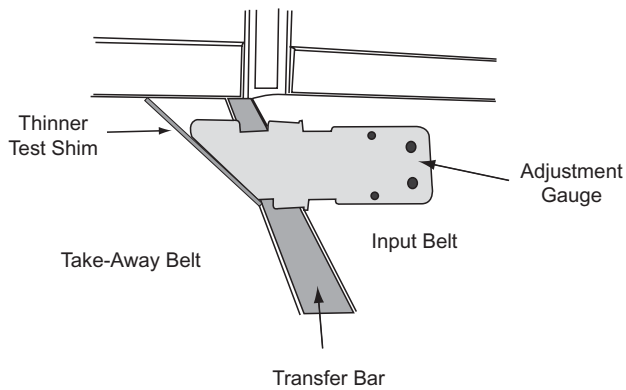

7. If necessary, adjust one or both screws.

-
- Turn the adjustment gauge the other way to gauge the height of the take-away belt.

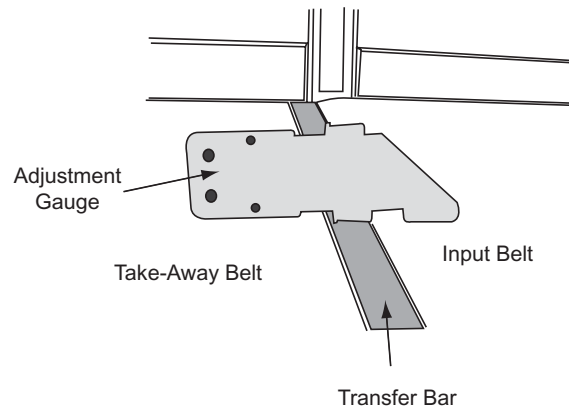

- If necessary, adjust the take-away belt height.
- Remove the adjustment gauge from the belt, then turn on switches A and C on the controller board.
- Ensure that items can be moved easily from the input belt to the take-away belt.
- Stop the belts.

5. Reassemble the Unit

- Replace the front and rear skirts beside the take-away belt.
- Replace the sensor faceplates.
- Replace the front and rear guards beside the take-away belt.

Adjusting the Belt Position (Front-Back)

1. On the underside of the conveyor frame, locate the four slotted holes for the belt you wish to adjust.

NOTE: *On earlier casing versions, you need to lower both crumb trays to access the bolts.*

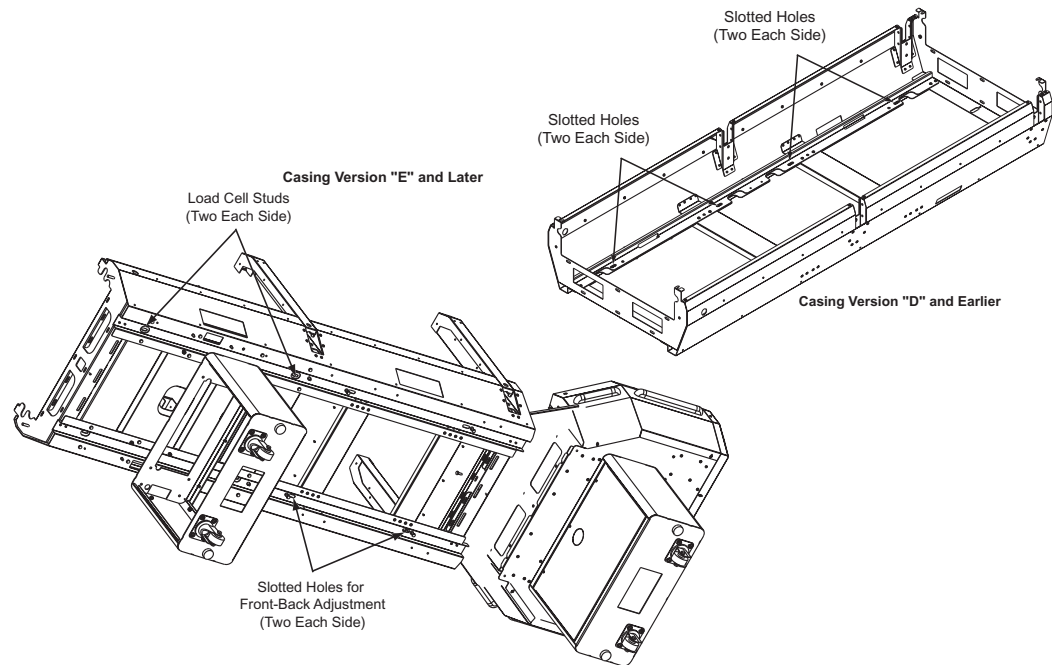

2. Loosen the bolts in the holes.

OR

To adjust the input belt on casing versions “E” and later, loosen the nuts on the load cells.

3. From the top of the conveyor unit, slide the belt frame forward or backward until it is in the desired position.
4. If you are adjusting the take-away belt, ensure that the belt is not rubbing on the transfer plate on the input belt.
5. Ensure that the gap is not too large between the transfer plate on the input belt and the front of the take-away belt.
6. Fully tighten the four adjustment bolts.

Adjusting the Belt Height

NOTE: On casing version "E" and later, the height of the **input belt cannot be adjusted.**

1. On the underside of the conveyor frame, loosen the four nuts or bolts that secure the belt frame to the bottom plate.

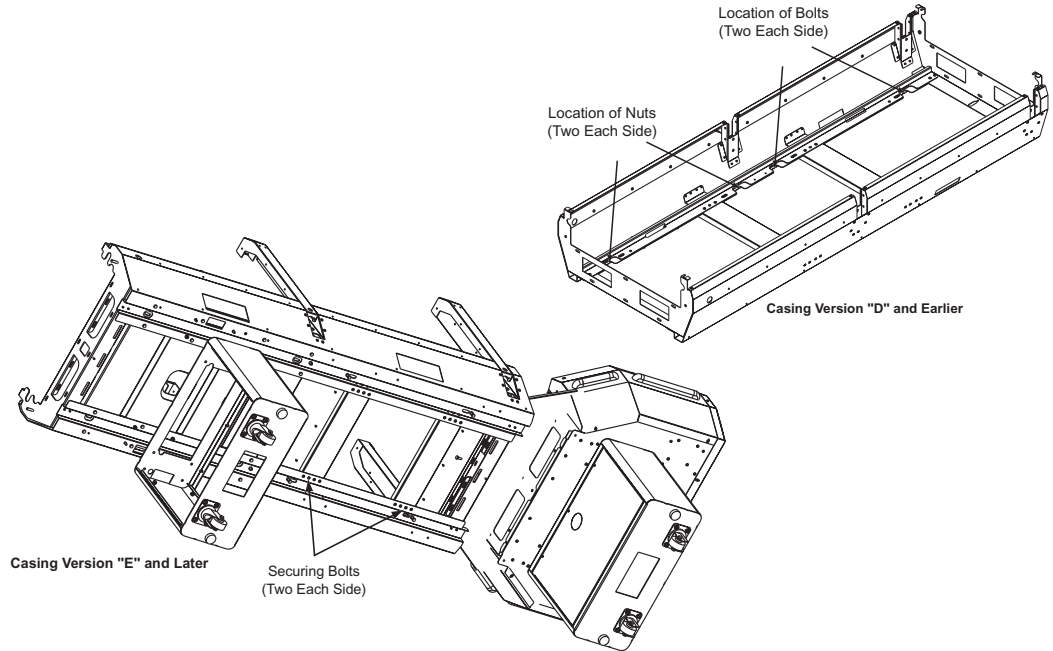

2. On the underside of the conveyor frame, locate the four height adjustment bolts for the belt you wish to adjust.

NOTE: On earlier casing versions, you need to lower both crumb trays to access the bolts.

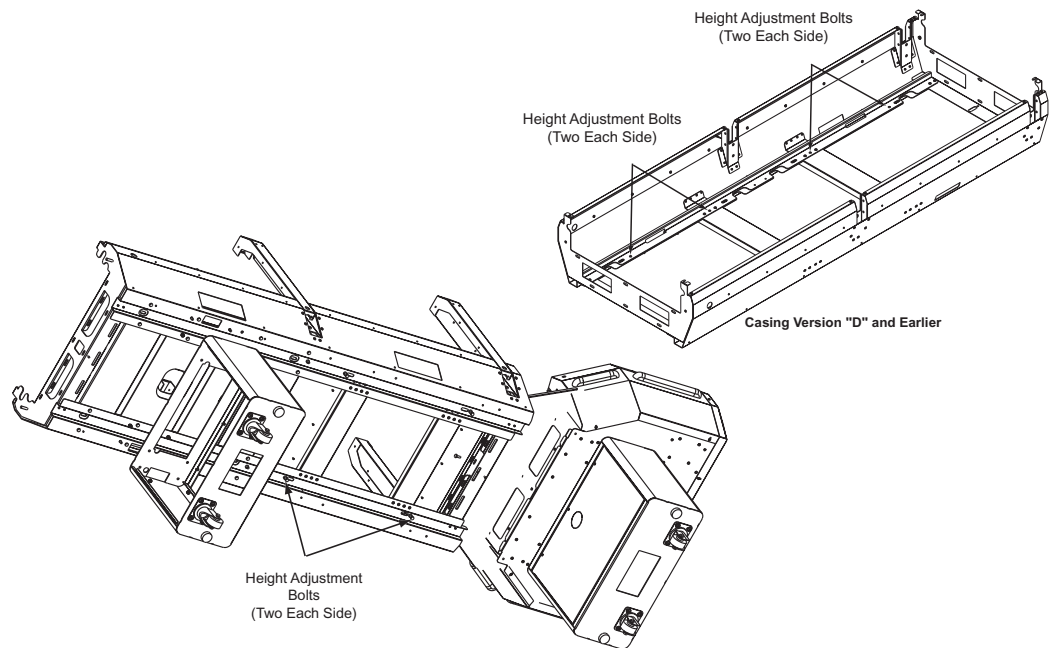

-
3. To raise the belt level, tighten the four bolts until the belt is at the desired height.



OR

To lower the belt level, loosen the four bolts until the belt is at the desired height.

4. If you are adjusting the input belt, use a carpenter level to ensure that the belt is level front to back and side to side.
5. If necessary, tighten or loosen the necessary bolt(s) to level the belt.
6. Once the belt is in the proper position, tighten the four nuts or bolts that secure the belt frame.

Adjusting the Sensors

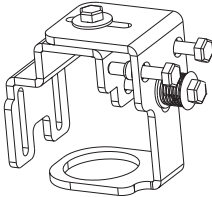
This section contains procedures for adjusting all sensor types on all casing models installed in stores and store labs. Refer to the table below to help you choose the correct procedure.

Sensor Type	Casing Model / Description	Procedure(s)
BANNER sensor array	<p>Later Casing “E” models. This model includes two top brackets to secure and adjust the BANNER sticks.</p> 	<p>Adjusting the BANNER Sensor Array (Later Model “E” Casings) (page 86)</p> <p>This procedure contains the following sub-procedures:</p> <ul style="list-style-type: none"> • Vertical Adjustment (page 89) • Pivoting the Detection Sticks (Forward/Backward) (page 90) <ul style="list-style-type: none"> — No Adjustment Guide or Custom Carpenter Square Available (page 90) — Custom Carpenter Square Available (page 91) • Pivoting the Detection Sticks (Side to Side) (page 94) <ul style="list-style-type: none"> — No Alignment Tool or Guides Available (page 94) — Laser Alignment Tool (LAT-1) Available (page 96)
BANNER sensor array	<p>Casing “D” and earlier casing “E” models. These models include a single top bracket.</p> 	<p>Adjusting the BANNER Sensor Array (Casing Models “D” and Early “E” Casings) (page 98)</p>

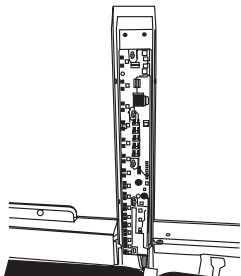
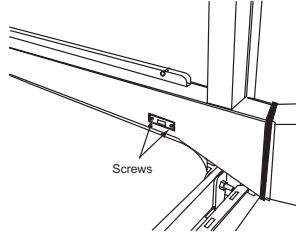
Sensor Type	Casing Model / Description	Procedure(s)
SCANGINEER sensor array	Casing models “C” and earlier. This sensor array consists of two circuit boards.	Adjusting the SCANGINEER Sensor Array (Casing Models “C” and Earlier) (page 101)
		
Take-away belt sensor	Casing “C” and later. This sensor is installed on a square bracket on the skirt.	Adjusting the Take-Away Belt Sensor - Casing Version “C” and Later (page 104)
		
Take-away belt sensor	Casing version “B” and earlier. This sensor is installed directly on the skirt.	Adjusting the Take-Away Belt Sensor - Casing Version “B” and Earlier (page 105)
Collection area sensor	All casing models.	Adjusting the Collection Area Sensor (page 107)

Adjusting the BANNER Sensor Array (Later Model “E” Casings)

This procedure applies to casing models shipped from the U-Scan Assembly facility beginning in October 2006.

Requirements:

- Phillips screwdriver (magnetic tip recommended)
- Two test shims (9000100 and 9000101)
- 11-32 wrench
- 11-32 nut driver
- Custom carpenter square positioner (optional)
- Laser alignment tool (optional - part number LAT-1)

Overview of Adjustment Hardware

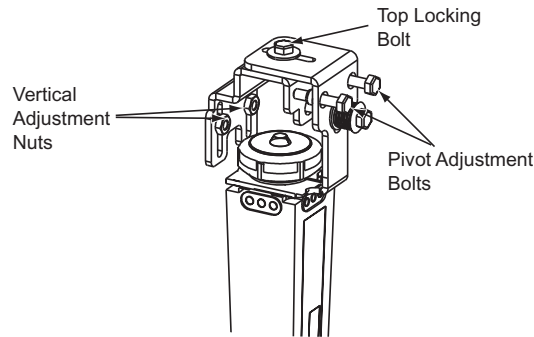

Adjustment Guide:

Tool	Description	Result
9000100 (thinner)	.115 to .122 test shim for gauging vertical position	No Detect
9000101 (thicker)	.175 to .182 test shim for gauging vertical position	Must detect
Custom carpenter square (optional)	Custom-made carpenter square for ensuring BANNER sticks are properly aligned within the sensor housing (front-back position)	Each stick must be parallel to the carpenter square edge to ensure the sticks are parallel.
Laser alignment tool (optional - LAT-1)	Laser tool for ensuring the sensor beam is properly aligned (side to side position).	When the LAT is attached to a stick, the beam must point to the direct center of the opposite stick's lens.

LED Indications

The BANNER sensor array consists of a sensor and an emitter detection stick.

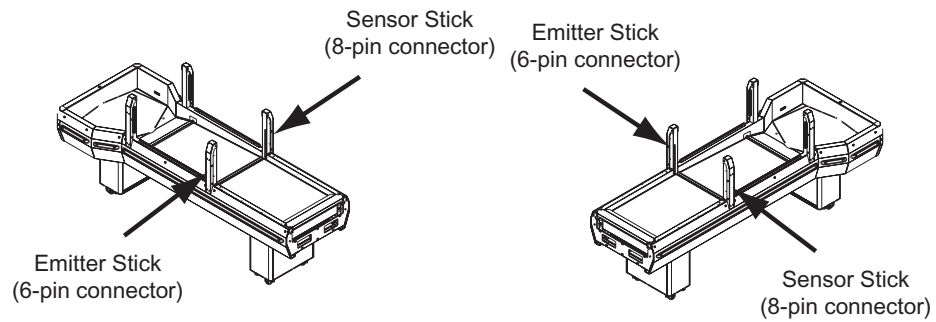

The sensor stick includes three colored indicator LEDs. Refer to the table below for LED indications.

Detection Stick	LED	Function
Emitter	Red	Power on, operation OK
Sensor	Red	Object detected
Sensor	Yellow	<ul style="list-style-type: none">• Sensor not properly aligned• Lens may be dirty• Device may be faulty
Sensor	Green	Alignment of sensor is correct, ready for operation

Access the Adjustment Bolts

For later casing “E” models, remove the screw and lower the cover panel on the sensor faceplate to access the adjustment bolts.

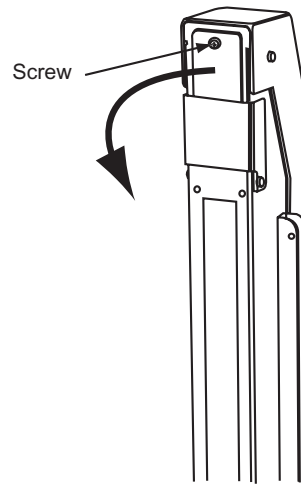

For earlier casing “E” models, follow the steps below:

- a. Remove the Plexiglas guards.

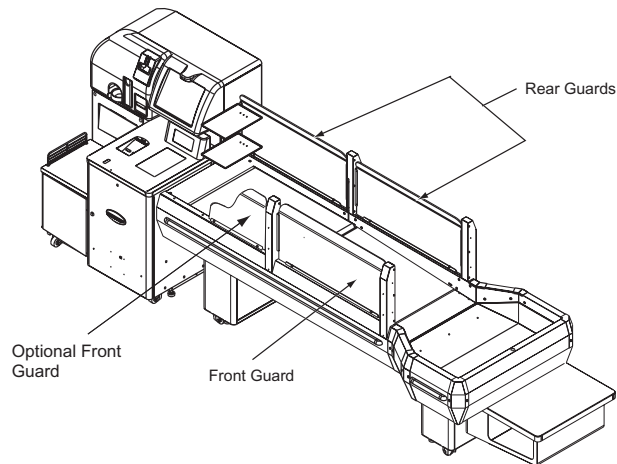

- b. Use a Phillips screwdriver to remove the eight screws securing each sensor faceplate to the sensor housing.

NOTE: *Two of the screws are on the tabs on the sensor faceplate base.*

- c. Remove the sensor faceplates.

Vertical Adjustment

1. Access the adjustment bolts. Refer to “[Access the Adjustment Bolts](#)” on page 88.
2. Use an 11-32 wrench to **slightly** loosen the top locking bolt.

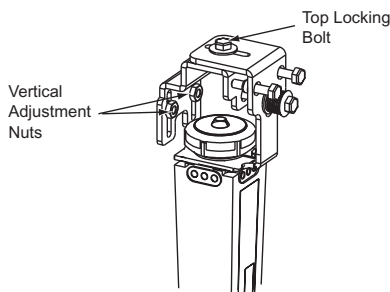

3. Loosen the two 8-32 vertical adjustment nuts (see graphic above) on the back brackets and raise or lower the sticks to achieve the results in the table below in each of the three test positions:

Test Shim(s)	Test Positions	Result
9000100 (thinner)	- Center of belt - 9” left of center - 9” right of center	- No Detect - Sensor stick green LED is on while shim passes through
9000101 (thicker)		- Must detect - Sensor stick red LED comes on when the shims pass through the arch.

4. If the sensors are properly aligned, tighten the top locking bolt.

OR

If the sensors are still not aligned, try pivoting the sensor sticks forward/backward OR left/right in the sensor housing as outlined in the pages that follow.

5. Turn the power switch on the controller board off and then on again to recalibrate the sensor array and reset the sensor gains control.
6. Test the shims (detect / no detect) again while the belt is in motion.
7. Replace the sensor faceplates and Plexiglas.

Pivoting the Detection Sticks (Forward/Backward)

The detection sticks must be perfectly parallel to each other. If you determine that the vertical position of the detection sticks is correct but there is still an issue with the arch alignment, follow one of the procedures below to pivot the detection sticks in the housing.

- [No Adjustment Guide or Custom Carpenter Square Available](#) (page 90)
- [Custom Carpenter Square Available](#) (page 91)
- [Adjustment Guides Available](#) (page 92)

No Adjustment Guide or Custom Carpenter Square Available

1. Access the adjustment bolts. Refer to [“Access the Adjustment Bolts”](#) on page 88.
1. Loosen the top locking bolt.
2. Locate the two pivot adjustment bolts on the front bracket.

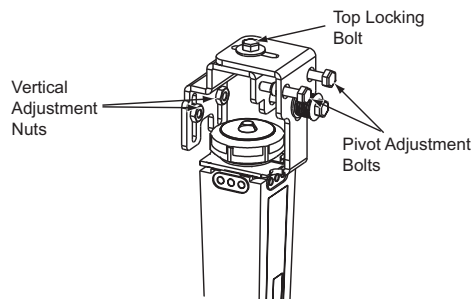

3. Tighten both bolts to pivot the front of the stick forward OR loosen both bolts to pivot the front of the stick back.
4. Alternate between turning the adjustment bolts. For example, turn the left bolt two times, then turn the right bolt two times until the desired position is achieved.
5. Ensure that no object is detected when nothing is present between the sensors.
6. Ensure that the sensor detects the thicker shim.
7. **Tighten the top locking bolt when the sensor is properly aligned.**
8. Turn the power switch on the controller board off and then on again to recalibrate the sensor array and reset the sensor gains control.
9. Test the shims (detect / no detect) again while the belt is in motion.
10. Replace the sensor faceplates and Plexiglas.

Custom Carpenter Square Available

1. Access the adjustment bolts. Refer to “[Access the Adjustment Bolts](#)” on page 88 and follow the steps for removing the faceplates.
2. Set the carpenter square on the belt between the two BANNER sticks. Slide the carpenter square into the sensor housing of the stick you will adjust first.

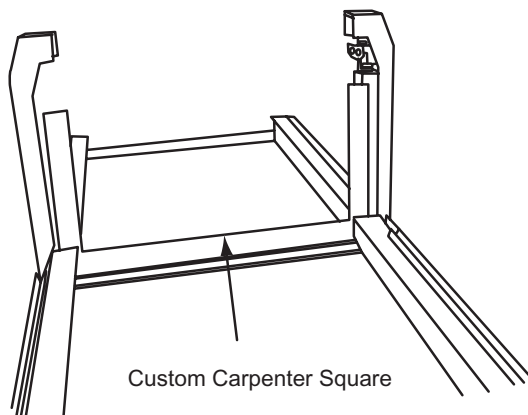

3. Loosen the top locking bolt.
4. Tighten both pivot adjustment bolts to pivot the front of the stick forward OR loosen both bolts to pivot the front of the stick back.

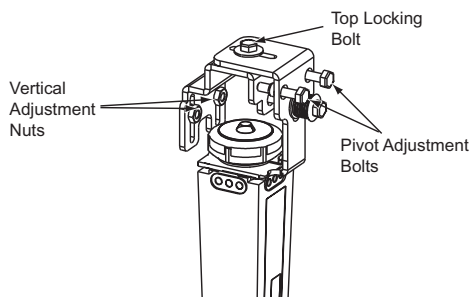

5. Alternate between turning the adjustment bolts. For example, turn the left bolt two times, then turn the right bolt two times until the stick is directly parallel to the carpenter square.
6. When the first stick is properly adjusted, slide the carpenter square into the other sensor housing.
7. Repeat the steps above until the other stick is directly parallel to the carpenter square.
8. **Tighten the top locking bolt when the sensor is properly aligned.**
9. Turn the power switch on the controller board off and then on again to recalibrate the sensor array and reset the sensor gains control.
10. Test the shims (detect / no detect) again while the belt is in motion.
11. Replace the sensor faceplates and Plexiglas.

Adjustment Guides Available

1. Access the adjustment bolts. Refer to “[Access the Adjustment Bolts](#)” on page 88 and follow the steps for removing the faceplates.
2. Slide the cables out of the sensor housings to allow you to position the adjustment guides (11001400).
3. Position an adjustment guide so that the top tab is flush with the bottom of the BANNER mounting bracket and the side tabs are flush against the side of the BANNER stick.

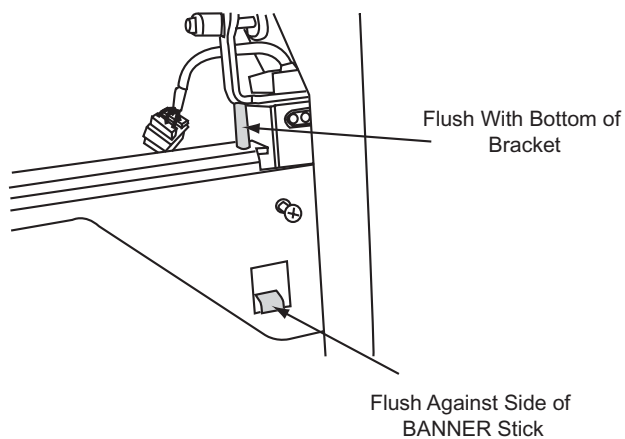

4. **Slightly** tighten the screw on either side of the adjustment guide to secure it.
5. Repeat the steps above to secure the other adjustment guide to the other BANNER stick.
6. Loosen the top locking bolt.
7. Set a ruler or level on top of the guides.

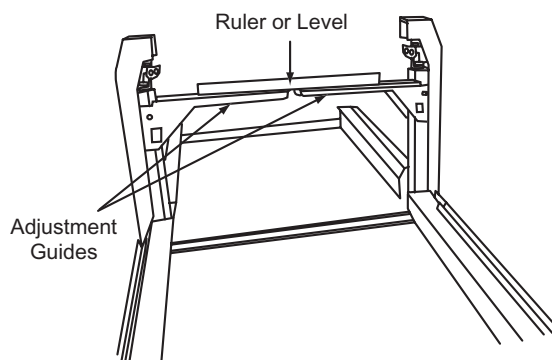

-
8. Tighten both pivot adjustment bolts to pivot the front of the stick forward OR loosen both bolts to pivot the front of the stick back.

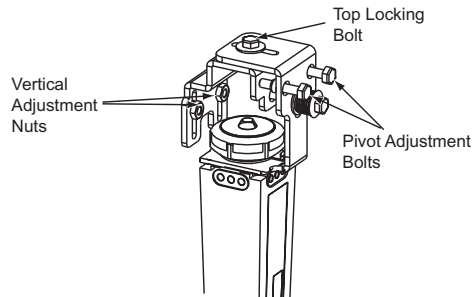

9. Alternate between turning the adjustment bolts. For example, turn the left bolt two times, then turn the right bolt two times until the ruler or level is flat on the two guides.
10. **Tighten the top locking bolt when the ruler or level is perfectly flat.**
11. Turn the power switch on the controller board off and then on again to recalibrate the sensor array and reset the sensor gains control.
12. Test the shims (detect / no detect) again while the belt is in motion.
13. If the arrows on the tips of the arrows on the adjustment guides are not perfectly aligned, refer to [“Adjustment Guides Available”](#) on page 94 to adjust the position further.
14. Replace the sensor faceplates and Plexiglas.

Pivoting the Detection Sticks (Side to Side)

The sensor beams must point directly straight ahead. The emitter stick beam should align with the center of the sensor stick. If there is an issue with the alignment, follow one of the procedures below to adjust the detection sticks:

- [No Alignment Tool or Guides Available](#) (page 94)
- [Adjustment Guides Available](#) (page 94)
- [Laser Alignment Tool \(LAT-1\) Available](#) (page 96)

No Alignment Tool or Guides Available

1. Access the adjustment bolts. Refer to [“Access the Adjustment Bolts”](#) on page 88.
2. Locate the two pivot adjustment screws on the front bracket. (They are the same screws used to pivot the sticks forward and backward.)

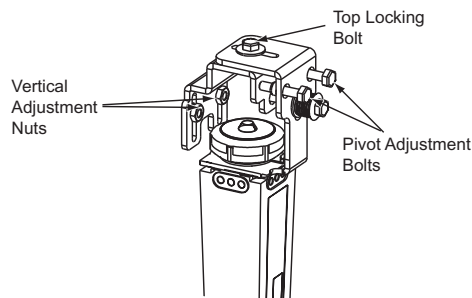

3. Tighten the right adjustment screw to turn the stick slightly clockwise, OR tighten the left adjustment screw to turn the stick slightly counterclockwise.
4. Ensure that no object is detected when none is present between the sensors.
5. **Tighten the top locking bolt when the sensor is properly aligned.**
6. Turn the power switch on the controller board off and then on again to recalibrate the sensor array and reset the sensor gains control.
7. Test the shims (detect / no detect) again while the belt is in motion.
8. Replace the sensor faceplates and Plexiglas.

Adjustment Guides Available

1. Access the adjustment bolts. Refer to [“Access the Adjustment Bolts”](#) on page 88 and follow the steps for removing the faceplates.
2. Slide the cables out of the sensor housings to allow you to position the adjustment guides (11001400).

-
3. Position an adjustment guide so that the top tab is flush with the bottom of the BANNER mounting bracket and the side tabs are flush against the side of the BANNER stick.

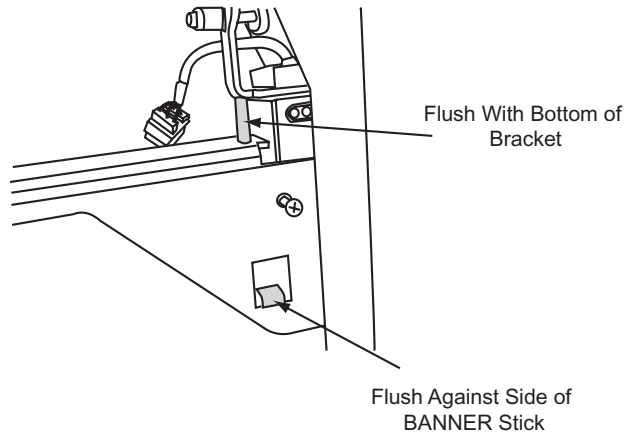

4. **Slightly** tighten the screw on either side of the adjustment guide to secure it.
5. Repeat the steps above to secure the other adjustment guide to the other BANNER stick.
6. Loosen the top locking bolt.
7. Tighten the right adjustment screw to turn the stick slightly clockwise, OR tighten the left adjustment screw to turn the stick slightly counterclockwise until the arrows are perfectly aligned.

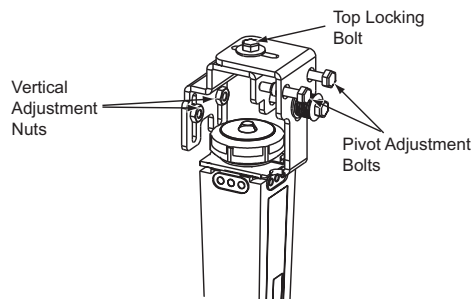

8. Hold a ruler or level against the side of the adjustment guides. Ensure that there are no gaps between the ruler or level and the adjustment guides.

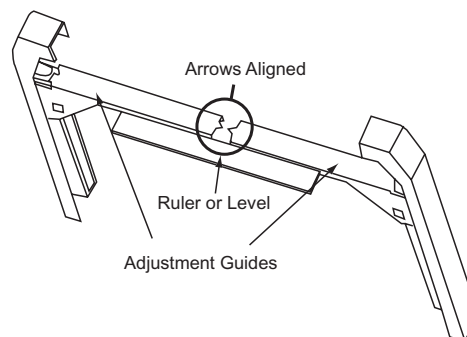

-
9. Adjust the bolt again, if necessary.
 - 10. Tighten the top locking bolt when the arrows are perfectly aligned.**
 11. Turn the power switch on the controller board off and then on again to recalibrate the sensor array and reset the sensor gains control.
 12. Test the shims (detect / no detect) again while the belt is in motion.
 13. Replace the sensor faceplates and Plexiglas.

Laser Alignment Tool (LAT-1) Available

1. Access the adjustment bolts. Refer to [“Access the Adjustment Bolts”](#) on page 88 and follow the steps for removing the faceplates.
2. Attach the laser alignment tool near the top of the sensor. Connect the LAT to the first groove on the sensor.

NOTE: Do *NOT* install the LAT lower than the first groove. This can damage the sensor lens.

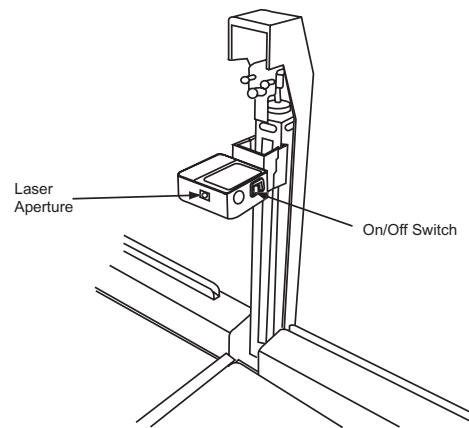

3. Turn on the laser beam.
4. Place a white piece of paper (or one of the test shims) on the opposite BANNER stick to gauge the position of the beam.
5. Locate the two pivot adjustment screws on the front bracket. (They are the same screws used to pivot the sticks forward and backward.)

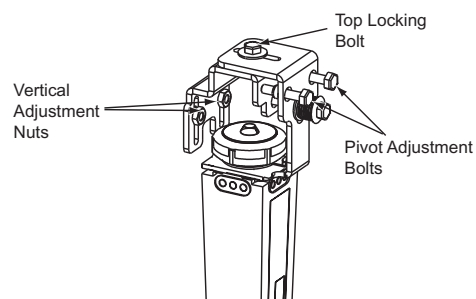

-
6. Tighten the right adjustment screw to turn the stick slightly clockwise, OR tighten the left adjustment screw to the turn the stick slightly counterclockwise.
 7. Adjust the stick until the beam is directly centered on the lens of the opposite BANNER stick.
 - 8. Tighten the top locking bolt when the sensor is properly aligned.**
 9. Turn the power switch on the controller board off and then on again to recalibrate the sensor array and reset the sensor gains control.
 10. Test the shims (detect / no detect) again while the belt is in motion.
 11. Replace the sensor faceplates and Plexiglas.

Adjusting the BANNER Sensor Array (Casing Models “D” and Early “E” Casings)

The adjustment mechanism for the BANNER sensor array in earlier casing “E” models and casing “D” models only allows for vertical adjustment.

1. Remove the Plexiglas guards.

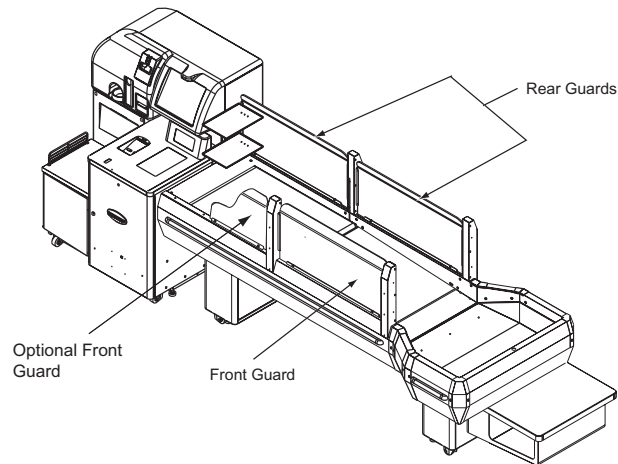

2. Use a Phillips screwdriver to remove the eight screws securing each sensor faceplate to the sensor housing.

NOTE: *Two of the screws are on the tabs on the sensor faceplate base.*

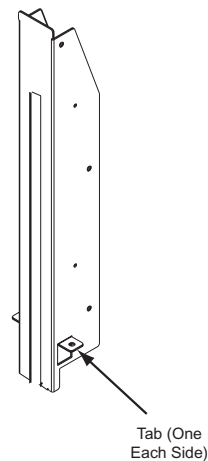

3. Remove the sensor faceplates.

- Loosen the two 8-32 vertical adjustment nuts (see graphic above) on the back brackets and raise or lower the sticks to achieve the results in the table below in each of the three test positions:

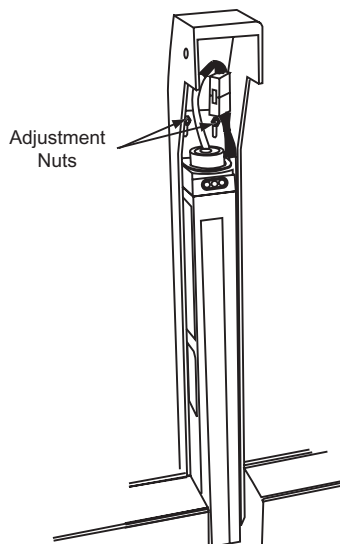

Test Shim(s)	Test Positions	Result
9000100 (thinner)	- Center of belt - 9" left of center - 9" right of center	- No Detect - Sensor stick green LED is on while shim passes through
9000101 (thicker)		- Must detect - Sensor stick red LED comes on when the shims pass through the arch.

- When the sensor is properly adjusted, fully tighten the two adjustment nuts to secure the detection sticks.
- Open the compartment below the input belt and access the controller board.
- Turn on switch A on the controller board to start the input belt.
- Monitor the LEDs on the sensor stick to ensure that the belt is not high enough at any point to interrupt the sensor array beams. The red LED comes on when the sensor is triggered.
- Stop the input belt.
- Turn the power switch on the controller board off and then on again to recalibrate the sensor array and reset the sensor gains control.
- If necessary, adjust the input belt tracking. Refer to [“Adjusting the Belt Tension and Tracking”](#) on page 73.
- Replace the sensor faceplates and Plexiglas guards.

-
13. Test the sensors through the **Device Tester**. Refer to [“Testing the Belt Devices in the Device Tester”](#) on page 36.
 14. Allow the belt to run for approximately 5 minutes to ensure that the sensor is properly adjusted.
 15. Make sure that the message **Trigger Data (1)** does **not** appear in the **Device Tester**.

Adjusting the SCANGINEER Sensor Array (Casing Models “C” and Earlier)

The sensors may not detect certain items if they are not properly adjusted. If the sensors do not detect an item, the take-away belt will not advance. Adjust the sensors if the belts are not advancing at the appropriate time.

Also, if the sensor arrays are positioned too low, they may detect the input belt when it is in motion and result in unnecessary sensor array (arch) violations. To correct this problem, raise the sensor array circuit boards or lower the input belt position.

1. Remove the Sensor Faceplate

Use a Phillips screwdriver to remove the eight screws securing the sensor faceplate to the sensor housing.

NOTE: *Two of the screws are on the tabs on the sensor faceplate base.*

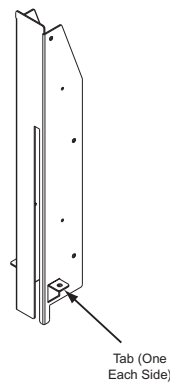

2. Test a 3/16” Object

1. Locate an object measuring 3/16”, such as a CD case. If necessary, you can create an object by taping together several washers.
2. Place the item on the belt in front of the sensors.
3. Loosen the two upper adjustment screws in each sensor arm.

CAUTION: Be careful when moving the circuit board. It is easy to cause a short circuit on the board.

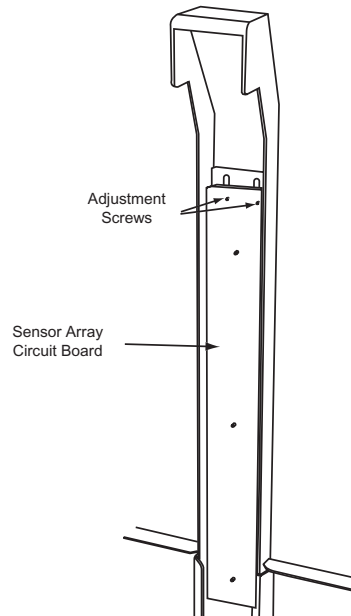

4. Raise both circuit boards until the sensor does **not** detect the item. (One of the orange LEDs on the circuit board turns off when nothing is detected.)

NOTE: *The Receiver and Transmitter circuit boards should be at the same level.*

5. Slightly lower the circuit boards until the sensor beam detects the item and the light on the circuit board turns orange.
6. Move the item over 1/2" and ensure that the sensors still detect the item.
7. Repeat step 6 to test the sensors in all positions on the belt (i.e. the full length of the sensor beam).
8. Remove the item from the belt.

3. Test a 1/8" Object

1. Locate an item measuring 1/8" in height. If necessary, you can create an object by taping together several washers.
2. Place the item on the belt in front of the sensors. Make sure that the sensors do **NOT** detect the item.
3. Adjust the height of the circuit boards if necessary.
4. Repeat the test procedure to ensure that the 1/8" item is **NOT** detected at all positions on the belt.

NOTE: *It is very difficult to adjust the sensors so that the 1/8" item is not detected at all positions along the length of the sensor beam. It is acceptable if the item is detected in only one or two locations along the beam.*

4. Recalibrate the Sensor Array

1. Inside the Customer Station casing, locate the sensor array power supply (cable “X”).
2. Disconnect and then reconnect the cable X to recalibrate the sensors.

5. Perform a Final Test

1. Repeat the test procedure to ensure that an item measuring 3/16” is detected in all positions.
2. Tighten the two adjustment screws to secure the circuit board.
3. Open the compartment below the input belt and access the controller board.
4. Turn on switch A on the controller board to start the input belt.
5. Monitor the light on the circuit board to ensure that the belt is not high enough at any point to interrupt the sensor array beams. The orange LED turns on when the sensor is triggered.
6. Stop the input belt.
7. If necessary, adjust the input belt to lower it. Refer to [“Adjusting the Belt Tension and Tracking”](#) on page 73.
8. Replace the sensor faceplates.
9. Test the sensors through the **Device Tester**. Refer to [“Testing the Belt Devices in the Device Tester”](#) on page 36.
10. Allow the belt to run for approximately 5 minutes to ensure that the sensor is properly adjusted.
11. Make sure that the message **Trigger Data (1)** does **not** appear in the **Device Tester**.

Adjusting the Take-Away Belt Sensor - Casing Version “C” and Later

1. Remove the two screws securing the take-away belt sensor bracket to the casing.

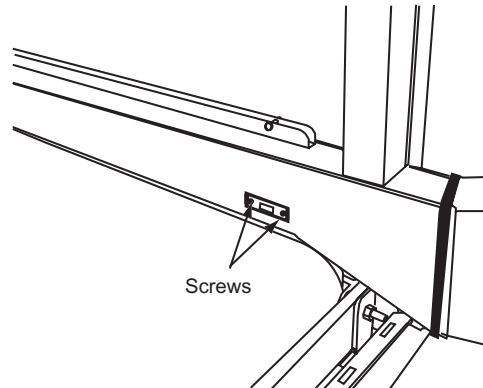

2. Gently pull the sensor bracket towards you.
3. Hold the sensor bracket in the position in which the sensor is installed.
4. Hold a white sheet of paper in front of the sensor to view the sensor beam.
5. Loosen the two screws securing the sensor to the bracket.
6. Pivot the sensor until the beam points in a straight line toward the reflector on the side of the casing.
7. Tighten the two screws to secure the sensor in the proper position.
8. Align the sensor bracket in the casing.
9. Fasten the two screws to secure the sensor bracket to the casing.
10. Access the controller board.
11. Ensure that LED “M” is **NOT** on.
12. If the LED is on, repeat the steps above to further adjust the sensor beam position.

Adjusting the Take-Away Belt Sensor - Casing Version “B” and Earlier

1. Access the Take-Away Belt Sensor

1. Remove the screws securing the sensor array faceplate on the sensor side of the casing. Do **NOT** forget the screws on the tabs at the base of the faceplate.

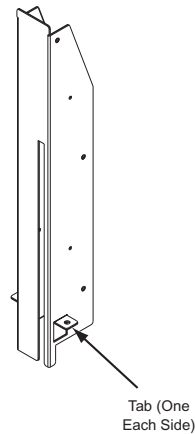

2. Remove the screws securing the inner skirt on the sensor side of the casing.
3. Lift and remove the inner skirt. If necessary, disconnect the take-away belt sensor cable (cable “Y”).
4. Remove the two screws securing the sensor bracket to the skirt.
5. If necessary, reconnect cable “Y.”

2. Adjust the Sensor

1. Hold the sensor bracket in the position in which the sensor is installed.
2. Hold a white sheet of paper in front of the sensor to view the sensor beam.
3. Loosen the two screws securing the sensor to the bracket.
4. Pivot the sensor until the beam points in a straight line toward the reflector on the side of the casing.
5. Tighten the two screws to secure the sensor in the proper position.

3. Replace the Sensor

1. From the back side of the inner skirt, replace the two screws to secure the sensor bracket to the skirt.
2. Replace the inner skirt on the unit.

4. Test the Sensor

1. Access the controller board.
2. Ensure that LED “M” is NOT on.

NOTE: *If LED “M” is on, first try pushing the skirt further back onto the side of the conveyor. If that does not work, place a white paper in front of the beam to gauge where the beam is pointing. Repeat the steps in [“Adjust the Sensor”](#) on page 105 to adjust the sensor position further.*

3. Replace the screws securing the inner skirt to the casing.
4. On the controller board, turn on switch C to run the take-away belt. Allow the belt to run for approximately 5 minutes to ensure that the sensor is properly adjusted.
5. Monitor LED “M” on the controller board to ensure that the belt does not break the sensor beam. If the belt breaks the beam, refer to [“Adjusting the Belt Height”](#) on page 82 to lower the belt.

Adjusting the Collection Area Sensor

1. Remove the two screws securing the collection area sensor bracket to the casing.

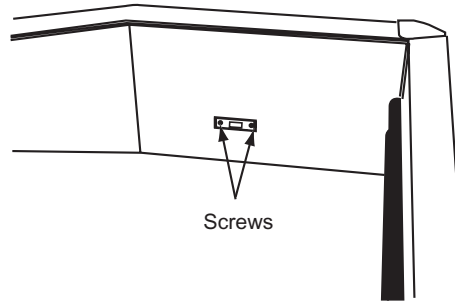

2. Gently pull the sensor bracket towards you.
3. Hold the sensor bracket in the position in which the sensor is installed.
4. Hold a white sheet of paper in front of the sensor to view the sensor beam.
5. Loosen the two screws securing the sensor to the bracket.
6. Pivot the sensor until the beam points in a straight line toward the reflector on the side of the casing.
7. Tighten the two screws to secure the sensor in the proper position.
8. Align the sensor bracket in the casing.
9. Fasten the two screws to secure the sensor bracket to the casing.
10. Access the controller board.
11. Ensure that LED "L" is **NOT** on.
12. If the LED is on, repeat the steps above to further adjust the sensor beam position.

U-Scan Max Component Replacement

This chapter presents the following information:

- [Replacing the Sensors](#) (page 111)
- [Replacing the Controller Board Fuse](#) (page 144)
- [Accessing the Belt Components](#) (page 127)
- [Replacing the Controller Board](#) (page 145)
- [Replacing the Belt Components](#) (page 134)
- [Crimping the Cables](#) (page 148)
- [Replacing a Belt Scale Load Cell](#) (page 140)
- [Replacing the SCANGINEER Sensor Array Wires in the Cable Connection Head](#) (page 153)
- [Replacing the SCALETRON CPU \(Scale Brain\)](#) (page 143)

Required Tools

You may need the following tools while servicing the U-Scan Max Single Belt:

- Ratchet set (7/16, 5/16 sockets)
- Nut driver
- Drill with screwdriver and drill bits (recommended)
- Magnetic tip Phillips screwdriver / screwdriver set
- Flat-head screwdriver
- Tie-wraps
- Wall mounts
- Allen keys
- Adjustable wrench / wrench set
- Carpenter's level
- Carpenter's square
- Extra pan head 8-32 x 3/4 Phillips screws
- Klein tools Cat. no. 1000 crimping for stripping wires and crimping the ground cables

-
- AMP tools (for crimping all other cables):
 - Open barrel crimp tool (300-009)
 - 3-pos female body (cap) connector (1-480701-0)
 - 3-pos male body (plug) connector (1-480700-0)
 - Package of 10 male crimp pins (350547-1)
 - Package of 10 female crimp sockets (350550-1)
 - UNI-MATE II extraction tool (318851-1)

Replacing the Sensors

Replacing the BANNER Sensor Arrays (Later Casing Version "E")

Requirements:

- Two test shims (9000100 and 9000101 - Engineering drawings included at end of document)
- 5/16 wrench
- 11-32 nut driver
- T-20 TORX screwdriver
- Flat-head screwdriver
- Replacement BANNER sensor (90001536) or emitter (90001536) stick

Overview of Replacement

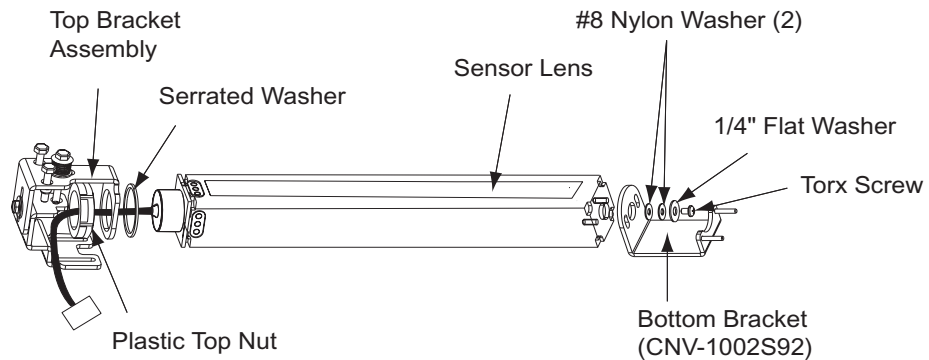

1. Shut Down the U-Scan Max Single Station

1. Unlock and open the bottom compartment.
2. Turn off the power switch on the controller board.

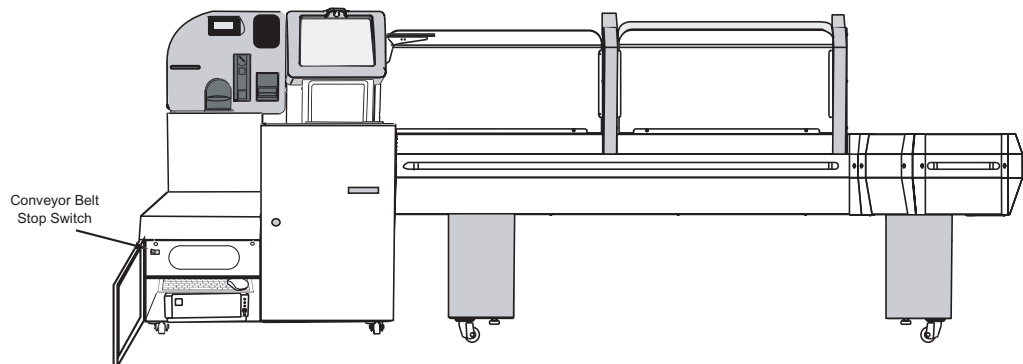

2. Remove the Faulty BANNER Stick

NOTE: Set all hardware (brackets and fasteners) aside to be re-used when you install the new BANNER stick.

1. Remove the Plexiglas guards.
2. Remove the sensor faceplate(s).
3. Disconnect the sensor array cable (MOLEX-type connector).
4. Use an 11-32 nut driver to remove the two 8-32 nuts on the back bracket.
5. Carefully lift and remove the stick and brackets from the sensor arm.
6. Remove the front screw, and compression spring, and two flat washers from the front bracket.
7. Unscrew the plastic top nut from the BANNER stick.
8. Remove the serrated washer from the BANNER stick.
9. Use a T-20 Torx screwdriver to remove the single screw and washers securing the bottom bracket to the bottom of the BANNER stick.
10. Remove the bottom bracket.

3. Install the Replacement BANNER Stick

1. Locate the replacement BANNER stick. Ensure that you have the proper stick (sensor or emitter) based on the sensor housing in which it was installed or the number of pins on the connector.

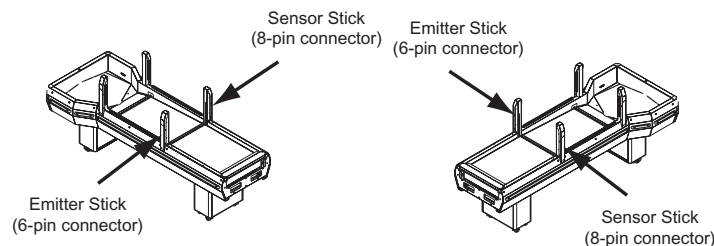

2. Use a T-20 Torx screwdriver to remove the screw from the bottom of the new BANNER stick.
3. Position the bottom bracket (CNV-1002S92) on the bottom of the BANNER stick. Ensure that the curved top of the bracket is facing the same direction as the sensor lens, as shown below.

-
4. Thread a 1/4-20 flat washer and two #8 nylon washers (11001719) onto the Torx screw you removed from the bottom of the BANNER stick.

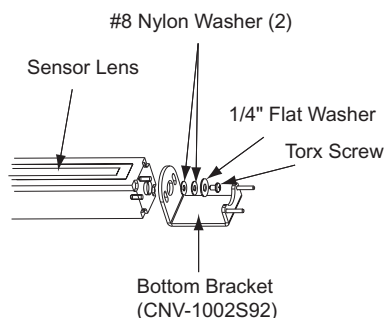

NOTES: Do **NOT** use LOCTITE on the screw, because it can erode the inside of the BANNER stick over time.

All washers must be in place or you will not be able to the adjust the sensor array properly.

5. Fasten the screw to secure the bottom bracket to the BANNER stick until the screw is snug, and then torque it 1/4 of a turn further.
6. Thread the serrated washer onto the cable connector and BANNER stick.

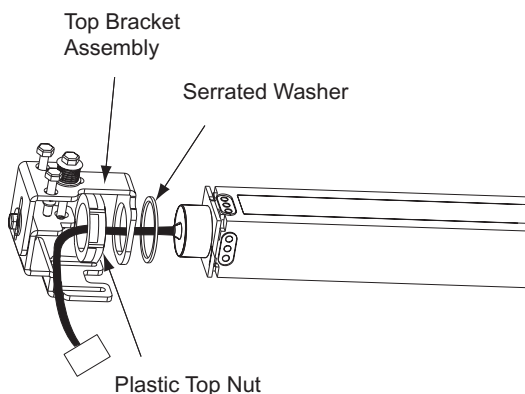

7. Thread the cable connector through the top bracket assembly as shown above. Ensure that BANNER sensor lens is facing front.
8. Thread the cable connector through plastic top nut. Tighten the plastic top nut to secure the BANNER stick to the top bracket assembly.
9. Position the BANNER stick in the casing so that the sensor lens is facing out.
10. Align the slots on the back of the top bracket assembly with the studs in the sensor housing.
11. Raise the BANNER stick so that the bottom of the yellow triangle is above the belt.

NOTE: *The yellow triangle marks the start of the sensor beam. It is meant only as a guideline and the height of the stick may need to be adjusted further.*

12. Fasten an 8-32 Keps nut on each stud to secure the stick inside the sensor housing.

13. Connect the BANNER cable.

14. Use a flat-head screwdriver to push the cable into the sensor housing alongside the BANNER stick.

4. Adjust the BANNER Sensor Array

1. Press the power switch on the controller board panel.

2. Refer to the instructions in [“Adjusting the BANNER Sensor Array \(Later Model “E” Casings\)”](#) on page 86.

Replacing the BANNER Sensor Arrays (Casing Version “D” and Early Casing Version “E”)

Ensure that the sensors are properly adjusted and that the belt position does not affect the sensors before you perform this procedure. Refer to [“Adjusting the BANNER Sensor Array \(Casing Models “D” and Early “E” Casings\)”](#) on page 98 or [“Adjusting the Belt Tension and Tracking”](#) on page 73. If the issue is not resolved, follow these steps to replace the sensor array.

Remove the Detection Stick

1. Turn off the power switch on the controller board panel.
2. Remove the Plexiglas guards.
3. Remove the sensor faceplates.
4. Disconnect the cable connector on the BANNER stick you will replace.
5. Move the cable out of the sensor housing so that it is out of the way.
6. Unscrew the plastic cap that secures the stick to the top bracket.

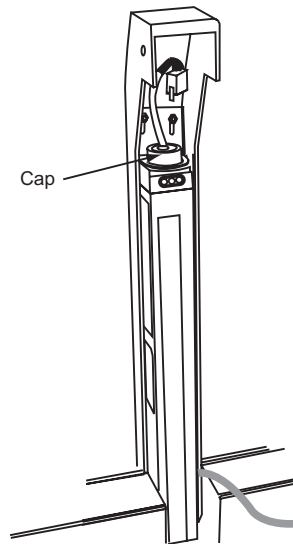

7. Lower the stick as far as possible into the casing.
8. Route the cable down through the bracket.
9. Pivot the stick towards you, then slide it up to remove it from the casing.
10. Use a Phillips screwdriver to remove the two M4 screws securing the bottom bracket to the stick. Set aside the screws and bracket to install on the new detection stick.



Install the Detection Stick

1. Secure the bottom bracket to the new stick with the two short M4 screws.



2. Slide the bottom of the stick into the sensor housing. Ensure that the two studs on the bottom bracket slide into the holes in the bottom of the sensor housing.
3. Route the cable through the hole on the top bracket.

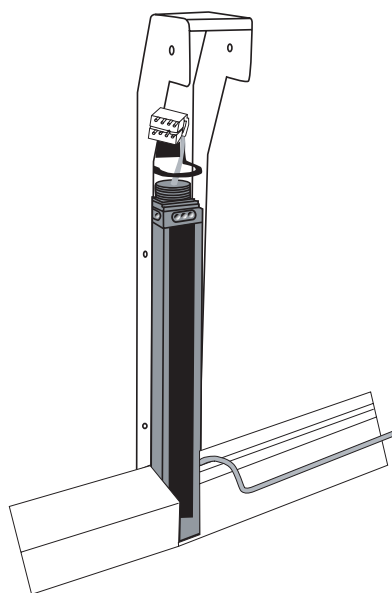

4. Slide the emitter stick up and through the hole on the top bracket.
5. Thread the cable connector through the plastic nut.
6. Tighten the top cap to fasten the stick to the top bracket. Ensure that the stick is facing **DIRECTLY** forward.
7. Ensure that the white line on the stick is above the belt. The white light marks the point at which the sensor beam begins.
8. Locate the cable from the main unit.
9. Route the cable into the sensor arm beside the emitter stick.
10. Connect the cables.
11. Test the sensor array. Refer to [“Test the Sensors”](#) on page 57.
12. If necessary, adjust the sensor array. Refer to [“Adjusting the BANNER Sensor Array \(Casing Models “D” and Early “E” Casings\)”](#) on page 98.

-
- 13.** Re-install the sensor faceplates.
 - 14.** Replace the Plexiglas guards.

Replacing the SCANGINEER Sensor Arrays (Casing Version “C” and Earlier)

Ensure that the sensors are properly adjusted and that the belt position does not affect the sensors before you perform this procedure. Refer to [“Adjusting the SCANGINEER Sensor Array \(Casing Models “C” and Earlier\)”](#) on page 101 or [“Adjusting the Belt Tension and Tracking”](#) on page 73. If the issue is not resolved, follow these steps to replace the sensor array.

Replacing the Receiver Circuit Board

The receiver circuit board is always installed on the same side of the conveyor unit as the cable harness.

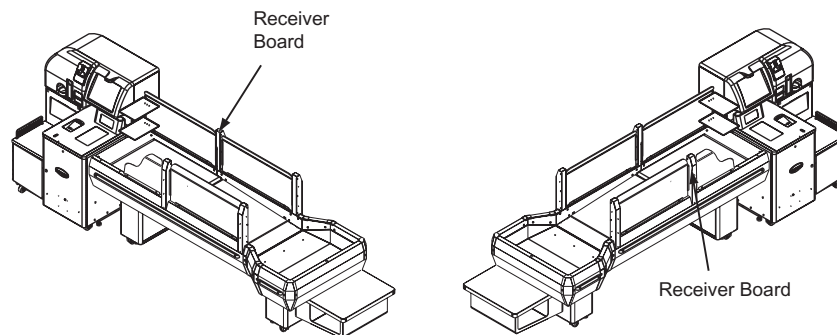

1. **Disconnect the sensor array power cable (cable X - inside the casing) from the power supply adapter. The power must ALWAYS be off when you replace or remove the sensor array circuit boards.**
2. Use a Phillips screwdriver to remove the eight screws securing the sensor faceplate to the sensor housing. Do **NOT** forget the screws on the tabs at the base of the faceplate.

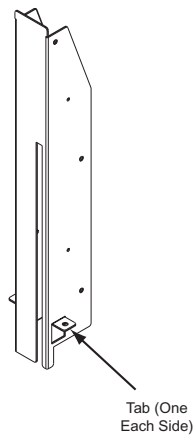

-
3. Locate the three screws that secure the circuit board to the adapter plate.

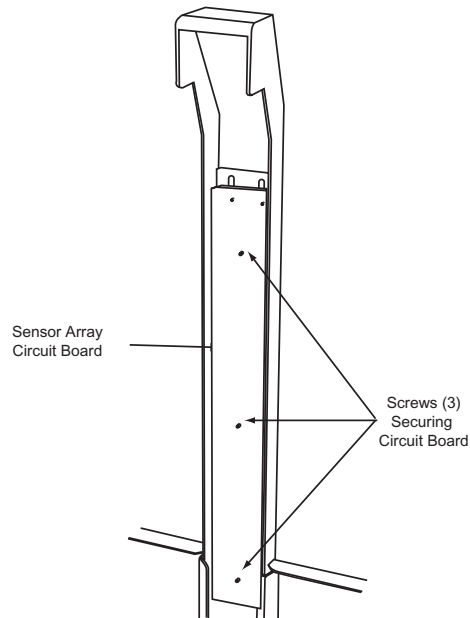

4. Hold the circuit board and remove the screws.
5. Disconnect the three cables from the back of the circuit board.
6. Locate the new Receiver circuit board. The board is labeled “Receiver” on the front.
7. Ensure that all DIP switches on the sensor array circuit board are set to OFF.
8. Ensure that one jumper is in place beside the cable connectors.
9. Connect the cables to the back of the circuit board:
 - a. Connect the 5-pin RS-232 cable with the flat black connector to the top port. Make sure that the closed edge of the connector head is facing out. Make sure that the white wire is in pin 1, and the green wire is in pin 5.

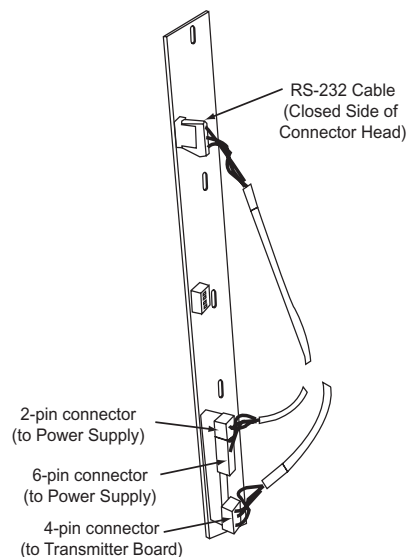

-
- b. Connect the 2-pin green Phoenix connector head to the port labeled “DOUT.” Make sure that the red wire is in pin 1, and the green wire is in pin 2.
 - c. Connect the 6-pin green Phoenix connector head to the first “CAN” port. Make sure that the white wire is in pin 1, and the black wire is in pin 3.
 - d. Connect the 4-pin green Phoenix cable to the port labeled “TRANS.” Make sure that the white wire is in pin 1, and the yellow wire is in pin 4.
10. Place an object measuring 3/16” in height (such as a CD case) on the belt and slide it into the sensor arm to gauge the position to install the sensor circuit board.
 11. Align the holes on the sensor circuit board with the stand-offs inside the sensor housing. Make sure that the bottom of the circuit board is resting on the object measuring 3/16”.
 12. Replace the three screws you removed from the stand-offs to secure the circuit board.
 13. Remove the object.
 14. Reconnect the sensor array power cable.
 15. Adjust and test the sensors to ensure that they are properly aligned. Refer to [“Adjusting the SCANGINEER Sensor Array \(Casing Models “C” and Earlier\)”](#) on page 101.
 16. Replace the sensor faceplate.

Replacing the Transmitter Circuit Board

The transmitter circuit board is always installed on the side of the conveyor unit shown below:

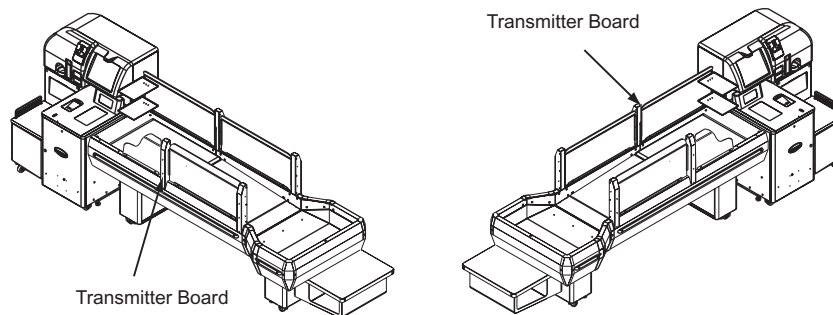

1. **Disconnect the sensor array power cable (cable X - inside the casing) from the power supply adapter. The power must ALWAYS be off when you replace or remove the sensor array circuit boards.**

-
2. Use a Phillips screwdriver to remove the eight screws securing the sensor faceplate to the sensor housing. Do **NOT** forget the screws on the tabs at the base of the faceplate.

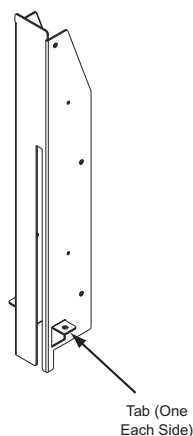

3. Locate the three screws that secure the circuit board.

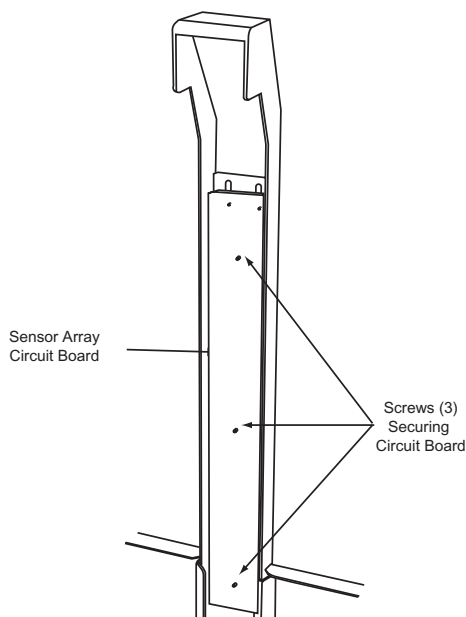

4. Hold the circuit board and remove the screws.
5. Disconnect the cable from the back of the circuit board.
6. Connect the cable to the new circuit board.
7. Place an object measuring $3/16$ " in height (such as a CD case) on the belt and slide it into the sensor arm to gauge the position to install the sensor circuit board.
8. Align the holes on the sensor circuit board with the stand-offs inside the sensor housing. Make sure that the bottom of the circuit board is resting on the object measuring $3/16$ ".
9. Replace the three screws you removed earlier to secure the circuit board.
10. Remove the object.

-
11. Adjust the sensors to ensure that they are properly aligned. Refer to “[Adjusting the SCANGINEER Sensor Array \(Casing Models “C” and Earlier\)](#)” on page 101.
 12. When the sensor is properly adjusted, replace the sensor faceplate.

Replacing the Take-Away Belt Sensor (Casing Versions “C” and Later)

1. Disconnect the controller board power cable.

OR

Turn off the **Power** switch on the controller board panel, if available.

2. Remove the two screws securing the take-away belt sensor bracket to the casing.

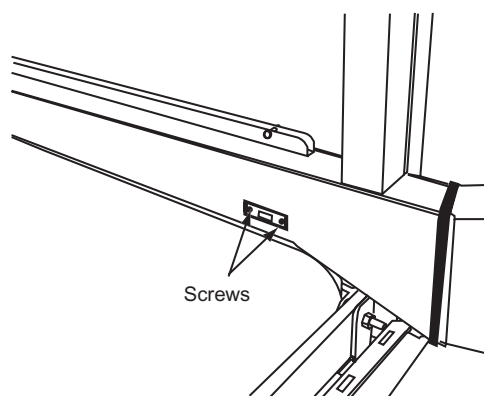

3. Gently pull the sensor bracket towards you.
4. Pull the take-away belt sensor (cable “Y”) out through the cut-out and disconnect the cable.
5. Remove the two screws securing the sensor to the sensor bracket. Set aside.
6. Locate the new sensor.
7. Fasten the two 4-40 x 1/4 screws to install the new sensor on the sensor bracket.
8. Connect the sensor cable to cable “Y” from the cable harness.

-
9. Align the sensor bracket with the rectangular cut-out beside the take-away belt. Ensure that the top piece of the sensor bracket is facing up.

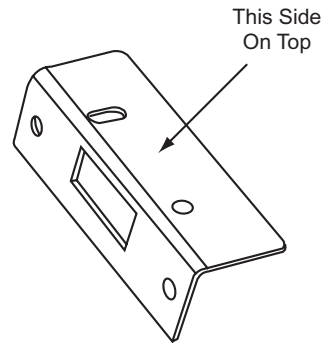

10. Fasten the two 8-32 screws to secure the sensor bracket to the casing.
11. Test the sensor. Refer to [“Test the Sensors”](#) on page 57.
12. If necessary, adjust the sensor. Refer to [“Adjusting the Take-Away Belt Sensor - Casing Version “C” and Later”](#) on page 104.

Replacing the Take-Away Belt Sensor (Casing Versions “B” and Earlier)

Before you perform this procedure, ensure that the sensor is properly aligned and that the take-away belt is not interfering with the sensor. Refer to [“Adjusting the Take-Away Belt Sensor - Casing Version “B” and Earlier”](#) on page 105 or [“Adjusting the Belt Tension and Tracking”](#) on page 73. If the issue persists, follow these steps to replace the take-away belt sensor.

1. Remove the Take-Away Belt Sensor

1. Disconnect the controller board power cable.

OR

Turn off the **Power** switch on the controller board panel, if available.

2. Remove the screws securing the sensor array faceplate on the sensor side of the casing. Do **NOT** forget the screws on the tabs at the base of the faceplate.

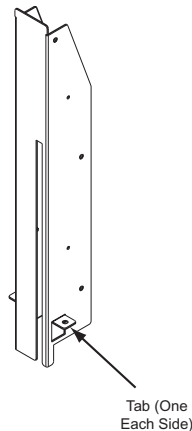

3. Lift and remove the end-access tray.
4. Remove the screws securing the inner skirt on the sensor side of the casing.
5. Lift and remove the inner skirt.
6. Disconnect the take-away belt sensor cable (cable “Y”).

NOTE: *On later systems, you do not need to remove the skirt. Remove only the two screws securing the sensor bracket to the skirt.*

7. Remove the two screws securing the sensor bracket to the skirt. Set aside.
8. Remove the two screws securing the sensor to the sensor bracket. Set aside.

2. Replace the Take-Away Belt Sensor

1. Align the sensor with the square cut-out on the front of the sensor bracket.

-
2. From the top of the sensor bracket, fasten the two 4-40 x 1/4 screws to secure the sensor to the sensor bracket.
 3. Align the sensor bracket with the rectangular cut-out on the side of the take-away belt skirt. Ensure that the top piece of the sensor bracket is facing up.

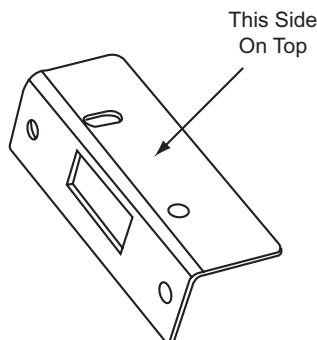

4. Fasten two 8-32 screws to secure the sensor bracket to the casing.
5. Connect the take-away belt sensor cable to cable "Y" from the cable harness inside the casing.
6. Replace the skirt on the casing.
7. Replace the end-access tray.
8. Turn on the **Power** switch on the controller board panel or reconnect the controller board power cable.
9. Test the sensor. Refer to "[Test the Sensors](#)" on page 57.
10. If the sensor needs to be adjusted, refer to "[Adjusting the Take-Away Belt Sensor - Casing Version "B" and Earlier](#)" on page 105.

Replacing the Collection Area Sensor

1. Disconnect the controller board power cable.
OR
Turn off the **Power** switch on the controller board panel, if available.
2. Remove the two screws securing the collection area sensor bracket to the casing.

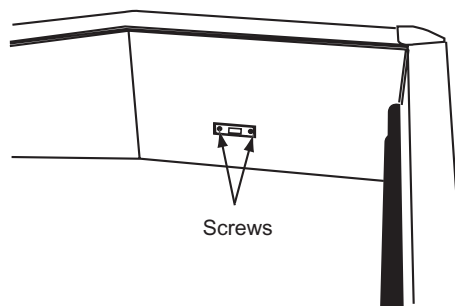

-
3. Gently pull the sensor bracket towards you.
 4. Pull the collection area sensor (cable “Z”) out through the cut-out and disconnect the cable.
 5. Remove the two screws securing the sensor to the sensor bracket. Set aside.
 6. Locate the new sensor.
 7. Fasten the two 4-40 x 1/4 screws to install the new sensor on the sensor bracket.
 8. Connect the sensor cable to cable “Z” from the cable harness.
 9. Align the sensor bracket with the rectangular cut-out on the side of the collection area. Ensure that the top piece of the sensor bracket is facing up.

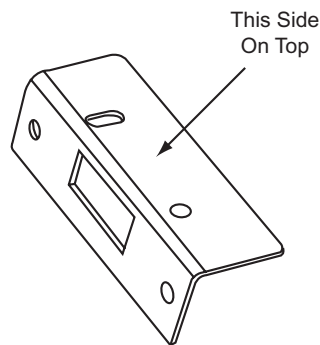

10. Fasten the two 8-32 screws to secure the sensor bracket to the casing.
11. Test the sensor. Refer to [“Test the Sensors”](#) on page 57.
12. If necessary, adjust the sensor. Refer to [“Adjusting the Collection Area Sensor”](#) on page 107.

Accessing the Belt Components

NOTE: *Field engineers do not need to replace the whole belt module, only the components.*

Main Belt Frame Components

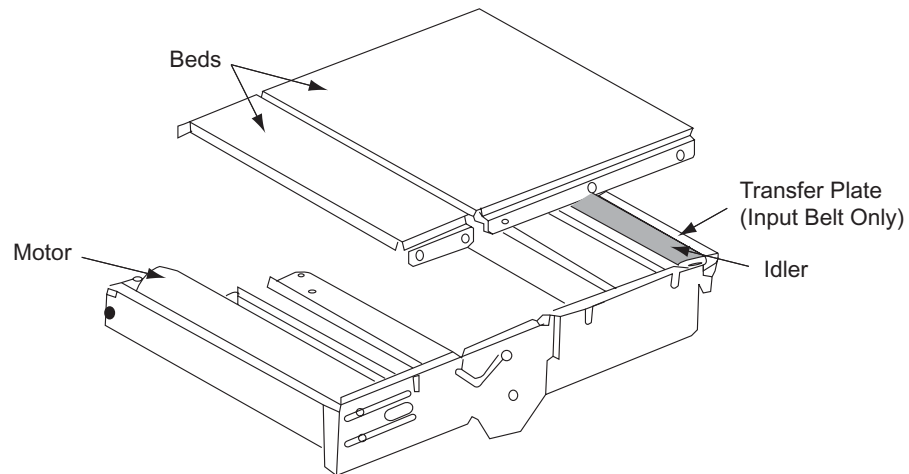

1. Remove the Front and Rear Guards

Remove the front and rear guards **beside the belt you will adjust**.

1. If applicable, locate the two screws securing the front Plexiglas piece to the metal tracks on the skirt.

NOTE: *Some stores have an additional front Plexiglas piece installed as shown below.*

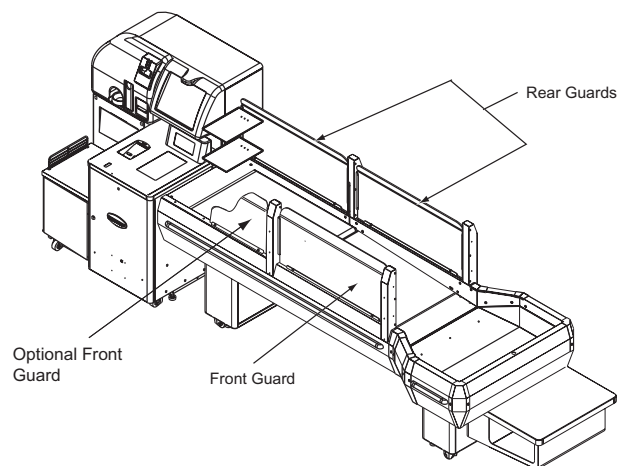

2. Remove the screws.
3. Lift the Plexiglas up and out of the tracks.
4. Repeat the steps above for the rear guard beside the belt you will adjust.

2. Remove the Sensor Faceplates

Use a Phillips screwdriver to remove the eight screws securing the sensor faceplate to the sensor housing.

NOTE: *Two of the screws are on the tabs on the sensor faceplate base.*

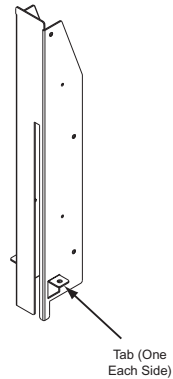

3. Remove the Front Guard Plate or End-Access Plate

If you are replacing the input belt:

1. Remove the four screws securing the front guard plate.

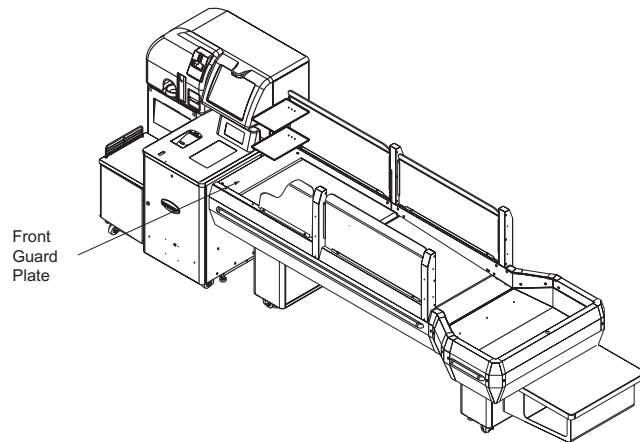

2. Remove the front guard plate.

If you are replacing the take-away belt:

1. For casing version “E” and later, lift and remove the collection area plate.

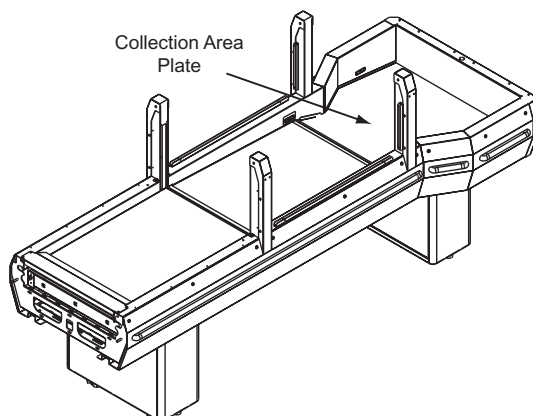

2. Lift and remove the end-access plate.

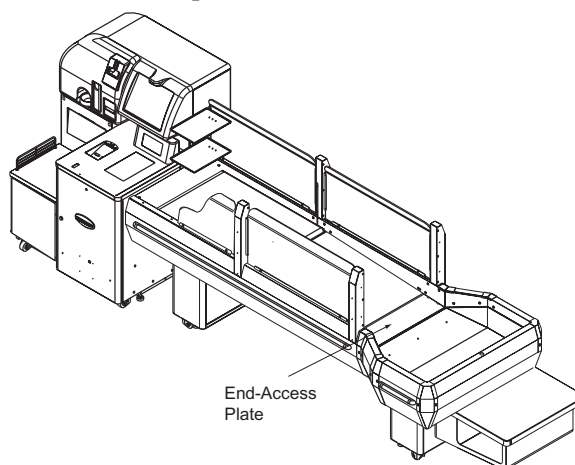

4. Remove the Front and Rear Skirts

1. Locate the screws securing the front skirt beside the belt you will adjust.

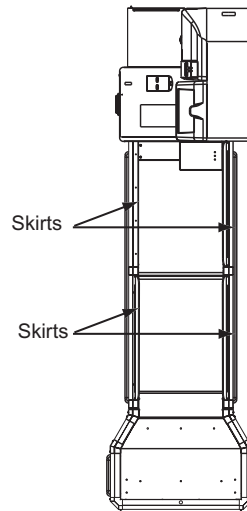

2. Remove the screws.
3. Lift the skirt off the unit. **Do NOT hit the sensor array circuit boards with the skirt.**
4. Repeat the steps above for the rear skirt beside the belt you will adjust.

5. Disconnect the Belt Motor Cable (If Replacing Motor)

If you are replacing the input belt:

1. Remove the screws securing the cover on the sensor pillar below the input belt.
2. Locate the input belt motor cable (cable "V") inside the sensor pillar.
3. Disconnect cable "V."
4. Cut the tie-wraps securing the cables in the pedestal to allow you to raise the belt.

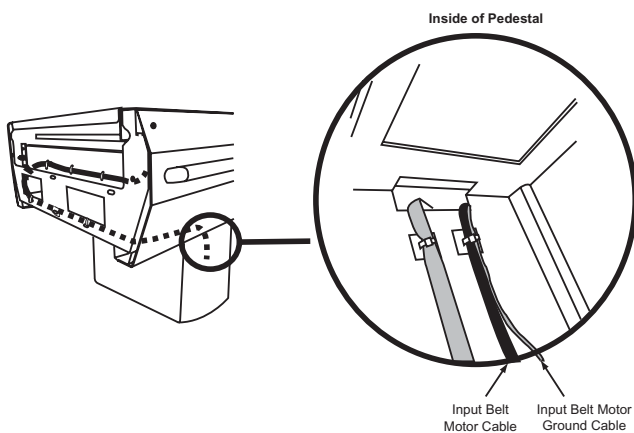

-
5. Cut the tie-wraps securing the input belt motor cable to the belt frame and conveyor unit casing.

NOTE: *Ensure that the heads of the tie-wraps are facing the inside of the conveyor unit.*

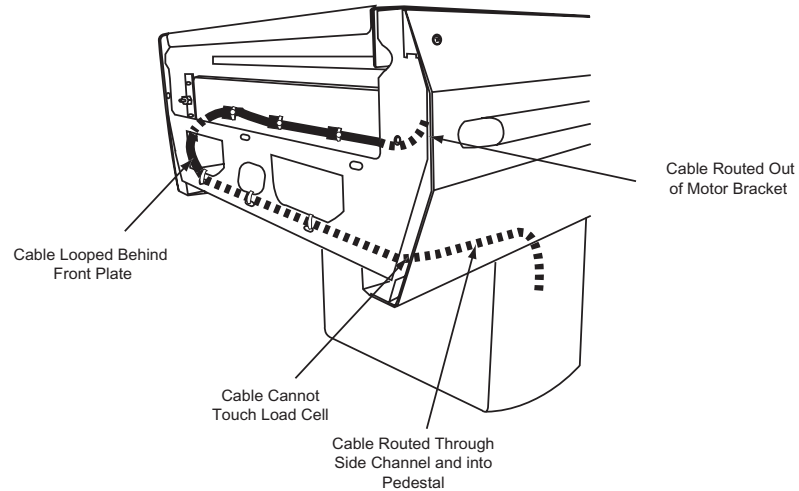

If you are replacing the take-away belt:

1. Locate the take-away belt motor cable (cable “W”) under the collection area. (Reach through the cable access hole to the collection area to locate cable “W.”)

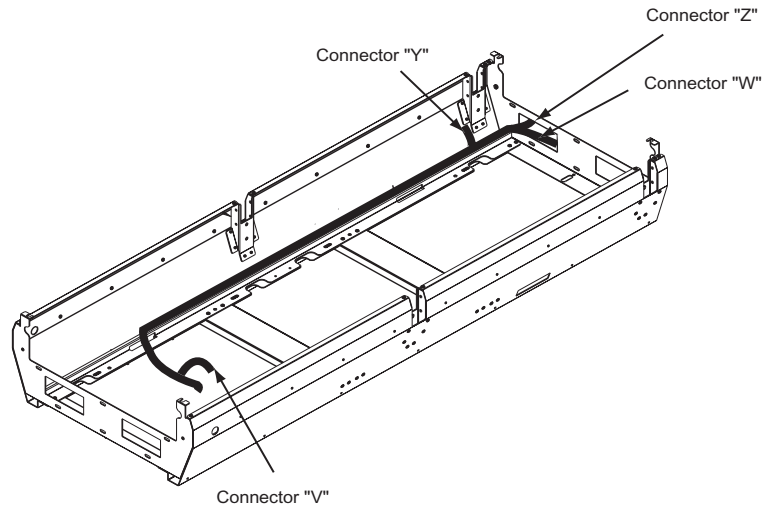

2. Disconnect cable “W.”

6. Remove the Top Nuts

A nut on each side of the belt frame locks the belt into the proper position for operation. Remove both nuts before you raise an end of the belt to service the components.

Use a box wrench (7/16 socket) or an adjustable wrench to remove the top nut on each side of the frame.

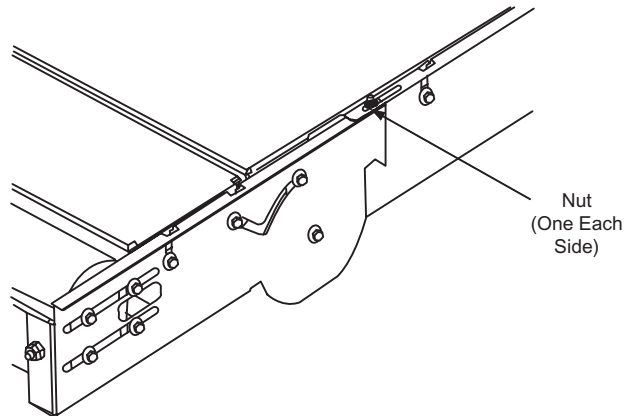

7. Remove the Nuts or Bolts Securing One Side of the Frame

The input belt is secured to a bottom plate with four 7/16 nuts, and the take-away belt with four 7/16 bolts. Remove the two nuts or bolts securing the belt frame to the casing on the side you wish to lift. Locate the rounded indents on the frame rail to find the nuts or bolts that secure the belt frame.

1. On the underside of the casing, locate the two 7/16 nuts or bolts securing the side of the belt frame you wish to lift.

NOTE: *To locate the take-away belt bolts, lower both crumb trays on the underside of the casing.*

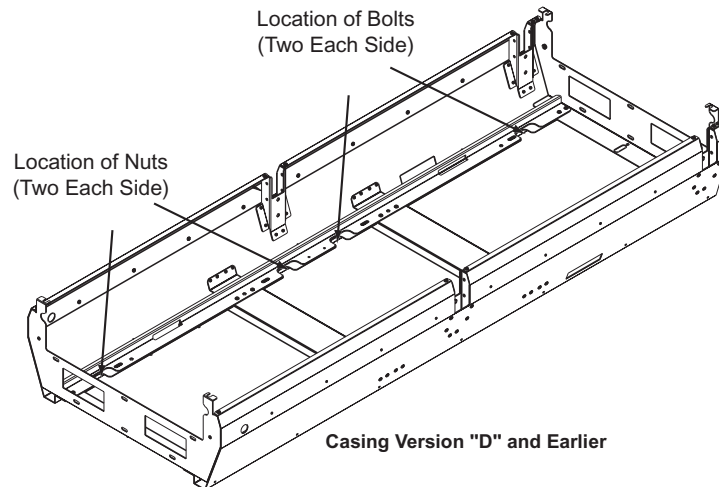

2. Remove the two nuts or bolts. Set aside.

8. Lift One Side of the Belt Frame

Gas struts keep one end lifted while the field engineer services the belt.

-
1. Loosen the outer tensioning nuts before you lift the belt. **Failure to do so can put strain on the bolts that secure the belt frame if the belt is fully tensioned when you secure it in place after servicing.**
 2. Lift the side of the belt you wish to service. For example, if you are replacing the motor, lift the motor side of the belt.

9. Remove the Belt Bed(s)

Remove **both** beds if you are replacing the belt or idler. Remove **only the smaller bed** to replace the motor.

Lift and remove the bed(s) you need to remove.

NOTE: *The smaller bed can be removed while the motor side of the belt is lowered. The longer bed can only be removed while the idler side of the belt is raised.*

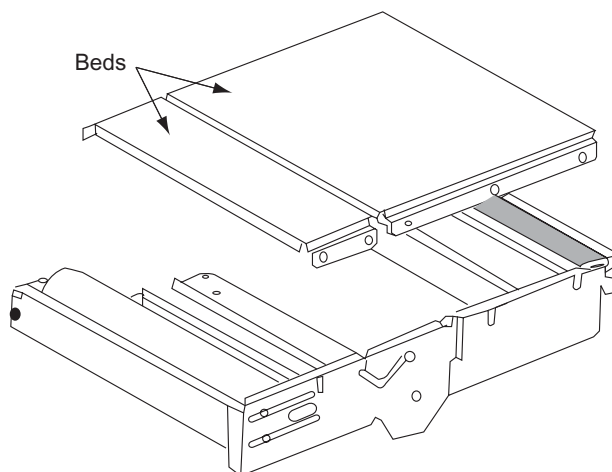

Replacing the Belt Components

Replacing the Belt Motor

1. Power Down the Station

Disconnect the controller board power cable.

OR

Turn off the **Power** switch on the controller board panel, if available.

2. Access the Belt Motor

Perform the tasks in [“Accessing the Belt Components”](#) on page 127. Lift the **smaller** end of the belt.

3. Remove the Ground Cable

1. Locate the ground cable for the motor you will replace:

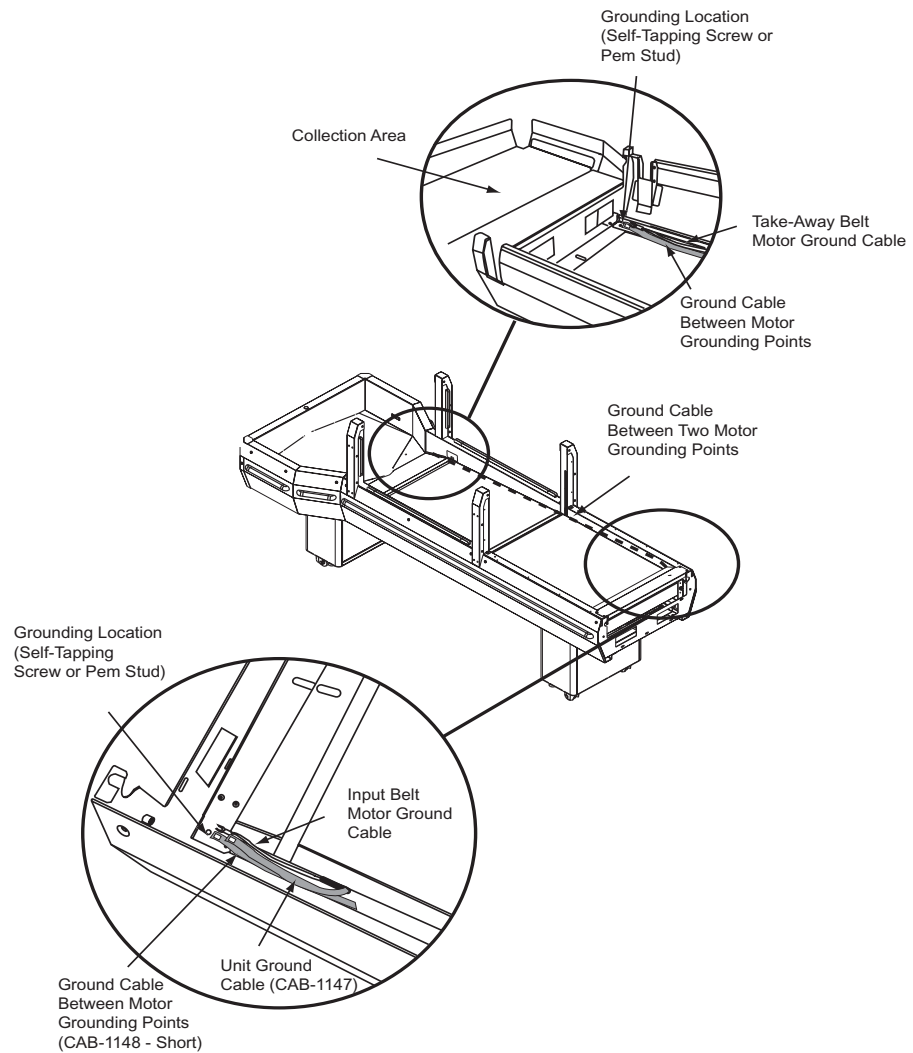

2. Loosen the ground screw or nut securing the ground cable(s).
3. Remove the motor ground cable. The termination is shaped as shown below.



4. Remove the Motor

While the belt is lifted, you can remove the motor.

1. Reach under the belt and grasp the motor.

-
2. Lift the motor partially up and out of the bracket, bringing the belt with it.

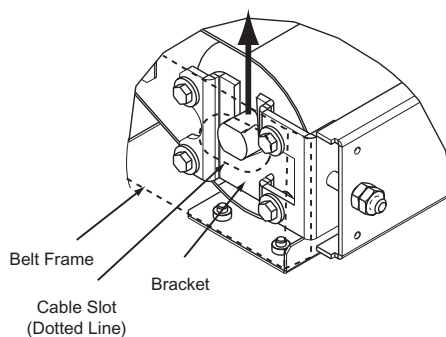

3. Thread the motor cable through the slot on the bracket. Carefully pull the connector head through the slot.
4. Remove the motor from the belt.

5. Install the New Motor

1. Slide the new motor through the belt.
2. Thread the belt motor cable through the cable slot on the belt frame.
3. Lift the belt and place the motor inside the belt above the frame.
4. Align the shafts on each side of the motor with the slots on the motor bracket inside the belt frame.
5. Set the motor in place.

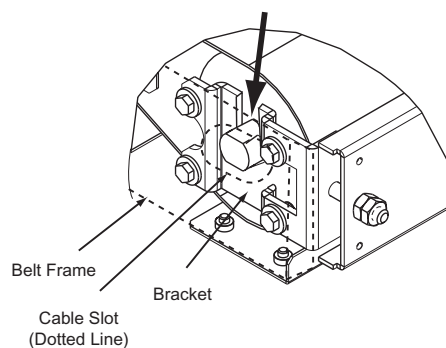

6. Pull the motor cable all the way through the cable slot.

6. Reassemble the Unit

1. Replace the bed.
2. **If you are replacing the take-away belt motor:**
 - a. Connect the take-away belt motor cable to cable “W” from the cable harness.
 - b. Secure the take-away belt ground cable to the grounding point at the rear of the

conveyor unit.

- c. Push the cable slack through the cable opening and into the collection area.

NOTE: Route the input belt motor cable after the belt is lowered and secured.

3. Lower the belt into operating position.

NOTE: If you did not loosen the tension adjustment nuts before raising the belt, do so now. If you secure the belt in the operating position when the belt is fully tensioned, strain is placed on the bolts securing the belt frame.

4. Replace the top nut on either side of the top of the belt frame.

NOTE: It is easier to tighten one nut partially, then the other, then tighten both fully.

5. Replace the nuts or bolts on the underside of the casing to secure the belt.

6. **If you are replacing the input belt motor:**

- a. Route the motor cable as shown below.

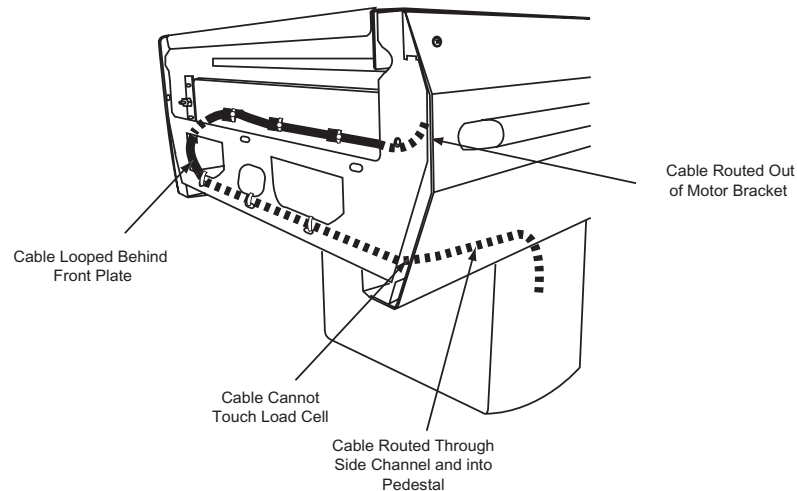

- b. Connect the input belt motor cable to cable “V” from the cable harness inside the pedestal.

NOTE: Provide a generous loop or curve on the motor cable. Ensure that the curve does not touch any component and that it is stable. Ensure that the motor cable is routed into the pedestal and is not stuck under the metal plate.

7. Replace any tie-wraps you cut.
8. Adjust the belt tracking and tension. Refer to [“Adjusting the Belt Tension and Tracking”](#) on page 73.
9. Replace the front and rear skirts.
10. Replace the sensor faceplates.
11. Replace the end-access tray or front guard plate.

Replacing the Idler

1. Power Down the Station

Disconnect the controller board power cable.

OR

Turn off the **Power** switch on the controller board panel, if available.

2. Access the Belt Idler

Perform the tasks in “[Accessing the Belt Components](#)” on page 127. Lift the **longer** end of the belt. Remove **both beds**.

3. Remove the Idler

1. With the idler side of the belt lifted, use an adjustable wrench to remove the 5/16” hex bolts and flat washers that secure the idler to the end of the belt frame.

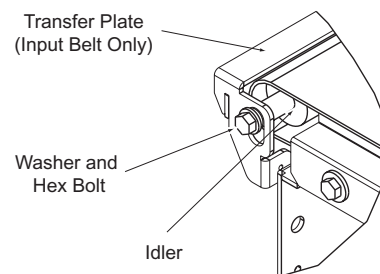

2. If you are replacing the idler on the input belt, remove the transfer plate.
3. Remove the idler from the belt frame.

4. Replace the Idler

1. Locate the new idler.
2. Slide the idler through the belt.
3. Align the holes on the idler with the holes on the belt frame.
4. If you are installing the idler on the **take-away belt**, fasten the 5/16 hex bolts and flat washers in the holes on either side of the belt frame.
5. If you are installing the idler on the **input belt**:
 - a. Holding the idler in position, align the holes on the transfer plate with the holes on the belt frame.
 - b. Fasten the 5/16 hex bolts and flat washers in the holes on either side of the belt frame.

5. Reassemble the Unit

1. Replace the bed(s).
2. Lower the belt into operating position.

NOTE: *If you did not loosen the tension adjustment nuts before raising the belt, do so now. If you secure the belt in the operating position when the belt is fully tensioned, strain is placed on the bolts securing the belt frame.*

3. Replace the top nuts.

NOTE: *It is easier to tighten one nut partially, then the other, then tighten both fully.*

4. Replace the nuts or bolts on the underside of the casing to secure the belt.
5. Adjust the belt tracking and tension. Refer to [“Adjusting the Belt Tension and Tracking”](#) on page 73.
6. If you replaced the idler on the input belt, ensure that objects pass easily from the input belt to the take-away belt. If you need to adjust the height of the transfer plate, refer to [“Adjusting the Transfer Bar Height”](#) on page 77.
7. Replace the front and rear skirts.
8. Replace the sensor faceplates.
9. Replace the end-access tray or front guard plate.

Replacing the Belt

1. Perform the tasks in [“Accessing the Belt Components”](#) on page 127 to access the idler. Lift the **longer** end of the belt. Be sure to remove **both beds**.
2. Remove the idler and transfer plate (if you are replacing the input belt). Refer to [“Remove the Idler”](#) on page 138.
3. Lift the back end of the motor up out of the frame. This is the end that does **not** have a cable fixed to it.
4. Slide the belt up and off the motor.
5. Slide the new belt onto the motor.
6. Replace the back end of the motor in the frame.
7. Replace the idler and transfer plate (if you are removing the input belt). Refer to [“Replace the Idler”](#) on page 138.
8. Reassemble the unit. Refer to [“Reassemble the Unit”](#) on page 139.

Replacing a Belt Scale Load Cell

Follow these steps to replace a belt scale load cell.

1. Locate the scale CPU inside the main unit.

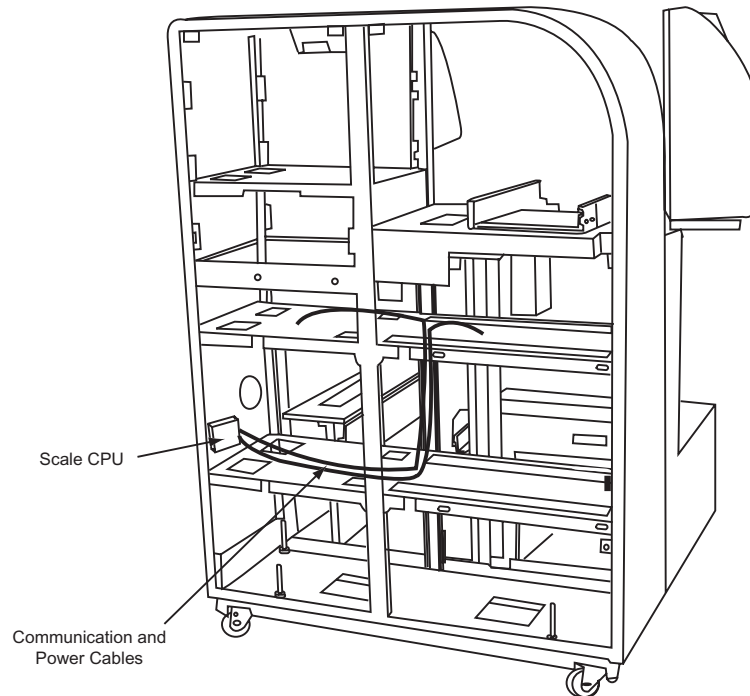

2. Disconnect the power cable from the scale CPU.
3. Disconnect both load cell cables from the scale CPU.
4. Perform the steps in [“Accessing the Belt Components”](#) on page 127 to lift the side of the input belt on which you will replace the load cell.
5. Remove the cable gland from the main unit and separate it it:
 - a. Unscrew the nut from the plastic cable gland.
 - b. Slide the plastic cable gland down onto the black plastic tubing.
 - c. Use a flat-head screwdriver to lift the large tab **gently** on the square portion of the plastic housing.

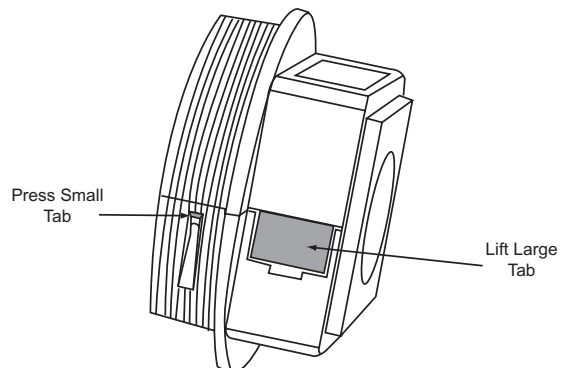

-
- d. At the same time, use another screwdriver to press the small tab on the circular portion of the plastic housing.
 - e. Gently move the two pieces 2-3 mm apart.
 - f. Repeat the steps above on the other side of the cable gland to fully separate it.
 - g. Remove the grommet from the cable gland.
 - h. Split the rubber grommet and pull out the cables.
6. Route the load cell cables through the cable hole on the main unit.
 7. Cut the three black tie-wraps on the black plastic tubing.

NOTE: *These tie-wraps **MUST** be replaced at the end of this procedure as per UL requirements.*
 8. Split the black plastic tubing.
 9. Pull the load cell cables up and out of the tubing a little at a time.
 10. Remove the cable gland from the conveyor unit and separate it:
 - a. Remove the screws securing the pedestal cover.
 - b. Follow step a to step h above to remove the cable gland.
 11. Route the cables into the pedestal.
 12. If necessary, cut any tie-wraps securing the cables inside the pedestal.
 13. Remove the two nuts and washers on the inside of the scale frame securing the load cell you wish to remove.

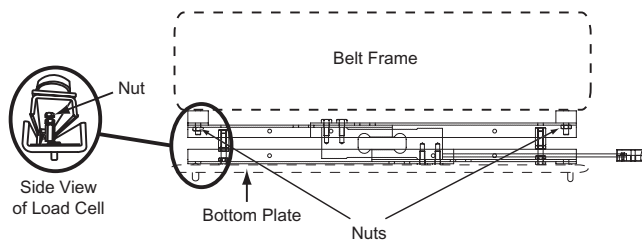

14. Remove the load cell and pull the cable up and out of the pedestal.
15. Position the load cell so that the black rubber stopper is facing up and the load cell cable is routed towards the center of the input belt.
16. Align the studs on the top of the load cells with the slots on the bottom of the belt frame.
17. From the top of the belt frame, replace the two nuts and washers you removed earlier to secure the load cell to the frame.
18. Route both load cell cables back through the plastic tubing and into the main unit.
19. Connect the load cell cables to the scale CPU.

20. Replace both cable glands.

21. Ensure that 4" of tubing is routed into the pedestal and into casing as shown below.

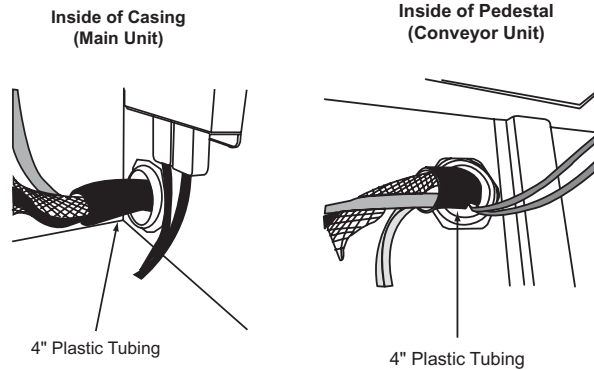

22. Install three black tie-wraps even spaced on the plastic tubing covering the cables between the main unit and the conveyor unit. These **MUST** be present on the unit as per the UL requirements.

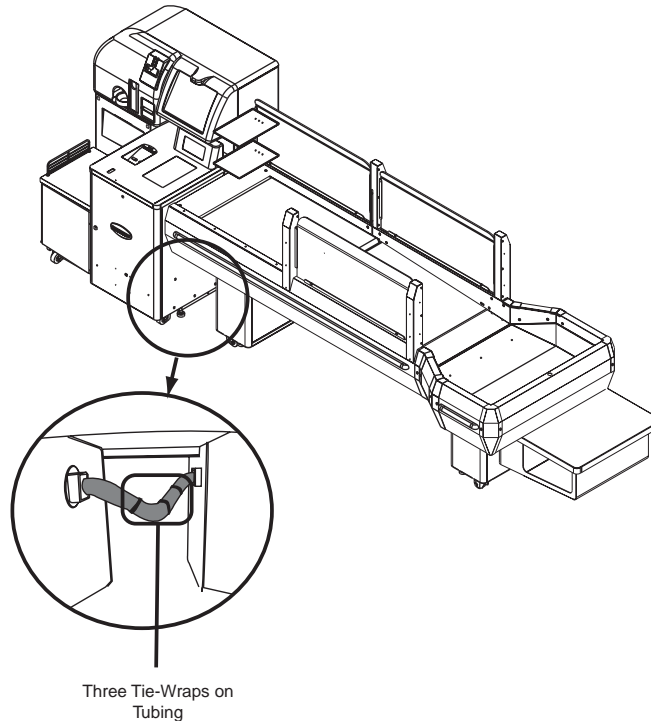

23. Reassemble the unit. Refer to [“Reassemble the Unit”](#) on page 136.

24. Calibrate the input belt scale. Refer to [“Calibrating the Input Belt Scale”](#) on page 64.

25. Test the input belt scale. Refer to [“Test the Input Belt Scale”](#) on page 58.

26. Test the input belt tension and tracking. Refer to [“Test the Input Belt \(Movement\)”](#) on page 56.

27. If necessary, adjust the input belt tension and tracking. Refer to [“Adjusting the Belt Tension and Tracking”](#) on page 73.

Replacing the SCALETRON CPU (Scale Brain)

1. Remove the back panels of the main unit.
2. Locate the scale CPU.

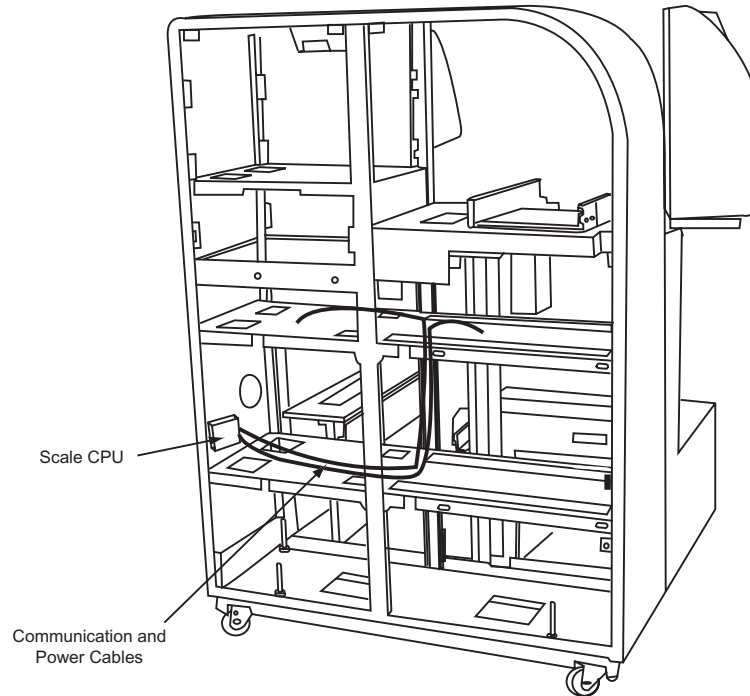

3. Disconnect the cables from the CPU.
4. Remove the CPU from the side of the wall.
5. Remove the Velcro from the bottom of the CPU and from the side of the casing.
6. Cut two strips of Velcro and affix them to the underside of the new scale CPU.
7. Install the CPU so that the power and communication cable ports are facing the **front** of the casing.
8. Connect the cables to the CPU.
9. Test the scale. Refer to [“Test the Input Belt Scale”](#) on page 41.
10. If necessary, calibrate the scale. Refer to [“Calibrating the Belt Scale Through the Device Tester”](#) on page 52.

Replacing the Controller Board Fuse

1. Power down the Station.
2. **Disconnect the controller board power cable from the AC outlet.**
3. Unlock and open the door below the input belt.
4. Loosen the two screws securing the controller board panel.
5. Slide the controller board panel toward you. If necessary, disconnect the communication cable from the controller board.
6. Locate the fuse. It is labeled with the text “10A.”

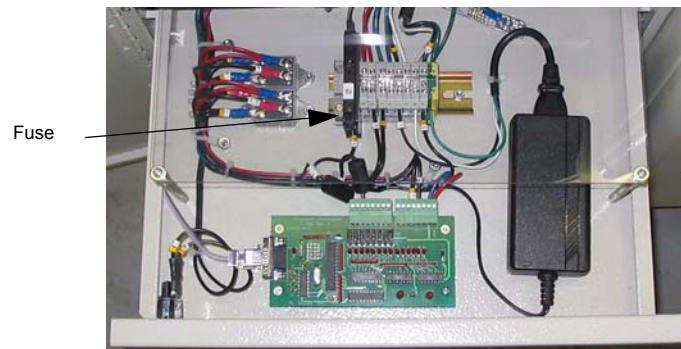

7. Remove the fuse.
8. Replace the fuse with 10 A, 3 AG Busman fuse.
9. Connect the controller board power cable.
10. Power on the Station.
11. Make sure that the red LED on the controller board lights.
12. Try the switches on the controller board and ensure that the appropriate component moves or that the appropriate LED lights. Refer to [“Testing the Belt Devices from the Controller Board”](#) on page 34.
13. Close the controller board panel.
14. Fasten the screws that secure the controller board panel.
15. Close and lock the Customer Station door.

Replacing the Controller Board

1. Remove the Controller Board

1. Power down the Station.
2. Remove the back panel of the main unit.
3. **Disconnect the controller board power cable.**
4. Disconnect the cable harness (cable “BC”).
5. From the back of the unit, partially route the controller board end of the cable harness into the cable opening behind the controller board. This cable is attached to the controller board and will need to be removed when you remove the controller board.
6. From the front of the main unit, unlock and open the computer compartment.
7. Use a Phillips screwdriver to loosen the two screws securing the controller board panel.
8. Slide the controller board panel toward you until the latch pin on the tray clicks into place.
9. Disconnect the controller board communication cable from port J3 of the controller board. If necessary, cut any tie-wraps securing the communication cable to the controller board.
10. Locate the ground stud on the controller board tray.



11. Remove the nut and ground cables from the stud. Leave the braided ground cable in the casing.

-
12. Lift the latch pin, then fully slide the controller board out of the unit.



2. Install the New Controller Board

1. Place the new controller board tray on the rails.
2. Remove the nut, star washer, and ground cable from the terminal block from the ground stud.
3. Thread the braided ground cable then the terminal block ground cable onto the ground stud.
4. Replace the nut to secure the two ground cables.



5. Route the cable harness (cable “BC”) through the hole on the shelf and into the back of the main unit.
6. Connect the cable harness to cable “BC” from the conveyor unit.
7. Connect the controller board communication cable to port J3 on the controller board.
8. **Replace any tie-wraps you cut when you removed the controller board.**

3. Complete the Procedure

1. Connect the controller board power cable to a dedicated AC outlet. **NEVER** connect the controller board power cable to the UPS.
2. Test both belts and the sensors. Refer to [“Testing the Belt Devices from the Controller Board”](#) on page 34.
3. Power on the Station.
4. Lift the latch pin (if present) and close the controller board panel.
5. Fasten the two screws.
6. Close and lock the door.

Crimping the Cables

Crimping the Communication Cables

Perform the steps below to crimp all cables with an AMP connector head. The procedure for crimping ground cables is slightly different. Refer to [“Crimping the Ground Cables”](#) on page 149 for instructions.

1. Disconnect the controller board power cable.
2. Strip the plastic cable covering back from the wires so that approximately 1/2” of the wires is revealed.
3. Refer to [“Cable Pin Assignments”](#) on page 151 to select the appropriate crimping pins (male or female crimping pin) depending on the cable you are crimping.

NOTE: *A male pin has a rounded closed end, and a female pin has a flat open end.*



4. Use the wiring diagram or table ([“Cable Pin Assignments”](#) on page 151) to determine how you will crimp the wires.

EXAMPLE: To crimp the rear take-away belt motor cable (device cable), you will need to place a pin on the white wire, one on the blue wire, and another on the black and red wires (together).

5. Align the bare wire(s) with the end of the pin, and the covered portion of the cable with the butt of the pin as shown below.

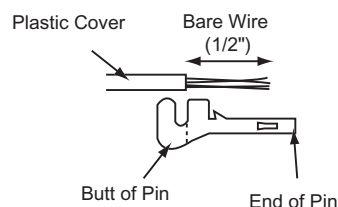

6. Place the pin and wire in the **18-22 AWG position** of a crimping tool. Make sure that the butt of the pin is in the deeper part of the groove.

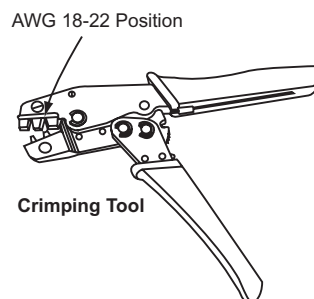

7. Squeeze the handles on the crimping tool together to crimp the cable.
8. Open the handles and remove the cable.
9. If necessary, refer to “[Cable Pin Assignments](#)” on page 151 to determine the type of connector head required (male or female, number of pins).

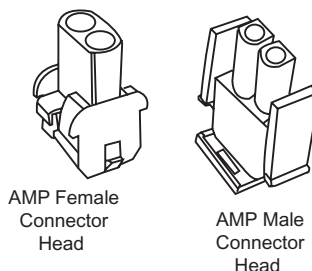

10. Locate pin 1 on the connector head. Pin 1 has a small ridge running along it on the side of the connector head.
11. Locate the wire holes on the connector head. They are the round holes.

	AMP Female Connector Head	AMP Male Connector Head
Wire Holes (Round)		
Connector End (Flat on One Side)		



*These diagrams show the top and bottom of the male and female connector heads.

12. Insert the wires into the wire holes on the connector head as indicated in the wiring diagram or table.
EXAMPLE: To crimp the take-away belt motor cable, insert the white wire into pin 1 (position 1) of the connector head.

Crimping the Ground Cables

1. Disconnect the controller board power cable.
2. Strip the plastic cable covering back from the ground cable so that approximately 1/2” of the wires is revealed.

-
3. Locate the appropriate ground termination for the ground cable you will crimp:

Ground Cable	Termination
BANNER sensor array For the following ground cables, this termination is used for casing version "B" and earlier. Casing versions "C" and later use a braided ground strap that does not require crimping. Main unit - conveyor UPS Controller Board	
Take-Away Belt Motor Input Belt Motor	

4. Insert the wire into the termination.
5. Use a standard wire crimping tool, such as a Klein tools Cat. no. 1000 wire stripper and crimper.
6. Insert the termination into the **14-22 gauge slot** of the crimping tool. Make sure that you can see the tip of the ground wire protruding from the plastic cable covering.

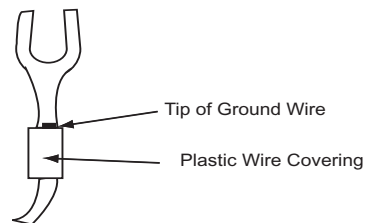

7. Crimp the ground cable right at the top of the plastic wire covering.

Cable Pin Assignments

Refer to “[Wiring Schematics](#)” on page 155 for the electrical schematic of the controller board and cables.

Cable	Pin Number	Label or Wire Color	DEVICE Connector and Pin Type	HARNESS Connector and Pin Type
Input Belt Motor or Take-Away Belt Motor (Cable V or W)	Pin 1	White	Connector: 3-pin Male Crimping Pins: Male	Connector: 3-pin Female Crimping Sockets: Female
	Pin 2	Blue		
	Pin 3	Black and red		
Take-Away Belt and Collection Area Sensors (Cable Y or Z)	Pin 1	Brown	Connector: 3-pin Male Crimping Sockets: Female	Connector: 3-pin Female Crimping Pins: Male
	Pin 2	Black		
	Pin 3	Blue		
Cable Harness	Pin 1	White	Connector: 15-pin Female Crimping Sockets: Female	Connector: 15-pin Male Crimping Pins: Male
	Pin 2	Blue		
	Pin 3	Black and red		
	Pin 4	White		
	Pin 5	Blue		
	Pin 6	Black and red		
	Pin 7	Brown		
	Pin 8	Black		
	Pin 9	Blue		
	Pin 10	Brown		
	Pin 11	Black		
	Pin 12	Blue		
	Pin 13 -15	n/a		
P1 BANNER sensor array cable assembly	Pin 1	Black	Connector: 2-pin male Crimping Pins: Male	N/A
	Pin 2	Red		
P2 BANNER sensor array cable assembly	Pin 1	Black	Connector: 2-pin female Crimping Sockets: female	N/A
	Pin 2	Red		

Cable	Pin Number	Label or Wire Color	DEVICE Connector and Pin Type	HARNESS Connector and Pin Type
P5 BANNER sensor array cable	Pin 1	Shield	8-pin male Crimping Pins: Male	N/A
	Pin 2	Black		
	Pin 3	Red		
	Pin 4	N/A		
	Pin 5	White		
	Pin 6	Green		
	Pin 7	Blue		
	Pin 8	Orange		
P6 BANNER sensor array cable	Pin 1	Shield	6-pin female Crimping sockets: Female	N/A
	Pin 2	Black		
	Pin 3	Red		
	Pin 4	N/A		
	Pin 5	White		
	Pin 6	Green		

Replacing the SCANGINEER Sensor Array Wires in the Cable Connection Head

1. If necessary, strip the wire.
2. Loosen the plastic screw on the side of the cable connection head.
3. Place the appropriate wire in the slot. Refer to the table below for the pin assignments.

Cable Description	Pin Number	Wire Color
2-pin green Phoenix connector	Pin 1	Red
	Pin 2	Green
6-pin green Phoenix connector	Pin 1	White
	Pin 3	Black
4-pin green Phoenix connector	Pin 1	White
	Pin 2	Brown
	Pin 3	Green
	Pin 4	Yellow

4. Tighten the plastic screw to secure the wire in the connection head.

Wiring Schematics

Controller Wiring Diagram

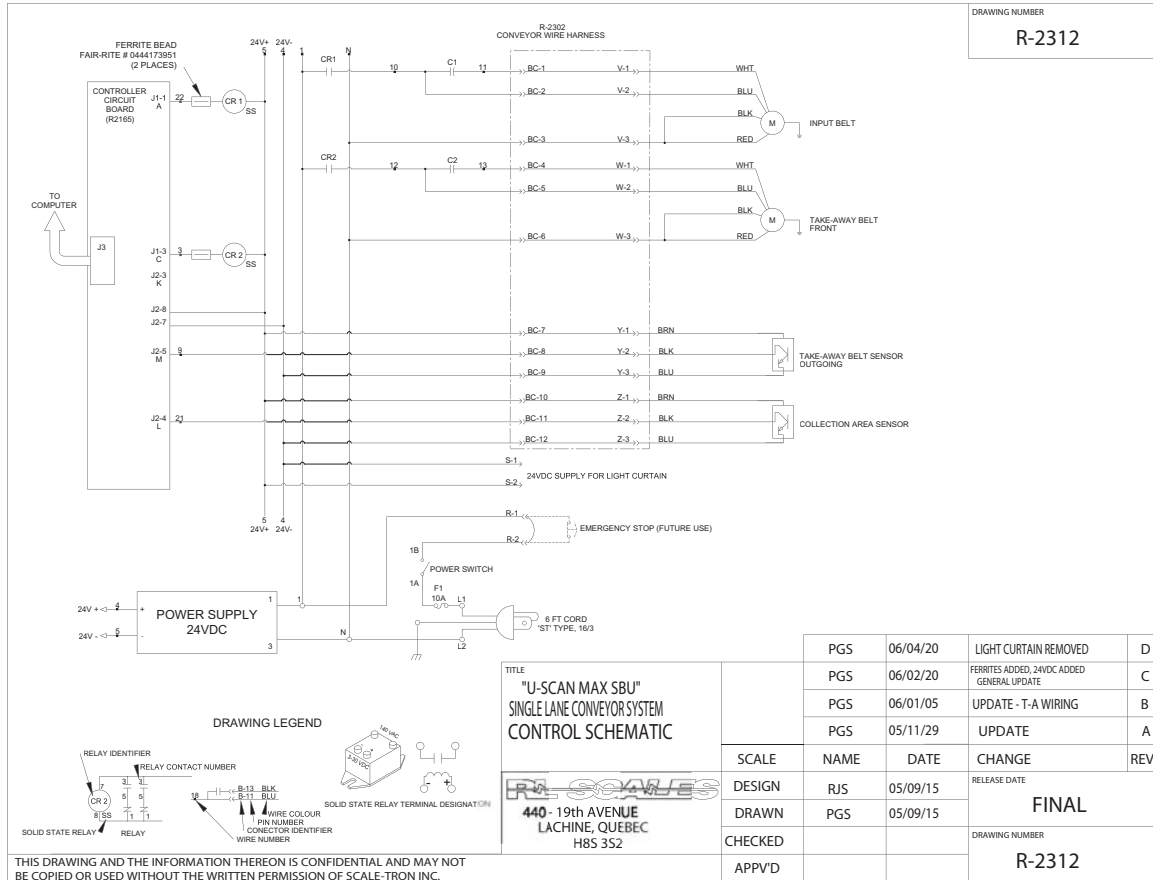

Cable Wiring Diagrams

Cable Harness

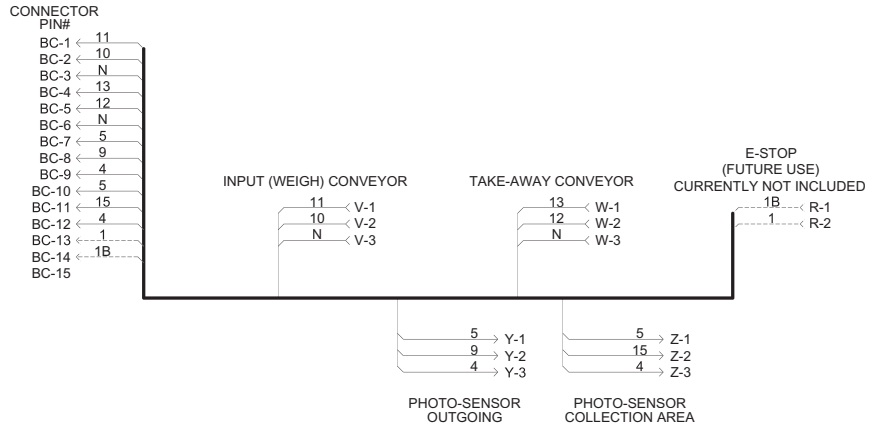

BANNER Light Curtain Cable Assembly

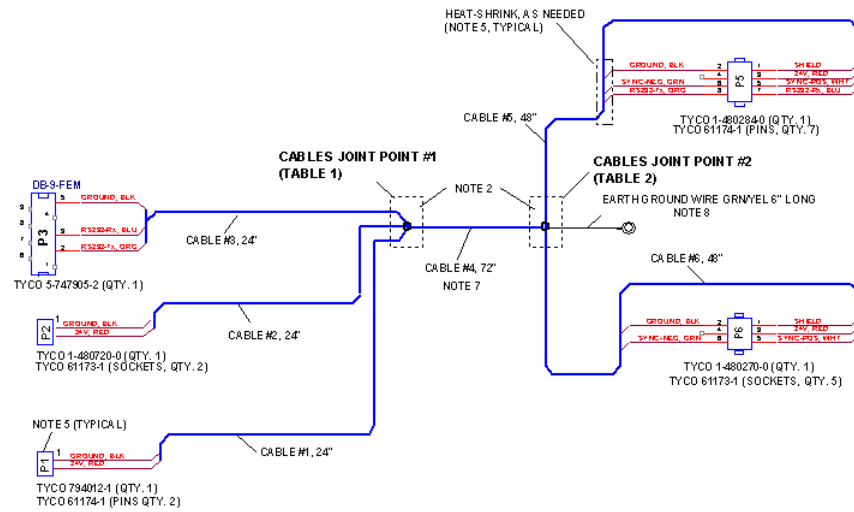

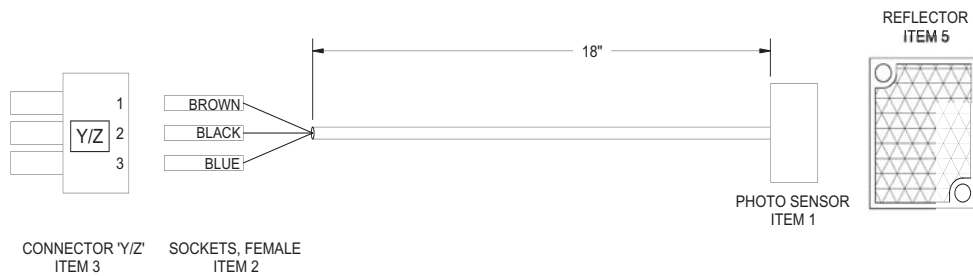

Take-Away Belt (Cable Y) and Collection Area (Cable Z) Sensors

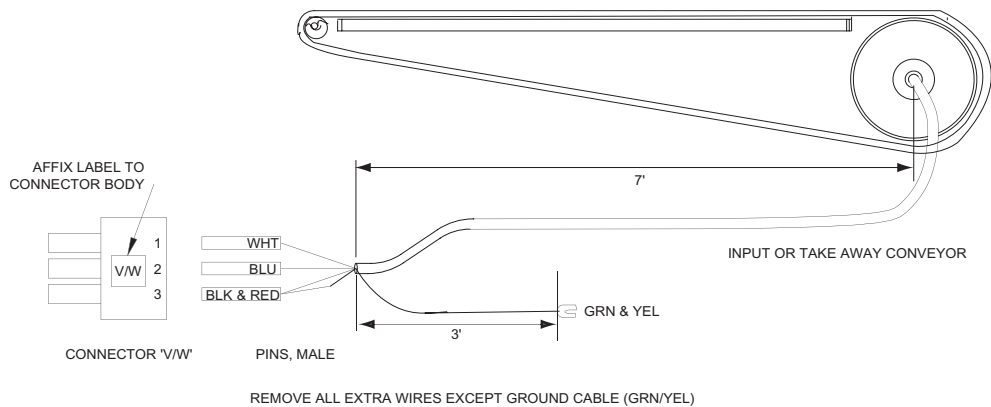

THIS PHOTO SENSOR IS NOW COMMON FOR ALL PHOTO SENSOR POSITIONS

Input Belt Motor (Cable V) or Take-Away Belt Motor (Cable W)



FUJITSU

THE POSSIBILITIES ARE INFINITE