

**F7521F BAR CODE SCANNER
USER'S GUIDE**



REVISION RECORD		
Edition	Date published	Revised contents
01	Dec. 2002	First edition
Specification No.: C150-E218-01EN		

The contents of this manual are subject to change without prior notice.

All Rights Reserved,
Copyright © 1999, 2001 FUJITSU LIMITED

IMPORTANT NOTE TO USERS

READ THE ENTIRE MANUAL CAREFULLY BEFORE USING THIS PRODUCT. INCORRECT USE OF THE PRODUCT MAY RESULT IN INJURY OR DAMAGE TO USERS, BYSTANDERS OR PROPERTY.

While FUJITSU has sought to ensure the accuracy of all information in this manual, FUJITSU assumes no liability to any party for any damage caused by any error or omission contained in this manual, its updates or supplements, whether such errors or omissions result from negligence, accident, or any other cause. In addition, FUJITSU assumes no liability with respect to the application or use of any product or system in accordance with descriptions or instructions contained herein; including any liability for incidental or consequential damages arising therefrom.

FUJITSU DISCLAIMS ALL WARRANTIES REGARDING THE INFORMATION CONTAINED HEREIN, WHETHER EXPRESSED, IMPLIED, OR STATUTORY. FUJITSU reserves the right to make changes to any products described herein without further notice and without obligation.

**Federal Communications Commission Radio Frequency
Interference Statement**

FCC STATEMENTS:

This equipment has been tested and found to comply with the limits for a Class A digital device, pursuant to Part 15 of the FCC Rules.

These limits are designed to provide reasonable protection against harmful interference when the equipment is operated in a commercial environment.

This equipment generates, uses, and can radiate radio frequency energy and, if not installed and used in accordance with the instruction manual, may cause harmful interference to radio communications. Operation of this equipment in a residential area is likely to cause harmful interference in which case the user will be required to correct the interference at his own expense.

FCC WARNING:

Changes or modifications not expressly approved by the party responsible for compliance could void the user's authority to operate the equipment.

**Canadian Department of Communications Radio
Frequency Interference Statement**

This digital apparatus does not exceed the Class A limit for radio noise emissions from digital apparatus set out in the Radio Interference Regulations of the Canadian Department of Communications.

Le présent appareil numérique n'émet pas de bruits radioélectriques dépassant les limites applicables aux appareils numériques de la Class A prescrites dans le Règlement sur le brouillage radioélectriques édicté par le Ministère des Communications du Canada.

Warning on Use Requiring Extremely High Safety Levels

This Product is designed, developed and manufactured as contemplated for general use, including without limitation, general office use, personal use and household use, but is not designed, developed and manufactured as contemplated for use accompanying fatal risks or dangers that, unless extremely high safety is secured, could lead directly to death, personal injury, severe physical damage or other loss (hereinafter "High Safety Required Use"), including without limitation, nuclear power core control, airplane control, air traffic control, mass transport operation control, life support, weapon launching control. You shall not use this Product without securing the sufficient safety required for the High Safety Required Use. If you wish to use this Product for High Safety Required Use, please consult with our sale person in charge before such use.

Laser Safety Statement

The F7521F is designed to meet CDRH Class II a and IEC825 Class 1; laser safety regulations.

ENGLISH

F7521F scanner is certified in the U.S. to conform to the requirements of DHHS CDRH 21 CFR Subchapter J for Class IIa laser products. The F7521F is also certified as a Class 1 laser product which meets the requirements of IEC825-1:1993.

IEC Class 1 and CDRH Class IIa products are not considered to be hazardous. The F7521F contains a visible laser diode (VLD) that emits a maximum of 0.88 milliwatts at a wavelength of 650 nanometers. The F7521F is designed so that there is no human exposure to harmful laser light during normal operation, user maintenance or prescribed service operations.

CAUTION: The use of controls, making adjustments or using procedures other than those specified herein may result in exposure to hazardous laser light.

CAUTION: Do not attempt to open or otherwise service any component in the optics cavity.

Opening or servicing any part in the optics cavity may violate laser safety regulations. The optics system is factory-only repair.

CAUTION: The use of optical instruments with the scanner will increase the damage to eyes. Optical instruments include binoculars, microscopes and magnifying glasses but do not include eye glasses.

GERMAN

Der F7521F entspricht den in den Vereinigten Staaten geltenden Vorschriften des DHHS/CDRH 21CFR Subchapter J für Laserprodukte der Klasse II a (Class II a). Der F7521F ist ferner als ein Laserprodukt der Klasse 1 (Class 1) nach den Vorschriften der IEC 825-1:1993 zugelassen.

Produkte der Klasse 1 (Class 1) sind als ungefährlich eingestuft.

Der F7521F enthält eine VLD Diode, die maximal 0.88 Milliwatt auf einer Wellenlänge von 650 Nanometer ausstrahlt. Der Scanner ist so konstruiert, daß während des normalen Betriebs, der Wartung durch den Benutzer oder der vorgeschriebenen Wartungsvorgänge kein Zugang zu schädlichen Laserlichtstufen möglich ist.

VORSICHT

Bitte benutzen Sie nur den Transformator, der dem Gerät mitgeliefert ist, oder einen gleichwertigen Transformator.

VORSICHT

Jegliche Anwendung von Streuungen, Reglern oder anderen Verfahren, die nicht in diesen Ausführungen erwähnt werden, können eine gefährliche Laserlichtbestrahlung zur Folge haben.

VORSICHT

Das optische System darf nur vom Werk repariert werden. Das Öffnen oder Warten von Bestandteilen des optischen Hohlraums durch unbefugtes Personal verletzt die Laser Sicherheitsbestimmungen.

FUJITSU reserves the right to make changes to any products herein to improve reliability, function, or design, without further notice and without obligation.

Scale regulatory

Country, state and local regulatory agency notification of an installation of a weighing device may be required. Failure to comply with Weights and Measures regulations can result in criminal prosecution of individuals and can jeopardize the ability to conduct normal business.

PREFACE

Operating environment

The F7521F bar code scanner is a part of a Point-Of-Sales (POS) system for reading bar code labels printed on or attached to products, and is designed to be used in stores.

Use of the F7521F out side of the operating environment described above may result in unexpected injury to users, bystanders, or damage to their property.

Alerts

This manual uses the following conventions to provide alert information to prevent physical injury or property damage.



⚠ WARNING indicates that personal injury will occur if the user does not perform the procedure correctly.





⚠ CAUTION indicates that minor or moderate personal injury may occur if the user does not perform the procedure correctly. This alert also indicates that damage to equipment, data, or property, may occur if the user does not perform the procedure correctly.

Alert marks

In this manual, alert marks are used to describe safety precautions. The marks are described below. Read the following explanations carefully before reading the rest of the manual.

 Electric shock	Do not touch the plug with wet hands. When unplugging, hold the plug, not the cable.
---	--

 Laser light	Avoid viewing direct laser light.
--	-----------------------------------

 Fire	Do not use a voltage that is outside the rated voltage. Avoid starburst wiring.
---	---

 Electric shock	Always ground the F7521F. Always use a 3-prong plug. If a ground is not available, contact a sales representative or the service department for assistance.
--	---

 Caution	If the reading window breaks, be careful when handling the broken glass and do not touch the internal revolving mirror.
--	---

 Do not disassemble	Do not disassemble, change, or modify the unit.
---	---

 Fire	If the unit generates unusual heat, smoke, smells or sounds, unplug it immediately. Do not attempt to repair the unit yourself, you may be injured.
---	---

HANDLING NOTE

Maintenance

Do not repair the unit yourself. Please contact a sales representative or service department for maintenance.

CONTENTS

CHAPTER 1 OVERVIEW.....	1
CHAPTER 2 COMPONENTS.....	2
<input type="checkbox"/> Checking components	2
<input type="checkbox"/> Name and functions	3
CHAPTER 3 INSTALLATION.....	5
<input type="checkbox"/> Precautions before installation.....	5
<input type="checkbox"/> Connection.....	6
<input type="checkbox"/> Check barcode reading	9
CHAPTER 4 LASER SAFETY	10
CHAPTER 5 OPERATION.....	12
<input type="checkbox"/> Scanning	12
<input type="checkbox"/> Cleaning and window replacement.....	14
CHAPTER 6 FAILURES.....	15
CHAPTER 7 SCANNER SETTING	16
CHAPTER 8 SCALE	21
APPENDIX A	27
<input type="checkbox"/> Installation specifications	27
APPENDIX B	30
<input type="checkbox"/> Power cable selection	30
<input type="checkbox"/> AC adapter specification	30

CHAPTER 1 OVERVIEW

This manual describes how to install and operate the F7521F scanner. The F7521F is a high performance barcode reader that may be installed with an optional weigh scale module that can be integrated into the scanner chassis without increasing below counter depth of the device.

The F7521F is designed for use in retail store environments utilizing central checkout operations requiring high customer throughput. The F7521F scanner reads the barcode label on a product as it is passed through the scan patterns projected through the side and bottom windows of the scanner. The data from the barcode label is sent to the Point-Of-Sales (POS) terminal for comparison to the store item file. If the item is located in the PoS item file, the product description and price are retrieved from the file and that information is displayed on the customer display and printed on the customer receipt tape.

The optional scale module provides the weighing function. The weight data is transmitted to the POS terminal for price calculation and entry onto the customer order total. There is an optional Remote Weight Display available for those POS environments where the POS terminal is unable to display weight data on the customer display.

CHAPTER 2 COMPONENTS

After unpacking the F7521F barcode scanner, confirm that all components have been included.

Checking components

The F7521F is a high precision product, care should be taken when removing from the shipping package. Confirm that all the components shown In Table 2.1 have been received. If any components are missing, please contact the service provider or sales representative.

If the shipping container is torn or damaged, examine the unit to make sure that there is no damage.

Table 2.1 Components list

Item	Component name	pcs	note
1	OPERATER'S GUIDE (this manual)	1	
2	F7521F Scanner (or Scanner Scale)	1	
3	AC Adapter	1	
4	AC Power cord (Mains cable)	1	Optional
5	PoS Interconnect cable(s)*	set	Optional
6	EAS Cable(s)*	1	Optional
7	Platter(*)	1	Optional
8	Remote Scale Display(*)	1	Optional
*	May be packaged separately		

□ Name and functions

This section identifies the control panel switches, LEDs, and components of the F7521F and their functions.

Exterior view of the F7521F barcode scanner.

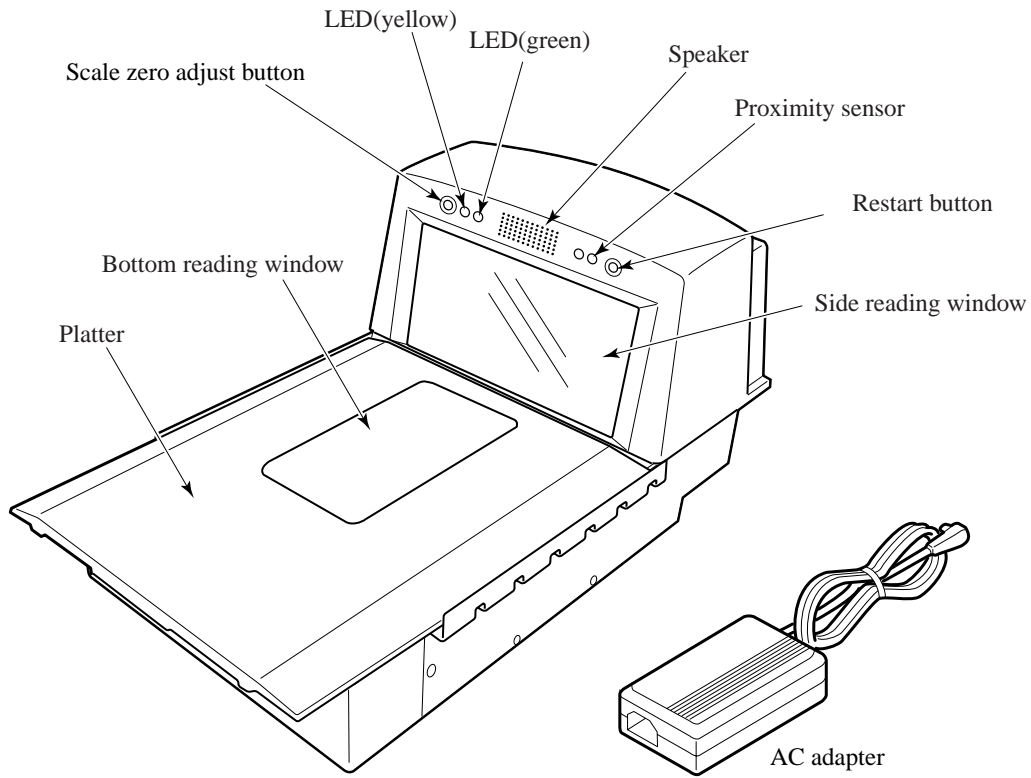

Functions

Restart button	Push the button to restart the scanner after it has entered power save (i.e., "Sleep") mode. Depress and hold the switch to adjust the speaker volume or tone.
Proximity sensor	When the sensor detect motion or movement the scanner will be restarted from power save mode.
LED display	Indicates operating state. Scanner status Green: Successful read Blank: Between reading Yellow: Sleep mode Scanner failure Indicates the alarm details when a failure occurs. See Chapter 6, Table 6.1 or Table 6.2
Reading windows	Emits laser beam (i.e., scan pattern) to read bar code.
Speaker	Emits tone after barcode had been decoded. Note: Volume and tone are adjustable.
Scale zero adjust button	Push this button to adjust scale zero value.

CHAPTER 3 INSTALLATION

This chapter explains the installation specifications and procedures for the F7521F barcode scanner.

Precautions before installation

Note the precautions below before installing the F7521F barcode scanner. See Appendix A "Installation specifications" for details on installation conditions. As the scanner does not have a power switch, make sure a power outlet is located within the operator's reach.

Keep the scanner away from electrical noise sources and strong magnetic fields. If the scanner is used near an air conditioner, a copying machine, or a TV set, it may not operate correctly.

Keep the scanner out of the sun and away from heaters. These environments may shorten the scanner life or cause hardware failures.

Do not install the scanner in an environment subject to vibration. Vibration may cause hardware failures or otherwise cause the scanner to operate incorrectly.

Do not install the scanner in humid, dusty, or damp environments. These environments may shorten the scanner life or cause hardware failures.

Static electricity may cause the scanner to operate incorrectly. Ensure that flooring and checkout counter materials do not generate static electricity.

□ Connection

Connect the F7521F bar code scanner using the following procedure:

⚠ WARNING	 <p>Do not touch the plug with wet hands. When unplugging, hold the plug, not the cable.</p> <p>Electric shock</p>
------------------	---

⚠ CAUTION	 <p>Avoid viewing direct laser light.</p> <p>Laser light</p>
------------------	---

① Unplug the power cable

Before connecting cables or options, unplug the power cable.

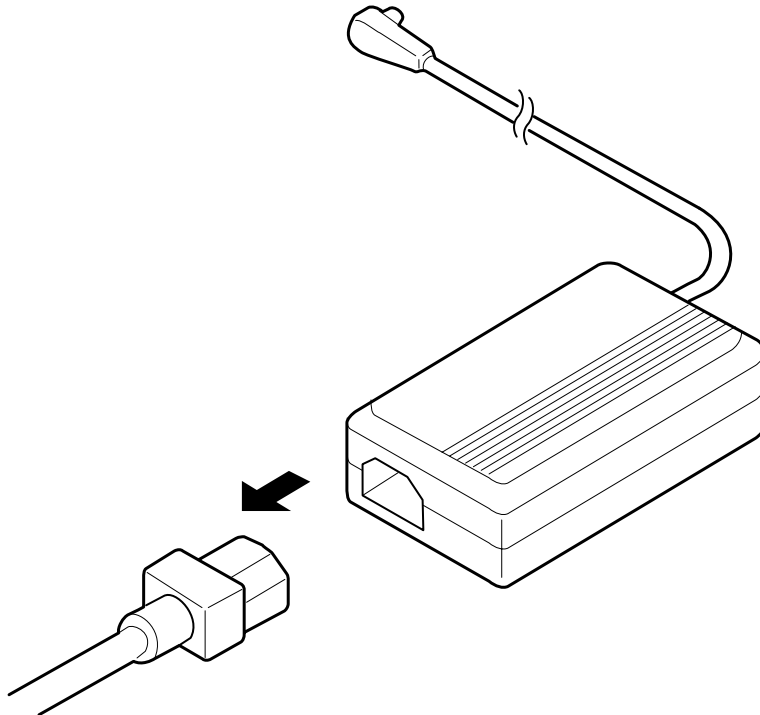

② RS232C/IBM Port.

Connect one end of the POS interface cable to the interface connector on the F7521F and tighten the connection screws then connect the other end of the cable to the host system (PoS terminal) and tighten the connection screws.

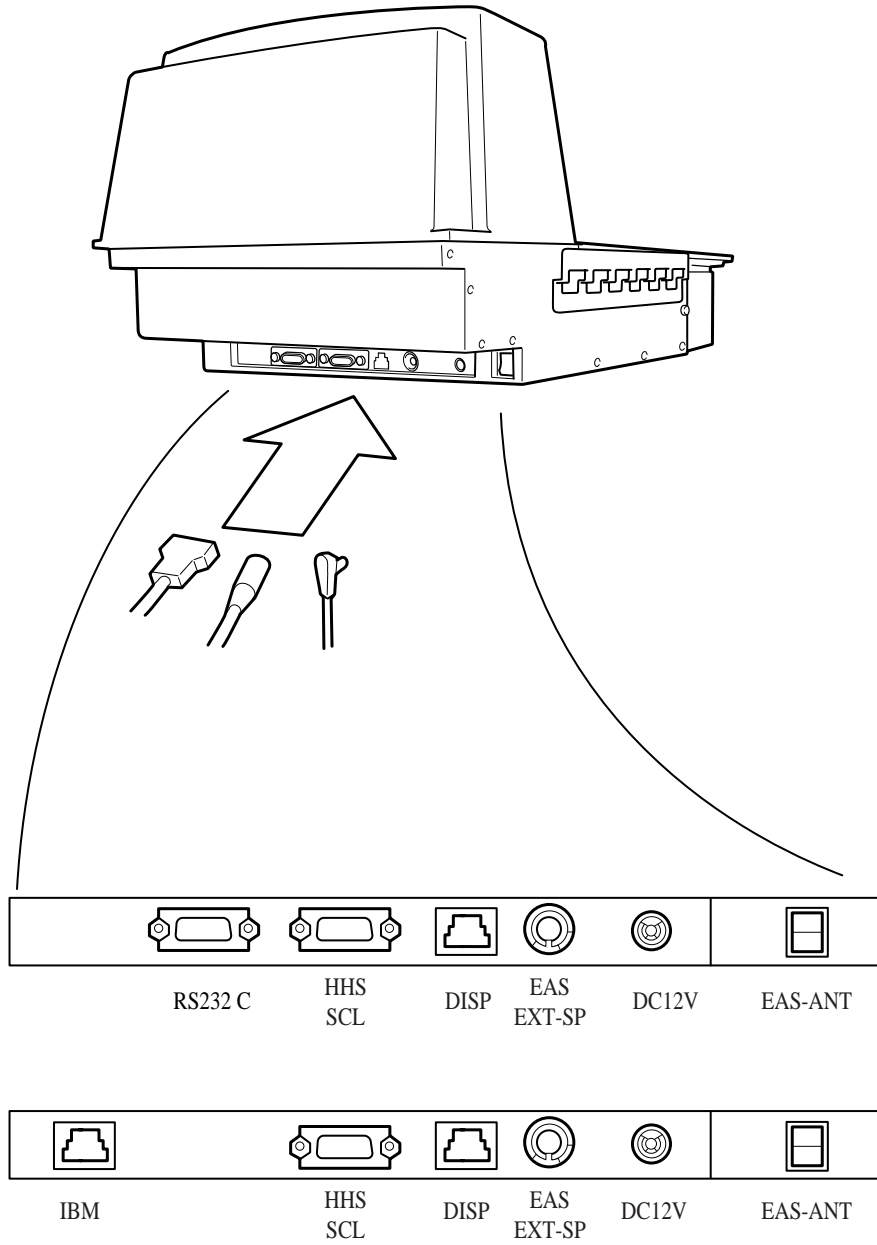

③ HHS/SCL Port

Optional Scanner (Handheld Scanner) or Scale interface cable can be connected to this port. Fit the cable to the connector and tighten the screws.

④ Connect the power cable

⚠ WARNING



Always ground the F7521F. Always use a 3-prong plug. If a ground is not available, contact a sales representative or service department for assistance.



If the unit generates unusual heat, smoke, smells or sounds, unplug it immediately. Do not attempt to repair the unit yourself, you may be injured.

⚠ CAUTION



Do not use a voltage that is outside of the rated voltage. Avoid starburst wiring.

Connect the AC adapter cable to the power jack on the back of the scanner.
Connect the power cable to the AC Adapter and then to power outlet.

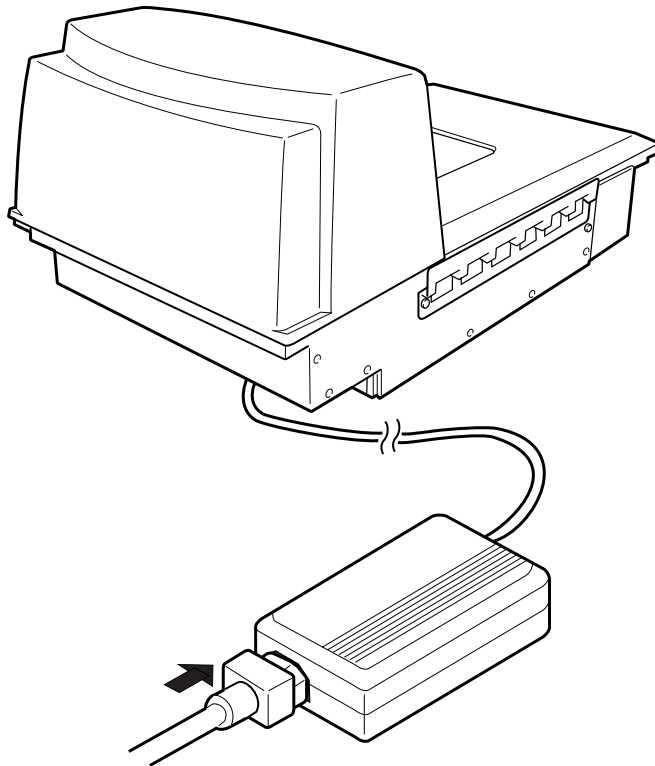

□ Check barcode reading

To set barcode reading functionality of the F7521F use the following procedure.

(1) Power on the F7521F by connecting power cable to AC adapter.

note : In case of remote power on mode (ex. F7521F53, F7521F73), connect power cable to AC adapter while depressing Re-start button.

(Please depressing Re-start button until green LED blink)

(2) Scan the barcode label provided below. The F7521F will be switched to "Test Mode" operation. In this state barcode label data will not be transmitted to the PoS terminal.

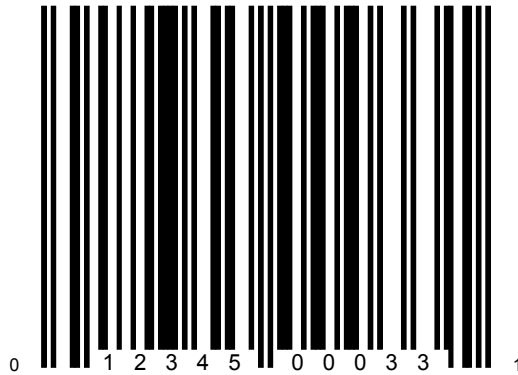







(3) Test barcode label reading by using sample barcode labels or items.

(4) Upon completion of tests, power off the F7521F.

(F7521F bar code scanner return to normal condition by power off)

CHAPTER 4 LASER SAFETY

The F7521F barcode scanner requirements for laser safety are based on IEC Standard Publications 825 and CDRH 21CFR, Chapter 1, Subchapter J and the (CDRH) Laser Product Performance Standard published November 28, 1978, User information [1040.10 (h)]

 CAUTION	<table><tr><td data-bbox="521 485 618 583"> Laser light</td><td data-bbox="651 485 1036 548">Avoid viewing direct laser light. Do not open the cover.</td></tr><tr><td data-bbox="521 615 618 714"> Caution</td><td data-bbox="651 615 1339 709">The use of controls, making adjustments or using procedures other than those specified herein may result in exposure to hazardous radiation.</td></tr></table>	 Laser light	Avoid viewing direct laser light. Do not open the cover.	 Caution	The use of controls, making adjustments or using procedures other than those specified herein may result in exposure to hazardous radiation.
 Laser light	Avoid viewing direct laser light. Do not open the cover.				
 Caution	The use of controls, making adjustments or using procedures other than those specified herein may result in exposure to hazardous radiation.				

1. Maintenance

Other than cleaning of the scan windows (side and bottom windows), no user maintenance is required.

2. Laser power

The F7521F uses an embedded Class 3B visible laser diode (VLD) operating at 650 nm and an opto-mechanical scanner system which results in less than 880mW peak output power at the outside scan window.

3. Adjustment or alteration

The user must not attempt to adjust or alter any component or module located inside the scanner's housing.

4. Motor failure

If the scanner motor were to fail while emitting a laser beam, the emission level would exceed the level for inherently safe operation. The F7521F has built-in safeguards to prevent this from occurring. However, in the event of motor failure the scanner should be disconnected from the power source and repaired.

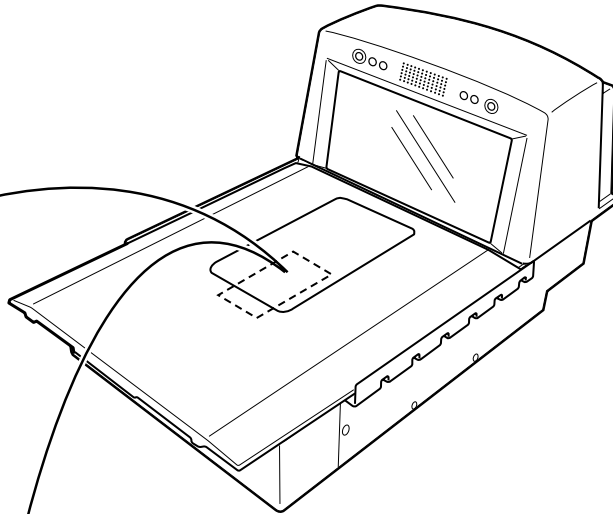

CDRH CLASS 1a LASER PRODUCT
 AVOID LONG-TERM VIEWING
 OF DIRECT LASER LIGHT
 PRODUIT A LASER (CDRH CLASSE 1a)
 EVITER DE FIXER TROP LONGTEMPS
 UNE LUMIERE - LASER

CAUTION: LASER LIGHT WHEN OPEN
 DO NOT STARE INTO BEAM
 ATTENTION: RAYONNEMENT LASER
 EN CAS D'OUVERTURE
 NE PAS REGARDER DANS
 LE FAISCEAU
 VORSICHT: LASERSTRAHLUNG, WENN
 ABDECKUNG GEÖFFNET
 NICHT IN DEN STRAHL
 BLICKEN

LASER WAVELENGTH : 640-660 nm
 PEAK OUTPUT POWER : 0.880 mW

注意・ここを開くとレーザー光が出ます。
 レーザ光をのぞき込まないこと。

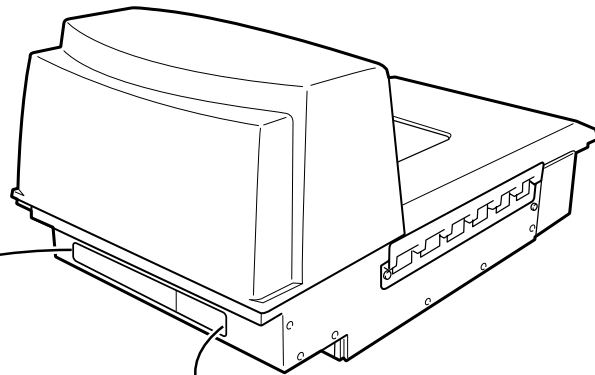

MODEL F7521FXX (XXXXXXXX)
 PART NO. / REV. KD02152-BXXX / XX
 MANUFACTURED DECEMBER, 2002
 SERIAL NO. 123456
 INPUT +12V ...
 MADE IN JAPAN
 FUJITSU LIMITED
 1-1-KARIKADAKA 4-CHOMEIENAKAHARA-KU, KAWASAKI, KANAGAWA, JAPAN



THIS DEVICE COMPLIES WITH PART 15 OF FCC RULES. OPERATION IS SUBJECT TO THE FOLLOWING TWO CONDITIONS: (1) THIS DEVICE MAY NOT CAUSE HARMFUL INTERFERENCE, AND (2) THIS DEVICE MUST ACCEPT ANY INTERFERENCE RECEIVED, INCLUDING INTERFERENCE THAT MAY CAUSE UNDESIRED OPERATION.
 THIS CLASS A DIGITAL APPARATUS MEETS ALL THE REQUIREMENTS OF THE CANADIAN INTERFERENCE-CAUSING EQUIPMENT REGULATIONS.
 CET APPAREIL NUMÉRIQUE DE LA CLASSE A RESPECTE TOUTES LES EXIGENCES DE REGLEMENT SUR LE MATERIEL BROUILLEUR DU CANADA.

THIS LASER PRODUCT COMPLIES WITH 21 CFR 1040 AS APPLICABLE.
 CERTIFIED ONLY TO THE CANADIAN ELECTRICAL CODE.
 CERTIFIÉ EN VERTU DU CODE CANADIEN DE ÉLECTRICITÉ SEULEMENT.

CLASS 1 LASER PRODUCT
APPAREIL À LASER DE CLASSE 1
LASER KLASSE 1
 クラス1レーザー製品

CHAPTER 5 OPERATION

The daily use of the F7521F involves scanning barcode labels and occasional cleaning the scan windows. The following sections explain those procedures.

 CAUTION	 Laser light	Avoid viewing direct laser light.
	 Caution	If the reading window breaks, be careful when handling the broken glass and the internal revolving mirror.

□ Scanning

The barcode on the product should be passed through the center of the reading area. The mesh area in the figure below shows the readable area.

If the barcode is read, the green LED blinks once and the speaker "beeps". If the read is unsuccessful, the LED does not change and the speaker does not sound.

If the F7521F is inactive for a period of time, the automatic power-save function is activated and the laser and motor are turned off. To restart the laser and motor depress the Restart button or pass an object over the proximity sensor.

Side window reading area

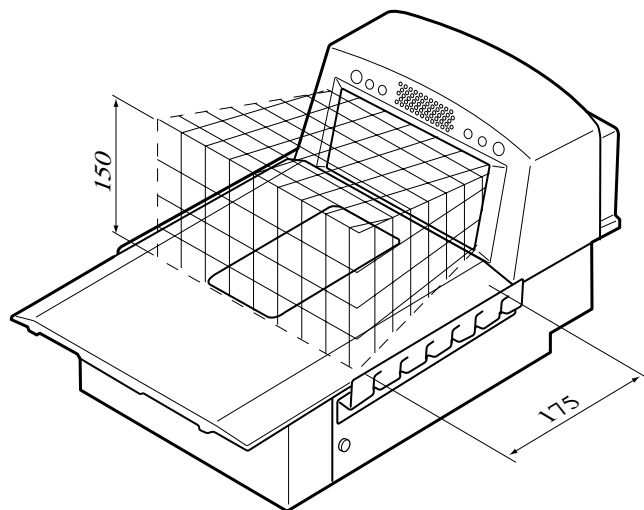

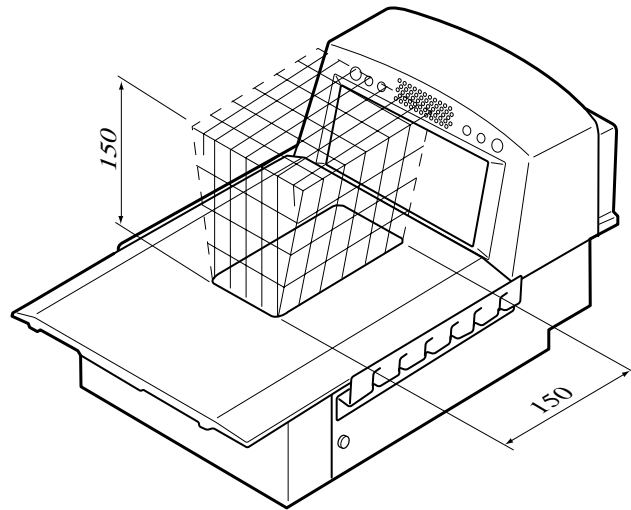

Bottom window reading range

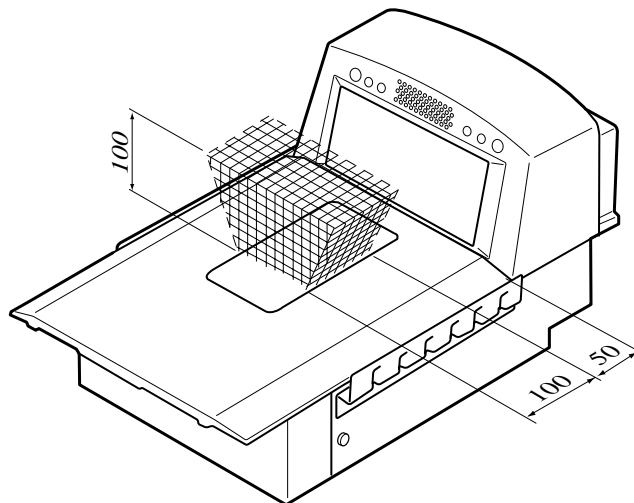

Sweet spot area



□ Cleaning and window replacement

 CAUTION	 Caution  Laser light Avoid viewing direct laser light. If the reading window breaks, be careful when handling the broken glass and do not touch the internal revolving mirror.
---	--

Cleaning

A dirty or stained reading window can result in poor read performance or failure to read. The reading windows should be cleaned regularly to ensure good reading performance. Use the soft cloth or tissue paper to wipe dirt or stains off of the reading window.

Window replacement (side window only)

The side reading window is replaceable. To replace the window, first remove the bezel as shown below and then carefully remove the glass window.

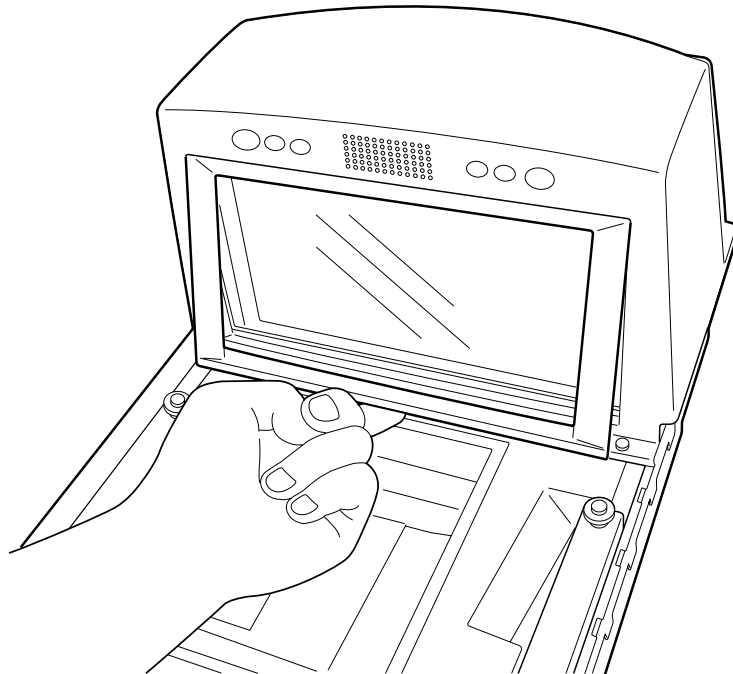



CHAPTER 6 FAILURES

The F7521F is equipped with run-time and power-up diagnostics that continuously checks itself for failures. In the event of a failure, the LED's will flash in a designated pattern to indicate the type of failure (see Table 6.1 or Table 6.1 for detailed descriptions).

If a failure occurs, contact a sales representative or the service department for assistance.

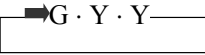
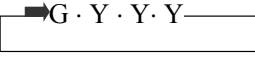
Table 6.1 Alarm indications

Failure	Alarm display (LED)	Description
Motor alarm		Motor rotation error
Laser alarm		Laser circuit error
ROM alarm		ROM check error
RAM alarm		RAM check error

E.g., "." indicates a blink. In case of "Motor alarm", the LED blinks green, then yellow.

Table 6.2 Alarm indications [F7521F61, F7521F62]

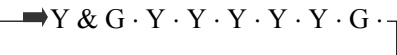
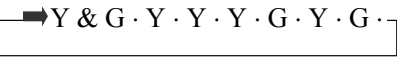
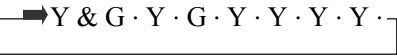
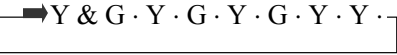
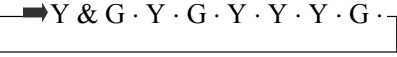
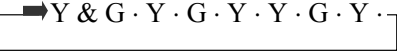
Failure	Alarm display (LED)	Description
Motor alarm		Motor rotation error
Laser alarm		Laser circuit error
ROM alarm		ROM check error
EEPROM alarm		EEPROM check error
Internal RAM alarm		RAM check error
External RAM alarm		RAM check error



Do not disassemble

Do not disassemble, change, or modify the unit.



Fire

If the unit generates unusual heat, smoke, smells or sounds, unplug it immediately. Do not attempt to repair the unit yourself, you may be injured.

CHAPTER 7 SCANNER SETTING

This Chapter describes the barcodes (i.e., Programming labels) used in setting up the F7521F Scanner. Although they appear to be normal barcodes they restricted to use in programming scanner functionality and will not be read while the scanner is in general operation mode (i.e., online mode).

All parameters described in this chapter can be set only during "Programming Mode"

Scanner Setting (Programming)

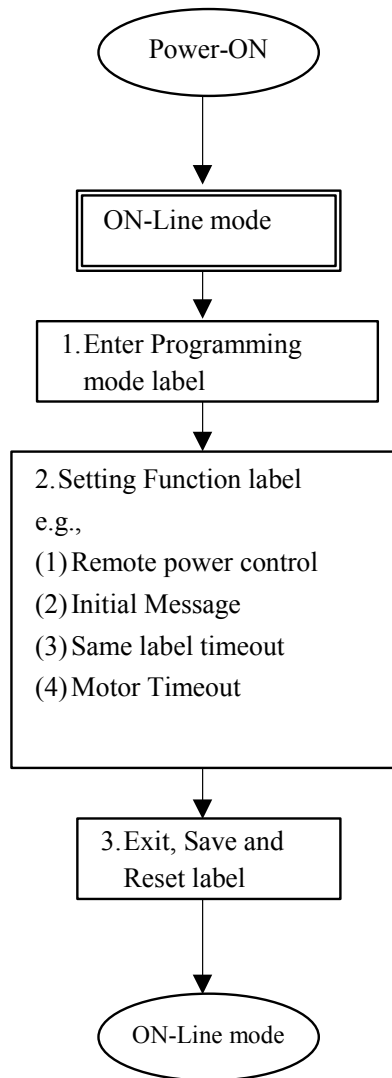

Note: see Scanner Programming Manual for a complete set of programming labels.

Setting labels

1. Enter Programming Mode

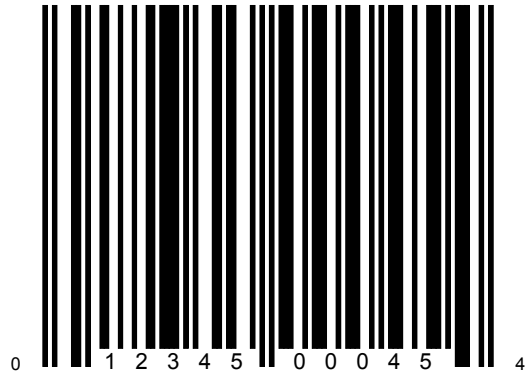

2. Setting Function

(1) Remote power control

Disable Remote power ON

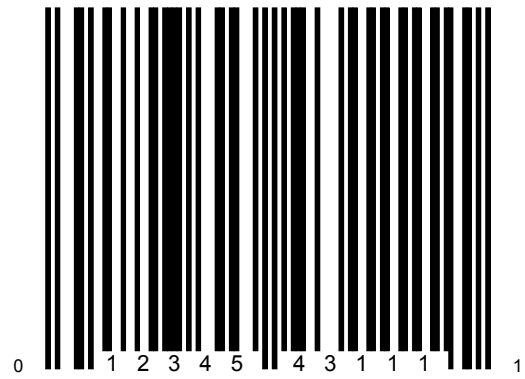

Enable Remote power ON

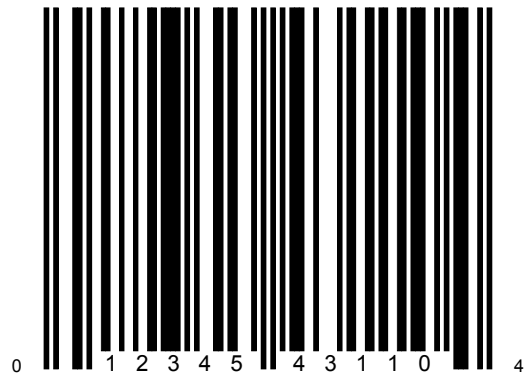

(2) Initial Message

Disable Initial Message

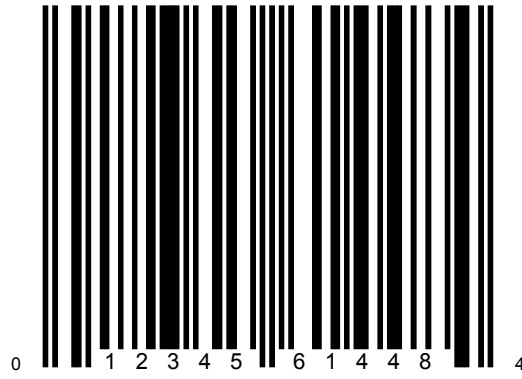

Enable Initial Message

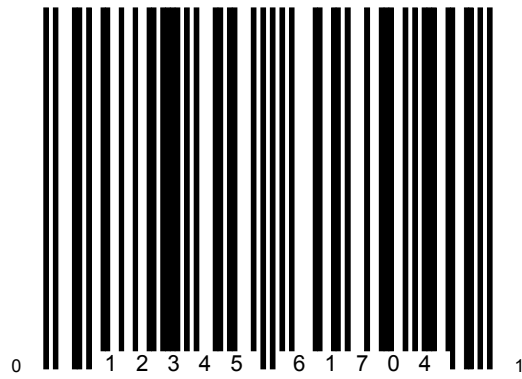

(3) Same label Timeout

Same label Timeout 400ms

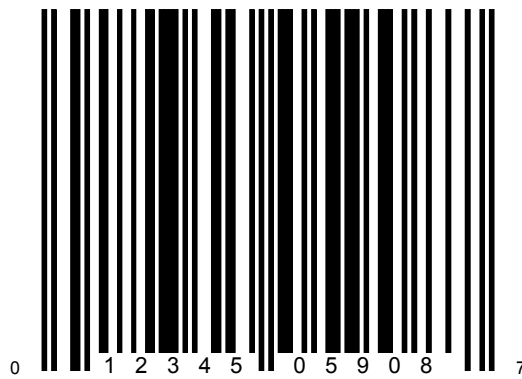

Same label Timeout 500ms

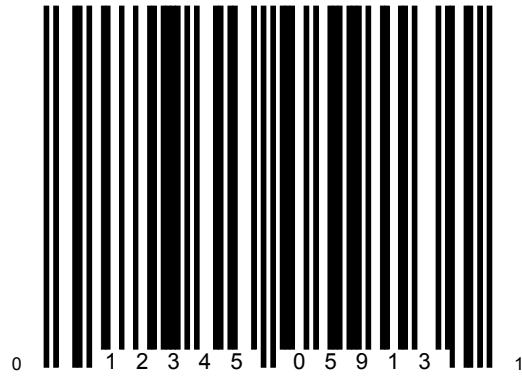

Same label Timeout 800ms

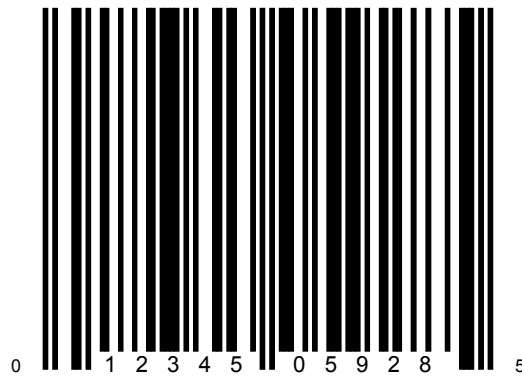

(4) Motor timeout

Motor Timeout 20 minutes

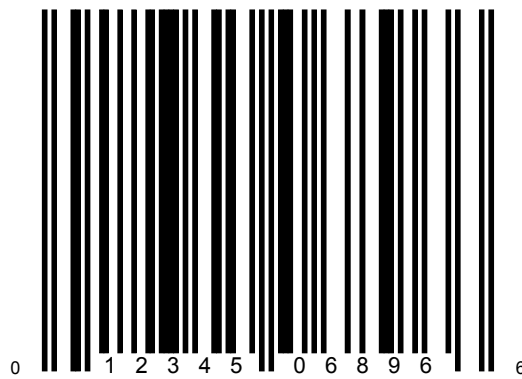

Motor Timeout 2 hours

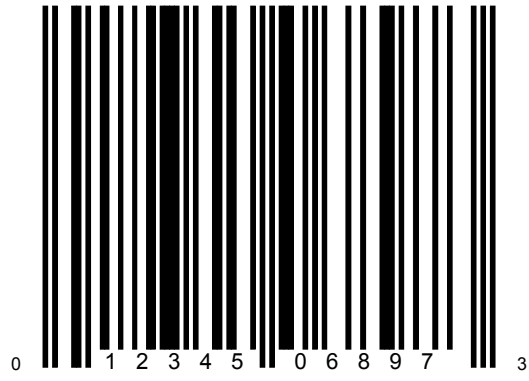

3. Exit with Saving (Return to ON-Line mode)

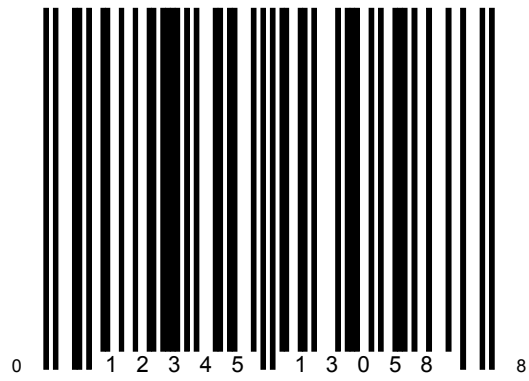

CHAPTER 8 SCALE

1. Cable connection

The F7521F supports two types of Scale Interface cable configurations.

(1) Single cable configuration

Scale and Scanner data communication to host terminal using a single (one) interface cable between the scanner and host terminal.

(2) Dual cable configuration

Scale and Scanner data communication to host terminal using dedicated (separate) scale and scanner interface cables between the scanner / scale and host terminal.

2. Install In Checkout counter

The F7521F Scanner/Scale must be level in the checkout counter and the Scale platter height should be adjusted relative to the checkout counter top (use the four leveling screws attached to the scale arms to adjust platter height).

3. Calibration and Inspection

The scale calibration procedure and scale accuracy test must be performed by a serviceman before placing the scale into sales use. (see Item 8 Calibration)

In some locations, government inspection is also required. In this case, a security seal may be placed on the unit by the Department of Weights and Measures representative.

4. Scale Operation

(1) Scanner operation panel

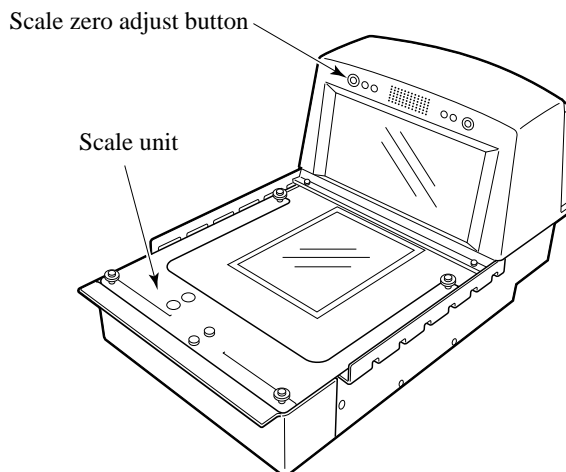

(2) Remote scale display

The remote scale display has a six digit character display. The display window also contains a Cursor to indicate "Zero" and "Net" weight.

Zero indicator: Illuminated when the scale is within the center of zero, +/- 0.4d

Net indicator: Not supported by this scale.

The remote scale display also provides two keys for scale zero and tare function.

Zero key: The zero button provides a scale zeroing function.

Tare key: The tare button is not supported by this scale.

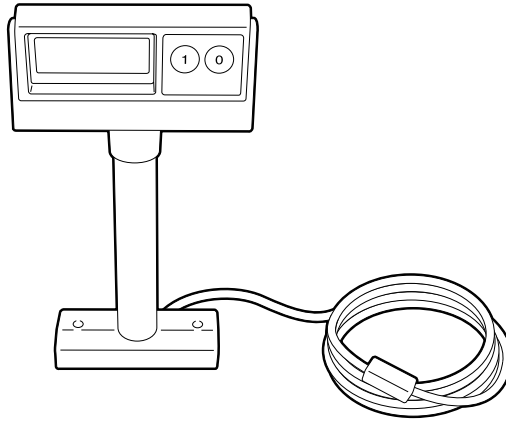

5. Scale setup

The scale function can be changed prior to the Calibration.

The following table describe Setup Function and Default setting.

Scale setup is performed the following process.

Refer to Programming Manual (CF6613-1) for Setup label, Function Items label(s) and Exit after Saving label.

Setup Function Items	Default setting
Cousor Indication	- <u>Indication</u> - Non Indication
Scale Capacity	- <u>15kg</u> - 30lb - 6kg
Expand Indication	- <u>Normal (0.xxx)</u> - Expand (0.xxxx)
Suspension (Note 1)	- <u>Light</u> - Medium - Heavy
Non zero timer (Note 1)	- <u>Disable</u> - 30 sec - 90 sec - 100 sec

Setup procedure :

- 1) Remove the scale platter.
- 2) Remove the bolt covering the calibration button. (see Fig.1)
- 3) While depressing the calibration button through bolt screw hole, scan the Set-up label.
 - Speaker will beep (long tone) and Green LED will light (on solid).
 - "Setup" will be displayed on remote scale display.
- 4) Scan Function Item label(s).
 - Speaker will beep (short tone).
 - Yellow LED will flash then Green LED will light (on solid).
 - If "Warble" tone from speaker, it means Program label value is already set in scale.
- 5) Scan "Exit after Saving" label.
 - Speaker will beep (long tone).
 - "Done" will be displayed in remote scale display.
 - Green LED will go off, and then Yellow LED will come on for 5 seconds.
 - Remote scale display will return to "0" weight indication.
- 6) Re-Install the bolt into the calibration button hole and replace the scale platter.

Note 1 : Only Enter Setup mode label reading is needed for the setting of Suspension and Non zero timer. Process 1), 2), and 6) are not necessary.

Note 2 : If the setup is failed :

- Speaker will beep and Yellow & Green LEDs will blink.
- "Abort" will be displayed on remote scale display.
- Power-up restart required to resume.

6. Diagnostics

No.	Error Condition	Code Displayed	Solution
1	Under zero	└────────┘	
2	Over capacity	┌────────┐	
3	Out of zero capture range	- - -	
4	Non-zero time out	_____	
5	EPROM/ROM check sum error	Err 1	
6	RAM error	Err 2	
7	EEPROM check sum err	Err 3	
8	Calibration required error	Err 4	

7. Scale capacity

Scale capacity	Increment	Load cell capacity	Resolution
30lb	0.01lb	45kg	3000d
15kg	0.005kg	45kg	3000e
6kg	0.002kg	22kg	3000e

8. Calibration

The scale calibration must be carried out with a calibrated set of test weights and in accordance with the local weights and measures requirements.

The scale calibrated using a 20lb or 10kg test weight appropriate to the avoirdupois/metric build capacity selected.

F7521F scanner scale should be on for at least 30 minutes prior to calibration.

To calibrate the scale, perform the following:

1. Remove the scale platter.
2. Remove the bolt covering the calibration button. (See Fig. 1)
3. Allow the F7521F scanner scale to warm up for at least 30 minutes.
4. While depressing the calibration button through bolt screw hole, scan the calibration label. (see Fig. 2)
 - Speaker will "beep" and Yellow LED will light.
 - If the scale display is connected, "Start" shown in it.
5. Replace the scale platter on the F7521F.
6. Depress the "0" zero adjust button on the F7521F. (not "0" button on the scale display)
 - Speaker beep and Green LED light.
 - If the scale display is connected, "Empty" shown in it.

7. Depress the "0" zero adjust button on the F7521F or scale display.
 Speaker beep and "Yellow and Green" or "Yellow" or "Green" LED blink.
 If the scale display connected, "ADD 20" or "ADD 10" or "ADD 4" shown in it.
8. Place the test weight on the scale platter according to the LED or Scale display.

See the following Table:

Test weight value	LED condition	Scale display
20 lbs	Yellow & Green LED blink	ADD 20
10 kg	Yellow LED blink	ADD 10
4 kg	Green LED blink	ADD 4

9. Depress the "0" zero adjust button after settling.
 - Speaker will "beep" and Yellow & Green LED will light.
 - If the scale display is connected, "DONE" will be displayed
 - Remove the test weight from the scale platter within 10 seconds after Yellow & Green LED are lit or the scale display shows "DONE".

If the speaker beeps and Yellow & Green LED's blink and "ABORT" is displayed in the scale display, the scale calibration has failed.
 The scale unit should be replaced if calibration cannot be completed as required.
 Even if the scale unit is not replaced after calibration failed, depressing the zero adjust button will return the F7521F to normal operation mode for use as a scanner unit.
10. Depress "0" zero button, the scanner return to normal operation mode.
11. Remove the scale platter again.
 Re-Install the bolt into the calibration button hole and seal according to the local weight and measure requirements.
12. Replace the scale platter on the F7521F, the calibration has been completed successfully.

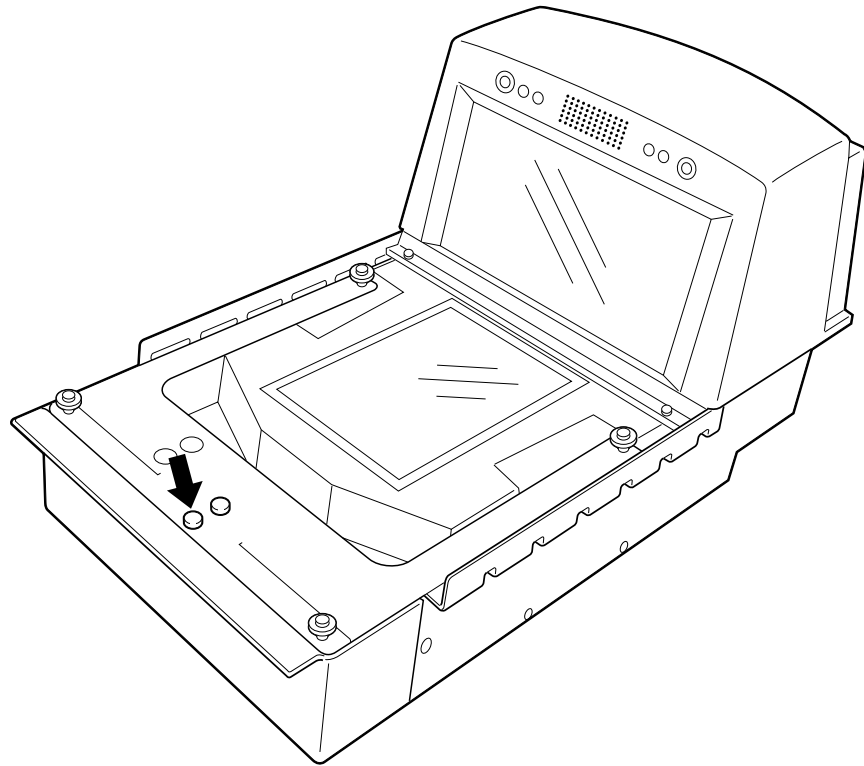

Fig.1 Location of bolt for cover the calibration button

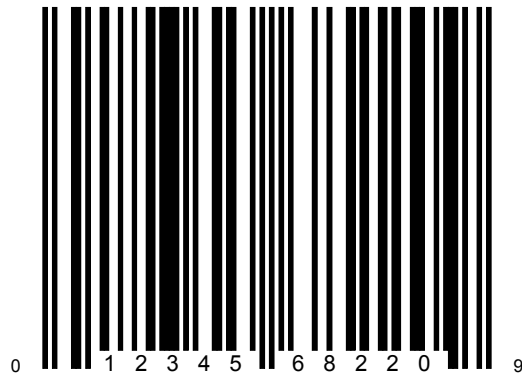

Fig.2 Calibration label

APPENDIX A

□ Installation specifications

Table A.1 Installation specifications

Item		Specification
Weight	Scanner	7kg/15.5lb
	Scanner Scale	10kg/22.1lb
Input power	Voltage	100 to 120 VAC 200 to 240 VAC
	Phase	Single-phase
	Frequency	50/60 Hz
Power consumption	Scanner	13W
	Scanner Scale	14W
Ambient condition	Device status	Operating
	Temperature	0 to 40°C/32° to 104°F
	Humidity	20 to 80%RH
Ambient light tolerance		5000 Lux or less
Sound noise (at 1m)		48dB

F7521F Scanner

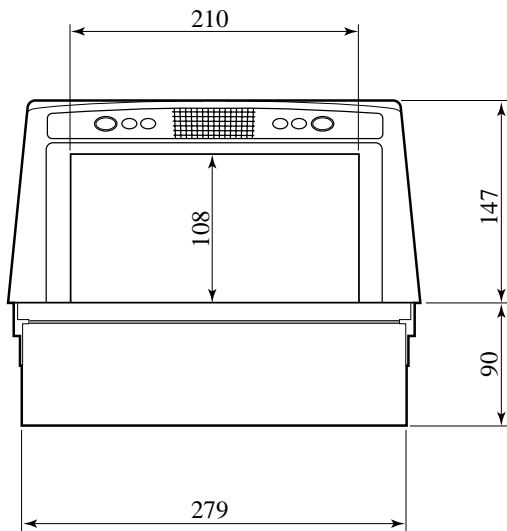
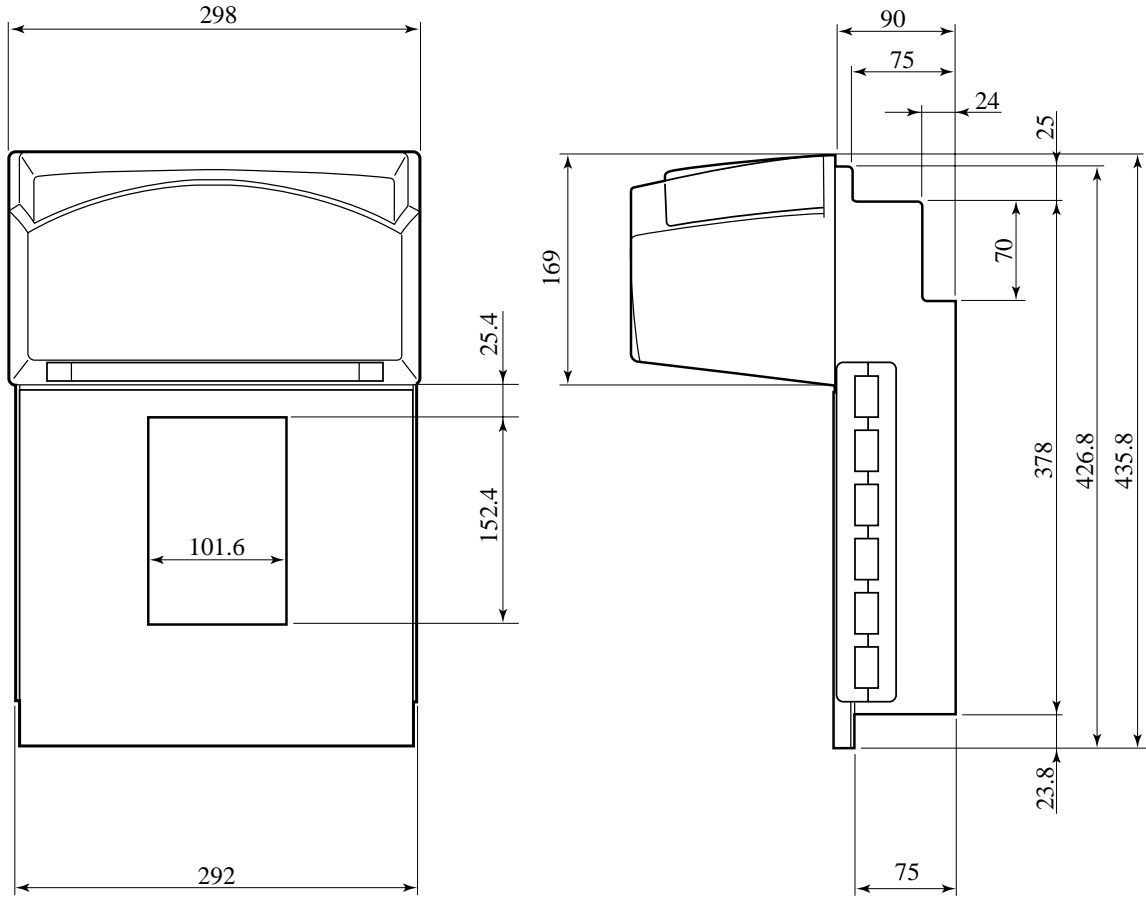

Note) Cutout in counter for scanner flange

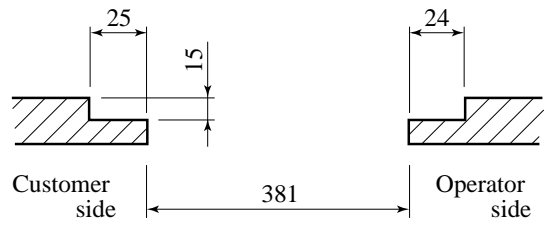

(unit = mm)

F7521F Scanner Scale

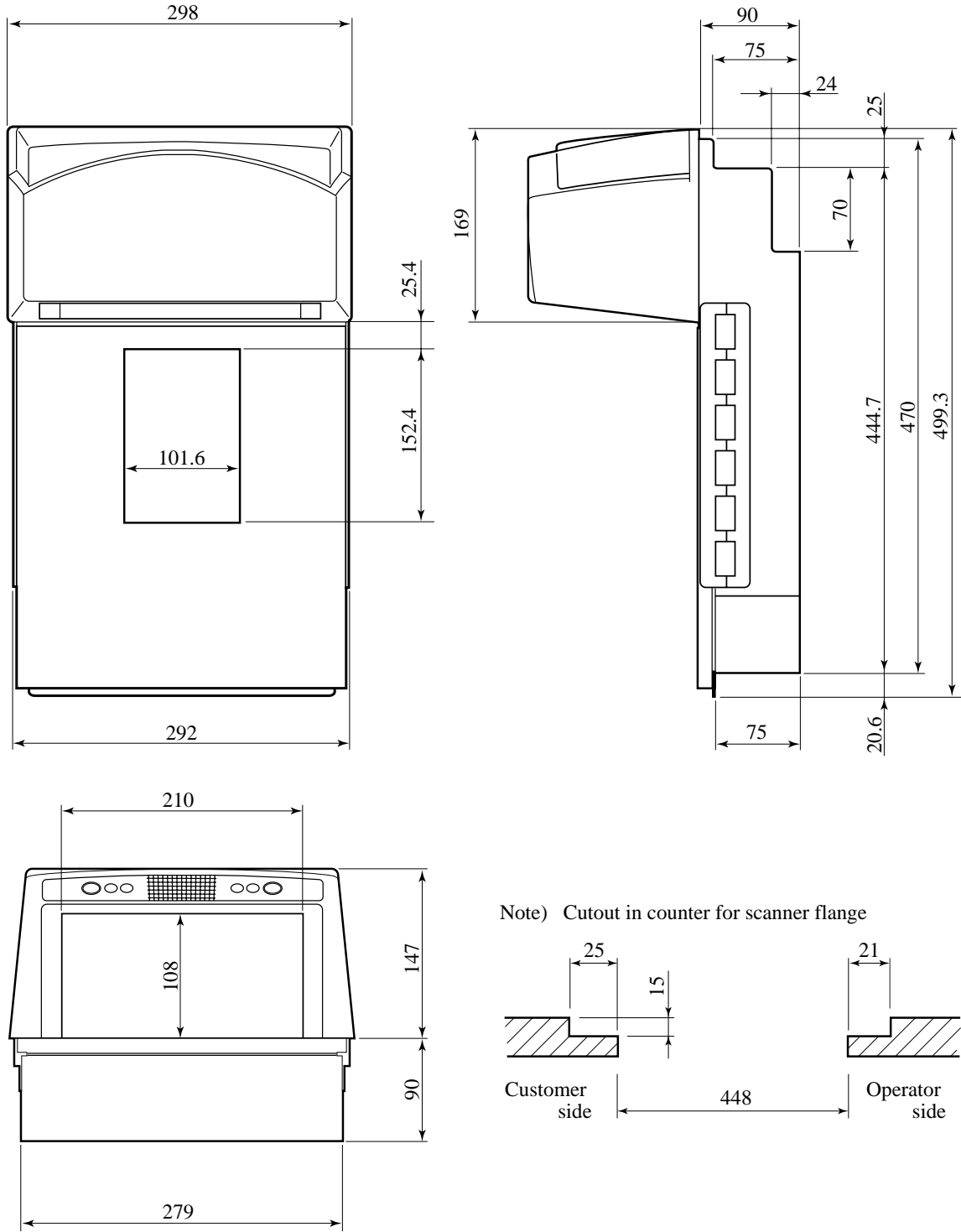

(unit = mm)

APPENDIX B

Power cable selection

Table B.1 Power cables

MODEL	All Models	All Models
Input Voltage	115-120 VAC	200-240 VAC
<*1> <*2> North America	Cord set Type SJT, No. 16 AWG 3-conductors (Single phase; 2-conductors & ground) with NEMA (5-15P) parallel blade Plug cap: Rated 15 A, 125 VAC.	
<*1> Europe		Cord set Connector: Rated 6 A, 250 VAC. Cable: <*2> 3 × 0.75 square mm Type H05VV-F Rated 7.5 A, 250 VAC.
<*1> Australia		Cord set Connector: Rated 6 A, 250 VAC Cable: <*2> 3 × 0.75 square mm Plug cap: Rated 7.5 A, 250 VAC.
<*1> U.K.		Cord set Connector: Rated 6 A, 250 VAC. Cable: <*2> BC O.C.3 × 0.75 square mm Plug cap: Rated 7.5 A, 250 VAC.

Notes:

*1: Be sure that the selected power supply cable has the approval of the appropriate safety agency for the country where the equipment will be used.

*2: The length of the above power supply cables shall be less than 4.5m.

AC adapter specification

Output rating : 12V, 2A
 Output connector : EIAJ RC-5320A
 (Type : P, Voltage classification : 4)



This manual uses recycled paper.