

SurePOS 500 Series

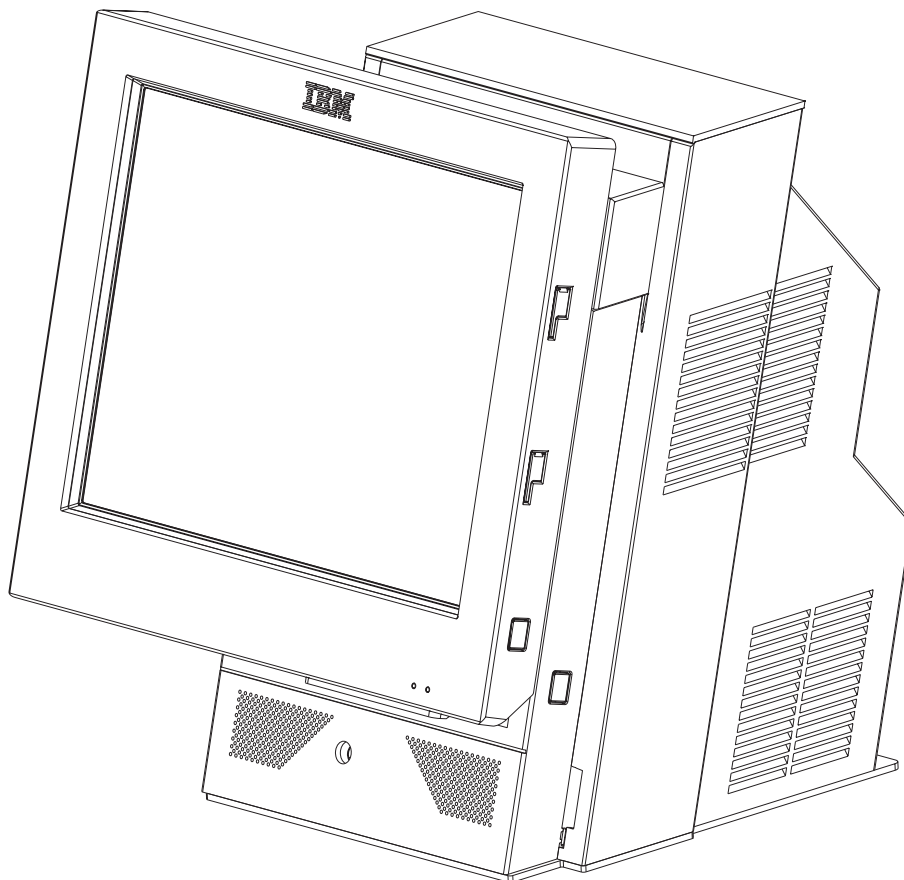

Hardware Service Guide for Models 545 and 565



SurePOS 500 Series



Hardware Service Guide for Models 545 and 565

Note

Before using this information and the product it supports, be sure to read "Safety and environmental notices" on page xi and the general information in Appendix D, "Notices," on page 131.

Second Edition (May 2007)

This edition applies to the IBM® SurePOS Machine Type 4846, Models 545 and 565 and to all subsequent releases and modifications until otherwise indicated in new editions.

Current versions of Retail Store Solutions documentation are available on the IBM Retail Store Solutions Web site at: www.ibm.com/solutions/retail/store/support. Click **Publications**.

Order publications through your IBM representative or the IBM branch office serving your locality. Publications are not stocked at the address given below.

A form for readers' comments is also provided at the back of this publication. If this form has been removed, address your comments to:

IBM Corporation
Retail Store Solutions Information Development
Department ZBDA
P.O. Box 12195
RESEARCH TRIANGLE PARK, NC 27709-9990
U.S.A.

When you send information to IBM, you grant IBM a nonexclusive right to use or distribute the information in any way it believes appropriate without incurring any obligation to you.

© **Copyright International Business Machines Corporation 2006, 2007. All rights reserved.**

US Government Users Restricted Rights – Use, duplication or disclosure restricted by GSA ADP Schedule Contract with IBM Corp.

Contents

Figures	vii
Tables	ix
Safety and environmental notices	xi
Safety Information	xi
Environmental notices and statements	xvii
End of life disposal	xvii
Battery disposal	xvii
Mercury-added statement	xviii
Magnetic stripe reader	xviii
Handling static-sensitive devices	xviii
About this guide	xix
Who should read this guide	xix
Related publications	xix
Publications accessibility	xix
Web sites	xix
Providing feedback	xix
Summary of changes	xxi
May, 2007	xxi
Chapter 1. Introducing the IBM SurePOS 500 Series Models 545 and 565	1
Models and features	2
Optional features	4
Connectors, power, and brightness controls	5
Supported operating systems	7
Understanding the display and operating system restrictions	7
Supported devices	9
System management	9
System management programs	9
Remote management	10
Compatible products	11
Locating the machine serial number	11
Chapter 2. Running diagnostics and troubleshooting	13
Using the CMOS Setup Utility	13
Using the Main window	13
Restoring the default CMOS settings	15
Clearing the CMOS settings	15
Real-time clock and CMOS	16
Configuring the COM (communication) ports	16
Using the IBM Diagnostics for POS Systems and Peripherals package	16
Supported memory keys	17
Updating the flash BIOS	17
Power interruption during flash BIOS update procedure	18
Repairing the flash BIOS	18
Diagnosing problems and troubleshooting	19
Researching the Knowledgebase	19
Preliminary checklist	19
Troubleshooting symptoms and actions	20
CMOS recovery	23

Chapter 3. Removing and replacing FRUs for the SurePOS 500 Models 545 and 565	
Opening and removing covers and assemblies	26
Handling static-sensitive devices	28
Modular service tools	29
Removing the covers	30
Front (or HDD) cover removal	30
Rear cover removal	31
Opening the I/O tailgate cover	32
Top cover removal	33
Hinge cover removal	34
Display tablet - removing and replacing	35
Display tablet cable – removing and replacing	36
Front bezel and LCD assembly - removing and replacing	37
Operator card - removing and replacing	39
Tablet hinge assembly – removing and replacing	40
Hard disk drive and bracket – removing and replacing	41
Hard disk drive fan and bracket – removing and replacing	43
Hard disk drive cables – removing and replacing	44
Cable tie bar – removing and replacing	45
Power supply – removing and replacing	46
Power supply latch arm – removing and replacing	47
Rear connector panel (tailgate) – removing and replacing	48
System board – removing and replacing	50
System-board jumper location and settings	52
System-board battery – removing and replacing	52
Processor fan/heatsink assembly - removing and replacing	54
Processor module – removing and replacing	55
Memory modules – removing and replacing	56
Memory modules and industry standards	57
Base plate – removing and replacing	58
Optional features	59
Magnetic stripe reader (MSR) – removing and replacing	59
MSR hole plug – removing and replacing	60
PC card blank – removing	60
PC card – removing and replacing	61
Video adapter card– removing and replacing	63
Speaker – removing and replacing	64
Integrated customer display – removing and replacing	66
Modular flash drive – removing and replacing	67
Chapter 4. Mounting the SurePOS 500 Models 545 and 565	69
Mounting the base plate on a countertop	71
Non-keyboard-integration tray mounting	74
Countertop with non-keyboard-integration tray mounting	74
Cash drawer	79
Keyboard-integration tray	84
Countertop and full-size cash drawer	84
Installing additional peripheral devices	93
Mounting a distributed customer display and APA display to a cash drawer	93
Installing IBM 4610 SureMark Models TF6 or TF7 printers	95
Appendix A. Field replaceable units	99
How to use the FRU catalog	99
Assembly 1: Models 545 and 565	100

Assembly 2: Countertop and cash drawer keyboard integration tray and filler panels	104
Assembly 3: Optional peripherals	106
Assembly 4: Countertop non-keyboard integration tray and filler panels	108
Assembly 5: Cash drawer non-keyboard integration tray and filler panels	110
Appendix B. Power cords	113
Appendix C. System specifications and planning information	115
Physical specifications and dimensions	115
Dimensions with trays	116
Dimensions of unit with 12-inch display	118
Dimensions of unit with 15-inch display	119
Dimensions of unit with 17-inch display	120
Power requirements and consumption	121
Power	121
Port power ratings	121
Connector-pin assignments	122
External connectors	122
Temperature, humidity, and altitude limits	130
Appendix D. Notices	131
Electronic emission notices	133
Federal Communications Commission (FCC) Statement	133
Industry Canada Class A Emission Compliance Statement	133
Avis de conformité aux normes d'Industrie Canada	133
European Union (EU) Mark of Conformity Statement	133
Germany	133
Australia / New Zealand	134
Japanese power line harmonics compliance statement	134
Japanese Voluntary Control Council for Interference (VCCI) Statement	134
Korean Communications Statement	135
Chinese Class A warning statement	135
Taiwanese Class A warning statement	135
Taiwan contact information	136
Taiwan recycle statement	136
Electrostatic Discharge (ESD)	136
Trademarks	137
Appendix E. Safety information	139
Safety Information-English	139
Safety Information-Arabic	141
Safety Information-Brazilian Portuguese	143
Safety Information-French	145
Safety Information-Hebrew	148
Safety Information-Korean	150
Safety Information-Italian	153
Safety Information-Spanish	156
Safety Information-German	158
Safety Information-Traditional Chinese	160
Glossary	163
Part number index	171
Index	173

Figures

1.	IBM SurePOS 500 Series configuration with optional features	1
2.	Tablet connectors	5
3.	Rear view of input/output available on all models	6
4.	Serial number location	11
5.	CMOS Setup Utility main window	14
6.	CMOS reset jumper J25	15
7.	Unlatching the front cover	30
8.	Removing the rear cover	31
9.	Opening the I/O tailgate cover	32
10.	Locating the top cover release latch	33
11.	Removing the hinge cover	34
12.	Removing the display tablet	35
13.	Removing the display tablet cable from the system board	36
14.	Disconnecting the touch cable and removing the front bezel	37
15.	View of L-shaped keyways	38
16.	Removing the operator card	39
17.	Removing the tablet hinge assembly	40
18.	HDD installation	41
19.	Removing the hard disk drive and bracket	42
20.	Removing the HDD fan and bracket	43
21.	Removing the cable tie bar	45
22.	Removing the power supply	46
23.	Removing the power supply latch arm	47
24.	Opening the I/O tailgate cover	48
25.	Removing the tailgate	49
26.	Removing the system board	50
27.	System board jumper location	52
28.	System-board battery	53
29.	Removing the processor fan/ heatsink assembly	54
30.	Memory socket location	56
31.	Memory module removal	57
32.	Removing the base plate	58
33.	Removing the MSR	59
34.	Removing the PC card adapter slot blank	61
35.	Removing a PC card adapter	62
36.	Video adapter card removal	63
37.	Removing the speaker thumbscrew	64
38.	Removing the speaker and speaker EMC shield	65
39.	Removing the integrated display	66
40.	Modular flash drive	67
41.	Base plate countertop dimensions	72
42.	Attaching the base foot to the countertop	73
43.	Countertop with non-keyboard-integration tray mounting	74
44.	Countertop integration tray pattern with display and countertop cutout on right side	75
45.	Detaching the fence from the tray	75
46.	Sliding the fence off of the integration tray	76
47.	Overview of integration tray, SurePOS 500, printer, and filler panels	77
48.	Connecting filler panels	78
49.	Attaching the integration tray to cash drawer	79
50.	Attaching a mounting plate to center of cash-drawer integration tray	80
51.	Attaching mounting plate to the cash drawer integration tray	81
52.	Attaching filler panels and the rear modesty cover	83
53.	Full-size keyboard-integration tray on a countertop	84

54. Countertop keyboard-integration tray assembly	86
55. Installing the keyboard-integration tray on a cash drawer	87
56. Installing the SurePOS 500 onto the integration tray	88
57. Installing the 4610 printer onto the integration tray	89
58. Installing the keyboard onto the integration tray	90
59. Attaching the distributed customer display cable	90
60. Installing the distributed customer display onto the integration tray	91
61. Attaching the distributed customer display cable	93
62. Attaching the distributed customer display to the system unit.	94
63. Installing the distributed customer display onto the keyboard integration tray	95
64. 4610 TF6 or TF7 printer connector locations.	96
65. Attaching and routing the cables to the printer.	97
66. Attaching the 4610 TF6 or TF7 printer mounting plate for a non-keyboard integration tray	97
67. 4610 TF6 or TF7 cable routing.	98
68. Dimensions of SurePOS Models 545 and 565 with retail tray	116
69. Dimensions of SurePOS Models 545 and 565 with counter top tray	117
70. SurePOS Models 545 and 565 with cash drawer tray	117
71. Dimensions of unit with 12-inch display	118
72. Dimensions of unit with 15-inch display	119

Tables

1.	4846 Models 545 and 565 summary	2
2.	E and P Models.	3
3.	Status indicators	3
4.	Controls and connectors	5
5.	Rear connectors	6
6.	SurePOS 500 Models 545 and 565 supported operating systems	7
7.	Operating system with display combinations and restrictions	8
8.	Supported video resolutions in Windows operating system	8
9.	Summary of tested and supported devices	9
10.	SurePOS 500 task information	19
11.	Symptoms and actions.	20
12.	Pictorial overview of common removal tasks.	26
13.	Service personnel tools	29
14.	System board jumper settings	52
15.	Mounting configurations	69
16.	Countertop integration tray legend	77
17.	Countertop integration tray legend	86
18.	4610 SureMark printer on a full-size keyboard-integration tray legend	89
19.	Power cord lengths and part numbers by country	113
20.	Height, weight and depth of the SurePOS 500 Models 545 and 565	115
21.	Weights of integrated, distributed displays and MSR	115
22.	SurePOS 500 Models 545 and 565 dimensions	116
23.	Input voltage, frequency.	121
24.	SurePOS 500 Series Models 545 and 565 power supply.	121
25.	Power consumption	121
26.	Port current ratings	122
27.	Speaker connector-pin assignments	122
28.	MSR connector-pin assignments	122
29.	USB port connector-pin assignments	124
30.	USB port connector-pin assignments	124
31.	Keyboard and mouse connector-pin assignments	124
32.	Keyboard and mouse connector-pin assignments	125
33.	Microphone connector-pin assignments	125
34.	Headphone connector-pin assignments	125
35.	RJ-45 connector-pin assignments	126
36.	Assignments for 15-pin serial connector	127
37.	Ethernet connector-pin assignments	127
38.	Assignment of external-video connector pins	128
39.	Assignment of cash drawer connector pins	129
40.	Assignment of integrated customer-display connector pins	129
41.	Temperature, humidity, altitude limits	130

Safety and environmental notices

Safety notices are printed throughout this book.

A *danger* notice indicates the presence of a hazard that has the potential of causing death or serious personal injury.

A *caution* notice indicates the presence of a hazard that has the potential of causing moderate or minor personal injury.

An *attention* notice indicates the possibility of damage to a program, device, system, or data.

A *note* provides important tips, guidance, or advice.

Safety Information



Danger:

Before you begin to install this product, read the safety information in *IBM Safety Information - Read This First*, GA27-4004. This booklet describes safe procedures for cabling and plugging in electrical equipment.



Gevaar:

Voordat u begint met de installatie van dit produkt, moet u eerst de veiligheidsinstructies lezen in de brochure *Veiligheidsinstructies—Lees dit eerst*, GA27-4004. Hierin wordt beschreven hoe u elektrische apparatuur op een veilige manier moet bekabelen en aansluiten.



Perigo:

Antes de começar a instalar este produto, leia as informações de segurança contidas em *Informações Sobre Segurança—Leia Isto Primeiro*, GA27-4004. Esse folheto descreve procedimentos de segurança para a instalação de cabos e conexões em equipamentos elétricos.



Fare!

Før du installerer dette produkt, skal du læse sikkerhedsforskrifterne i *Sikkerhedsforskrifter—Læs dette først GA27-4004*. Vejledningen beskriver den fremgangsmåde, du skal bruge ved tilslutning af kabler og udstyr.



Gevaar

Voordat u begint met het installeren van dit produkt, dient u eerst de veiligheidsrichtlijnen te lezen die zijn vermeld in de publikatie *IBM Safety Information — Read This First, GA27-4004*. In dit boekje vindt u veilige procedures voor het aansluiten van elektrische apparatuur.



VAARA

Ennen kuin aloitat tämän tuotteen asennuksen, lue julkaisussa *Turvaohjeet—Luetämä ensin, GA27-4004*, olevat turvaohjeet. Tässä kirjassessa on ohjeet siitä, miten sähkölaitteet kaapeloidaan ja kytketään turvallisesti.



Danger

Avant d'installer le présent produit, consultez le livret *Informations pour la sécurité—Lisez-moi d'abord, GA27-4004*, qui décrit les procédures à respecter pour effectuer les opérations de câblage et brancher les équipements électriques en toute sécurité.



Vorsicht

Bevor mit der Installation des Produktes begonnen wird, die Sicherheitshinweise in *Sicherheitsinformationen—Bitte zuerst lesen*, IBM Form GA27–4004. Diese Veröffentlichung beschreibt die Sicherheitsvorkehrungen für das Verkabeln und Anschließen elektrischer Geräte.



Vigyázat

Mielőtt megkezdi a berendezés üzembe helyezését, olvassa el a *IBM Safety Information — Read This First*, GA27–4004 könyvecskében leírt biztonsági információkat. Ez a könyv leírja, milyen biztonsági intézkedéseket kell megtenni az elektromos berendezés huzalozásakor illetve csatlakoztatásakor.



Pericolo

prima di iniziare l'installazione di questo prodotto, leggere le informazioni relative alla sicurezza riportate nell'opuscolo *Informazioni di sicurezza—Prime informazioni da leggere* in cui sono descritte le procedure per il cablaggio ed il collegamento di apparecchiature elettriche.



Fare

Før du begynner å installere dette produktet, må du lese sikkerhetsinformasjonen i *Sikkerhetsinformasjon—Les dette først*, GA27–4004 som beskriver sikkerhetsrutinene for kabling og tilkobling av elektrisk utstyr.



Perigo

Antes de iniciar a instalação deste produto, leia as informações de segurança *Informações de Segurança—Leia Primeiro*, GA27-4004. Este documento descreve como efectuar, de um modo seguro, as ligações eléctricas dos equipamentos.



Peligro

Antes de empezar a instalar este producto, lea la información de seguridad en *Información de Seguridad—Lea Esto Primero*, GA27-4004. Este documento describe los procedimientos de seguridad para cablear y enchufar equipos eléctricos.



Varning—livsfara

Innan du börjar installera den här produkten bör du läsa säkerhetsinformationen i dokumentet *Säkerhetsföreskrifter—Läs detta först*, GA27-4004. Där beskrivs hur du på ett säkert sätt ansluter elektrisk utrustning.

危險：安裝本產品之前，請先閱讀
"IBM Safety Information--Read
This First" GA27-4004 手冊中所提
供的安全注意事項。這本手冊將會說明
使用電器設備的纜線及電源的安全程序。

Opasnost: Prije nego što počnete sa instalacijom produkta,
pročitajte naputak o pravilima o sigurnom rukovanju u
Upozorenje: Pravila o sigurnom rukovanju - Prvo pročitaj ovo,
GA27-4004. Ovaj privitak opisuje sigurnosne postupke za
priključivanje kabela i priključivanje na električno napajanje.

Upozornění: než zahájíte instalaci tohoto produktu, přečtěte si
nejprve bezpečnostní informace v pokynech „Bezpečnostní
informace“ č. GA27-4004. Tato brožurka popisuje bezpečnostní
opatření pro kabeláž a zapojení elektrického zařízení.

Κίνδυνος: Πριν ξεκινήσετε την εγκατάσταση αυτού του προϊόντος,
διαβάστε τις πληροφορίες ασφάλειας στο φυλλάδιο *IBM Safety
Information-Read this first, GA27-4004*. Στο φυλλάδιο αυτό
περιγράφονται οι ασφαλείς διαδικασίες για την καλωδίωση των
ηλεκτρικών συσκευών και τη σύνδεσή τους στην πρίζα.

危險：導入作業を開始する前に、安全に関する
小冊子 GA27-4004 の「最初にお読みください」
(Read This First) の項をお読みください。
この小冊子は、電気機器の安全な配線と接続の
手順について説明しています。

위험: 이 제품을 설치하기 전에 반드시
"주의: 안전 정보-시작하기 전에"
(GA27-4004) 에 있는 안전 정보를
읽으십시오.

סכנה : לפני שמתחילים בהתקנת מוצר זה, יש לקרוא את הוראות הבטיחות בחוברת
Caution: Safety Information - Read This First, GA27-4004
חוברת זו מתארת את הוראות הבטיחות לחיבור הכבלים ולחיבור לחשמל של ציוד חשמלי.

خطر: قبل عملية بدء تركيب هذا المنتج، قم بقراءة معلومات
الحمية الموجودة في التحذير: معلومات الحماية - Read This First
GA27-4004 . يقوم هذا الكتيب بوصف اجراءات الأمان
لتوصيل الأدوات الكهربائية بالكابلات والمقبس الكهربائي.

ОПАСНОСТ

Пред да почнете да го инсталирате овој продукт, прочитајте ја информацијата за безбедност:
"Предупредување: Информација за безбедност: Прочитајте го прво ова", GA27-4004.
Оваа брошура опишува безбедносни процедури за каблирање и вклучување на електрична опрема.

Uwaga:

Przed rozpoczęciem instalacji produktu należy zapoznać się z instrukcją: "IBM Safety Information - Read This First", GA27-4004.
Zawiera ona warunki bezpieczeństwa przy podłączaniu do sieci elektrycznej i eksploatacji.

ОСТОРОЖНО: Прежде чем устанавливать этот продукт, прочтите Инструкцию по технике безопасности в документе "Внимание: Инструкция по технике безопасности -- Прочестъ в первую очередь", GA27-4004. В этой брошюре описаны безопасные способы каблирования и подключения электрического оборудования.

Nebezpečenstvo: Pred inštaláciou výrobku si prečítajte bezpečnosté predpisy v
Výstraha: Bezpečnosté predpisy - Prečítaj ako prvé, GA27-4004. V tejto brožúrke sú opísané bezpečnosté postupy pre pripojenie elektrických zariadení.

Pozor: Preden začnete z instalacijo tega produkta preberite poglavje: "Opozorilo: Informacije o varnem rokovanju-preberi pred uporabo," GA27-4004. To poglavje opisuje pravilne postopke za kabliranje,

危險：

開始安裝此產品之前，請先閱讀安全資訊。

注意：

請先閱讀 - 安全資訊 GA27-4004

此冊子說明插接電器設備之電纜線的安全程序。

危險：

在开始安装本产品之前，请阅读
IBM Safety Information - Read This First,
GA27-4004 中的安全信息。
此手册描述了如何安全地连接和插拔电气设备。

Environmental notices and statements

This section covers product recycling and product disposal.

End of life disposal

This unit must be recycled or discarded according to applicable local and national regulations. IBM encourages owners of information technology (IT) equipment to responsibly recycle their equipment when it is no longer needed. IBM offers a variety of product return programs and services in several countries to assist equipment owners in recycling their IT products. Information on IBM product recycling offerings can be found on IBM's Internet site at <http://www.ibm.com/ibm/environment/products/prp.shtml>.



Notice: This mark applies only to countries within the European Union (EU) and Norway.

Appliances are labeled in accordance with European Directive 2002/96/EC concerning waste electrical and electronic equipment (WEEE). The Directive determines the framework for the return and recycling of used appliances as applicable throughout the European Union. This label is applied to various products to indicate that the product is not to be thrown away, but rather reclaimed upon end of life per this Directive.

In accordance with the European WEEE Directive, electrical and electronic equipment (EEE) is to be collected separately and to be reused, recycled, or recovered at end of life. Users of EEE with the WEEE marking per Annex IV of the WEEE Directive, as shown above, must not dispose of end of life EEE as unsorted municipal waste, but use the collection framework available to customers for the return, recycling, and recovery of WEEE. Customer participation is important to minimize any potential effects of EEE on the environment and human health due to the potential presence of hazardous substances in EEE. For proper collection and treatment, contact your local IBM representative.

Disposal of IT products should be in accordance with local ordinances and regulations.

Battery disposal

This unit contains batteries. Remove and discard these batteries, or recycle them, according to local regulations. Return IBM units as determined by service procedures.

Taiwanese battery recycling statement

Waste batteries, please recycle.



廢電池請回收

Mercury-added statement

The fluorescent lamp in the liquid crystal display contains mercury. Dispose of it as required by local ordinances and regulations.

Magnetic stripe reader

The electronic article surveillance (EAS) device that deactivates security tags should not be closer than 18 in. (46 cm.) to the nearest edge of the magnetic stripe reader (MSR).

Handling static-sensitive devices

Attention: Static electricity can damage electronic devices and your system. To avoid damage, keep static-sensitive devices in their static protective bags until you are ready to install them.

To reduce the possibility of electrostatic discharge, observe the following precautions:

- Limit your movement. Movement can cause static electricity to build up around you.
- Handle the device carefully, holding it by its edges or its frame.
- Do not touch solder joints, pins, or exposed printed circuitry.
- Do not leave the device where others can handle and possibly damage the device.
- While the device is still in its anti-static bag, touch it to an unpainted metal part of the system unit for at least 2 seconds. (This action removes static electricity from the package and from your body.)
- Remove the device from its package and install it directly into your system, without putting it down. If it is necessary to put the device down, place it onto its static-protective bag. (If your device is an adapter, place it component side up.) Do not place the device onto the cover of the system or onto a metal table.
- Take additional care when handling devices during cold weather because heating reduces indoor humidity and increases static electricity.

About this guide

This guide provides information necessary to repair and maintain the IBM SurePOS® 500 Series Machine Type 4846, Models 545 and 565.

Who should read this guide

This guide is for the IBM service representative to assist in maintaining and repairing the IBM SurePOS 500 Series Models 545 and 565.

Related publications

The SurePOS 500 Series library consists of the following publications:

- *IBM SurePOS 500 Series Planning, Installation, and Operation Guide for Models 545 and 565*, GA27-4330
This guide provides installation and setup information, including option installation procedures and problem determination information.
- *IBM SurePOS 500 Series Operating System Installation Guide for Models 545 and 565*, GA30-4132
This guide provides step-by-step information on installing the operating software for the product.
- *IBM Point of Sale Options and I/O Devices Service Guide*, GC30-9737
This guide describes the problem-determination and repair procedures for cash drawers, displays, keyboards, and options that are attached to IBM® SurePOS™ systems.
- *IBM Safety Information — Read This First*, GA27-4004
This document contains important safety information.

To access these publications:

1. Go to: www.ibm.com/solutions/retail/store/.
2. Select **Support**, then select **Publications**.

Publications accessibility

The soft-copy version of this guide and other related publications are accessibility-enabled.

Web sites

For the latest troubleshooting guidance and symptom-fix tip information, go to the IBM support Web site at: www.ibm.com/solutions/retail/store. Select **Knowledgebase**.

This site contains additional information that is gathered from field experience, and not available when this document was developed.

Providing feedback

Your feedback is important in helping IBM provide accurate and high-quality information.

You can use either of these ways to provide feedback:

- Go to <http://www.ibm.com/solutions/retail/store>. Click **Support**, then click **Publications**. Click the **publication comments** within the introductory text. Provide the requested information and your comments. Be sure to include the name and form number of the document in the [Publication ID] field.
- Print and complete the form at the end of this document. Return the form to IBM by mail or by giving it to an IBM representative.

If applicable, include a reference to the specific location of the text (for example, the page or table number) on which you are commenting.

Between major revisions of this document, there might be minor technical updates. The latest version of this document is available on the Retail Store Solutions Web site at www.ibm.com/solutions/retail/store/support/publications/.

Summary of changes

May, 2007

This update includes information for the 17-inch model, and the modular flash drive.

Chapter 1. Introducing the IBM SurePOS 500 Series Models 545 and 565

Models and features	2
Optional features	4
Connectors, power, and brightness controls	5
Supported operating systems	7
Understanding the display and operating system restrictions	7
Supported devices	9
System management	9
System management programs	9
Remote management	10
Compatible products	11
Locating the machine serial number	11

The IBM SurePOS 500 Series Models 545 and 565 (machine type 4846) enable you to provide fast, accurate customer service and to manage your restaurant or store efficiently. You can configure the SurePOS 500 Series systems to support a wide variety of both IBM and non-IBM input/output (I/O) devices – everything from standard serial-attached devices to the Universal Serial Bus (USB)-attached devices.

System resources and the operating system may limit the use of ports. Figure 1 shows a sample SurePOS 500 configuration.

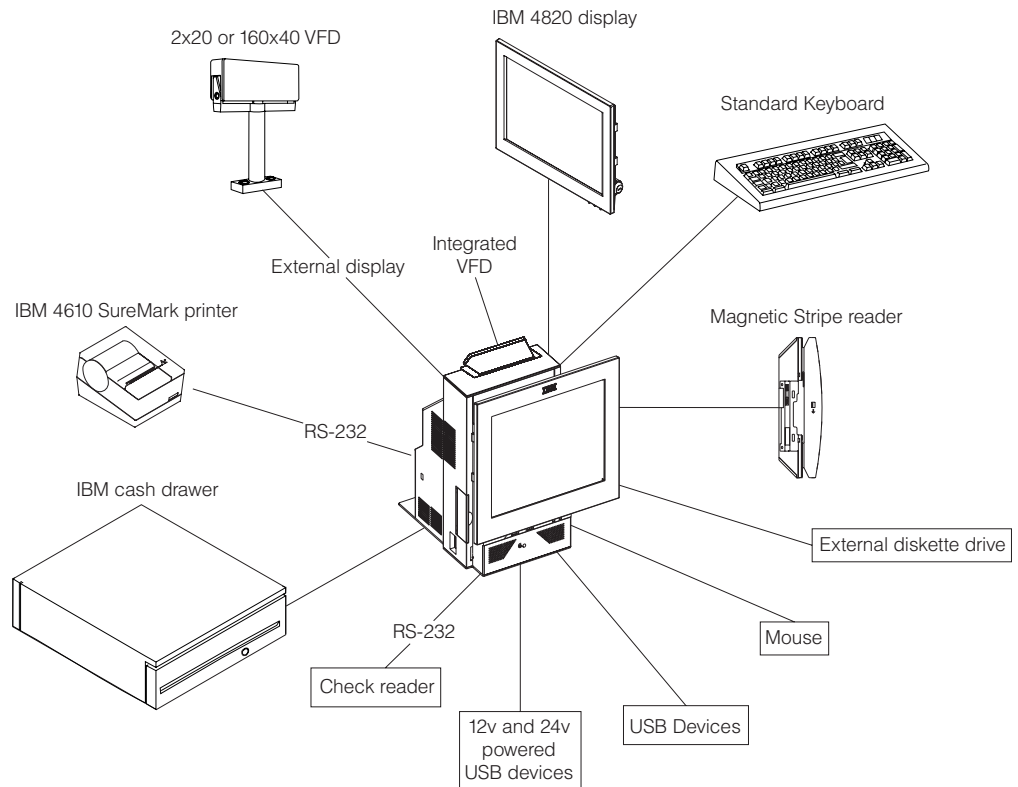

Figure 1. IBM SurePOS 500 Series configuration with optional features. Note: The location of the peripherals in this diagram is not an indication of the actual connector location.

Models and features

Table 1 and Table 2 on page 3 summarizes the SurePOS 500 models and features.



Table 1. 4846 Models 545 and 565 summary

Attribute	Model 545	Model 565
Processor and FSB speed	Intel 326 Celeron D: 2.53 GHz	
Chipset	Intel 915GV/ICH6	
BIOS	AwardBIOS	
Main memory	512 MB (standard) to 1 GB DDR2 DIMMs 2 slots (2 GB max)	
Video	Integrated 2D/3D Intel graphics controller for LCD/CRT; Dual independent video option for CRT (separate data from LCD) with dual video card	
LCD	One of the following: 800x600 12.1 in. TFT, High Bright 1024x768 15 in. TFT (2 bulb) 1280x1024 17 in. TFT (4 bulb)	
Touch	ELO Infra-red	
Audio	Not available	AC97 compliant, Codec; amplified stereo speakers
Mass storage	80 GB SATA II Modular Flash Drive	
LAN	Auto sensing 10BaseT/100 BaseTx Ethernet support	
Expansion	Not available	PC-Card slot (accommodates PC cards up to 119 mm long.)
I/O ports and connectors	7 standard USB (3 display tablet, 4 tower rear) Mouse (rear) Keyboard (rear) 1, 12V powered USB (rear) 1, 24V powered USB (rear) 2 cash drawer 3 unpowered RS-232 1 powered RS-232 (external customer display) Head phone (available on Model 565) Microphone (available on Model 565) RJ-45 Ethernet LAN External CRT	
I/O devices	External floppy (USB) MSR (3-track/JUCC) Integrated 2x20 Distributed 2x20 Distributed APA	
Indicators	Power HDD activity Ethernet See Table 3 on page 3 for the status indicator states.	
Controls	Power LCD brightness Volume (with speaker kit, available on Model 565)	

Table 2. E and P Models

Model Number	Description
4846-E45	System unit Model 545, preloaded with the Windows XP Embedded for Point of Service (WEPOS)
4846-E65	System unit Model 565, preloaded with the Windows XP Embedded for Point of Service (WEPOS)
4846-P45	System unit Model 545 with 4610 Printer
4846-P65	System unit Model 565 with 4610 Printer

Table 3. Status indicators

Status/power indicator		<p>On: Logic working correctly. Source AC power present and within tolerance.</p> <p>Off: System board defective or power is off</p> <p>Blinking during POST: Logic malfunction or system in suspend mode</p>
HDD indicator		<p>On HDD is reading or writing</p> <p>Off: No HDD activity</p> <p>Blinking: HDD is reading or writing</p>
Ethernet		<p>Green Left LED states:</p> <ul style="list-style-type: none"> • Off - 10 Mbit mode • On - 100 Mbit <p>Right LED states</p> <ul style="list-style-type: none"> • Off - No link • On - Good link • Blinking - Network activity

Optional features

The following is a list of optional features available for the SurePOS 500:

- 4 GB modular flash drive (second drive only)
- Memory:
 - 512 MB DDR2 (standard)
 - 1 GB DDR2
 - 2 GB DDR2, (2 x 1 GB)
- Displays:
 - Integrated 2x20
 - Distributed 2x20
 - Distributed APA
 - 12-in, 17-in. LCD (15-in. is the standard feature)
- MSR:
 - 3-track
 - JUC
- Countertop/full-size cash drawer integration tray for printer and keyboard
- Countertop integration tray for single station printer, non-keyboard
- Wide cash drawer integration kit for single station printer, non-keyboard
- Cash drawer
- Compact A/N POS (CANPOS) KEYBOARD
- External USB floppy drive
- USB antenna cover (accommodates USB antennas up to 32mm X 101 mm; excluding the exposed connector)
- Side cover to accommodate PC Card antennas with lengths up to 119 mm

Connectors, power, and brightness controls

Figure 2 and Table 4 identifies the controls and tablet connectors.

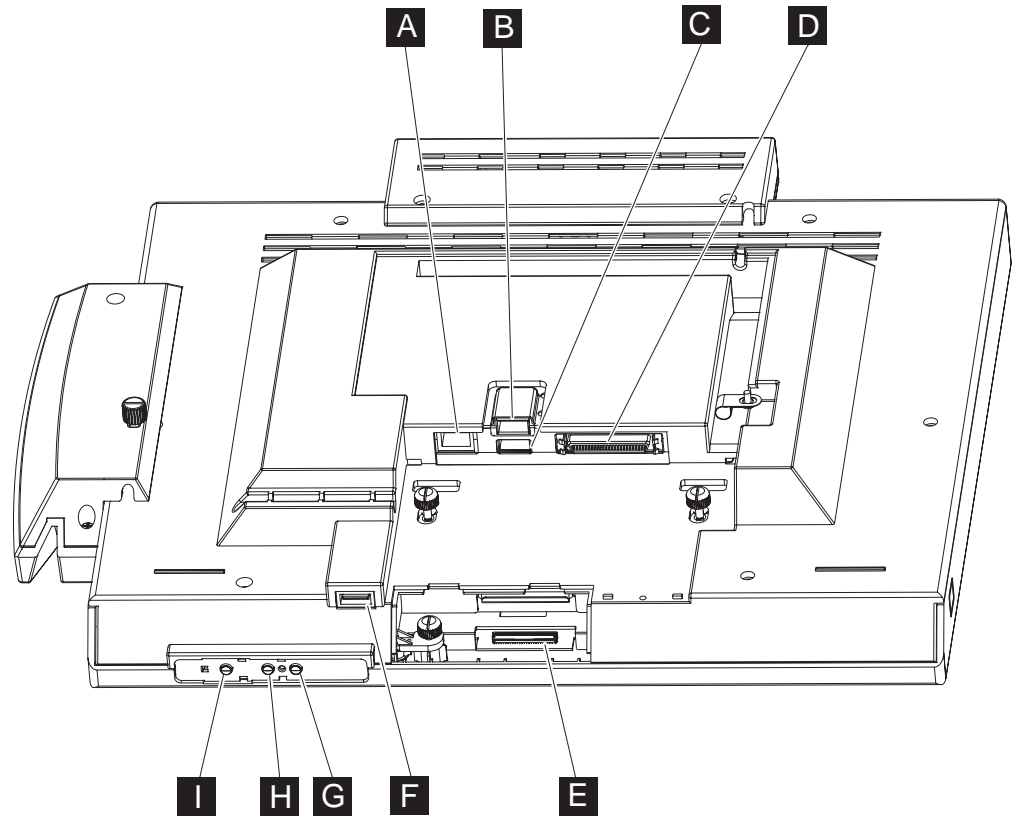

Figure 2. Tablet connectors

Table 4. Controls and connectors

Reference	Description
A	MSR port
B C F	USB connectors
D	Tablet cable connector
E	Touch cable connector (located behind door)
G H	LCD brightness controls (minus – and plus +)
I	Power button

Figure 3 on page 6 and Table 5 on page 6 identifies the rear connectors.

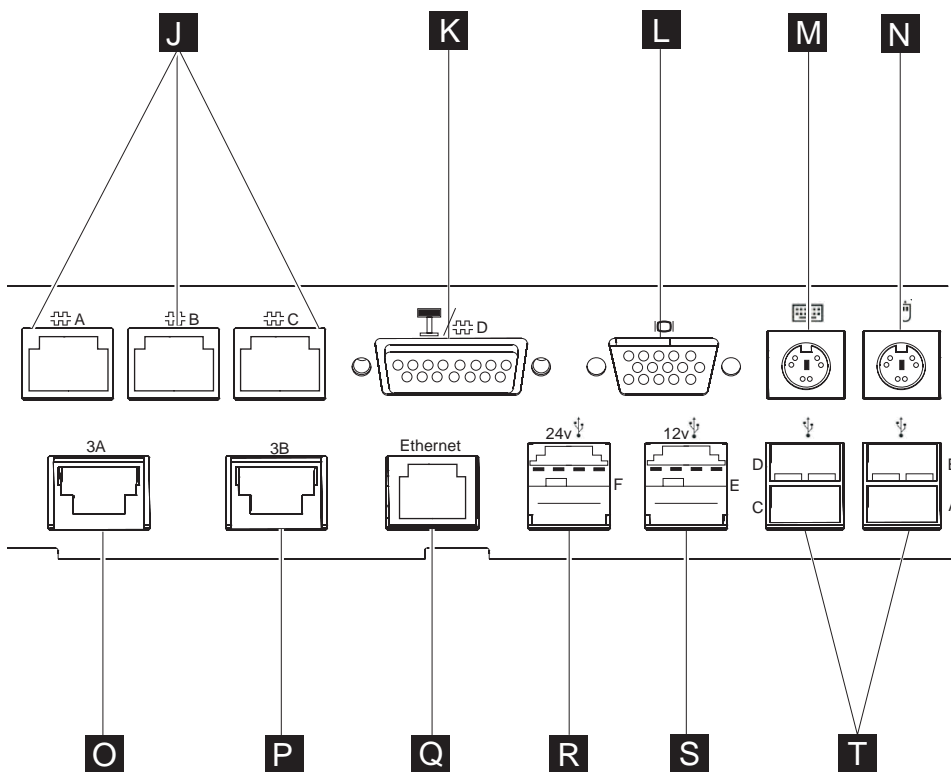

Figure 3. Rear view of input/output available on all models

Table 5. Rear connectors

Reference	Description	Icon
J	Serial ports (3), non-powered	
	12V serial	
L	VGA	
M	Keyboard	
N	Mouse	
O, P	Cash drawer connectors (2 each rated 24 V, 1.0 A 200 ms pulse)	3A, 3B
Q	Ethernet	
R	Powered 24V rated for 3A continuous	
S	Powered 12V	
T	USB 2.0 ports (4)	

Supported operating systems

Table 6 describes the operating system support:

Table 6. SurePOS 500 Models 545 and 565 supported operating systems

Supported operating system	Support for Point of Sale application drivers (MSRs, customer displays, cash drawers, tone)	Application Driver Notes
PC DOS 2000	Hardware direct interface only	Driver updates are required from previous SurePOS 500 models. MSR and Scanner in Wedge mode is not supported.
Windows 2000, XP Windows Embedded Point of Service (WEPOS) ¹ Power management via ACPI Notes: 1. Only DOS full screen mode supported due to touch screen alignment requirements. 2. Windows DBCS versions (Japanese/Korean/Chinese) supported.	IBM UPOS Drivers for Windows, Version 1.9.2 or later. (Includes JavaPOS drivers for Windows and OPOS drivers.)	

Note: ¹The standby and hibernation modes are not supported with WEPOS.

Understanding the display and operating system restrictions

The operating system, the display size, and any attached CRTs can affect the display resolution. The following definitions describe the terms and various display configurations:

Single A type of display configuration that supports only one display device.

Twin A type of display configuration that supports two display devices, each of which has the same content, resolution, and timings. Also referred to as Simultaneous mode.

Clone A type of display configuration that drives two display devices, each displaying the same content, but can have different resolutions and (independent) timings.

Dual Independent Head (DIH)

A type of display configuration that supports two displays with different content on each display device. Also referred to as an Extended Desktop.

The onboard LCD supports the following modes when using the indicated operating system:

- DOS: Single
- Windows 2000 and Windows XP: Clone (default), twin
- WEPOS: Clone (default), twin

The onboard LCD and one extra attached LCD:

- DOS: Single; the onboard LCD is primary
- Windows 2000 and Windows XP: Clone (default), twin, DIH
- WEPOS: Clone (default), twin, DIH

Table 7 summarizes the restrictions, if any, imposed by the operating system.

Table 7. Operating system with display combinations and restrictions

Display		DOS	Windows
Onboard LCD only	Image	Single ₁	Single
	Restrictions	None	
Onboard LCD + external display	Image	Single	Dual-same
	Restrictions	External display not supported	Media clips show on onboard LCD only; External display must be the same resolution as onboard LCD
Onboard LCD + Add-in video card	Image	Single, on board LCD	Dual-independent ₂
	Restrictions	None	Onboard LCD becomes secondary display when installing Windows
General	Restrictions	Touch on primary display only	None

1. Dual-same: same data on both displays; simultaneous mode
2. Dual-independent; different/independent data on both displays; extended desktop

Table 8. Supported video resolutions in Windows operating system

LCD size	Available video resolutions for onboard LCD
12 in.	640 x 480, 720 x 480, 800 x 600
15 in.	640 x 480, 720 x 480, 800 x 600, 960 x 540, 1024 x 768
17 in.	640 x 480, 720 x 480, 800 x 600, 960 x 540, 1024 x 768, 1152 x 864, 1280 x 720, 1280 x 768, 1280 x 960, 1280 x 1024

Supported devices

Table 9 summarizes the industry standard devices that have been tested with the product. Other industry devices may be supported using standard interfaces; however, no testing was performed to insure functionality in all aspects of operation.

Table 9. Summary of tested and supported devices

Port type	Supported device	Hot plug support (See note 1)
RS-232 (Serial)	<ul style="list-style-type: none"> 4610 TF6/TF7 single station thermal printer 4610-TG3, TG4, TG5 	Not supported
CRT (Video)	<ul style="list-style-type: none"> 4820-4FD/4FT with MSR option, USB 4820 - 1GD, 2GN, 2GD, 2GB 	Not supported
USB	<ul style="list-style-type: none"> 4610-GB3 4610-TG3/TG4/TG5 IBM USB floppy drive IBM USB keyboard IBM Memory key IBM 4685-S01/L0h handheld scanner 	Yes; however, USB not supported on DOS; powered USB ports is not supported.
Keyboard/Mouse	<ul style="list-style-type: none"> IBM PS/2 keyboard IBM mouse Retail CANPOS keyboard (See note 2.) 	Yes for USB devices No for PS/2 devices
PC Card	<ul style="list-style-type: none"> See the IBM web site (www.ibm.com/solutions/retail/store/) for tested devices. 	Yes
Headphone/microphone	<ul style="list-style-type: none"> IBM or equivalent 	Yes
Notes:		
1. Assumes device natively supports hot plugging and can be hot plugged with any operating system.		
2. CANPOS MSR option is mutually exclusive for SurePOS 500 Models 545 and 565.		
3. Some PCMCIA devices may require third party software support.		

System management

This section describes the types of system management available with the SurePOS 500.

System management programs

The SurePOS 500 Series supports the following system and power management programs:

Desktop Management Interface

The SurePOS 500 Series supports System Management BIOS (SMBIOS) v2.4, supporting a DMI-compliant agent such as Tivoli®. This allows access to low-level information. Examples of information that can be accessed are the BIOS level, processor type, speed, manufacturer, system-board information, and detailed memory information.

RDM (Remote Deployment Manager) and IBM Director.

RDM can install an OS and update BIOS remotely and probe machines for low-level information. IBM Director can remotely configure applications and operating systems, transfer files, and inventory workstations on a network.

APM APM consists of several layers of software that allow the operating system, applications, and BIOS to work together to reduce power consumption. APM is supported on DOS and Linux platforms.

Advanced Configuration and Power Interface

Advanced Configuration and Power Interface (ACPI) V1.0 defines a hardware and software interface and tables by which the operating system can alter the characteristics of the hardware-specific devices. ACPI is supported on Windows 2000 and Windows XP.

Power up on LAN

This feature enables the system to power on when it receives a specific frame over the local area network (LAN) through the 10/100-Mbps Ethernet feature. You can enable power up (wake) on LAN by enabling **Wake on LAN** in the CMOS Setup Utility program.

Power up (wake) on daily alarm

This feature enables the system to turn on at the same time every day. You can enable power up (wake) on daily alarm by enabling **Wake on Alarm** in the CMOS Setup Utility program.

RMA IBM Remote Management Agent is a component of IBM Store Integration Framework that simplifies the delivery of new consumer-facing devices in stores to support the delivery of superior service. For more information, see the Retail Store Solutions web site.

Remote management

The SurePOS 500 Models 545 and 565 supports remote system management over the network. The following functions are supported:

- Selectable startup sequence
- Update POST/BIOS from the network
- Ethernet
- Power up (wake) on LAN

Compatible products

You can use the following products with the SurePOS 500:

- 4610 SureMark Single Station Thermal Printer (RS-232 models)
- 4610 SureMark Printer
- 4820 SurePoint Solution Terminal
- IBM point-of-sale USB devices
- Original equipment manufacturer (OEM) USB devices
- OEM RS-232 Point of Sale devices (printers, 2x20, and others)
- OEM USB printers
- CRT/LCD displays
- IBM USB portable CD-ROM drive
- IBM USB 2.0 CD-RW/DVD-ROM drive
- TEAC USB CD-ROM drive

Locating the machine serial number

The serial number and model number (**A** in Figure 4) are located under the front cover/HDD cover. **B** points to the tablet size label.

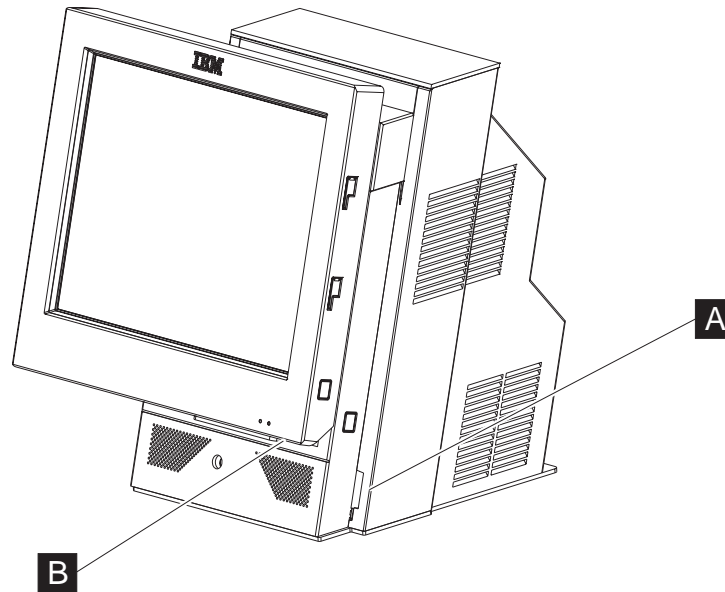

Figure 4. Serial number location

Chapter 2. Running diagnostics and troubleshooting

Using the CMOS Setup Utility	13
Using the Main window	13
Standard CMOS features	14
Advanced BIOS features	14
Integrated peripherals	14
Power Management	14
PnP/PCI Configurations.	14
PC Health Status	15
Load Defaults	15
Set Password	15
Restoring the default CMOS settings	15
Clearing the CMOS settings	15
Real-time clock and CMOS	16
Configuring the COM (communication) ports	16
Using the IBM Diagnostics for POS Systems and Peripherals package	16
Supported memory keys	17
Updating the flash BIOS	17
Power interruption during flash BIOS update procedure	18
Repairing the flash BIOS	18
Diagnosing problems and troubleshooting	19
Researching the Knowledgebase	19
Preliminary checklist	19
Troubleshooting symptoms and actions	20
CMOS recovery	23

Using the CMOS Setup Utility

Follow these steps to start the CMOS Setup Utility:

1. Switch the power ON.
2. Press **Del** during POST when prompted, or **tap the touch screen two times**.
Use the keys listed in the legend bar at the bottom of the screen to make your selections or exit from the current menu. The help window on the right side of each menu displays the online help information for the currently selected item.

Figure 5 on page 14 is an example of the initial panel that is displayed in the CMOS Setup Utility.

Using the Main window

Use the Main window (Figure 5 on page 14) to access the various features of the CMOS utility. The navigation tool bar is located at the bottom of the screen.

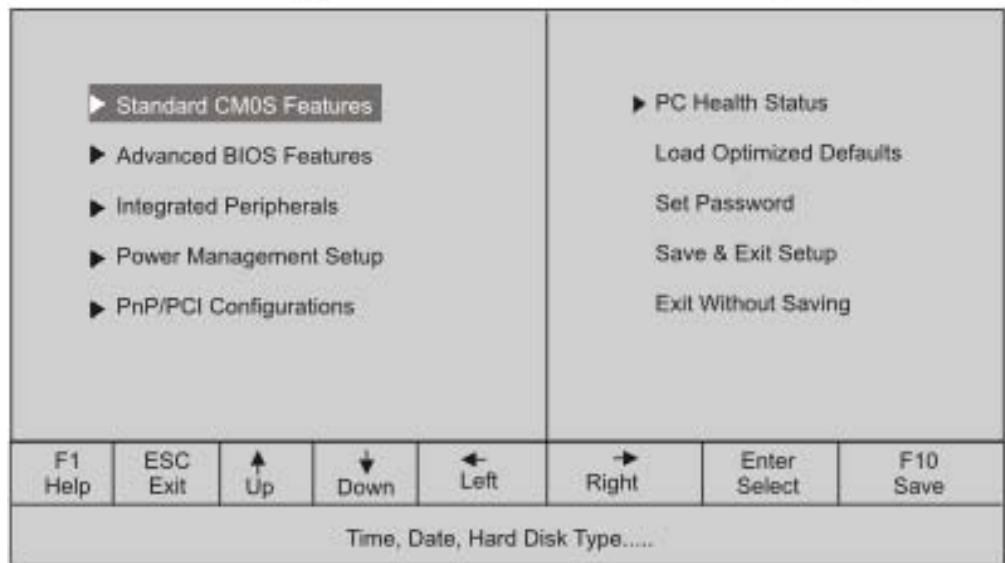

Figure 5. CMOS Setup Utility main window

Standard CMOS features

This menu provides basic functions, like setting the time and date. It also provides basic information, such as BIOS version, Ethernet MAC address, memory size, and machine serial number.

To change the date, month, and time using the CMOS Utility,

1. With the month entry highlighted (in red), touch the red numeric keyboard to indicate the current month. For example, enter 8 to change the month to Aug.
2. Touch enter. The correct month appears as text.
3. Using the displayed keyboard, enter the number of the month. For example, enter 8 for August, or 1 for January, and select Enter.

Advanced BIOS features

The Advanced BIOS window allows you to modify the POST and boot device settings, and set the keyboard features.

Integrated peripherals

Using this menu you can configure I/O devices, such as serial ports, Ethernet, parallel port, USB controller, and keyboard.

Power Management

Use the Power Management window to configure Wake on Ring, the power savings, hard disk time-out, video time-out, and other power settings.

Wake on Ring: Use the Power Management Setup menu to enable the **Wake on Ring** feature. Wake on Ring allows a modem attached to Serial Port D to wake the system using **Ring Indicate**. Additionally, the tailgate card contains jumpers for ports A-C to optionally associate DSR (pin 1) to **Ring Indicate**.

PnP/PCI Configurations

This option allows advanced functions for PCI configuration data.

PC Health Status

This is an information window that provides the CPU and system temperatures, voltages on the system board, and fan speed.

Load Defaults

This selection resets all options to their default configuration.

Set Password

Use the password options menu to set, change, or clear the system password.

Restoring the default CMOS settings

To restore CMOS default settings, select Load Optimized Settings from the main menu.

Clearing the CMOS settings

The SurePOS 500 uses battery-backed CMOS memory to store system settings. If the CMOS memory becomes corrupted and the system does not boot, you can restore the factory default values by following these steps:

1. Power off the system and disconnect the AC power.
2. Locate the CMOS reset jumper (J25) on the system board. See **A** in Figure 6.

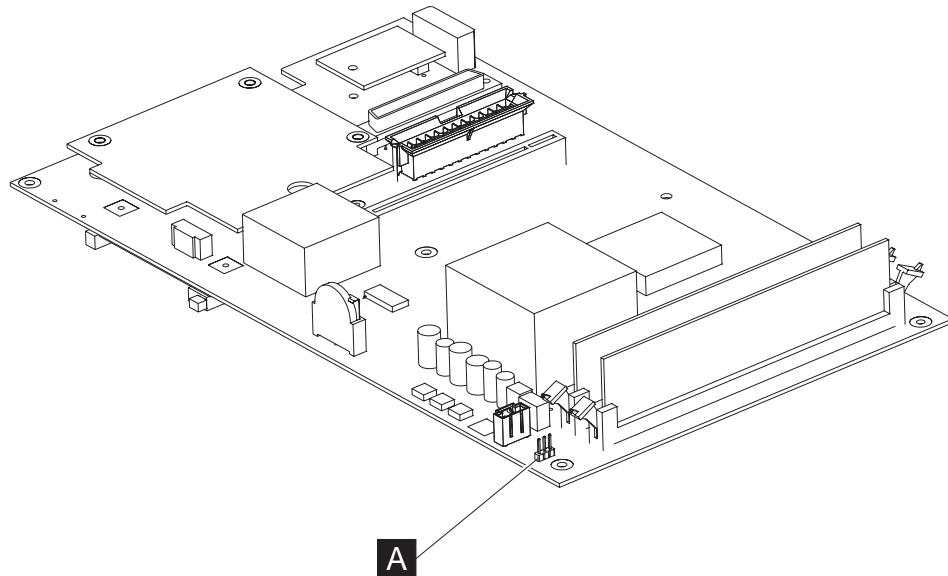

Figure 6. CMOS reset jumper J25

3. Remove the jumper, which is normally located on pins 1 and 2. (Pin 1 is located near the edge of the board, while pin 3 is closest to the memory sockets.)
4. Place the jumper on pins 2 and 3 and wait for 5 seconds. This resets the CMOS.
5. Return the jumper to pins 1 and 2.
6. Power ON the system.
7. When you restart the system after resetting the CMOS, the following error message is displayed:
CMOS checksum error - defaults loaded

To correct these errors, run the Setup Utility and select **Load Optimized Defaults**. This restores the CMOS defaults. After the defaults are restored, check the date and time, and set any other customer-specific settings that were modified before the CMOS was reset.

Real-time clock and CMOS

The real-time clock is a low-power clock that provides a time-of-day clock and a calendar. The clock settings are maintained by the battery when the power cord is removed. Use the CMOS Setup Utility to set the clock and calendar. See “Standard CMOS features” on page 14.

See “System-board battery – removing and replacing” on page 52 for the location of the battery.

Configuring the COM (communication) ports

Each COM port of the 4846 product uses a unique I/O address and IRQ. Some previous SurePOS 500 system units utilized PCI-based COM ports with a shared IRQ. The system BIOS configures the COM ports for use by the operating system; therefore, a separate driver is not required. (Serial port drivers from previous SurePOS 500 systems are not supported or required.)

Use the CMOS Setup Utility to configure or modify the COM ports, the default I/O address and the IRQ. If you make modifications, ensure that each port uses a unique I/O and IRQ value. Using default values are highly recommended. The *IBM SurePOS 500 Series Operating System Installation Guide for Models 545 and 565* provides a list of port resources.

Using the IBM Diagnostics for POS Systems and Peripherals package

Diagnostics for the SurePOS 500 Models 545 and 565 are available on the IBM Diagnostics for POS Systems and Peripherals package. This package installs to a memory key (see “Supported memory keys” on page 17).

Note: The Diagnostics also supports IBM POS I/O on prior systems, if the BIOS supports booting from a memory key.

Locate the instructions for using this package in the README file. This package provides menu-driven tests and utilities that enable trained service technicians to configure and test the I/O devices. Locate and download the service program code from the IBM Retail Store Solutions Web site using the following steps:

1. Obtain a memory key. See “Supported memory keys” on page 17.
2. Access the IBM Retail Store Solutions Web site at: www.ibm.com/solutions/retail/store/support.
3. Select **Support** on the left side of the panel, then select **IBM SurePOS 500/600 Series**.
4. Next, select **SurePOS 500-xx5 Downloads**.
5. Download the update program to a temporary location on the PC’s hard-disk drive. Run the self-extracting program and respond to the messages that display. This program writes the updates and provides instructions on inserting the memory key.

6. If you have *not* previously changed the CMOS Utility settings, you can boot into the diagnostics using the USB memory key: Insert the USB memory key and power on the system. If you have previously changed the default settings, go to Step 7.
7. If you have changed the default settings of the CMOS Setup Utility, follow these steps:
 - a. Ensure that the Hard Disk is listed as the First Boot Device under **Advanced BIOS Features, Hard Disk Boot Priority**.
 - b. Power off the machine.
 - c. Plug the memory key into a USB port.
 - d. Power on the machine. The system BIOS recognizes the memory key and adds it to the lists displayed by the CMOS Setup Utility.
 - e. Open the CMOS Setup Utility settings. Ensure that your settings are as follows:
 - Under **Advanced BIOS Features, Hard Disk Boot Priority**, ensure that memory key is listed first.
 - Under **First Boot Device**, ensure that **Hard Disk** is listed first.
 - f. Save these settings and exit. The system will boot automatically using the memory key and the diagnostics program begins.

You have the option of using an attached keyboard, if available. The diagnostics program will ask you to accept the user license agreement. Click the **I Agree** button. You will be presented with a screen containing a selection menu for System Components, Point Of Sale Devices, and Utilities (for VPD, and others). Sub-menus are dynamically-tailored based upon your system—only tests available for your machine type are displayed.

Supported memory keys

The following memory keys are supported by the SurePOS 500 Models 545 and 565:

IBM USB 2.0 (256 MB)

- FRU: 41D9746

Go to www.ibm.com for details on this USB key.

PNY USB 2.0 (1 GB)

- Part number: P1886C53

Go to <http://www2.pny.com/homepage.aspx> for details on this USB key.

Updating the flash BIOS

Download the latest level of flash BIOS for the SurePOS 500 Models 545 and 565 by following the instructions for downloading the diagnostics.

1. Follow the steps described in “Using the IBM Diagnostics for POS Systems and Peripherals package” on page 16
2. Switch the system ON again. The system boots from the memory key, the flash BIOS update occurs.
3. Remove the memory key. The new BIOS update is on the system.

Note: The flash utility saves and restores your CMOS setting.

Power interruption during flash BIOS update procedure

If power is interrupted during the flash BIOS update procedure, the BIOS could become corrupted. Should this event occur, the system boots automatically from a backup copy of BIOS. To repair the corrupt version of BIOS and return to using the normal BIOS, repeat the steps to update the flash BIOS.

Repairing the flash BIOS

Two separate copies of POST/BIOS are maintained in separate flash modules. Should the primary copy become corrupt, the system automatically runs from the backup copy when rebooted. A POST message indicates when the backup copy is in use. When this happens, it is important to perform a Flash Update, in an attempt to repair the primary copy and preserve the backup functionality. If the primary is permanently damaged, the system runs normally, but without backup capability for the BIOS, and the POST message appears at each boot up.

Diagnosing problems and troubleshooting

A software error or a hardware failure can cause a problem with the system. The following topics contain problem analysis instructions to help you determine the cause of a problem and resolve it.

Table 10 describes the servicing task and the section that contains information supporting the task.

Table 10. SurePOS 500 task information

Task	Go to
Diagnosing a problem.	"Preliminary checklist."
Update the flash BIOS.	"Updating the flash BIOS" on page 17.
Run the CMOS Setup Utility.	"Using the CMOS Setup Utility" on page 13.
Using the service program.	"Using the IBM Diagnostics for POS Systems and Peripherals package" on page 16
Obtain the part number for the FRU.	Appendix A, "Field replaceable units," on page 99.
Remove or replace a field-replaceable unit (FRU).	Chapter 3, "Removing and replacing FRUs for the SurePOS 500 Models 545 and 565," on page 25.

Researching the Knowledgebase

You can determine if a product problem has been resolved. Just review the symptoms and fixes in the knowledge base at the IBM Retail Stores Solutions Web site.

1. Go to www.ibm.com/solutions/retail/store/.
2. Select **Support**.
3. Select IBM SurePOS 500/600 Series
4. Select **Knowledgebase Tips and FAQs**.

Preliminary checklist

When you power on the SurePOS 500, the system performs a power-on self-test (POST). When the power LED stops blinking, POST is complete. If multiple beeps occur, perform the following steps to diagnose the problem.

1. Ensure that all AC power is connected and observe the power light to make sure that it is lit.
2. Ensure that all cables and I/O devices are connected correctly and securely.
3. Make sure that you correctly adjust the brightness setting, using the controls at the bottom right side of the display.
4. Record any error messages or symptoms for troubleshooting.

If you do not observe a specific error indication, continue problem resolution at "Troubleshooting symptoms and actions" on page 20.

Notes:

1. For internal options and peripheral devices, you can use the diagnostic service program to help resolve problems.
2. For devices with separate test instructions, refer to those instructions when testing.

- When using application software, you may receive error messages that pertain to the software. Refer to the software manual for a description of those messages.

Troubleshooting symptoms and actions

If the SurePOS 500 system fails with no error message or beep code, see Table 11 to find problem symptoms and take the related action.

Note: Corrupted CMOS may cause unpredictable problems. Before exchanging the system board to resolve a problem, go to “Clearing the CMOS settings” on page 15 and reset CMOS. Oftentimes, a corrupted CMOS is the source of the trouble.

Table 11. Symptoms and actions

If the problem is...	Here's what to do.
No power light on the tower unit.	<ol style="list-style-type: none"> Ensure that the system unit is plugged into a working electrical outlet and replug the power cable at the power supply. Verify that the tablet display cable is plugged into the tablet. Verify that the button/LED card in the tablet is plugged in properly. Verify the power supply is properly installed. Replace the power supply. See “Power supply – removing and replacing” on page 46. Replace the system board. See “System board – removing and replacing” on page 50.
Operator display exhibits: Blank screen No cursor displayed Screen is unreadable Other display problems.	<ol style="list-style-type: none"> Adjust the brightness control at the bottom right side of the display. Ensure that the tablet display cable is securely connected. Switch the unit off and the power on. Run the operator display test using the diagnostic service program. Replace the LCD assembly. See “Front bezel and LCD assembly - removing and replacing” on page 37. Replace the system board. See “System board – removing and replacing” on page 50.
For details on cash drawer removal and replacement procedures, see the <i>IBM Point of Sale Options and I/O Devices Service Guide</i> , GC30-9737. Throughout this text, this book is referred to as the <i>I/O book</i> .	
Cash drawer does not open when cash drawer key is turned to the open position.	<ol style="list-style-type: none"> Replace the keylock insert if the lock does not turn with the key. See the <i>I/O book</i>. Gently pull the drawer open while holding the key turned to the open position to determine if the slide assembly is binding. Look for items that may cause binds, such as pens or paper clips. Replace the slide assembly if necessary. Replace the cam, pawl, and spring kit. Check for a bent actuator rod. Replace the actuator rod if necessary.
Cash drawer does not stay closed.	<ol style="list-style-type: none"> Make sure that the keylock is not bound in the open position. Replace the keylock if necessary. Replace the cam, pawl, and spring kit. Replace the latch and the sensor assembly card. Replace the cash drawer. Replace the system board. See “System board – removing and replacing” on page 50.

Table 11. Symptoms and actions (continued)

Cash drawer does not open or close smoothly, or appears to be binding.	<ol style="list-style-type: none"> 1. Look for items that could cause binding. Pens or paper clips trapped between the drawer and cover or the drawer and base could cause binding. 2. Compact drawer only: Remove the drawer and the rollers at the rear of the drawer and at the front of the base. Replace the rollers if necessary. 3. Determine if the slide assembly in the base is binding. Replace the slide assembly if necessary.
Cash drawer not opening	<ol style="list-style-type: none"> 1. Run the CMOS Setup Utility to make sure that IBM cash drawer setting is enabled. 2. Ensure that the cash drawer cable is securely connected. 3. Replace the cash drawer cable. 4. Replace the cash drawer latch assembly. 5. Replace the system board.
Cash drawer does not open when performing store transactions or running cash drawer tests, but it opens when the cash drawer key is turned to the open position.	<ol style="list-style-type: none"> 1. Replace the latch and the sensor assembly card. 2. Replace the cash drawer cable. 3. Replace the system board. See "System board – removing and replacing" on page 50.
The status displayed by the cash drawer tests does not match the physical status of the cash drawer being tested. For example, the test indicates that cash drawer A is closed when cash drawer A is actually open.	<ol style="list-style-type: none"> 1. Replace cable. 2. Replace the latch and the sensor assembly card. 3. Replace the system board. See "System board – removing and replacing" on page 50.
Magnetic stripe reader (MSR) not reading.	<ol style="list-style-type: none"> 1. Check the three-track MSR dip switch settings for either RS232 or keyboard interface. 2. Run the CMOS Setup Utility and check the setting in the MSR serial port. 3. Ensure that the MSR cable is securely connected. 4. Run the MSR test using the diagnostic service program. 5. Reset to factory defaults by pressing the Reset button with a paper clip. The MSR must be removed temporarily from the side of the tablet to access the reset button. Leave the MSR cable connected, and the unit powered ON when pressing the Reset button. 6. Replace the MSR. See "Magnetic stripe reader (MSR) – removing and replacing" on page 59.
Operator display backlight: dark, dim, or partially lit.	<ol style="list-style-type: none"> 1. Adjust the brightness using the button located on the front of the display. 2. Ensure tablet display cable is securely attached under display tablet and at system board. 3. Replace the LCD assembly, see "Front bezel and LCD assembly - removing and replacing" on page 37.
Touch screen not working.	<ol style="list-style-type: none"> 1. Ensure tablet display cable is securely attached under display tablet and at system board. 2. Run the touch screen test using the diagnostic service program. 3. Reinstall the touch driver. 4. Replace the front touch bezel assembly. See "Front bezel and LCD assembly - removing and replacing" on page 37. 5. Replace the system board. See "System board – removing and replacing" on page 50.

Table 11. Symptoms and actions (continued)

PS/2 keyboard does not work or only some keys work.	<ol style="list-style-type: none"> 1. Ensure that the keyboard cable is securely connected. 2. Move your fingers across the keys, making sure that no keys are stuck. 3. Ensure that you are on a window that allows typing. Some windows do not allow you to type on them. 4. Run the keyboard test from the diagnostics program. 5. Replace the keyboard.
Diskette drive does not work.	<ol style="list-style-type: none"> 1. Check the diskette drive cable connections. 2. Run the CMOS Setup Utility to make sure the diskette drive controller is enabled. 3. Ensure that the correct boot device is selected in the CMOS Setup Utility, which is USB-FDD. 4. Verify the hardware by attempting to load a bootable diskette. 5. If the drive will not boot with a bootable diskette, replace the drive and cable. 6. Replace the system board.
Audio is not working.	<ol style="list-style-type: none"> 1. Check the volume control. 2. Check the speaker cable connections. 3. Run CMOS Setup Utility to make sure the audio is enabled. 4. Replace the speaker. 5. Replace the system board.
Fan continues running after system has been powered Off.	This is normal operation with the power supplies.

Notes:

1. Some devices that attach to the system have test instructions. Refer to those instructions when testing those devices.
2. Record any error messages or symptoms for future reference.
3. When using application programs, you may receive error messages that pertain to the application software. See the application program manual for a description of those messages.

CMOS recovery

If the CMOS memory becomes corrupted and the system does not boot, restore the factory default values by following the procedure described in “Clearing the CMOS settings” on page 15.

Always reset CMOS (as described at “Restoring the default CMOS settings” on page 15) before replacing a system board to resolve a problem. This practice allows you to determine if a corrupted CMOS is the source of the trouble. A corrupted CMOS can cause unpredictable problems.

Chapter 3. Removing and replacing FRUs for the SurePOS 500 Models 545 and 565

Opening and removing covers and assemblies	26
Handling static-sensitive devices	28
Modular service tools	29
Removing the covers	30
Front (or HDD) cover removal	30
Rear cover removal	31
Opening the I/O tailgate cover	32
Top cover removal	33
Hinge cover removal	34
Display tablet - removing and replacing	35
Display tablet cable – removing and replacing	36
Front bezel and LCD assembly - removing and replacing	37
Operator card - removing and replacing	39
Tablet hinge assembly – removing and replacing	40
Hard disk drive and bracket – removing and replacing	41
Hard disk drive fan and bracket – removing and replacing	43
Hard disk drive cables – removing and replacing	44
Cable tie bar – removing and replacing	45
Power supply – removing and replacing	46
Power supply latch arm – removing and replacing	47
Rear connector panel (tailgate) – removing and replacing	48
System board – removing and replacing	50
System-board jumper location and settings	52
System-board battery – removing and replacing	52
Processor fan/heatsink assembly - removing and replacing	54
Processor module – removing and replacing	55
Memory modules – removing and replacing	56
Memory modules and industry standards	57
Base plate – removing and replacing	58
Optional features	59
Magnetic stripe reader (MSR) – removing and replacing	59
MSR hole plug – removing and replacing	60
PC card blank – removing	60
PC card – removing and replacing	61
Video adapter card– removing and replacing	63
Speaker – removing and replacing	64
Integrated customer display – removing and replacing	66
Modular flash drive – removing and replacing	67

This section contains the FRU removal and replacement procedures for all SurePOS 500 Models 545 and 565 models (4846). Some procedures are for features that are not available on all models.

Notes:

1. Before you perform any removal and replacement procedures, see the sections entitled “Safety Information” on page xi and “Handling static-sensitive devices” on page 28.
2. The machine serial number for the 4846 is located on the lower right, front frame. See Figure 4 on page 11.
3. Switch OFF the power to the SurePOS 500. Unplug the power cord from the external power source.

Opening and removing covers and assemblies

The SurePOS 500 Series Models 545 and 565 is designed for modular servicing and installation. Table 12 shows the progression and ease of some common removals.

Table 12. Pictorial overview of common removal tasks





	Task:	Section with complete details:
	Opening the rear cover	"Rear cover removal" on page 31
	Removing the power supply	"Power supply – removing and replacing" on page 46
	Opening the tailgate	"Rear connector panel (tailgate) – removing and replacing" on page 48
	Removing the tailgate	

Table 12. Pictorial overview of common removal tasks (continued)





	Task:	Section with complete details:
	<p>Removing the top cover</p>	<p>"Top cover removal" on page 33</p>
	<p>Removing the system board</p>	<p>"System board – removing and replacing" on page 50</p>
	<p>Opening the front cover</p>	<p>"Front (or HDD) cover removal" on page 30</p>
	<p>Removing the hard-disk drive</p>	<p>"Hard disk drive and bracket – removing and replacing" on page 41</p>

Table 12. Pictorial overview of common removal tasks (continued)

	Task:	Section with complete details:
	<p>Opening the touch-cable cover</p>	<p>"Front bezel and LCD assembly - removing and replacing" on page 37</p>
	<p>Removing the front bezel</p>	

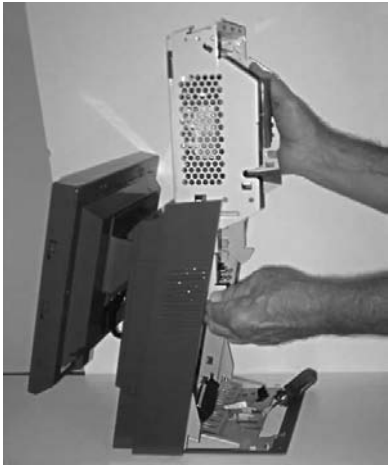
Note: These pictures represent only some of the common component removals.

Handling static-sensitive devices

Attention: Static electricity can damage electronic devices and your system. To avoid damage, keep static-sensitive devices in their static protective bags until you are ready to install them.

To reduce the possibility of electrostatic discharge, observe the following precautions:

- Limit your movement. Movement can cause static electricity to build up around you.
- Handle the device carefully, holding it by its edges or its frame.
- Do not touch solder joints, pins, or exposed printed circuitry.
- Do not leave the device where others can handle and possibly damage the device.
- While the device is contained in its anti-static bag, touch it and your finger to an unpainted metal part of the system unit for at least 2 seconds. (This action removes static electricity from the package and from your body.)
- Remove the device from its package and install it directly into your system, without putting it down. If it is necessary to put the device down, place it onto its static-protective bag. (If your device is an adapter, place it component side up.) Do not place the device onto the cover of the system or onto a metal table.
- Take additional care when handling devices during cold weather because heating reduces indoor humidity and increases static electricity.

Modular service tools

The SurePOS 500 Models 545 and 565 were designed for modular servicing and requires the minimum use of tools. However, some field replacement parts may require a tool. Table 13 lists the part number for tools that you may need for servicing.

Table 13. Service personnel tools

Description	Part Number	Units
Wrap plug, Ethernet	03N6070	1
Wrap plug, RS-232	72X8546	1
Adapter cable, RJ-45 to 9-pin conversion	40N5341	1

Removing the covers

This section describes how to remove the front, top, rear, tower, and side covers.

Front (or HDD) cover removal

1. Switch OFF the power to the SurePOS 500. Unplug the power cord from the external power source.
2. Tilt the top of the display tablet back.
3. Press inward on the buttons on each side of the front cover (see Figure 7), and pull the front cover/HDD cover slightly forward.

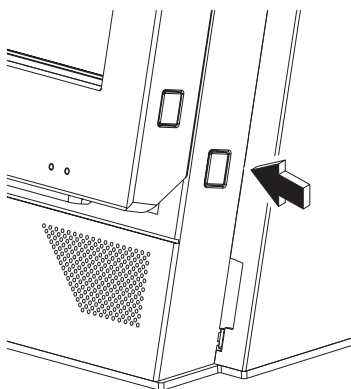

Figure 7. Unlatching the front cover

4. Lift the cover forward and away from the unit.
5. To replace, reverse these procedures.

Rear cover removal

1. Switch OFF the power to the SurePOS 500. Unplug the power cord from the external power source.
2. Facing the rear of the system, press down on the latch **A**, and rotate the top away as shown in Figure 8, and lift the rear cover away from the unit.

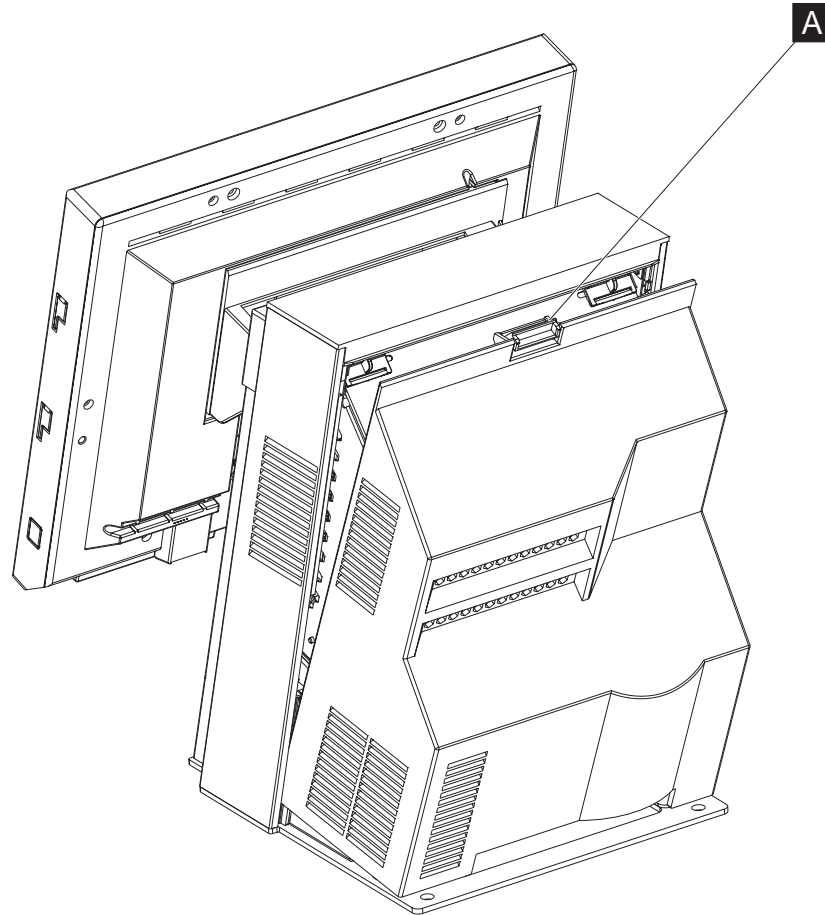

Figure 8. Removing the rear cover

3. To replace, reverse these procedures.

Opening the I/O tailgate cover

Open the I/O tailgate cover as follows:

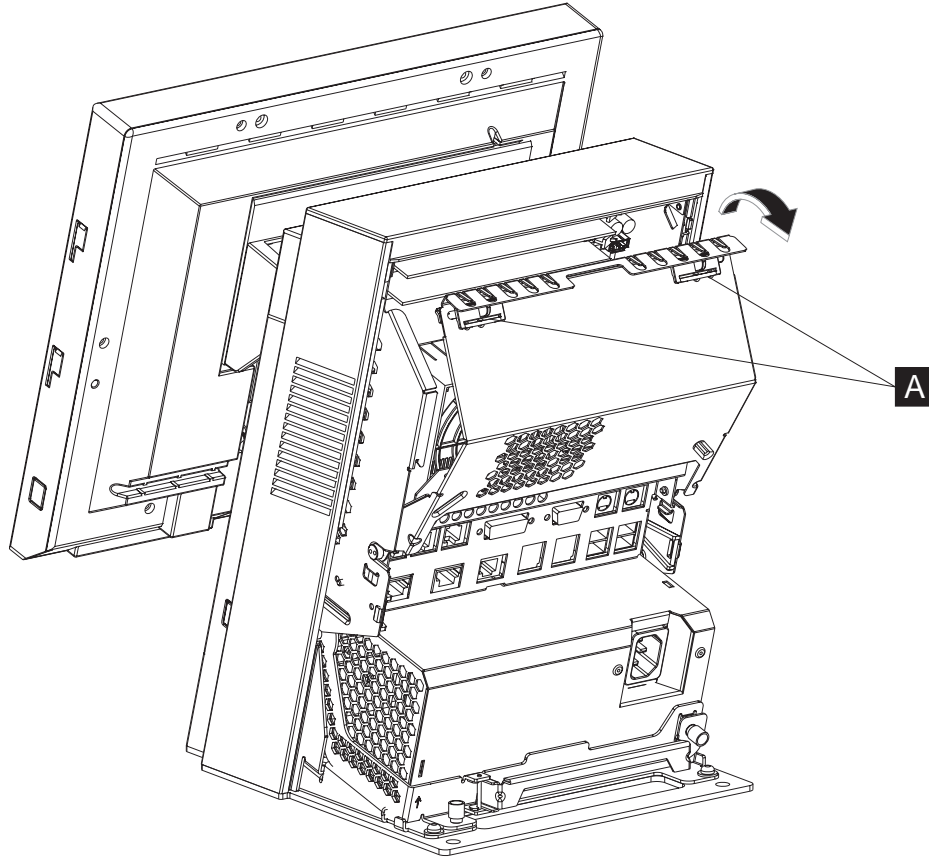

Figure 9. Opening the I/O tailgate cover

- Remove the rear cover as described in “Rear cover removal” on page 31.
- Unlatch the I/O tailgate cover by sliding the latches (**A** in Figure 9) toward the center.
- Open the I/O tailgate cover by rotating it downward.

Top cover removal

1. Switch OFF the power to the SurePOS 500. Unplug the power cord from the external power source.
2. Remove the rear cover, following the procedure in “Rear cover removal” on page 31.
3. Open the I/O tailgate cover (see “Opening the I/O tailgate cover” on page 32).

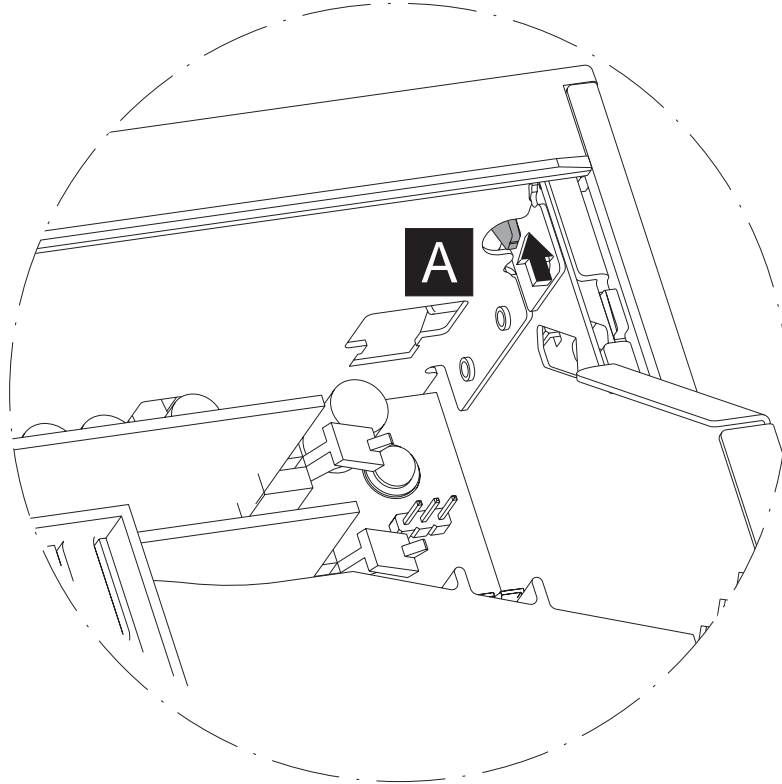

Figure 10. Locating the top cover release latch

4. Facing the rear of the system, use a screwdriver to lift the latch (**A** in Figure 10), while sliding the top cover toward you (toward the rear of the unit)
5. Repeat for the latch on the other side.
6. To replace, slide the top cover on from the rear.

Hinge cover removal

1. Switch OFF the power to the SurePOS 500. Unplug the power cord from the external power source.
2. Remove the display tablet. See “Display tablet - removing and replacing” on page 35.
3. Remove the HDD or front cover. See “Front (or HDD) cover removal” on page 30
4. Remove the top cover as described in “Top cover removal” on page 33.
5. Remove the center cover (**C**) by lifting it off.

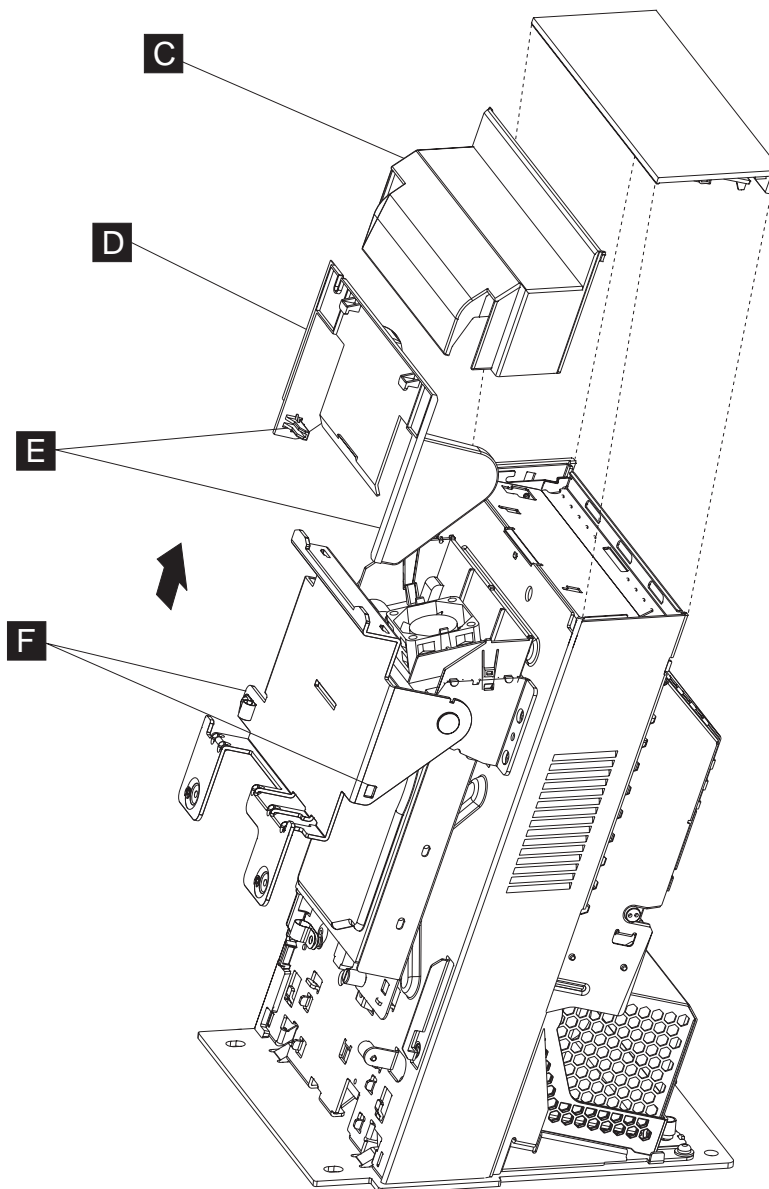

Figure 11. Removing the hinge cover

6. Lift off to remove the hinge cover (**D**).

Note: You will need to pull the sides of the hinge cover away from the hinge so that features (**E**) will clear holes (**F** in Figure 11).

Display tablet - removing and replacing

Follow these procedures to remove the display tablet.

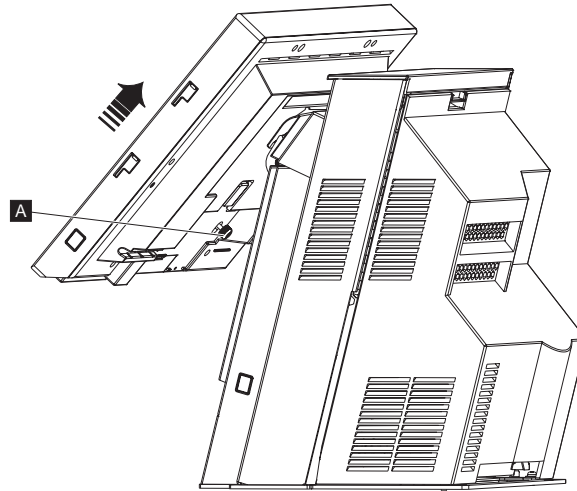

Figure 12. Removing the display tablet

1. Switch OFF the power to the SurePOS 500. Unplug the power cord from the external power source.
2. Tilt the tablet back and loosen the two thumbscrews **A** in Figure 12 under the tablet.
3. If present, unplug the MSR cable.
4. Disconnect the cable from the rear of the tablet by pressing on either side of the connector.
5. Lift the tablet off the unit.
6. To replace, reverse these procedures.

Display tablet cable – removing and replacing

1. Switch OFF the power to the SurePOS 500. Unplug the power cord from the external power source.
2. Remove the tablet as described in “Display tablet - removing and replacing” on page 35.
3. Disconnect the display cable from the rear of the tablet by pressing on either side of the connector.
4. Remove the front cover as described “Front (or HDD) cover removal” on page 30.
5. Remove the speaker, if present. See “Speaker – removing and replacing” on page 64.
6. Remove the rear cover as described in “Rear cover removal” on page 31.
7. Remove the power supply as described in “Power supply – removing and replacing” on page 46.

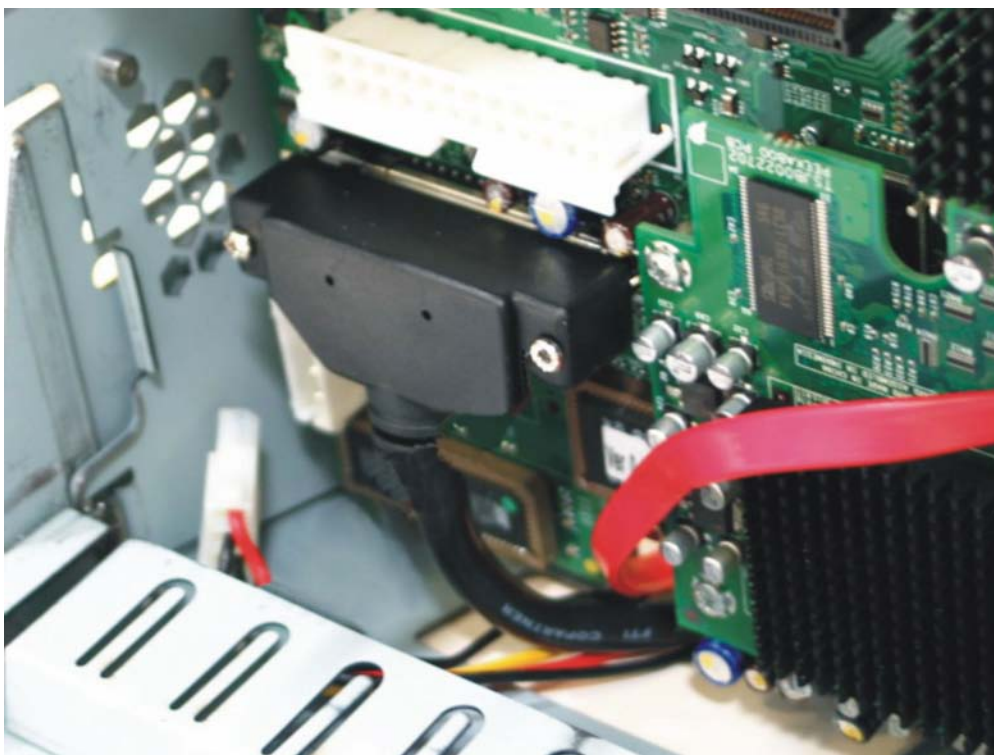

Figure 13. Removing the display tablet cable from the system board

8. Remove the clamps on front of the frame and hinge that retain the tablet cable.
9. Disconnect the display tablet cable from the system board by loosening the two thumbscrews (see Figure 13).
10. Remove the base plate. See “Base plate – removing and replacing” on page 58.
11. Pull the cable free from the plastic guide in the frame.
12. To replace, reverse these procedures.

Front bezel and LCD assembly - removing and replacing

Note: The front bezel and the LCD assembly are available as FRUs.

1. Switch OFF the power to the SurePOS 500. Unplug the power cord from the external power source.
2. If installed, remove the MSR and antenna cover assembly. See “Magnetic stripe reader (MSR) – removing and replacing” on page 59.

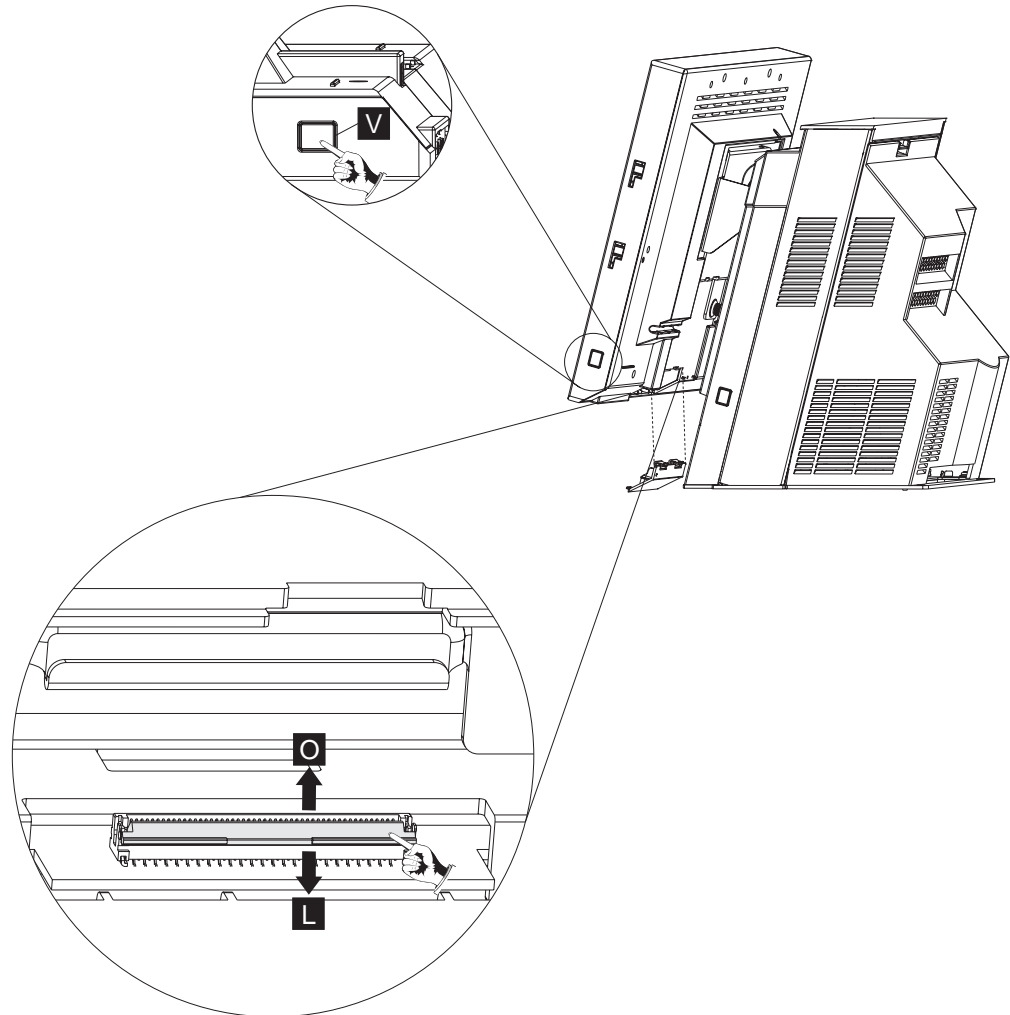

Figure 14. Disconnecting the touch cable and removing the front bezel

3. Remove the touch cable door by lifting on the latch and lifting outward. The cable door will dangle from the connecting tie.
4. Disconnect the touch cable by lifting the connector lever to the open position (**O** in Figure 14) and lifting out the cable.

Note: The OPEN position is away from the touch card and perpendicular to the unit, while the LOCKED position (**L**) is closer to the touch card and parallel with the unit.

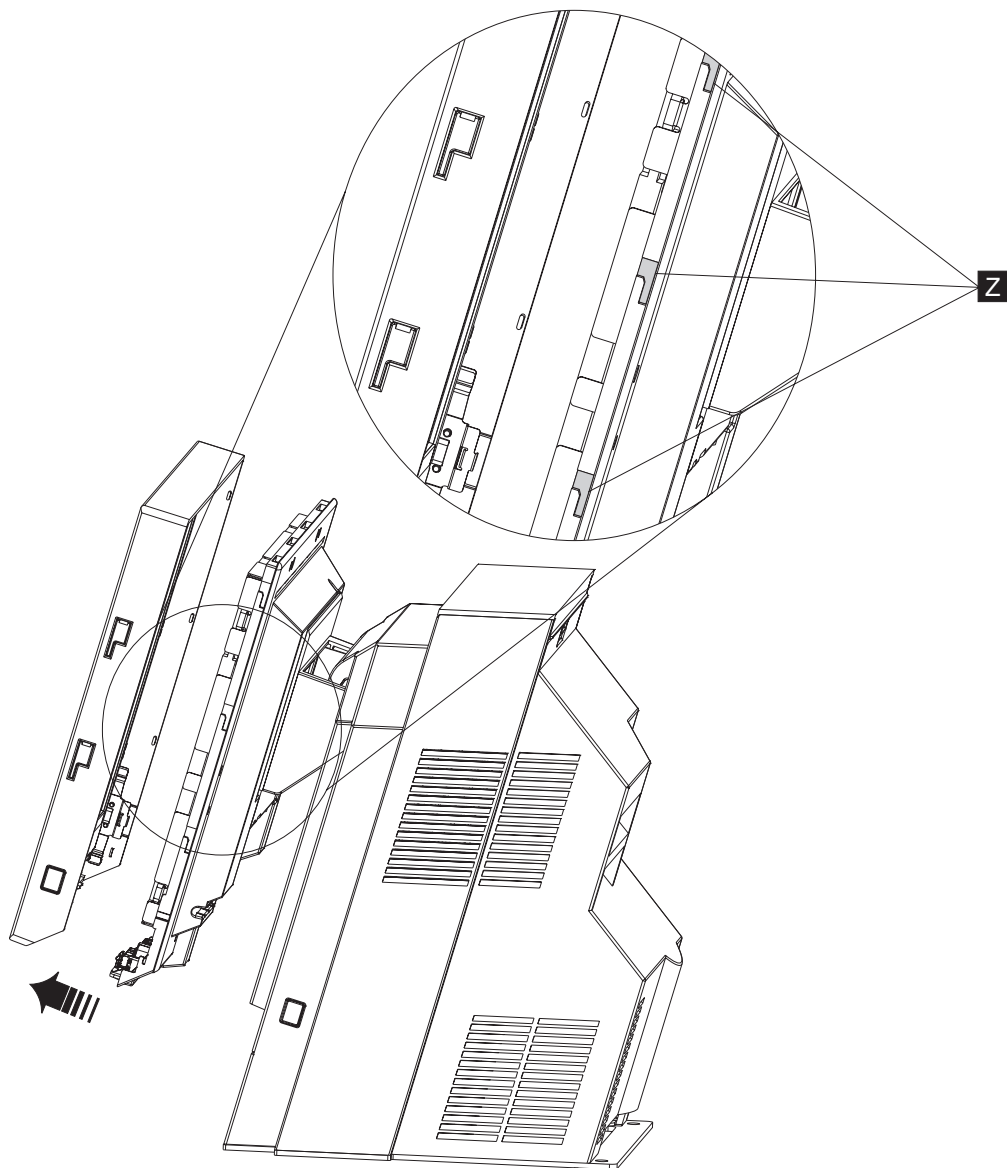

Figure 15. View of L-shaped keyways

5. Press the buttons on either side of the tablet (**V** in Figure 14 on page 37) to unlock the bezel, and lift upward until the bezel stops. Then pull the bezel away from the tablet.
6. Continue to lift the LCD assembly from the front bezel assembly and remove.
7. To replace the front bezel or LCD assembly from the front bezel assembly, reverse these procedures and reconnect the touch cable:
 - a. Ensure that the connector lever is in the open position. See Figure 14 on page 37.
 - b. Insert the cable behind the connector lever.
 - c. Push the connector lever to the locked position (**L** in Figure 14 on page 37).

Note: When replacing the front bezel, be sure to align the tabs in the front bezel into the keyways. See **Z** in Figure 15.

Operator card - removing and replacing

This section describes how to remove the operator card.

1. Switch OFF the power to the SurePOS 500. Unplug the power cord from the external power source.
2. Follow the steps described in “Front bezel and LCD assembly - removing and replacing” on page 37 to lift off the front bezel.

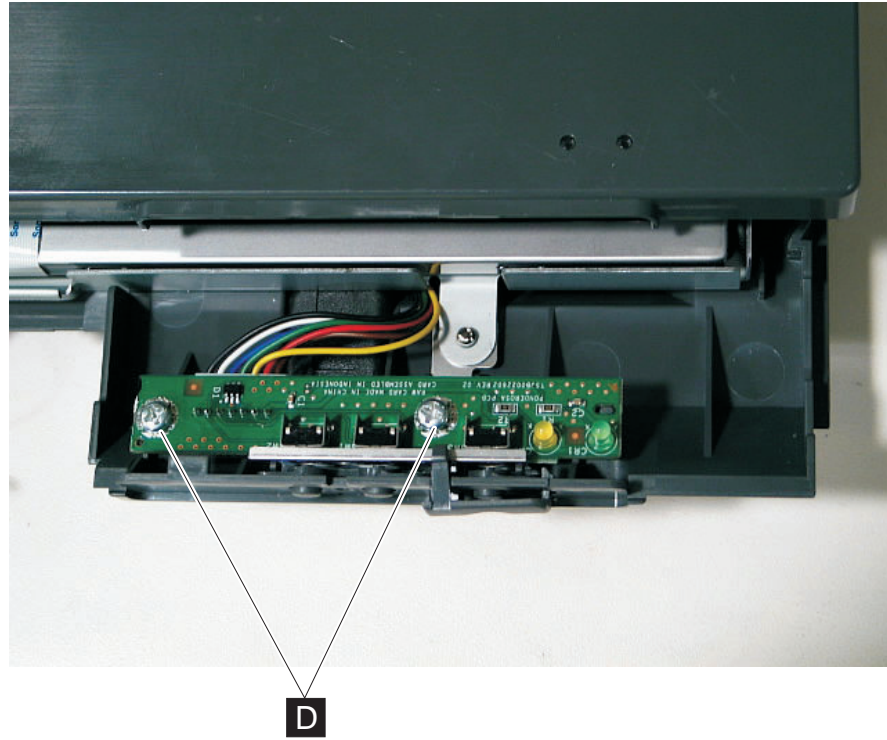

Figure 16. Removing the operator card

3. Disconnect the cable from the operator card.
4. See Figure 16. Remove the two screws (**D**) and lift out the card.
5. To replace, reverse these procedures.

Tablet hinge assembly – removing and replacing

1. Switch OFF the power to the SurePOS 500. Unplug the power cord from the external power source.
2. Remove the tablet as described in “Display tablet - removing and replacing” on page 35
3. Remove the front cover as described in “Front (or HDD) cover removal” on page 30
4. Remove the top cover. See “Top cover removal” on page 33

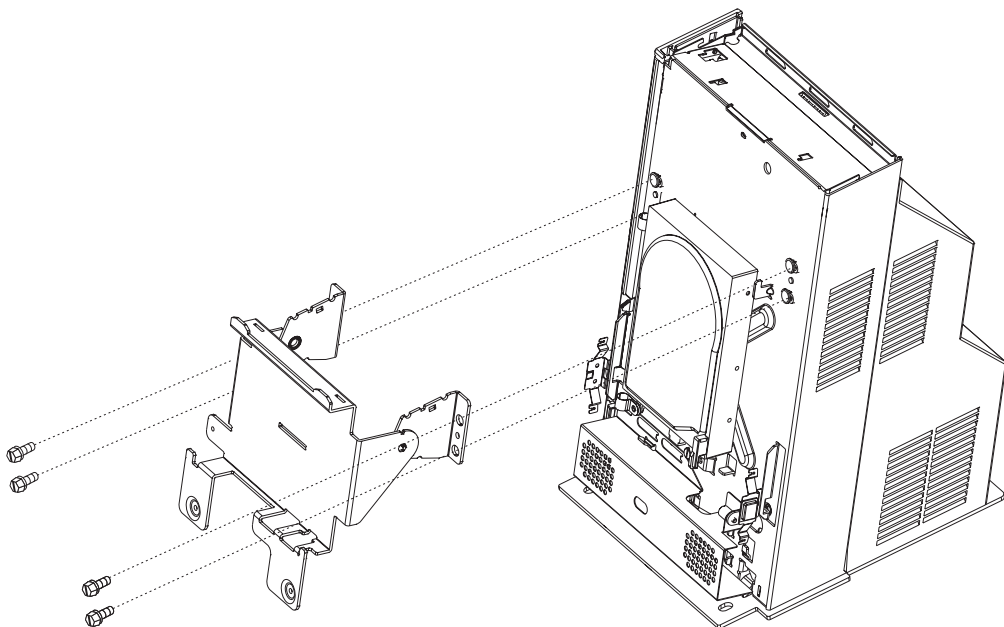

Figure 17. Removing the tablet hinge assembly

5. Lift to remove the tower center cover and the hinge cover (see “Hinge cover removal” on page 34).
6. Remove the four screws shown in Figure 17 and lift off the hinge assembly.
7. To replace, reverse these procedures.

Hard disk drive and bracket – removing and replacing

Attention: The hard disk drive (HDD) is a static-sensitive device. See “Handling static-sensitive devices” on page 28. User care not to drop or jar the HDD during assembly. Do not use an impact power driver.

Note: The HDD and bracket are available together as one FRU, and are also available separately.

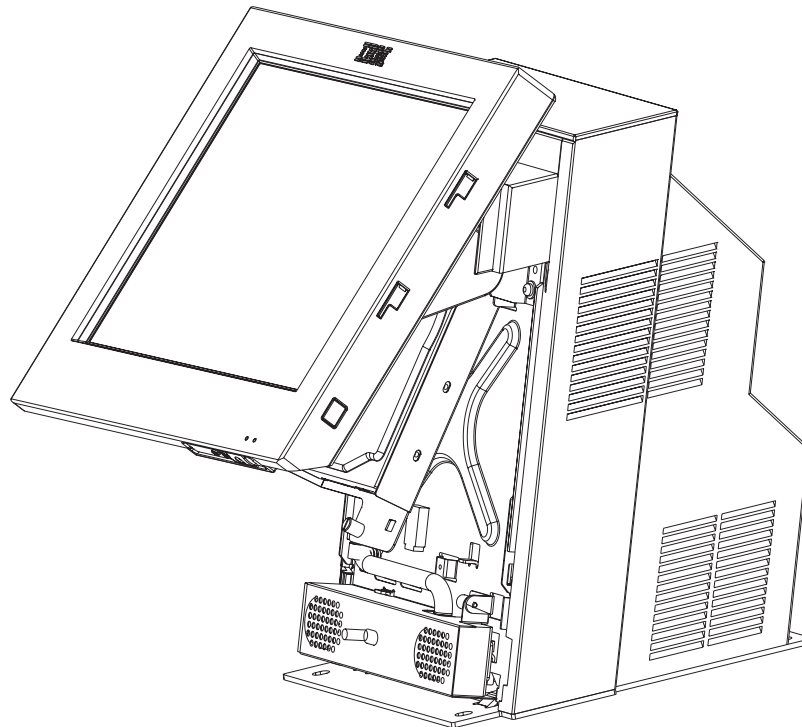

Figure 18. HDD installation. For clarity, this figure shows additional components removed; however, you do not remove these to remove the HDD.

1. Switch OFF the power to the SurePOS 500. Unplug the power cord from the external power source.
2. As shown in Figure 18, tilt back the tablet.
3. Remove the front cover as described at “Front (or HDD) cover removal” on page 30.
4. Disconnect the two cables from the HDD.

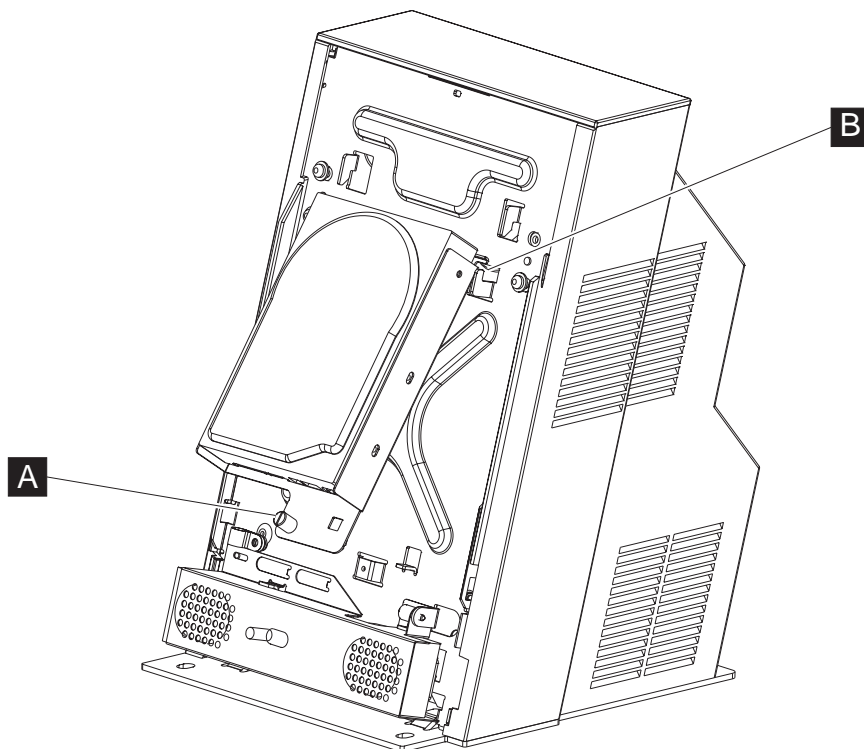

Figure 19. Removing the hard disk drive and bracket. For clarity, this figure shows additional components removed; however, you do not remove these to remove the HDD.

5. See Figure 19. Loosen the captive thumbscrew (**A**) and remove the HDD assembly by lifting it off of the hooks on the frame (**B**).
6. If the HDD is a separate FRU, place the HDD on a flat surface and remove the four screws and bracket.
7. Place the old HDD in protective packaging.
8. Attach the bracket to the new HDD with the four screws.
9. Reinstall the HDD and bracket assembly:
 - a. Reconnect the power and data cables to the HDD.
 - b. Reinsert the HDD and bracket into the frame hooks and replace the thumbscrew
10. Replace the HDD cover.
11. Power on the system and use the CMOS Setup Utility to verify that the system recognizes the new HDD.

Note: If the system fails to recognize the new HDD, verify that all connectors are properly seated and that the address jumper is correctly installed. If the HDD requires a jumper to be recognized as Drive 0, the correct position is indicated on a label on the HDD.

Hard disk drive fan and bracket – removing and replacing

1. Switch OFF the power to the SurePOS 500. Unplug the power cord from the external power source.
2. Remove the rear cover as described in “Rear cover removal” on page 31
3. Remove the top cover (**A** in Figure 20) as described in “Top cover removal” on page 33.

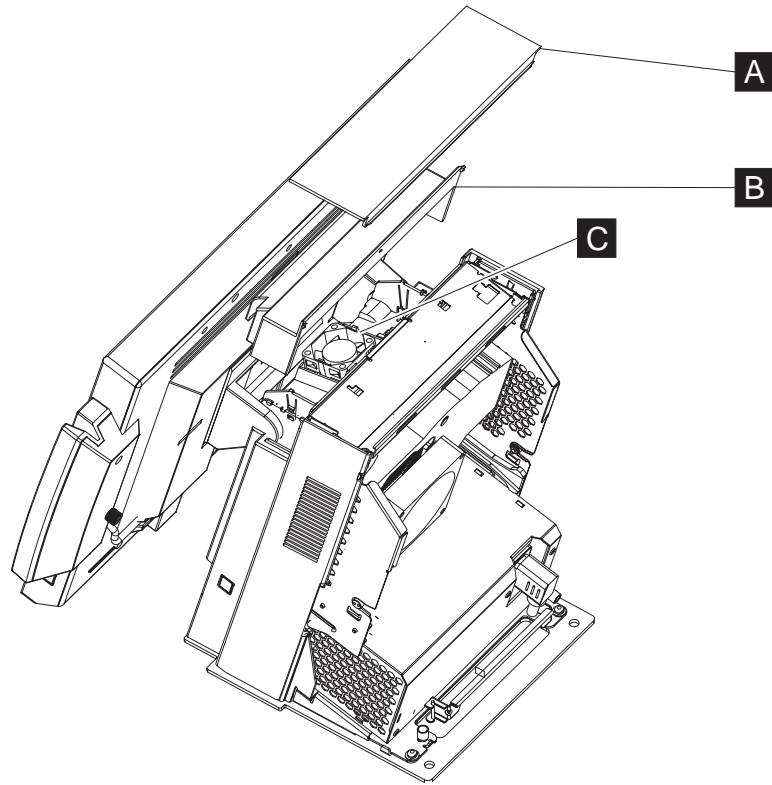

Figure 20. Removing the HDD fan and bracket

4. Remove the tower center cover (**B** in Figure 20) by lifting upward.
5. See Figure 20. Unsnap and remove the HDD fan (**C**) and bracket to remove.
6. Disconnect the cable from the fan.
7. To replace, reverse these procedures.

Hard disk drive cables – removing and replacing

1. Switch OFF the power to the SurePOS 500. Unplug the power cord from the external power source.
2. Tilt back the tablet.
3. Remove the front cover as described at “Front (or HDD) cover removal” on page 30.
4. If present, remove the speaker. See “Speaker – removing and replacing” on page 64.
5. Remove the HDD power connector and data cable connector from the HDD.
6. Cut any cable ties on the cables.
7. Disconnect the power cable and the data cable from the system board.
8. Remove the base plate. See “Base plate – removing and replacing” on page 58.
9. Pull the power cable free from the plastic guide in the frame.
10. To replace, reverse these procedures.

Cable tie bar – removing and replacing

1. Switch OFF the power to the SurePOS 500. Unplug the power cord from the external power source.
2. Follow the instructions described in “Rear cover removal” on page 31.

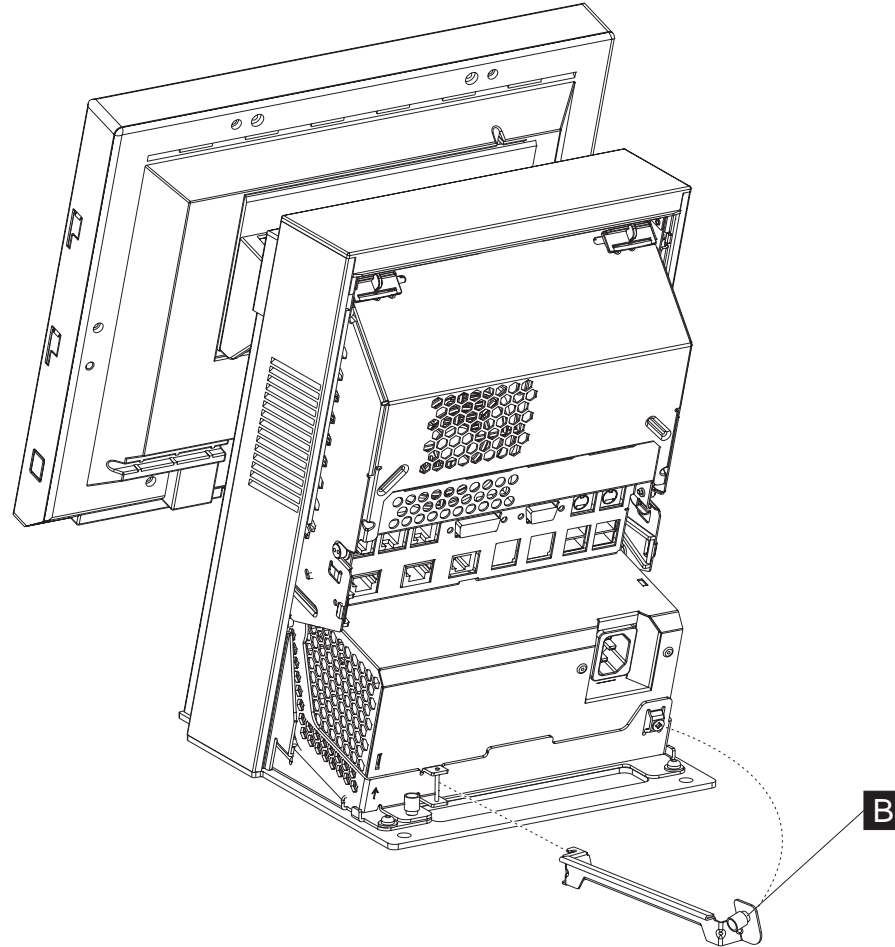

Figure 21. Removing the cable tie bar

3. Loosen the captive thumbscrew **B**, as shown in Figure 21.
4. Remove the latch arm from the hinge by rotating and sliding it from the slots.
5. To replace, reverse these procedures.

Power supply – removing and replacing

1. Switch OFF the power to the SurePOS 500. Unplug the power cord from the external power source.
2. Remove the back cover as described at “Rear cover removal” on page 31.
3. Unplug the AC power cord on the back of the power supply.
4. Unlatch the power supply latch arm by loosening the captive thumbscrew and swinging the arm upward.
5. Lift upward until it stops.
6. Pull the power supply out.

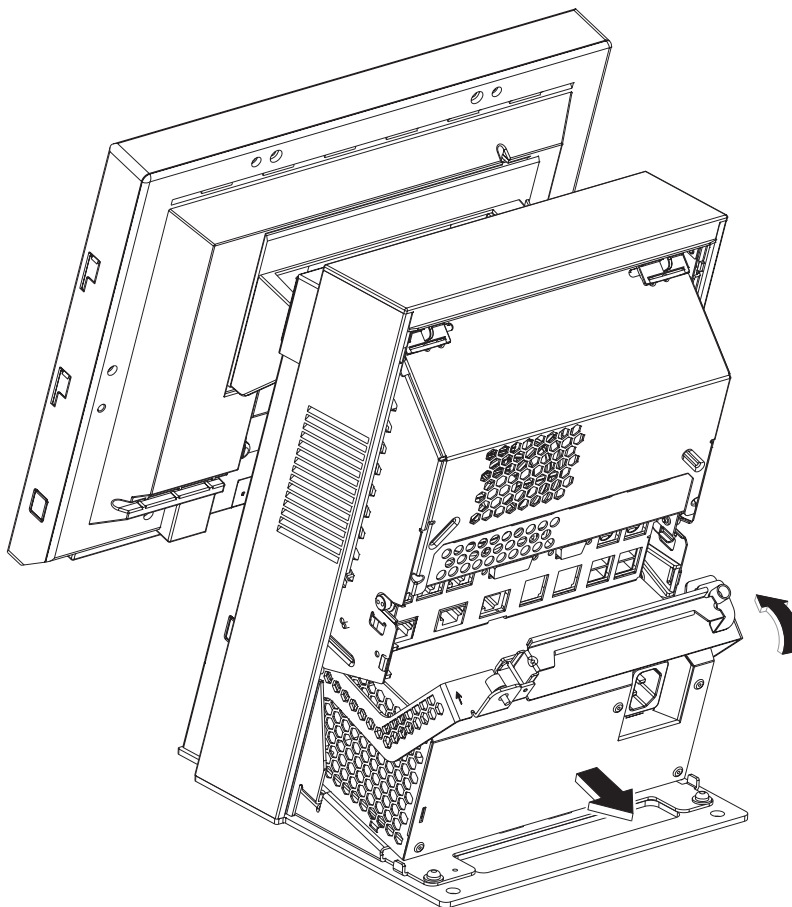

Figure 22. Removing the power supply

7. To replace, make sure the latch arm is all the way up. Slide the power supply into the bottom of the system unit until it stops. Ensure that the power supply latch arm hooks go inside the metal frame.
8. Rotate the latch arm downward and replace the thumbscrew.

Note: You may need to push in at the left bottom of the power supply to get the thumbscrew to align with the screw hole.

Power supply latch arm – removing and replacing

1. Switch OFF the power to the SurePOS 500. Unplug the power cord from the external power source.
2. Follow the instructions described in “Rear cover removal” on page 31.
3. Follow the instructions described in “Power supply – removing and replacing” on page 46

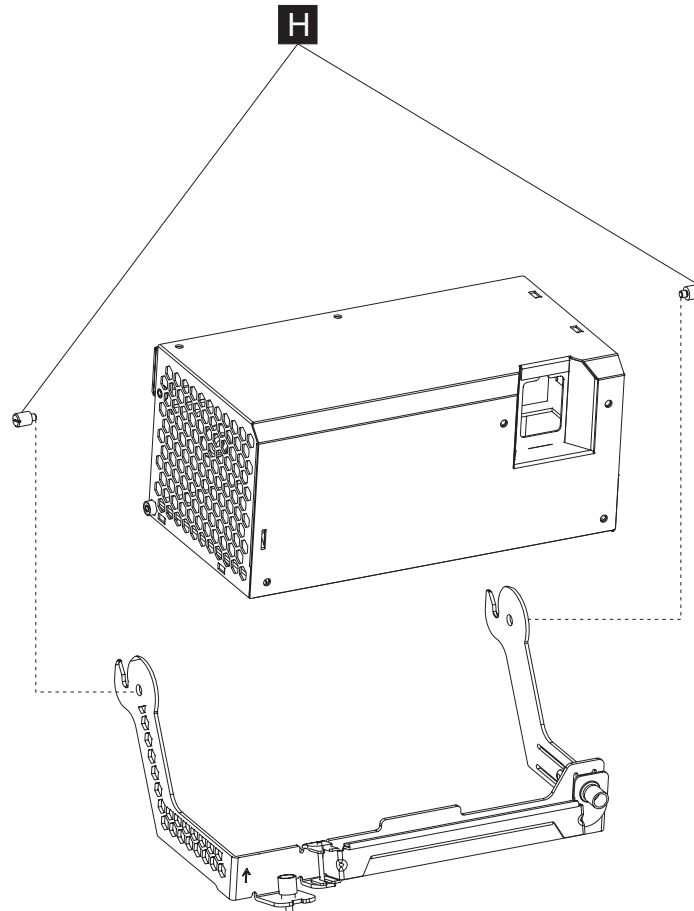

Figure 23. Removing the power supply latch arm

4. Remove screws (**H**) and then lift off the power supply.
5. To replace, reverse these procedures.

Rear connector panel (tailgate) – removing and replacing

1. Switch OFF the power to the SurePOS 500. Unplug the power cord from the external power source.
2. Remove the rear cover as described at “Rear cover removal” on page 31.
3. Disconnect all I/O cables from the tailgate:
 - Speaker
 - Video
 - Serial ATA
 - Power
4. Remove the power supply. See “Power supply – removing and replacing” on page 46.

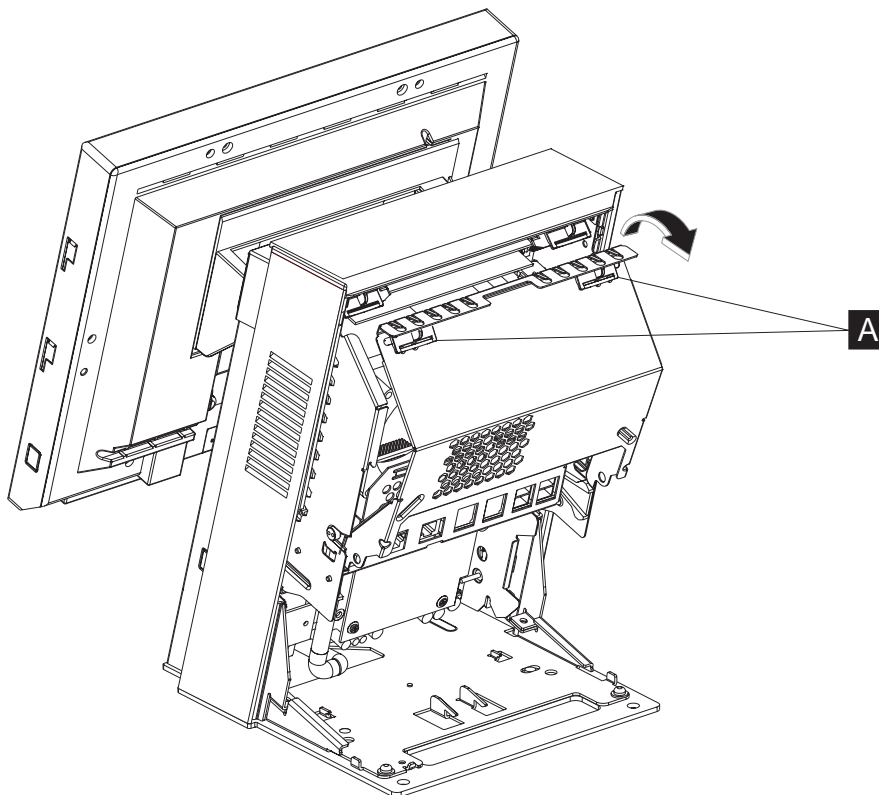

Figure 24. Opening the I/O tailgate cover

5. Unlatch the I/O tailgate cover by sliding the latches (**A** in Figure 24) toward the center.
6. Open the I/O tailgate cover by rotating it downward.

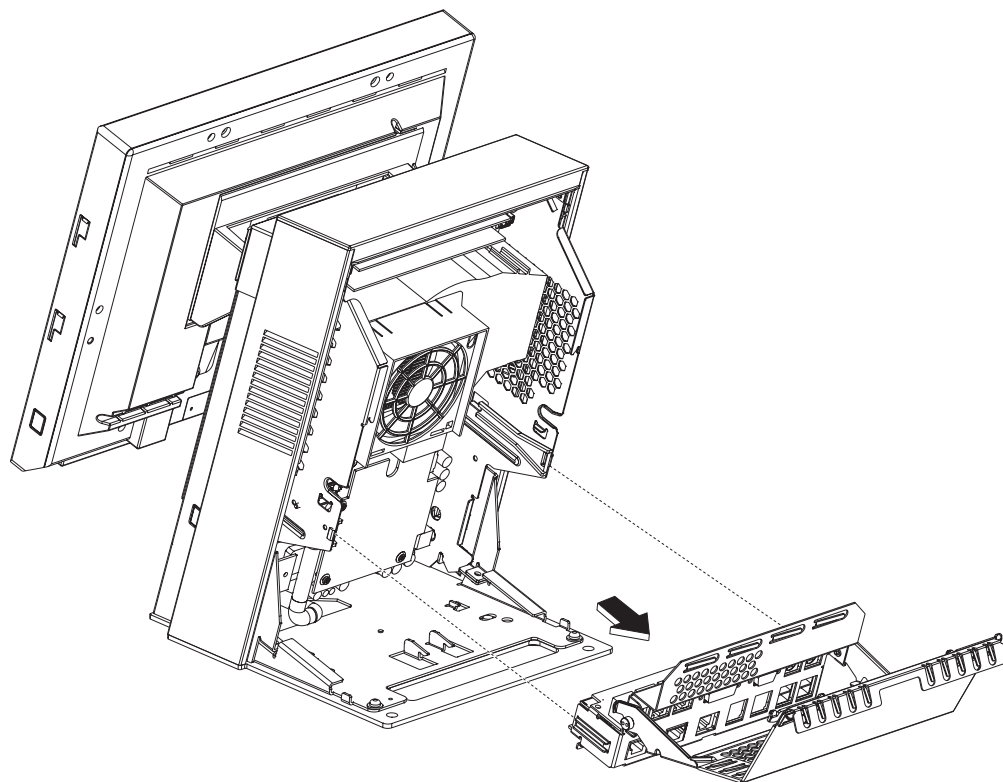

Figure 25. Removing the tailgate

7. As shown in Figure 25, pull the I/O tailgate and attached I/O tailgate cover from the system board.
8. To replace, reverse these procedures, being sure to align the metal tabs on the side of the tailgate with the plastic guides on the frame.

System board – removing and replacing

Attention: Establish personal grounding before touching this unit. See “Electrostatic Discharge (ESD)” on page 136.

Note: The system board assembly comes with a tray and top cover.

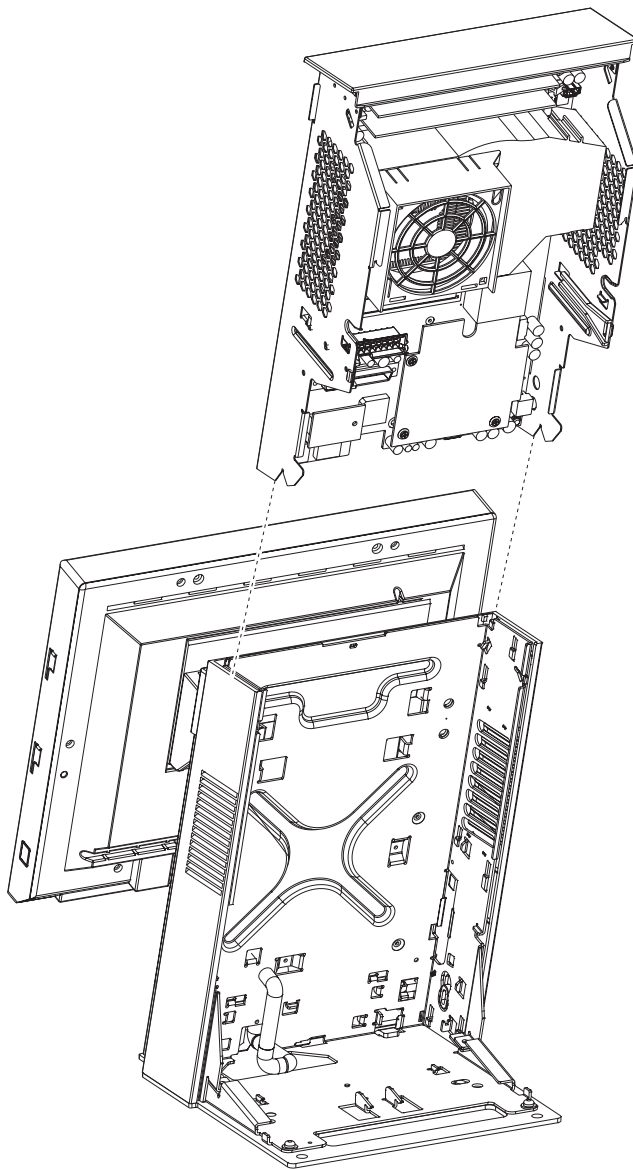

Figure 26. Removing the system board

1. Switch OFF the power to the SurePOS 500. Unplug the power cord from the external power source.
2. Follow the steps described in “Rear cover removal” on page 31.
3. Remove the power supply as described in “Power supply – removing and replacing” on page 46
4. Disconnect the cables and remove the I/O tailgate cover as described in “Rear connector panel (tailgate) – removing and replacing” on page 48
5. Grasp the entire assembly and slide it out toward the top as shown in Figure 26.

Transfer modules to the new system board

Place the assembly on a table and remove the following parts:

- Memory modules – See “Memory modules – removing and replacing” on page 56.
- Heatsink and fan - See “Processor fan/heatsink assembly - removing and replacing” on page 54.
- Processor – See “Processor module – removing and replacing” on page 55.
- Video adapter, if installed. See “Video adapter card– removing and replacing” on page 63.
- Optional integrated VFD

Install these parts on the new system board. The new system board comes with all required jumpers and with a new battery.

Update system software

1. Ensure system BIOS is equal to or greater than that from the old system board. See “Updating the flash BIOS” on page 17.
2. Reprogram the Vital Product Data (VPD).
 - a. Boot using the memory key.
 - b. Choose **POS System Test**.
 - c. Choose **Utilities**.
 - d. Choose **Vital Product Data Utility**.
 - e. Choose **Update VPD**.
 - f. Choose the model and press **Enter**.
 - g. Choose **Update VPD** again.
 - h. Enter the machine serial number and press **Enter**.
 - i. Exit.

System-board jumper location and settings

Figure 27 shows the system-board jumper locations. See the following topics for jumper descriptions and information about jumper settings.

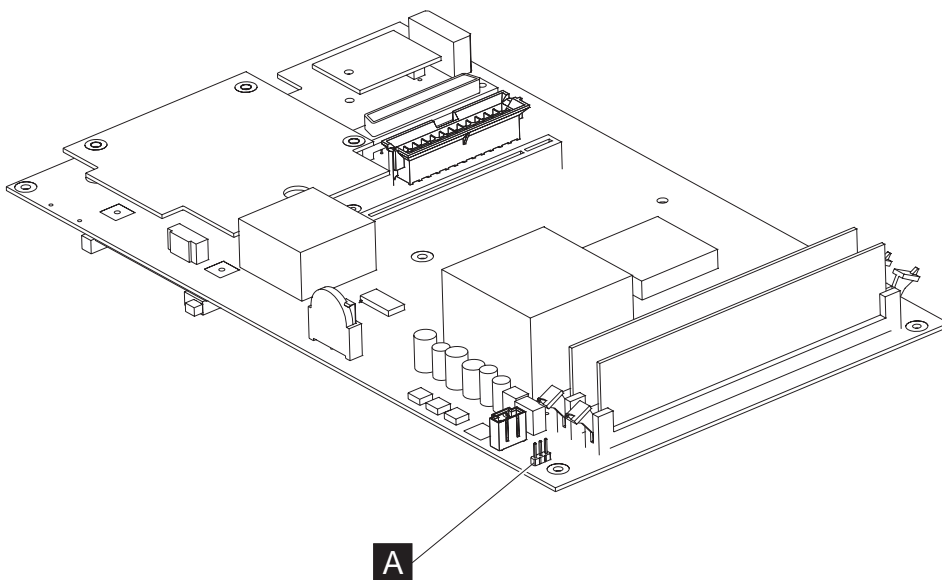

Figure 27. System board jumper location

Table 14 describes the system board jumper setting. All jumper pins have the pin number printed on the system board for easy identification.

Table 14. System board jumper settings

Jumper	Default pin location:	Description
J25	pins 1 and 2	CMOS Memory clear: To clear the CMOS, momentarily place the jumper on pins 2 and 3

System-board battery – removing and replacing

1. Switch OFF the power to the SurePOS 500. Unplug the power cord from the external power source.
2. Remove the rear cover as described at “Rear cover removal” on page 31.
3. Remove the power supply. See “Power supply – removing and replacing” on page 46
4. Remove the I/O tailgate as described in “Rear connector panel (tailgate) – removing and replacing” on page 48

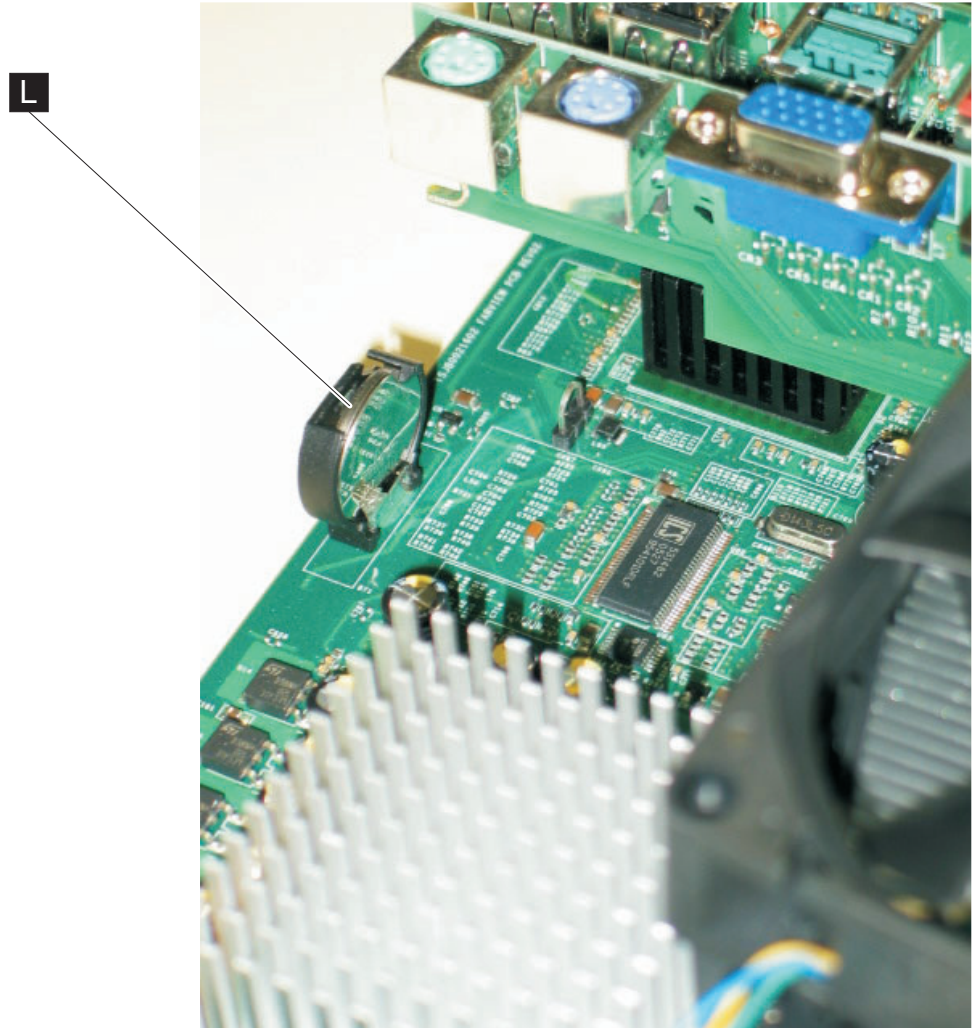

Figure 28. System-board battery

5. Remove the old battery from the slot **L** as shown in Figure 28.
6. Facing the rear of the machine, insert the new battery with the positive side to the left

Processor fan/heatsink assembly - removing and replacing

1. Switch OFF the power to the SurePOS 500. Unplug the power cord from the external power source.
2. Remove the rear cover as described at “Rear cover removal” on page 31.
3. Remove the power supply. See “Power supply – removing and replacing” on page 46
4. Remove the I/O tailgate cover as described in “Rear connector panel (tailgate) – removing and replacing” on page 48
5. Unplug the processor fan cable.

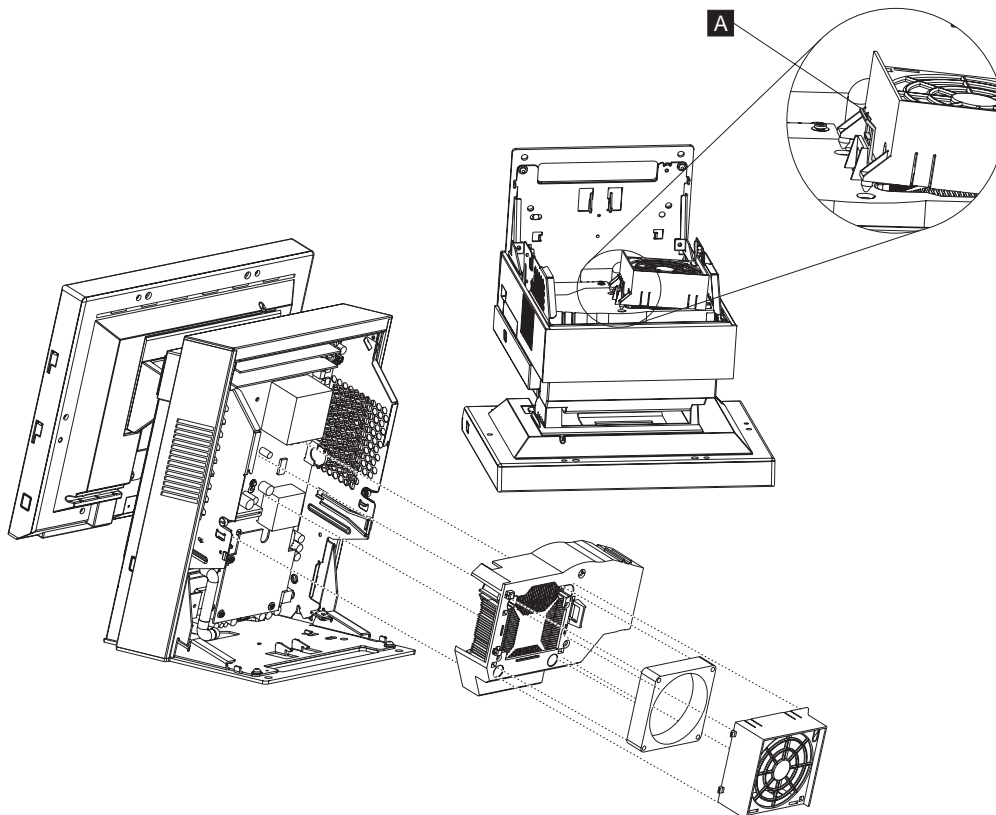

Figure 29. Removing the processor fan/ heatsink assembly. The placement of the unit in the top view is for illustrative purposes only.

6. Press the latch (**A** in Figure 29) on the processor fan bracket and rotate fan bracket away from the duct.
7. Remove the processor fan/heatsink by loosening the four screws.
8. See “Processor module – removing and replacing” on page 55 to remove the processor.
9. Reverse these procedures to replace.

Note: If you are reusing the existing heatsink, make sure that the thermal material is not torn or damaged. Replace, if needed. The thermal material comes installed on a new heatsink or with a new processor.

Processor module – removing and replacing

Note: The processor and fan sink come as one FRU. Do not use the old fan sink when replacing the processor.

Attention: Establish personal grounding before touching this unit. See “Electrostatic Discharge (ESD)” on page 136.

The LGA 775 CPU socket contains very finely pitched pins. You must take care when servicing the CPU as any damage to the socket results in a non-functional system board. Be sure to use the section cup tool provided with the FRU

1. Switch OFF the power to the SurePOS 500. Unplug the power cord from the external power source.
2. Remove the rear cover as described at “Rear cover removal” on page 31.
3. Remove the power supply as described in “Power supply – removing and replacing” on page 46.
4. Remove the tailgate as described in “Rear connector panel (tailgate) – removing and replacing” on page 48.

Attention: The SurePOS Models 545 and 565 contain a LGA 775 CPU socket. This socket contains very finely pitched pins. You must take care when servicing the CPU as any damage to the socket results in a non-functional system board. Be sure to use the section cup tool provided with the FRU processor.

5. Remove the processor fan/heatsink assembly as described in “Processor fan/heatsink assembly - removing and replacing” on page 54.

Note: Examine the thermal interface on the new heatsink. If the thermal interface is damaged, replace the heatsink.

6. Release the latch and carefully remove the processor from the system board.
7. To replace, reverse these procedures.

Memory modules – removing and replacing

Attention: Establish personal grounding before touching this unit. For more information, see “Electrostatic Discharge (ESD)” on page 136.

All system boards have 2 memory sockets. See Figure 30. The factory-installed base memory occupies one of the sockets. If your order is greater than the base memory, you may or may not have an empty socket.

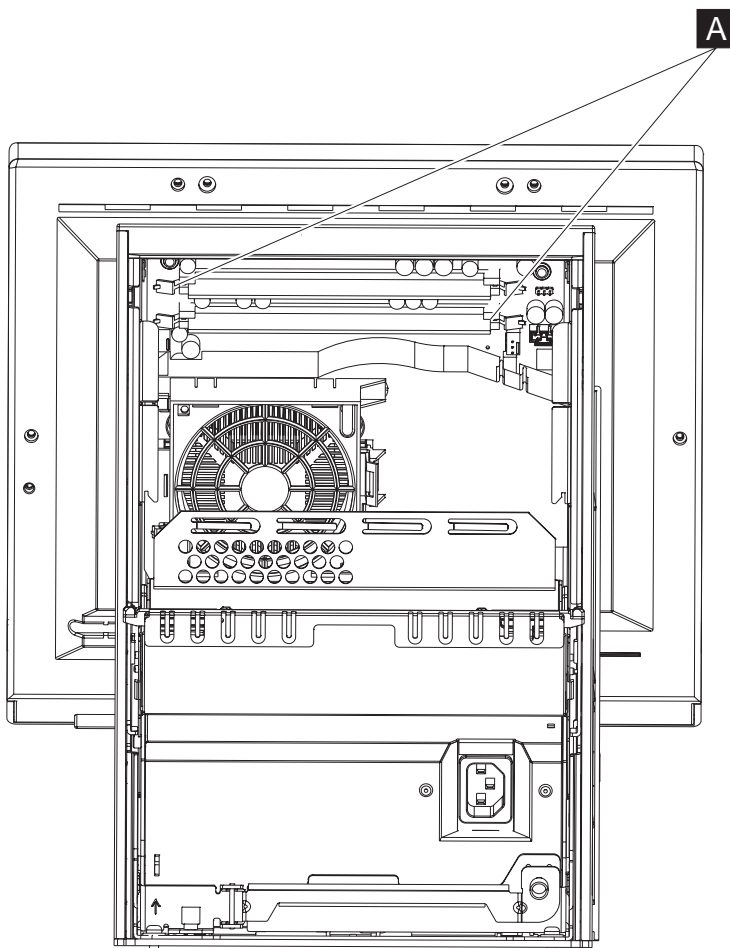

Figure 30. Memory socket location

1. Switch OFF the power to the SurePOS 500. Unplug the power cord from the external power source.
2. Remove the back cover. See “Rear cover removal” on page 31.
3. As shown in Figure 24 on page 48, lower the I/O tailgate cover.
4. Locate the memory modules. See **A** in Figure 30.

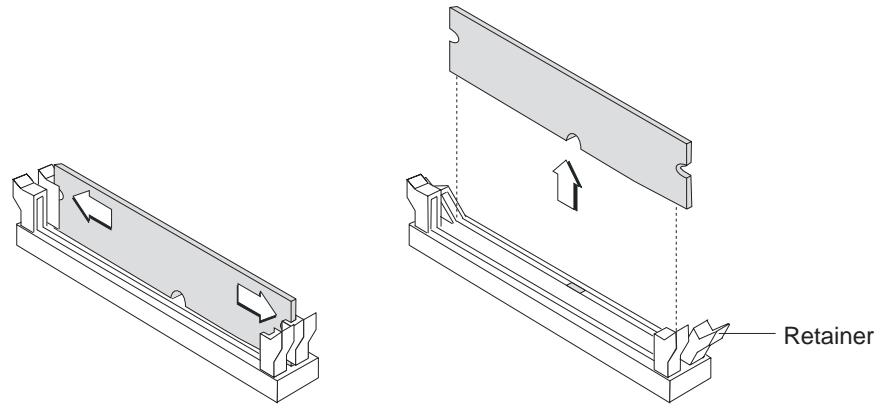

Figure 31. Memory module removal

5. Press the latches away from the module as shown in Figure 31.
6. Touching only the top corners of the module, pull it gently until it is free from the socket.
7. Before inserting a replacement module, note the alignment notch along the bottom of the module and where the module plugs into the slot.
8. Carefully align the module in the slot and then press it into the slot until it is secured by the clip.

Note: Ensure the memory module is fully seated in the socket and the retainer tabs are fully upright and engaged in the memory module side notches.

9. Replace the I/O tailgate cover.
10. Replace the rear cover.

Memory modules and industry standards

You should only use memory provided by IBM Retail for use in Models 545 and 565. Although advertised as *industry standard*, all memory does not work with every product, IBM performs extensive life and reliability testing to insure that memory offered by IBM will operate correctly over all voltage and temperature ranges.

Base plate – removing and replacing

1. Switch OFF the power to the SurePOS 500. Unplug the power cord from the external power source.
2. Remove the rear cover as described in “Rear cover removal” on page 31.
3. Open the cable tie bar and disconnect all of the cables.
4. Remove the two screws **S** attaching the base plate to the frame.
5. Slide the tower toward the rear and lift it off the base.

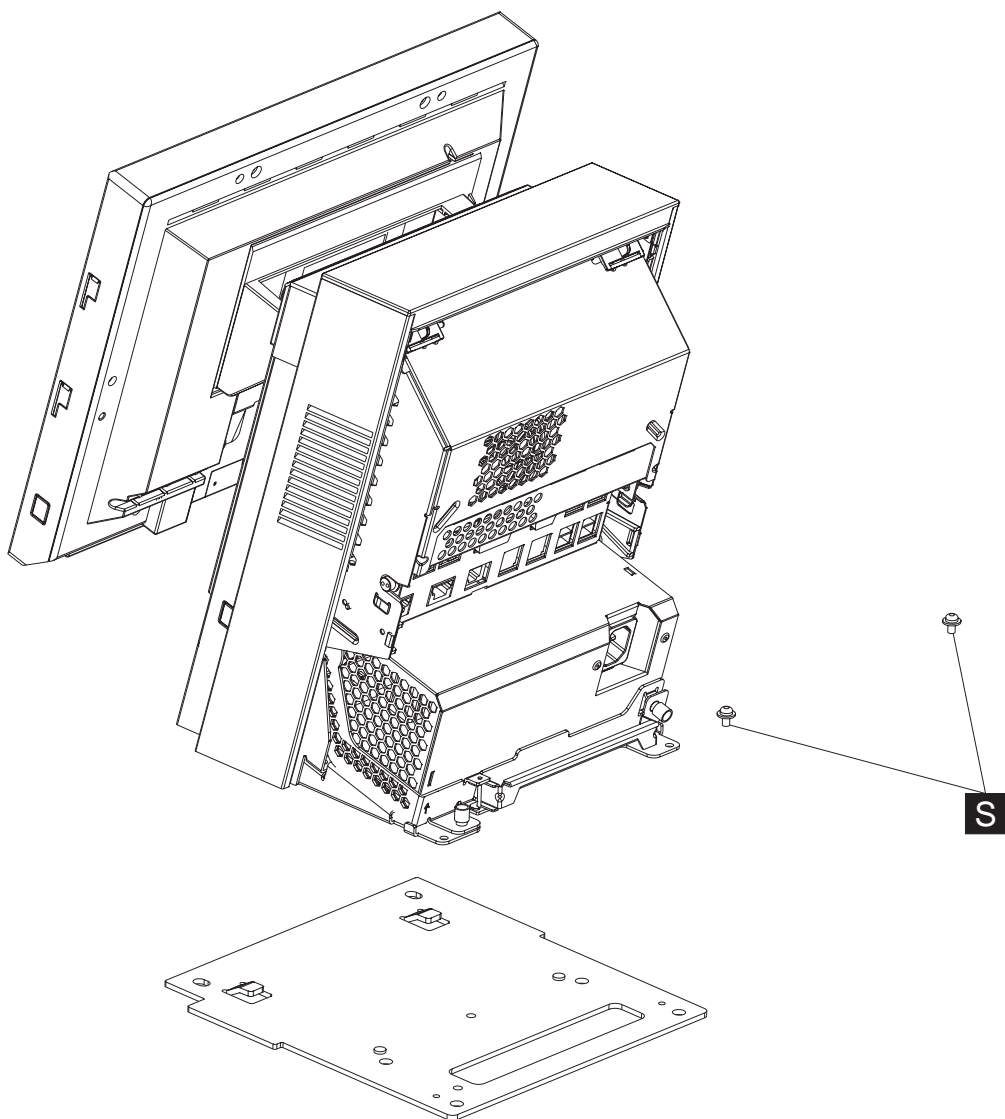

Figure 32. Removing the base plate

Optional features

This section describes how to remove and replace the optional features.

Magnetic stripe reader (MSR) – removing and replacing

1. Switch OFF the power to the SurePOS 500. Unplug the power cord from the external power source.
2. Unplug the MSR cable **A**, as shown in Figure 33 and remove the cable from the cable groove **B**.
3. Remove the thumbscrew **C** that secures the MSR.
4. Slide the MSR **D** up and off.

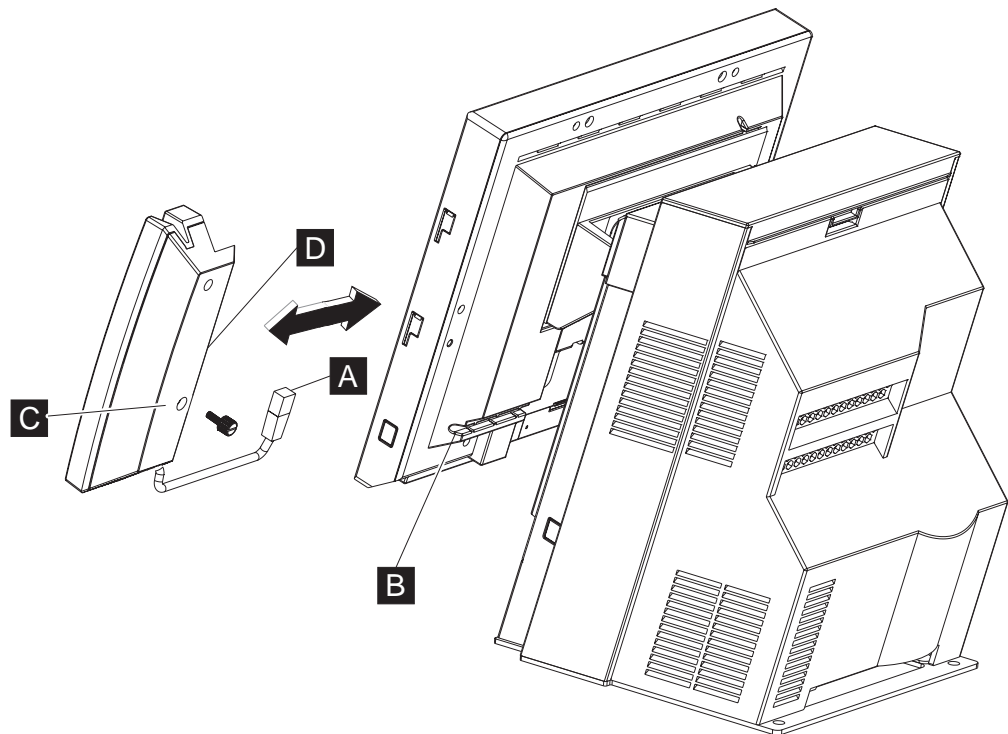

Figure 33. Removing the MSR

To replace the MSR, reverse this procedure.

Note: If you are replacing a dual-sided, single-track MSR, you must set the switch under the MSR cover next to the slot to either the RS-232 or keyboard position, depending on the configuration of the MSR removed.

After installation, run the diagnostics to ensure that the MSR operates correctly. See “Using the IBM Diagnostics for POS Systems and Peripherals package” on page 16.

MSR hole plug – removing and replacing

1. Use a screwdriver to pry off the MSR hole plug.
2. To replace, align plug with hole and press.

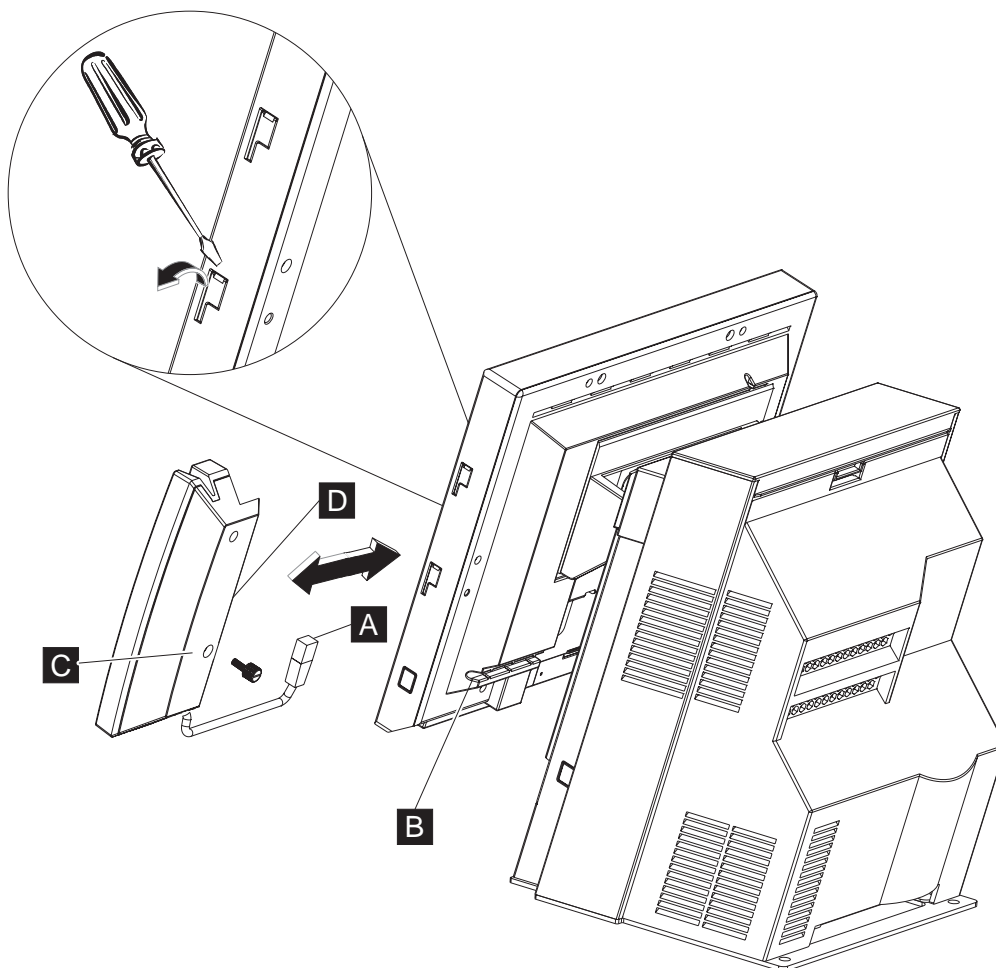

PC card blank – removing

1. Switch OFF the power to the SurePOS 500. Unplug the power cord from the external power source.
2. Remove the HDD cover. See “Front (or HDD) cover removal” on page 30.
3. Remove the door in the direction shown in Figure 34 on page 61.

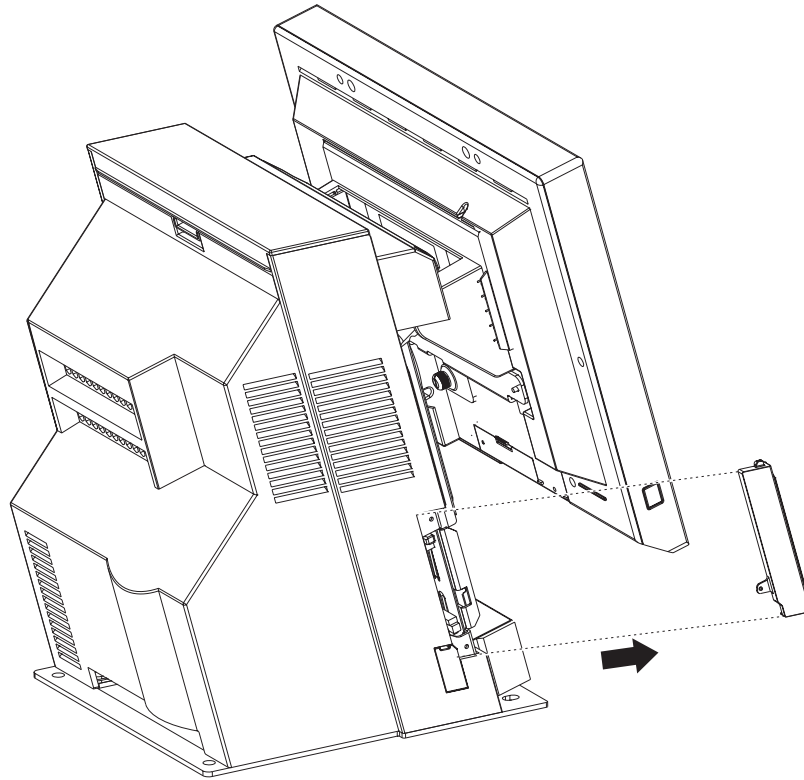

Figure 34. Removing the PC card adapter slot blank

PC card – removing and replacing

1. Switch OFF the power to the SurePOS 500. Unplug the power cord from the external power source.
2. Remove the front cover. See “Front (or HDD) cover removal” on page 30.
3. Remove the PC card cover as shown in Figure 34.
4. If a wireless LAN antenna cover is present, remove the two screws, as shown in Figure 35 on page 62.
5. Press the PC card adapter eject button. Do not pull the interface cable to remove the adapter card and connector. Gently pull on the adapter card.

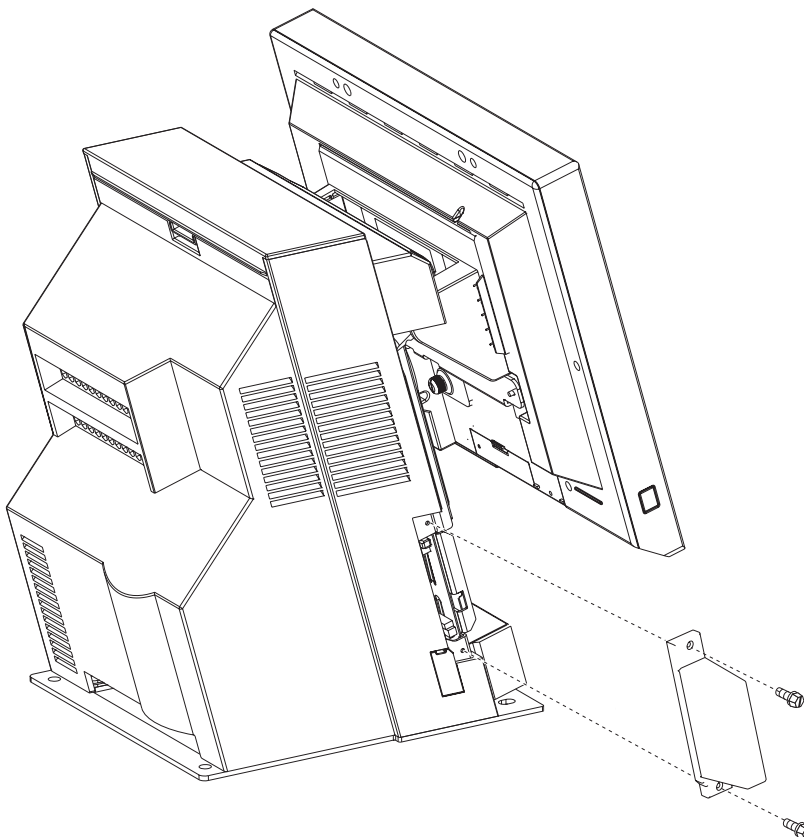

Figure 35. Removing a PC card adapter

6. To replace, reverse these procedures.

For information about defining the PC card to the system, see “Using the CMOS Setup Utility” on page 13.

Note: Before removing a PC card with the system unit running Windows, IBM recommends that you stop the PC card in Windows before you physically remove it.

After installation, run the diagnostics to ensure that the PC card operates correctly. See “Using the IBM Diagnostics for POS Systems and Peripherals package” on page 16.

Video adapter card– removing and replacing

Attention: The dual-video adapter is a static-sensitive device. See “Handling static-sensitive devices” on page 28.

1. Switch OFF the power to the SurePOS 500. Unplug the power cord from the external power source.
2. Remove the back cover as described at “Rear cover removal” on page 31.
3. Remove the power supply. See “Power supply – removing and replacing” on page 46
4. Remove the three screws shown in Figure 36 and remove the video adapter card.

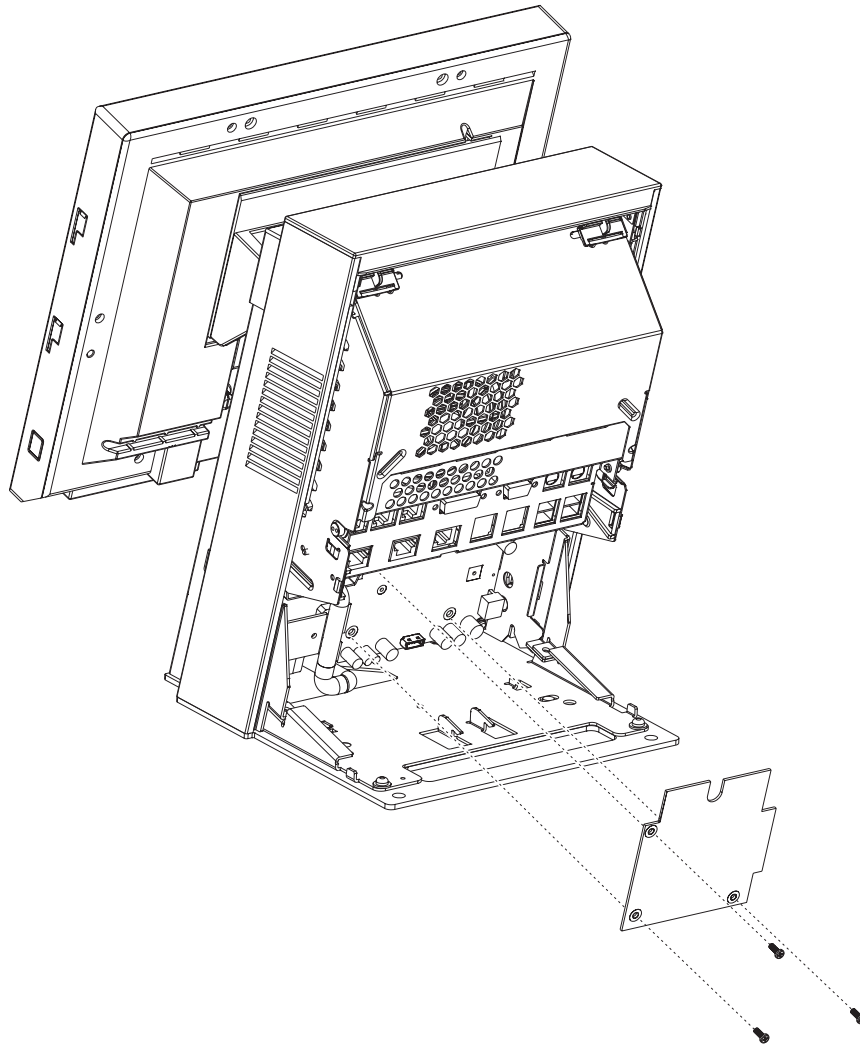

Figure 36. Video adapter card removal

5. To replace, reverse these procedures.

After installation, run the diagnostics to ensure that the video adapter card operates correctly. See “Using the IBM Diagnostics for POS Systems and Peripherals package” on page 16.

Speaker – removing and replacing

1. Switch OFF the power to the SurePOS 500. Unplug the power cord from the external power source.
2. Remove the front cover as described in “Front (or HDD) cover removal” on page 30

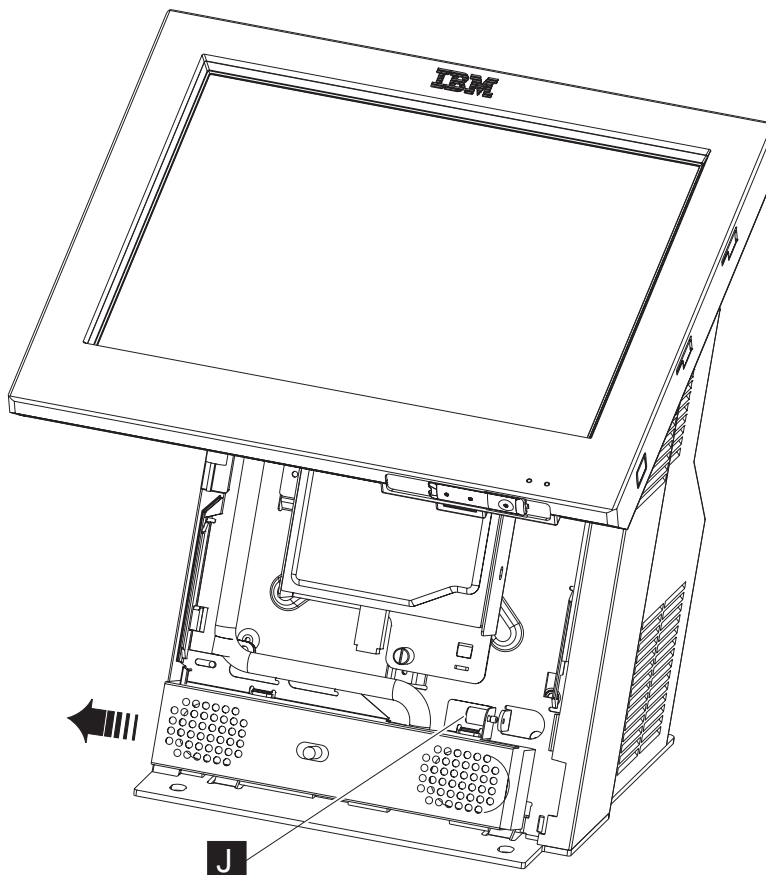

Figure 37. Removing the speaker thumbscrew

3. Loosen the speaker cover thumbscrew as shown in **J** in Figure 37.

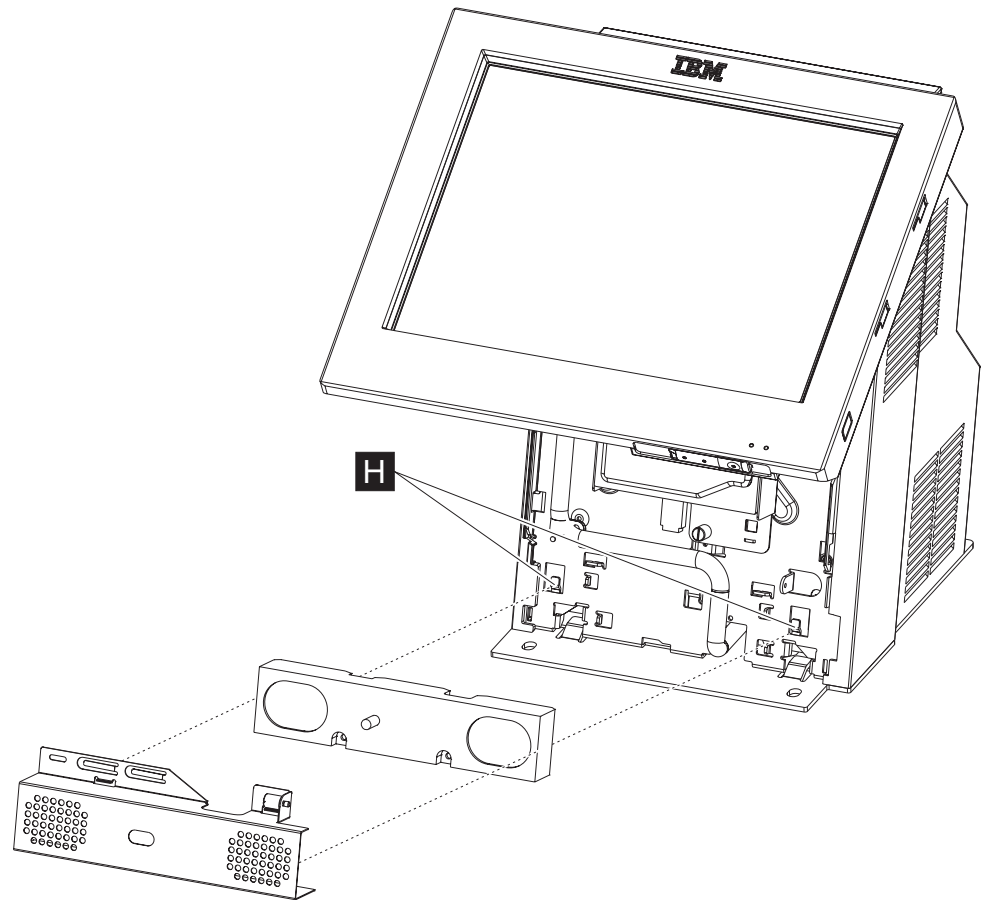

Figure 38. Removing the speaker and speaker EMC shield

4. Slide the speaker shield to the left and lift it off of the hooks (**H** in Figure 38) to remove.
5. Disconnect the speaker cable from the speaker extension cable.
6. To replace, reverse these procedures.

Note: The speaker hooks must fit into the hooks on the frame, or the HDD cover will not close properly.

Integrated customer display – removing and replacing

1. Switch OFF the power to the SurePOS 500. Unplug the power cord from the external power source.
2. Remove the rear cover. See “Rear cover removal” on page 31.
3. Open the I/O tailgate cover by opening the latches and lowering the cover.

Note: You do not need to remove the tailgate cover.

4. Disconnect the integrated display cable from the rear of the system board.

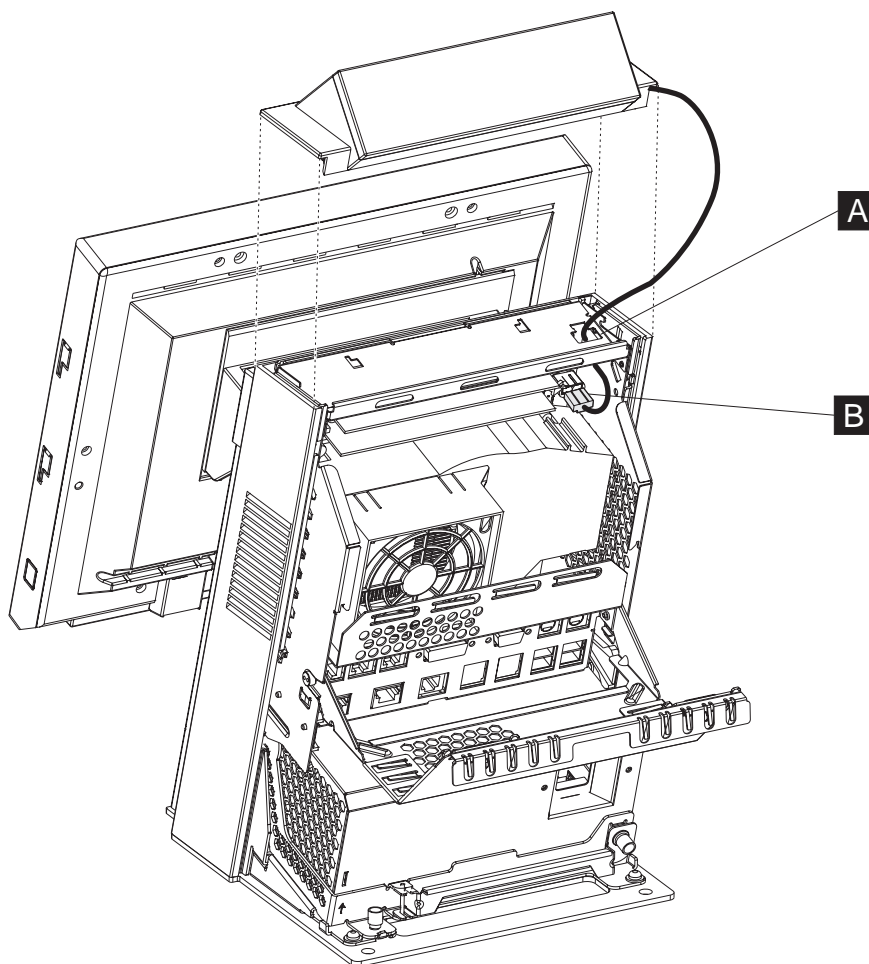

Figure 39. Removing the integrated display

5. Remove the existing integrated display or top cover. See “Top cover removal” on page 33.
6. Snap the new integrated display in place, after routing the cable through the hole (**A** in Figure 39 in the top of the unit.
7. Connect the cable to the rear upper-right corner (**B**) of the system board.
8. Close the I/O tailgate cover and replace the rear cover.
9. To replace, reverse these procedures.

After installation, run the diagnostics to ensure that the integrated display operates correctly. See “Using the IBM Diagnostics for POS Systems and Peripherals package” on page 16.

Modular flash drive – removing and replacing

Attention: The modular flash drive is a static-sensitive device. See “Handling static-sensitive devices” on page 28.

1. Switch OFF the power to the SurePOS 500. Unplug the power cord from the external power source.
2. Remove the rear cover as described in “Rear cover removal” on page 31.
3. Unplug the AC power cord on the back of the power supply.
4. Remove the power supply. See “Power supply – removing and replacing” on page 46.
5. Remove tablet cable connector end from the system board by loosening the two thumbscrews as shown in “Display tablet cable – removing and replacing” on page 36.
6. The modular flash drive **A** is installed on the system board on the lower left side of the panel.

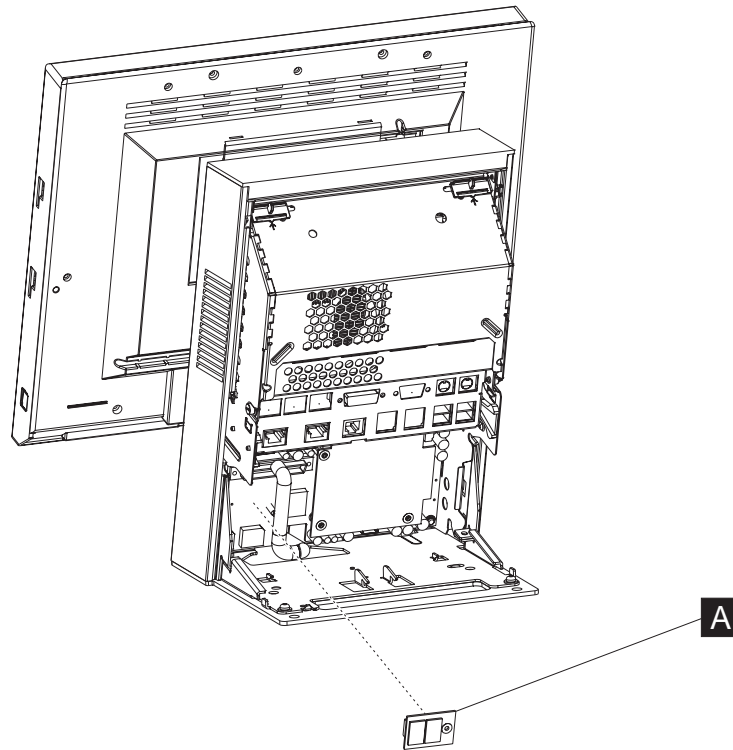

Figure 40. Modular flash drive

7. When removing the flash drive, squeeze the tip of the white plastic stand off to release the flash drive.
8. Grasp firmly and pull directly back to avoid damaging pins.
9. To replace, reverse these procedures.
10. When installing, make sure to line up the flash drive hole with the standoff and push in to fully seat the connector.

Chapter 4. Mounting the SurePOS 500 Models 545 and 565

Mounting the base plate on a countertop	71
Non-keyboard-integration tray mounting	74
Countertop with non-keyboard-integration tray mounting	74
Installing filler panels without a printer	79
Cash drawer	79
Keyboard-integration tray	84
Countertop and full-size cash drawer	84
Mounting the integration tray to a countertop	84
Installing additional peripheral devices	93
Mounting a distributed customer display and APA display to a cash drawer	93
Installing IBM 4610 SureMark Models TF6 or TF7 printers	95

Table 15 describes the various mounting configurations of the SurePOS 500.

Note

Figures in this section are representative of the SurePOS 500 family and may have slight differences with the Models 545 and 565. All mounting procedures are accurate.

Table 15. Mounting configurations

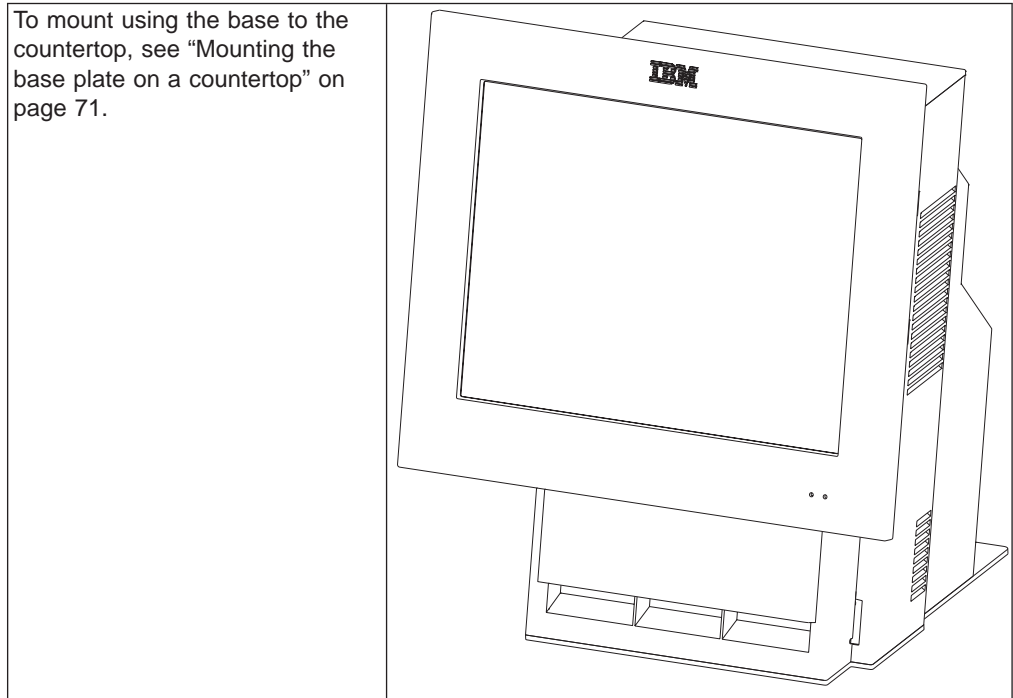

Table 15. Mounting configurations (continued)

<p>To mount to a countertop using the non-keyboard-integration tray, see "Countertop with non-keyboard-integration tray mounting" on page 74.</p>	
<p>To mount on a cash drawer using the non-keyboard-integration tray, see "Cash drawer" on page 79.</p>	

Table 15. Mounting configurations (continued)

To mount on a countertop or cash drawer using the keyboard-integration tray, see “Countertop and full-size cash drawer” on page 84

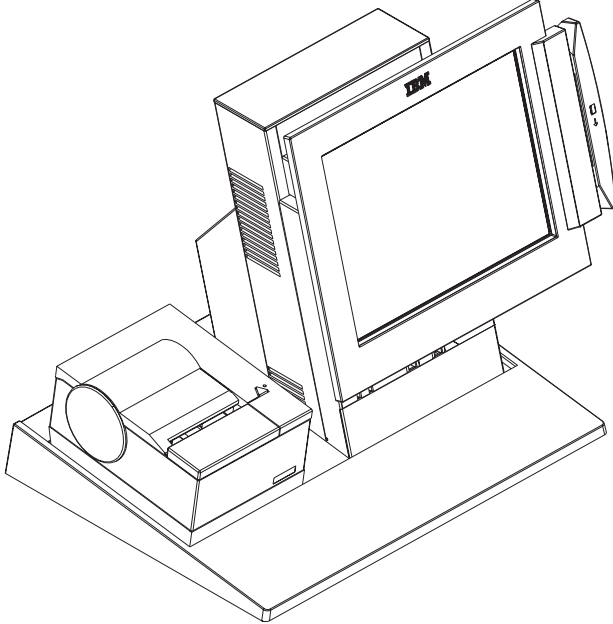
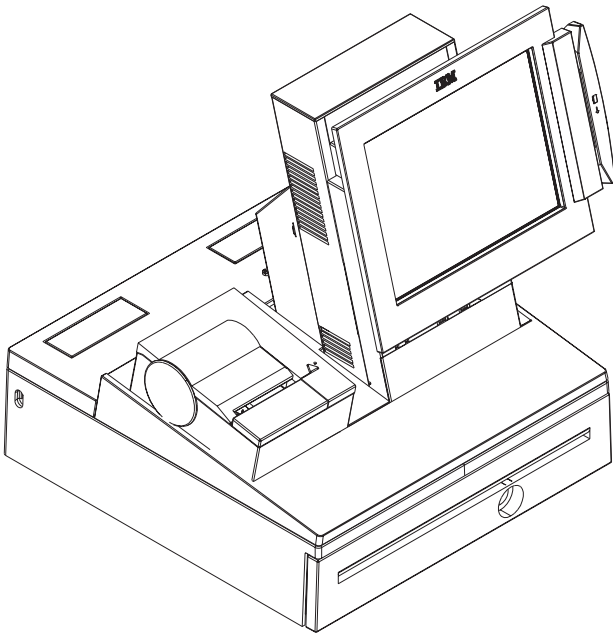
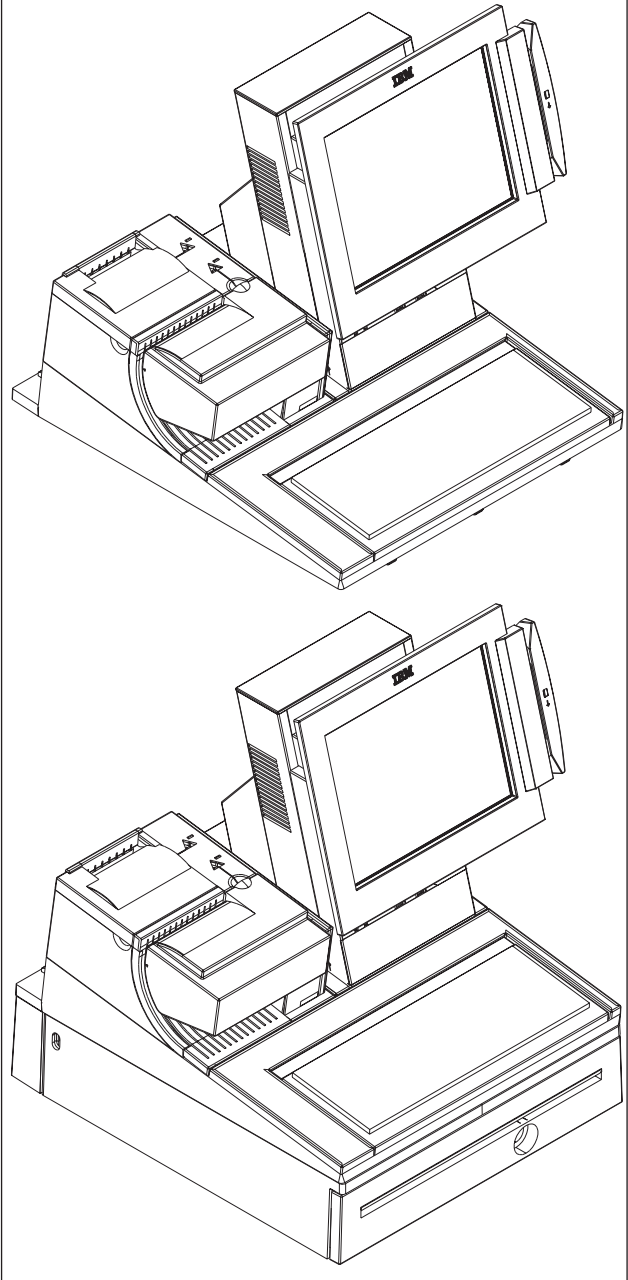

Before mounting your system, first install any internal and external devices on the unit.

Mounting the base plate on a countertop

You can mount the SurePOS 500 Models 545 and 565 free-standing base plate to a countertop with two or four mounting screws. If you are routing the cables under the counter, you can use the base plate as a pattern to cut out your counter or use the specific mounting hole and cutout dimensions as shown in Figure 41 on page 72.

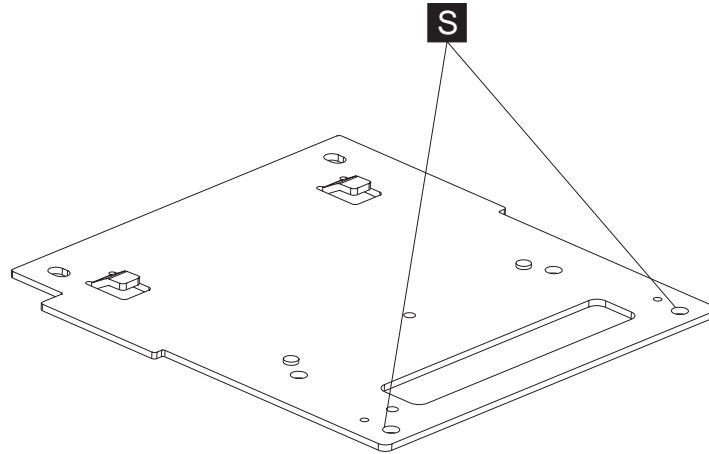

Figure 42. Attaching the base foot to the countertop

5. Connect the power cable to the power supply.
6. Connect the peripheral device cables to the appropriate ports on the rear connector panel. Make the connections on the bottom row of the connector panel first and work upward. Ensure that the cables are routed to the right of the power cord.

Note: For a diagram of the port layout, see “Connectors, power, and brightness controls” on page 5.

7. Rotate the cable-tie bar back into place and tighten the thumbscrew.
8. Use tie-wraps to secure cables to the cable-tie bar, if desired.
9. Replace the rear cover.
10. Plug the AC power cord into an AC outlet.
11. After your installation is complete, switch ON the power to the SurePOS 500 and verify that the system is operating correctly by checking the indicator lights (LEDs) on the front of the touch screen.
12. Install your software. Refer to *IBM SurePOS Model 545 and 565 Operating System Installation Guide*.

Non-keyboard-integration tray mounting

Some integration trays for countertop are designed to accommodate a keyboard and cash drawers, and some are not. The procedures in this section are for non-keyboard-integration tray mounting for the countertop and cash drawer. For keyboard-integration tray mounting, go to “Countertop and full-size cash drawer” on page 84.

Countertop with non-keyboard-integration tray mounting

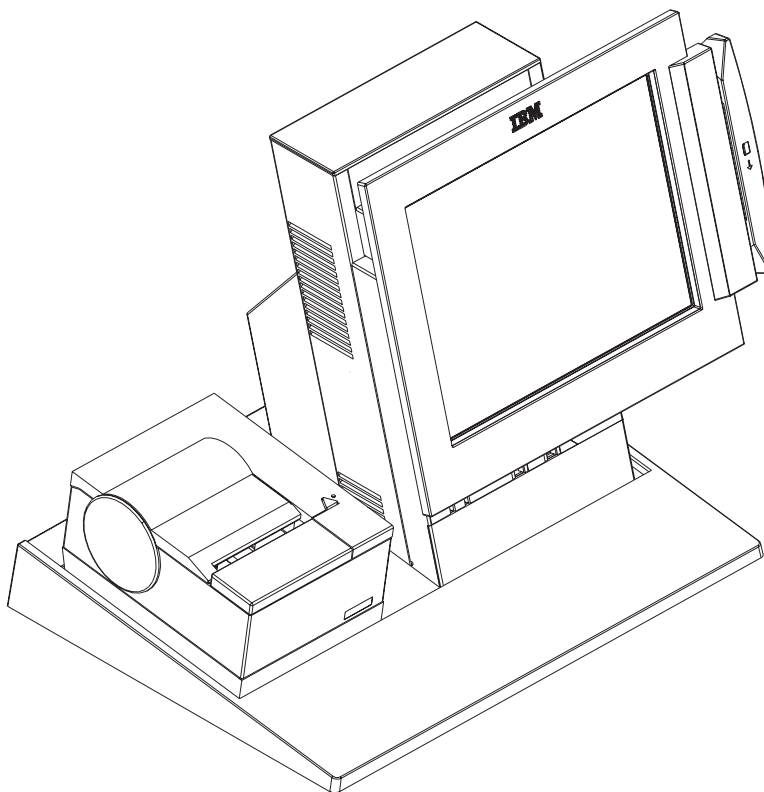

Figure 43. Countertop with non-keyboard-integration tray mounting

The countertop integration tray can be used as a free-standing unit or secured to a countertop using mounting screws. Use the countertop integration tray drawing that comes with it as a pattern for drilling the four mounting holes and for the cable opening, if you plan to route the cables through the countertop. Four screws (not provided) are required to mount the integration tray to a countertop. For specific mounting hole and cutout dimensions, see Figure 44 on page 75.

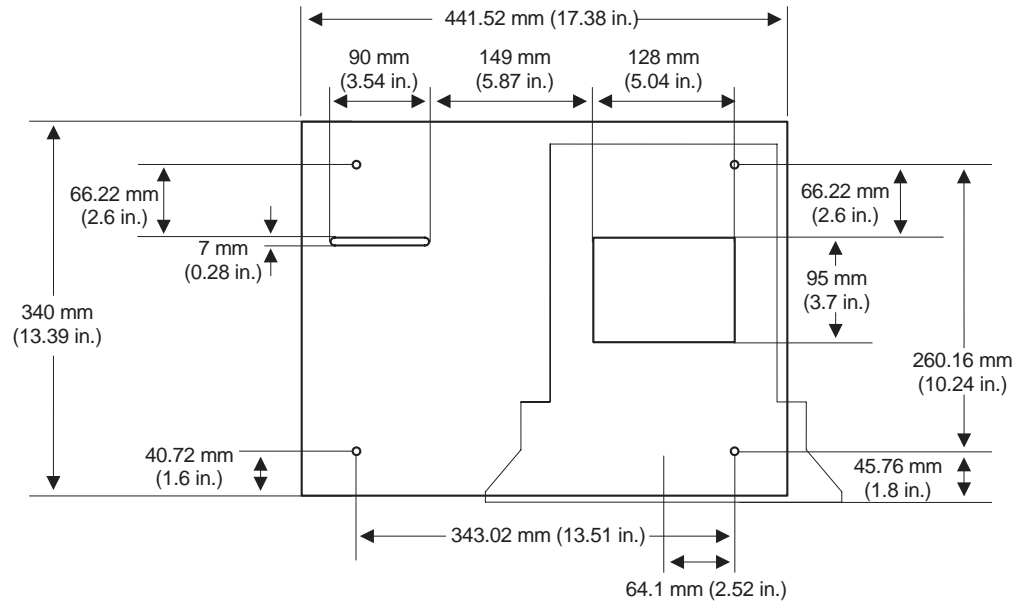

Figure 44. Countertop integration tray pattern with display and countertop cutout on right side

Note: Acquire the four mounting screws before you begin this installation.

1. For a free-standing unit, ensure that the four rubber feet **H** are installed on the bottom of the countertop integration tray (as shown in Figure 47 on page 77).
2. To secure the countertop integration tray to a countertop, perform the following steps:
 - a. Detach the plastic fence from the countertop integration tray. To detach the plastic fence:
 - 1) Spread the rear sides away from the tray as shown in Figure 45.

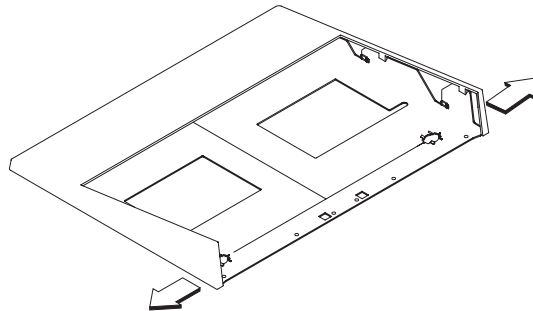

Figure 45. Detaching the fence from the tray

- 2) Alternating from side to side, slide the plastic fence **B** about 7 mm (0.25 in.) until the plastic fence is detached from the metal integration tray **A**, as shown in Figure 46 on page 76.

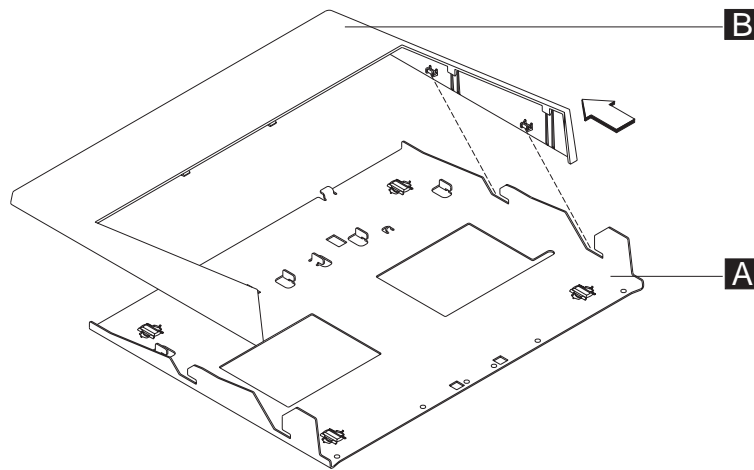

Figure 46. Sliding the fence off of the integration tray

- b. Drill the four mounting holes and cut a hole in the countertop for cables, if needed. Use Figure 44 on page 75 or the openings in the integration tray as a pattern for drilling mounting holes and a cable opening in the counter. See Figure 47 on page 77 for reference.
- c. Remove the four rubber feet located on the bottom of the integration tray. See Figure 47 on page 77 for the location of the feet.
- d. Attach the integration tray to the countertop using four mounting screws, one at each corner of tray. The four mounting screws are *not* provided with the kit. Use 60-mm (0.25-in.), pan-head screws.
- e. Reattach the fence to the integration tray.

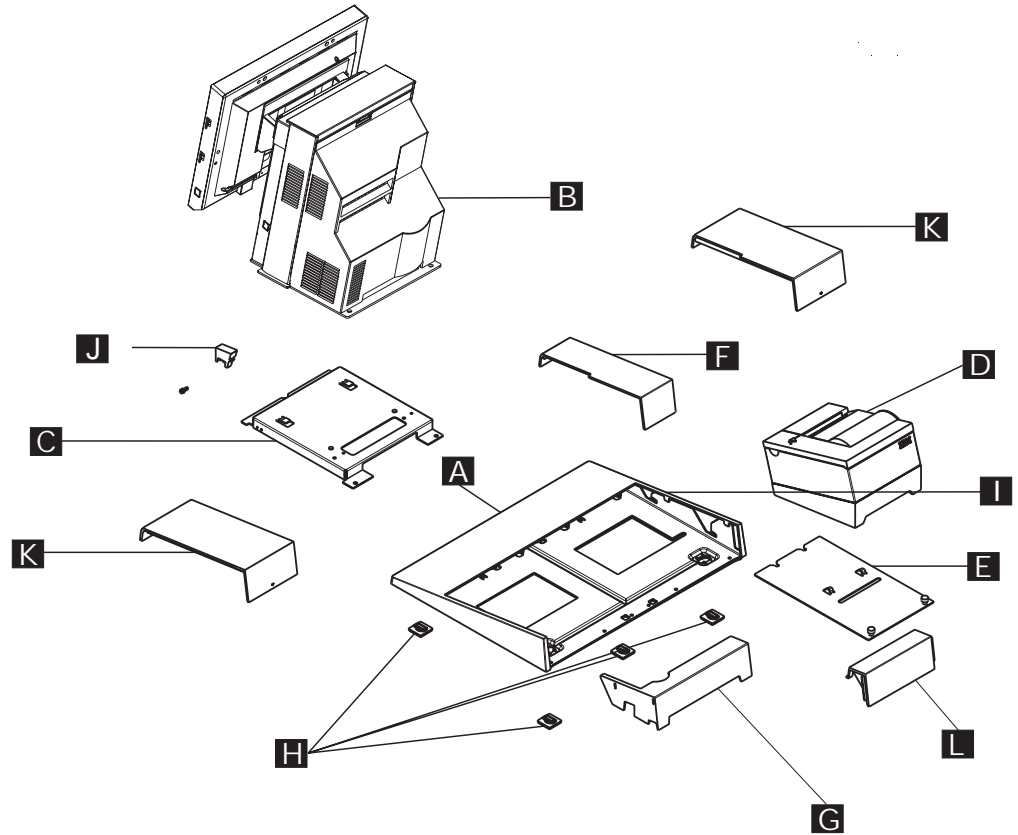

Figure 47. Overview of integration tray, SurePOS 500, printer, and filler panels

Table 16. Countertop integration tray legend

A	Fence	G	System filler panel
B	SurePOS 500	H	Four rubber feet
C	Mounting plate	I	Countertop integration tray
D	4610 SureMark Printer	J	Small filler panel
E	Mounting plate for 4610 SureMark printer	K	Filler panel used when printer is absent
F	Center filler panel	L	Filler panel used when printer is present

3. Remove the rear cover as shown in “Rear cover removal” on page 31.
4. Attach small filler panel **J** to the mounting plate **C**.
5. Remove the base plate and place the unit on the mounting plate **C**.

6. Attach the SurePOS 500 and its mounting plate **C** to the right side of the integration tray **I** as shown in Figure 47 on page 77. Slide the front of the mounting plate under the appropriate pair of tabs on the tray and secure the rear of the mounting plate to the tray with two thumbscrews.
7. Install the IBM 4610 SureMark Printer on the integration tray. Go to “Installing IBM 4610 SureMark Models TF6 or TF7 printers” on page 95 for detailed instructions on mounting plate installation and printer cable routing.
 - a. Attach the printer to its mounting plate as shown in Figure 66 on page 97.
 - b. Install the printer and the printer cables and route the cables as shown in Figure 65 on page 97.
8. Connect the peripheral device cables to the appropriate ports on the rear connector panel. Make the connections on the bottom row of the connector panel first and work upward. Ensure that the cables are routed to the right of the power cord.

Note: For a diagram of the port layout, see “Connectors, power, and brightness controls” on page 5.

9. Use tie-wraps to secure cables to the cable-tie bar, if desired.
10. Replace the rear cover.
11. Plug the AC power cord into an AC outlet.
12. Replace the SurePOS 500 rear cover.
13. Install the filler panels after you route all the cables to your system.
 - a. Install the outer ends of the filler panels **L** and **G** into the integration tray. Notice that the printer filler panel, shown on the right, is narrower than the system filler panel. Also, the system filler panel has a bottom slot that allows you to route the cables out the back.
 - b. Use the narrow filler panel **K** to lock the filler panels together between the system and the printer.

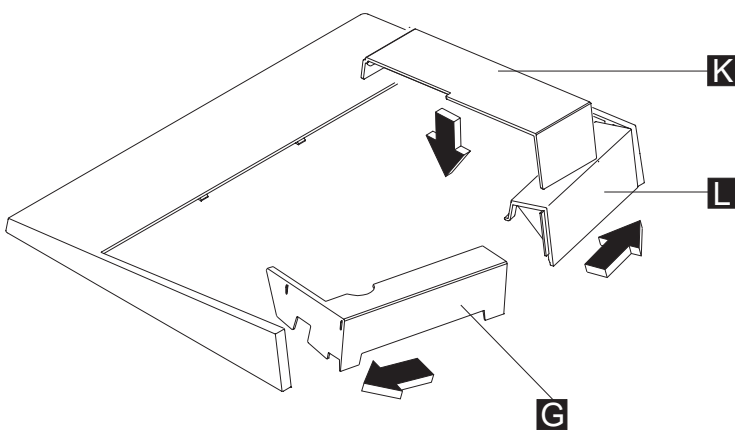

Figure 48. Connecting filler panels

Note: Depending on your desired configuration, you could have unused filler panels.

14. Plug the system and printer AC power cords into an AC outlet.
15. After your installation is complete, press the printer power switch under the printer cover to power On the printer.

16. Switch ON the power to the SurePOS 500. Verify that the system is operating correctly by checking the indicator lights (LEDs) on the front of the touch screen.
17. Install your software. Refer to *IBM SurePOS Model 545 and 565 Operating System Installation Guide*.

Installing filler panels without a printer

For systems without a printer:

1. Install the mounting plate in the **center** of the base using the removable thumbscrews. See Figure 47 on page 77.
2. Install the system unit in the center using the mounting plate. Use system filler **G** and **K**.

Cash drawer

You can mount the SurePOS 500 on a full-size cash drawer by first installing an integration tray on the cash drawer. Follow these steps:

1. To mount the integration tray onto the cash drawer:
 - a. Tilt the integration tray forward, and slide the tabs into the slots near the front of the drawer. Lay the tray down on the cash drawer.
 - b. Attach the cash drawer integration tray to the cash drawer by tightening two M6x8 screws **A** at the rear of tray, as shown in Figure 49.

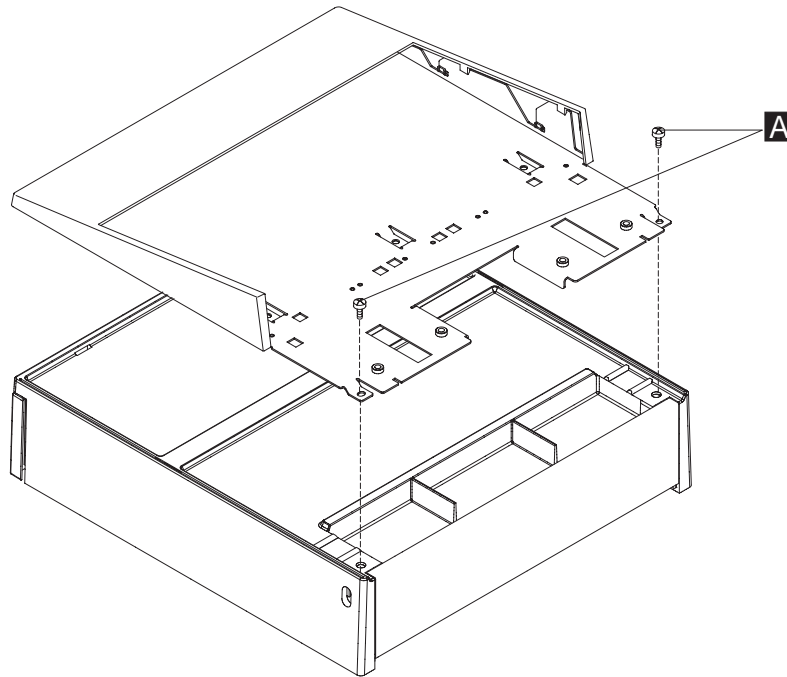

Figure 49. Attaching the integration tray to cash drawer

2. To install the SurePOS 500 on an integration tray:
 - a. Remove the rear cover. "Rear cover removal" on page 31.
 - b. Remove the base plate. See "Base plate – removing and replacing" on page 58.
 - c. Attach the system base to the mounting plate **B** with the screws **C**, as shown in Figure 50.
 - d. Open the rear cash drawer cover **D** by pushing in the two buttons located on each side of the cash drawer. This provides access to the cash drawer connector for cabling it to the system. You will also route cables inside the cover through hole **E** and to the system.

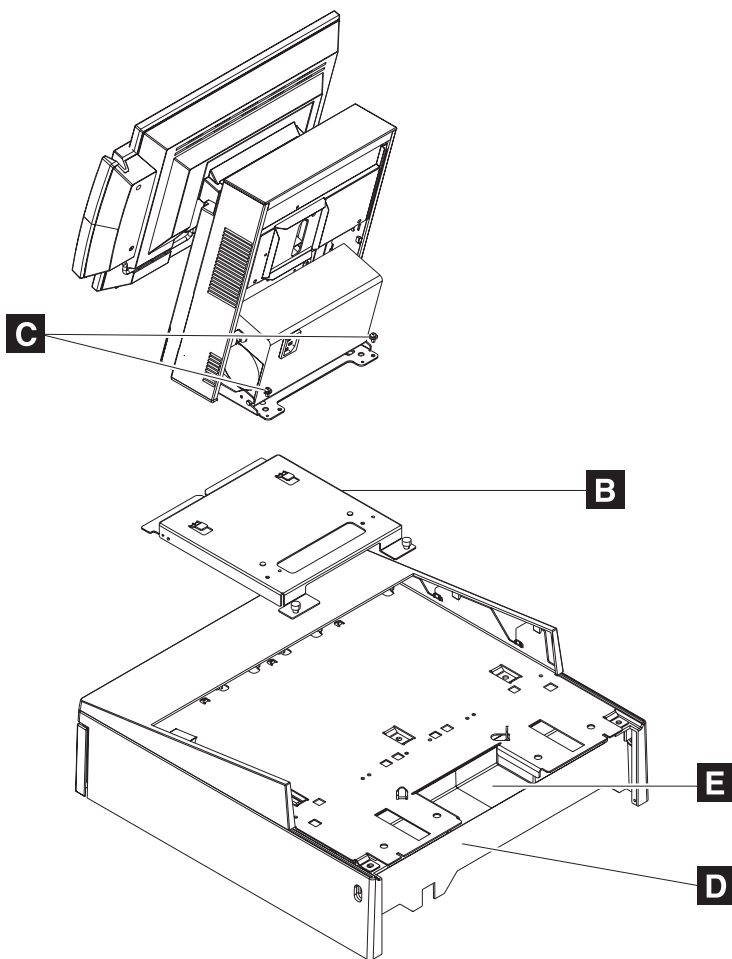

Figure 50. Attaching a mounting plate to center of cash-drawer integration tray

3. For installations **without a printer**, install the mounting plate in the *center* of the base using the removable thumbscrews. Place the filler panels on both sides. See Figure 47 on page 77. Install rear system panel **G** first and use filler panels **K** to lock in filler panel **G** onto the tray.
4. Install the IBM 4610 SureMark printer on the integration tray with the SurePOS 500. Go to "Installing IBM 4610 SureMark Models TF6 or TF7 printers" on page 95 for detailed instructions on printer cable routing, RS-232 printer switch settings, and mounting plate installation:

- a. Plug the data and power cables into the printer, routing the data cable, under the cable tie bar and toward the rear connector panel as shown in Figure 65 on page 97.
- b. Attach the SurePOS 500 Models 545 and 565 base mounting plate **A** to the right side of the integration tray. Slide the front of the plate under the appropriate pair of tabs on the integration tray. Secure the rear of the plate to the tray with two thumbscrews as shown in Figure 51.

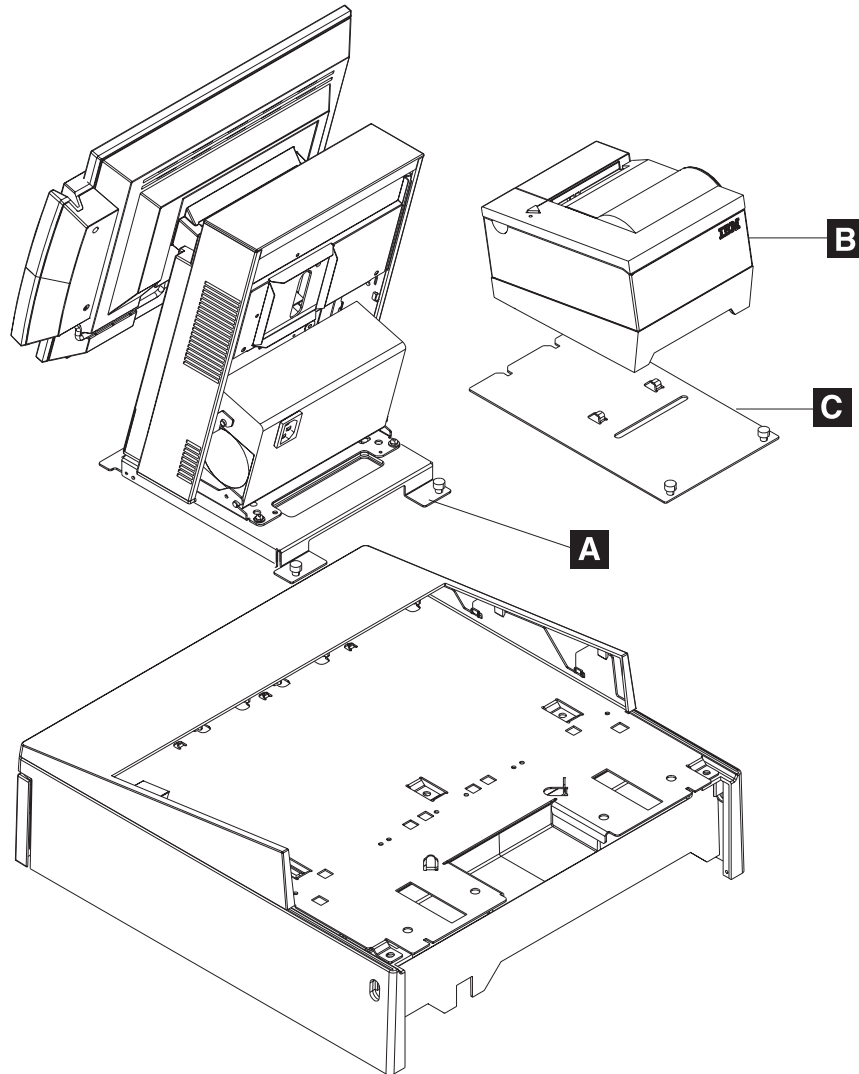

Figure 51. Attaching mounting plate to the cash drawer integration tray

- c. Attach the printer **B** to the printer base mounting plate by sliding it onto the two tabs until it locks in place.
 - d. Attach the printer base mounting plate **C** to the integration tray. Slide the front of the plate under the appropriate pair of tabs on the integration tray. Secure the rear of the plate to the tray with two thumbscrews.
5. Plug the cash-drawer cable into the cash drawer and route it under the cable-tie bar to the rear connector panel.
 6. Plug the data and power cables into the printer, routing the data cable under the cable tie-bar and toward the rear connector panel.

7. Route all cables through the hole at the center rear of the cash drawer. Then route the cables through the rear of the system, laying them flat on top of the cash-drawer integration tray.
8. If you are installing a distributed-character display or an all points addressable (APA) display, see “Mounting a distributed customer display and APA display to a cash drawer” on page 93.
9. Connect the peripheral cables to the appropriate ports on the rear connector panel. See “Connectors, power, and brightness controls” on page 5.

Note: If you are installing a distributed-character display, route the cable through the unattached rear modesty panel **C** in Figure 52 on page 83.

10. Use tie-wraps to secure cables to the cable-tie bar. Be sure to run cables to the right of the power cable when viewed from the rear.
11. Replace the rear cover.
12. See Figure 52 on page 83. Install the filler panels after you route all the cables to your system. Note that filler panel **A** locks filler panels **B** onto the tray. Install the filler panels after you have routed all of the cables.
 - a. Install the outer ends of the filler panels **B** into the integration tray. Notice that the printer filler panel, shown on the right, is narrower than the system filler panel. Also, the system filler panel has a bottom slot that allows you to route the cables out the back.
 - b. Use the narrow filler panel **A** to lock the filler panels together between the system and the printer.

Note: Depending upon your desired configuration, you could have unused filler panels.

13. Tilt the modesty cover **C** so the front hooks attach to the tray; then push down until the cover snaps into place.

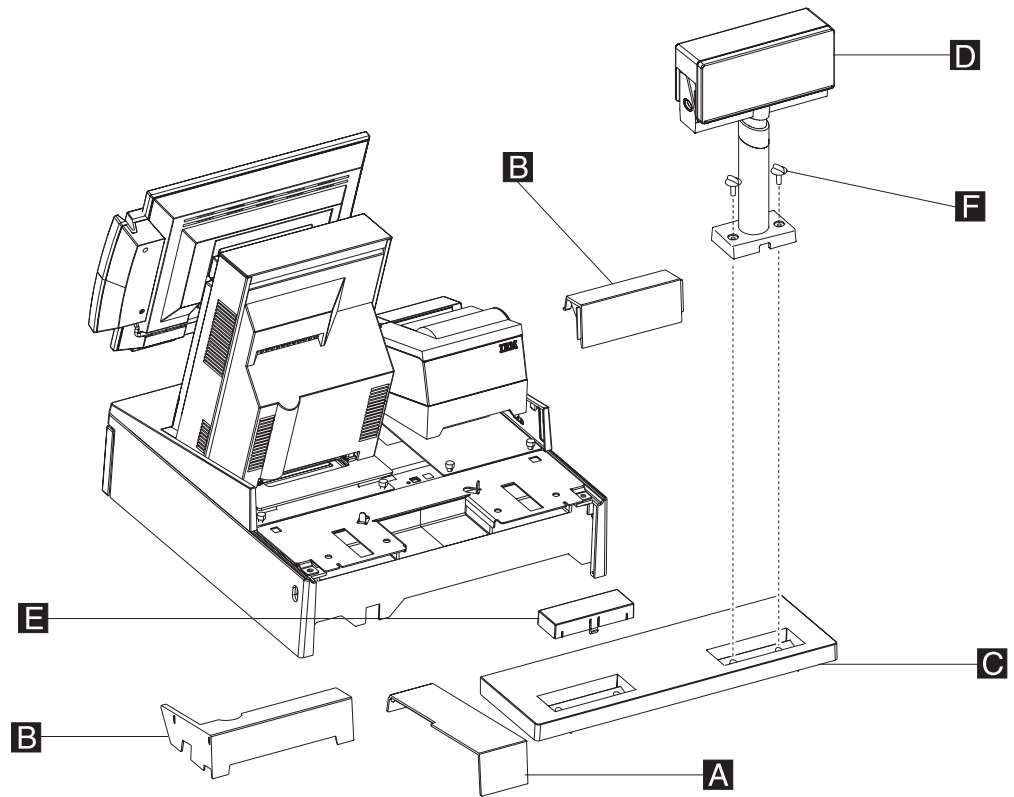

Figure 52. Attaching filler panels and the rear modesty cover

14. Attach the distributed customer display **D** to the cash drawer with two thumbscrews **F** and snap the entire unit into place at the rear of the tray.
15. Close the cash-drawer rear cover.
16. Plug the AC power cords for the printer and the system into an AC outlet.
17. After your installation is complete, press the printer power switch under the printer cover to power on the printer.
18. Switch ON the power to the SurePOS 500. Verify that the system is operating correctly by checking the indicator lights (LEDs) on the front of the system.
19. Install your software. Refer to *IBM SurePOS Model 545 and 565 Operating System Installation Guide*.

Keyboard-integration tray

This section describes how to install a keyboard tray with the SurePOS 500 Models 545 and 565.

Countertop and full-size cash drawer

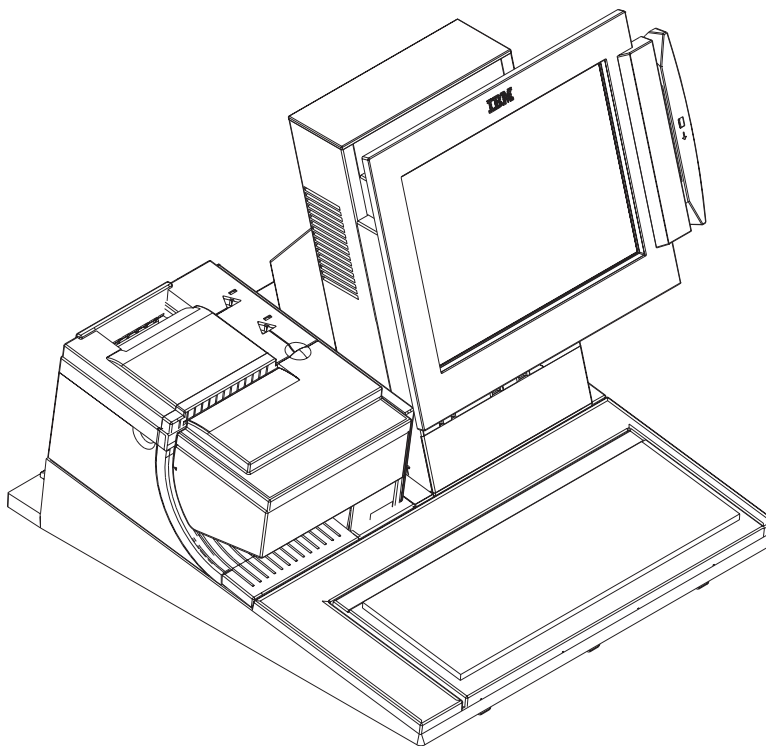

Figure 53. Full-size keyboard-integration tray on a countertop

The full-size keyboard-integration tray can be used as a free-standing unit, secured to a countertop using mounting screws or mounted to a cash drawer. The SurePOS 500 is mounted with the 4610 SureMark printer using the full-size keyboard-integration tray.

Important

Devices such as the printer, integrated character display, and keyboard are mounted the same way when the full-size keyboard-integration tray is used for a countertop or cash drawer mount. Therefore, the instructions for the countertop and cash drawer mount have been combined.

Mounting the integration tray to a countertop

Use the countertop keyboard-integration tray as a pattern for drilling the four mounting holes and for the cable opening, if you plan to route the cables through the countertop.

Note: Four screws (not provided) are required to mount the integration tray to a countertop.

1. Prepare the SurePOS 500 to mount to the keyboard-integration tray:
 - a. Remove the rear cover.

Notes:

- 1) If you are routing cables underneath the counter, route them through the cable-access hole in the counter.
- 2) If you are routing cables on top of the counter, route them out the back of the system. Lay them flat along the countertop.
2. For a free-standing unit, ensure that the four rubber feet **A** are installed on the bottom of the countertop keyboard integration tray (as shown in Figure 54 on page 86).
3. To secure the **full-size keyboard-integration tray to a countertop**, perform the following steps:
 - a. Remove the fence **E** from the countertop keyboard-integration tray by removing the screws as shown in Figure 54 on page 86.
 - b. Drill the four mounting holes and cut a hole in the countertop for cables if needed. Use the openings in the integration tray as a pattern for drilling mounting holes and a cable opening in the counter.
 - c. Remove the rubber feet **A** located on the bottom of the integration tray. See Figure 54 on page 86 for location of feet.
 - d. Attach the keyboard-integration tray to the countertop using four mounting screws, one at each corner of tray. The four mounting screws are not provided with the kit. Use 60-mm (0.25-in.) pan-head screws.
 - e. Reattach the fence **E** to the tray with the six small screws.

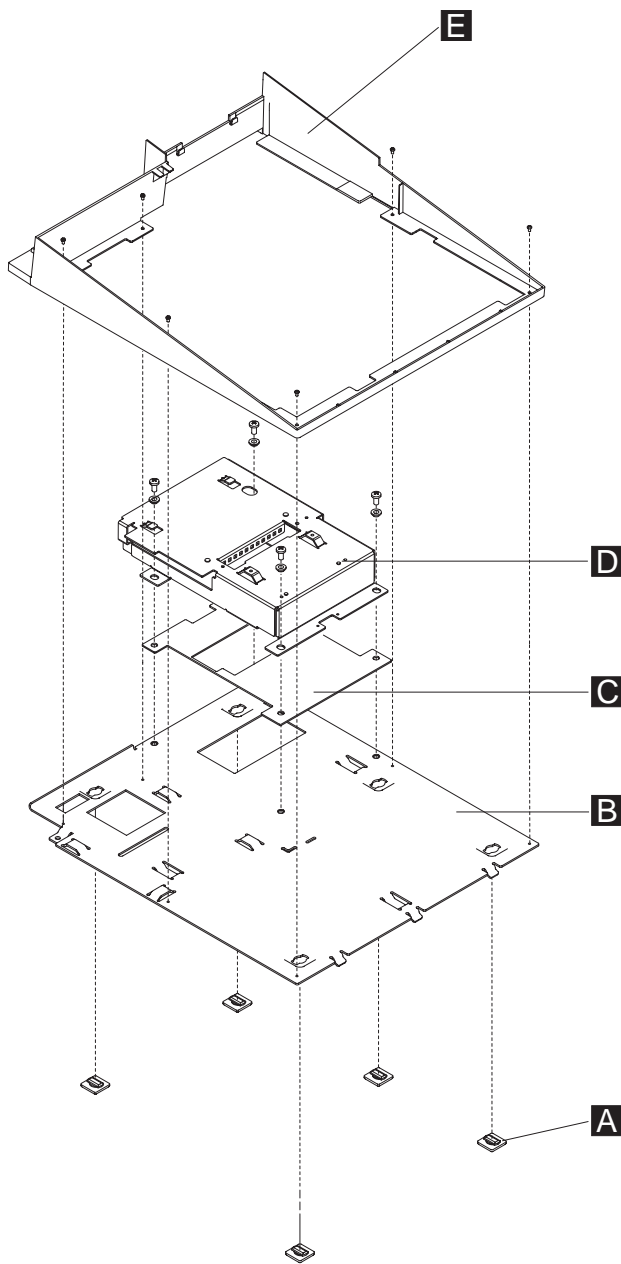

Figure 54. Countertop keyboard-integration tray assembly

Table 17. Countertop integration tray legend

A	Four rubber feet	D	Mounting plate
B	Keyboard-integration tray	E	Fence
C	Insulator plate		

4. Prepare the SurePOS 500 to mount to the keyboard-integration tray:
 - a. Remove the rear cover.

Notes:

- 1) If you are routing cables underneath the counter, route them through the cable-access hole in the counter.
- 2) If you are routing cables on top of the counter, route them out the back of the system. Lay them flat along the countertop.

5. Remove the rear cover on the cash drawer. While pressing in on the two buttons located on the sides of the cash drawer, pull back on the rear cover to remove it. Discard this rear cover. A new rear cover is used for installation of the keyboard integration kit.
6. Install the keyboard-integration tray on a cash drawer:

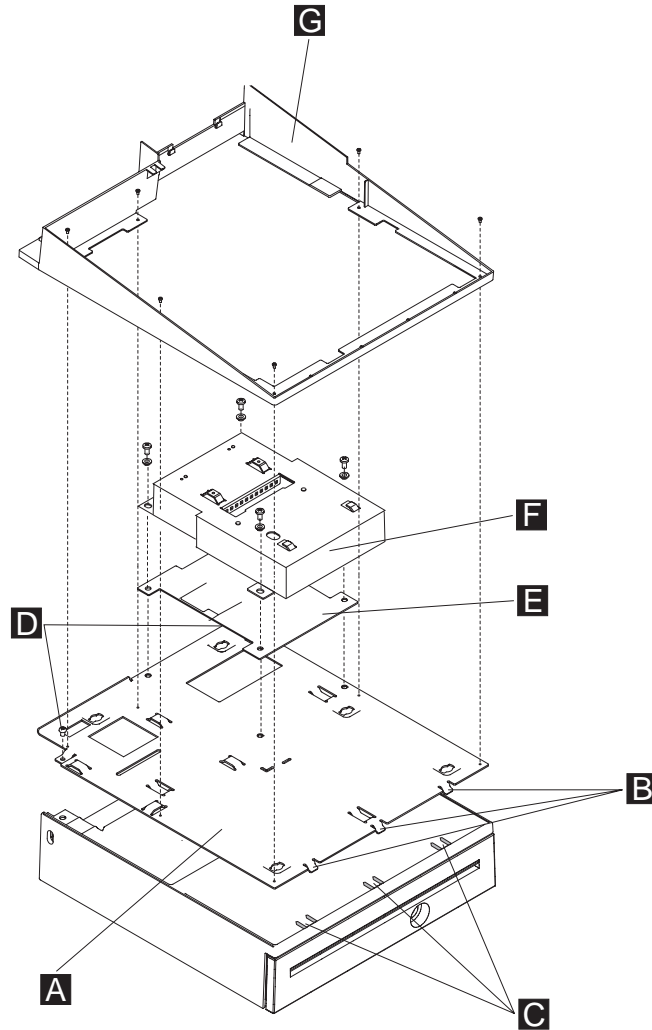

Figure 55. Installing the keyboard-integration tray on a cash drawer

- a. Tilt the integration tray down so the three tabs **B** align with the three tab holes **C** on the cash drawer as shown in Figure 55. Set the integration tray down on the cash drawer while aligning the screw holes **D** with holes on the cash drawer.
- b. Secure the integration tray to the cash drawer with two screws at location **D**.
7. Attach the mounting plate **F** to the integration tray with four plastic washers and screws as shown in Figure 55.
8. Attach the fence **G** to the integration tray with six small screws.
9. Remove the base plate. See “Base plate – removing and replacing” on page 58.
10. Attach the SurePOS 500 to the mounting plate as shown in Figure 56 on page 88. Slide the unit from the back toward the front until the frame fits into the

tabs **B**, and the screws **A** and mounting holes **C** are lined up. Tighten the two base-bracket screws.

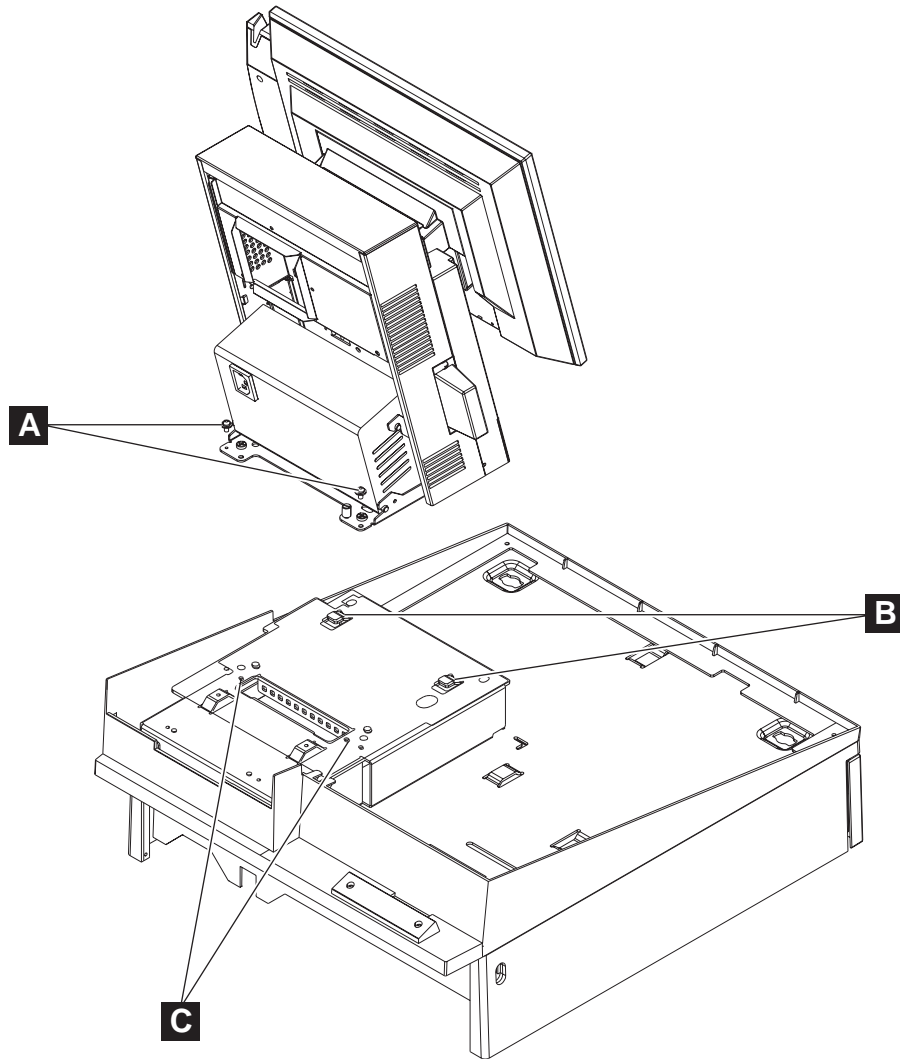

Figure 56. Installing the SurePOS 500 onto the integration tray

11. Install the IBM 4610 SureMark printer on the integration tray, by performing the following steps:

Note: See the *4610 SureMark Point-of-Sale Printers User's Guide* for detailed information about switch settings and cabling for the printer.

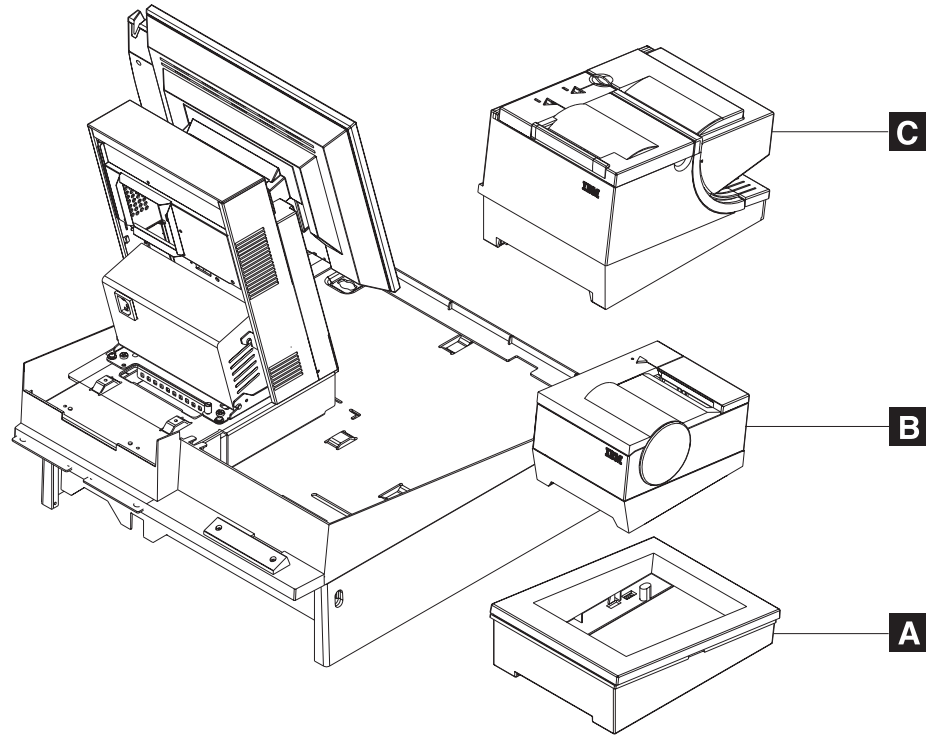

Figure 57. Installing the 4610 printer onto the integration tray

Table 18. 4610 SureMark printer on a full-size keyboard-integration tray legend

A	Printer stand for the 4610 Models TF6 and TF7 printers
B	4610 Models TF6 and TF7 printers (small footprint)
C	4610 Models TG3, TG4 and TG5 printers

- a. Install the printer cables and route the cables as shown in Figure 65 on page 97.
 - For the small-footprint 4610 SureMark Models TG3, TG4 and TG5 printers **B**, first insert the plastic printer base **A** onto the integration tray and then place the printer into the printer base.
 - For the large-footprint 4610 SureMark Model TG3 and TG4 printers, place the printer directly onto the integration tray.

12. To install the keyboard, perform the following steps. See Figure 58 for callout locations:

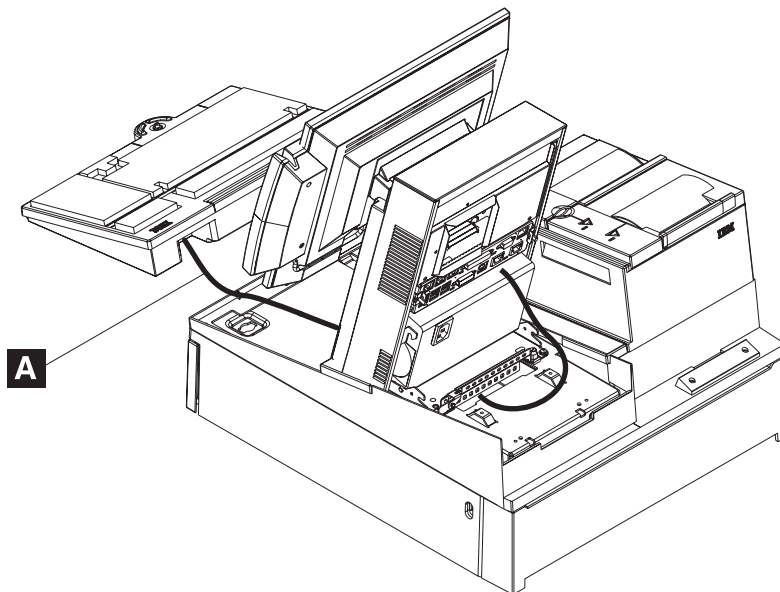

Figure 58. Installing the keyboard onto the integration tray

- a. Attach the keyboard cable **A** to the IBM PS/2[®] port on the rear connector panel.
 - b. Place the keyboard on the integration tray while pushing the excess keyboard cable back under the filler panel.
13. Prepare the distributed customer display to be installed on an integration tray.
 - a. Route the distributed customer display cable through the mounting post (and post extension, if used) and plug the cable into the display.

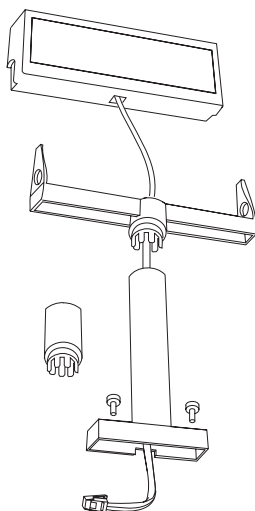

Figure 59. Attaching the distributed customer display cable

- b. Attach the character display's top to its post by pressing the display down on the post until it snaps into place.

14. To install a distributed customer display or an APA display, perform the following steps:

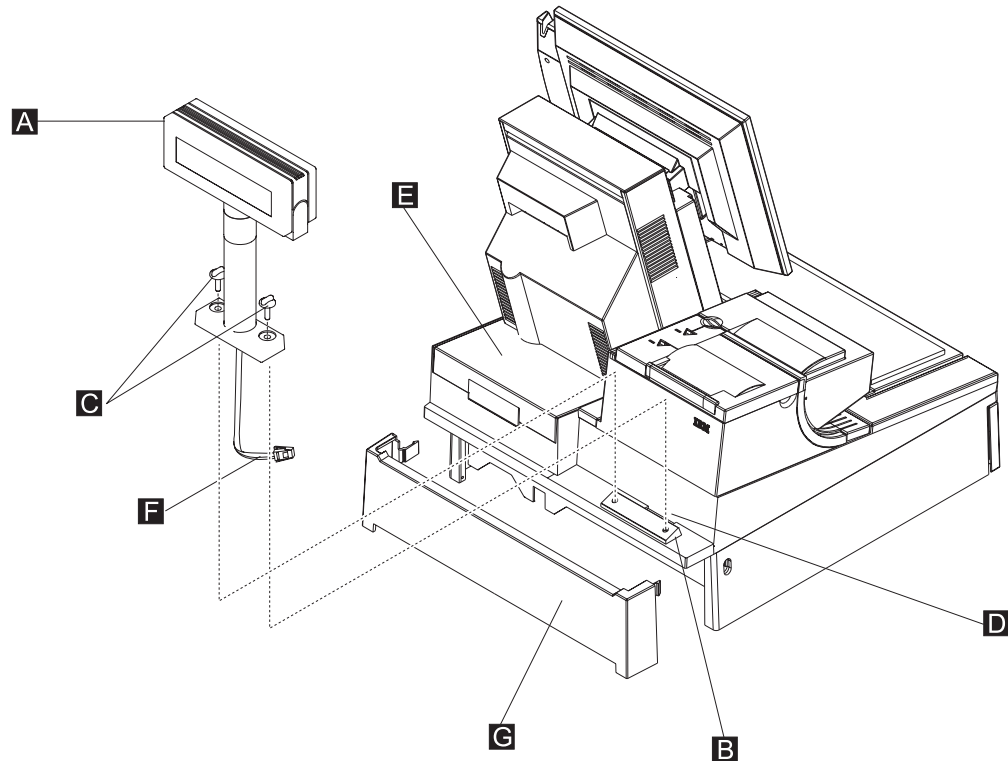

Figure 60. Installing the distributed customer display onto the integration tray

- a. Route the display cable **F** through hole **D**, as shown in Figure 60. You might need to place the display on its side to connect the display cable to the system unit rear connector panel.
 - b. Route the display cable to the rear connector panel, passing it under the cable-tie bar, and plug it into the 15-pin serial connector.
 - c. Attach the distributed customer display **A** to the cash drawer at location **B** with two thumbscrews **C**.
15. Plug the AC power cord to the power supply.
16. Connect the peripheral cables to the appropriate ports on the SurePOS 500 rear connector panel. Make the connections on the bottom row of the panel first and work upward. See “Connectors, power, and brightness controls” on page 5.

Notes:

- a. If you are routing the cables under the counter, route all cables (including the AC power cord) through the cable-access hole.
 - b. If you are routing the cables on top of the counter, route all cables out the rear of the system. Lay the cables flat along the countertop.
17. Use tie-wraps to secure cables to the integration tray.
18. Replace the rear cover and install the rear filler panel.
19. Attach the cash-drawer rear cover by aligning the tabs with the buttons, and push in on the cover.
20. Plug the system and printer AC power cords into an AC outlet.

21. After your installation is complete, press the printer power switch under the printer cover to power on the printer.
22. Switch ON the power and verify that the system is operating correctly by checking the indicator lights (LEDs) on the front of the touch screen.
23. Install your software. Refer to *IBM SurePOS Model 545 and 565 Operating System Installation Guide*.

Installing additional peripheral devices

Attention: Before you use the following procedures to install additional peripheral devices, see “Safety Information” on page xi.

Mounting a distributed customer display and APA display to a cash drawer

The SurePOS 500 Models 545 and 565 provides a powered, 15-pin, serial port for attaching a distributed customer display, APA character-graphic display, or other device requiring a powered serial connection. The SurePOS 500 Models 545 and 565 distributed customer display is mounted behind the cash-drawer modesty panel. It can also be mounted to a countertop with customer-provided hardware. Use these instructions to mount a character display to a cash drawer.

1. Prepare the system for installation of the distributed customer display.
 - a. Switch OFF the power at the system unit.
 - b. Remove the SurePOS 500 Models 545 and 565 rear cover (see “Rear cover removal” on page 31) to access the rear connector panel.
2. Prepare the distributed customer display to be installed on an integration tray.
 - a. Route the distributed customer display cable through the mounting post (and post extension, if used) and plug the cable into the display, as shown in Figure 61.

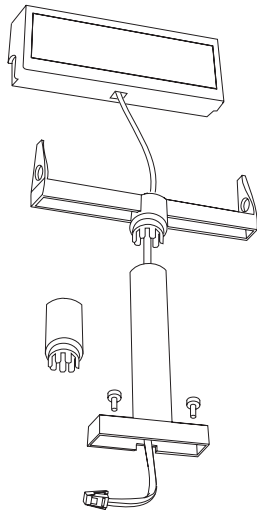

Figure 61. Attaching the distributed customer display cable

- b. Attach the character display top to its post by pressing the display down on the post until it snaps into place.
3. Go to the appropriate procedure for a non-keyboard integration tray or keyboard integration tray to complete the installation of the distributed customer display:
 - For installation of a distributed customer display on a non-keyboard integration tray, go to Step 4 on page 94.
 - For installation of a distributed customer display on a keyboard integration tray, go to Step 5 on page 95.

4. To install a distributed customer display **D** on a non-keyboard integration tray, perform the following steps:
 - a. Remove the filler panels **A** and **B** (two) and the rear modesty panel **C** from the integration tray, as shown in Figure 62.

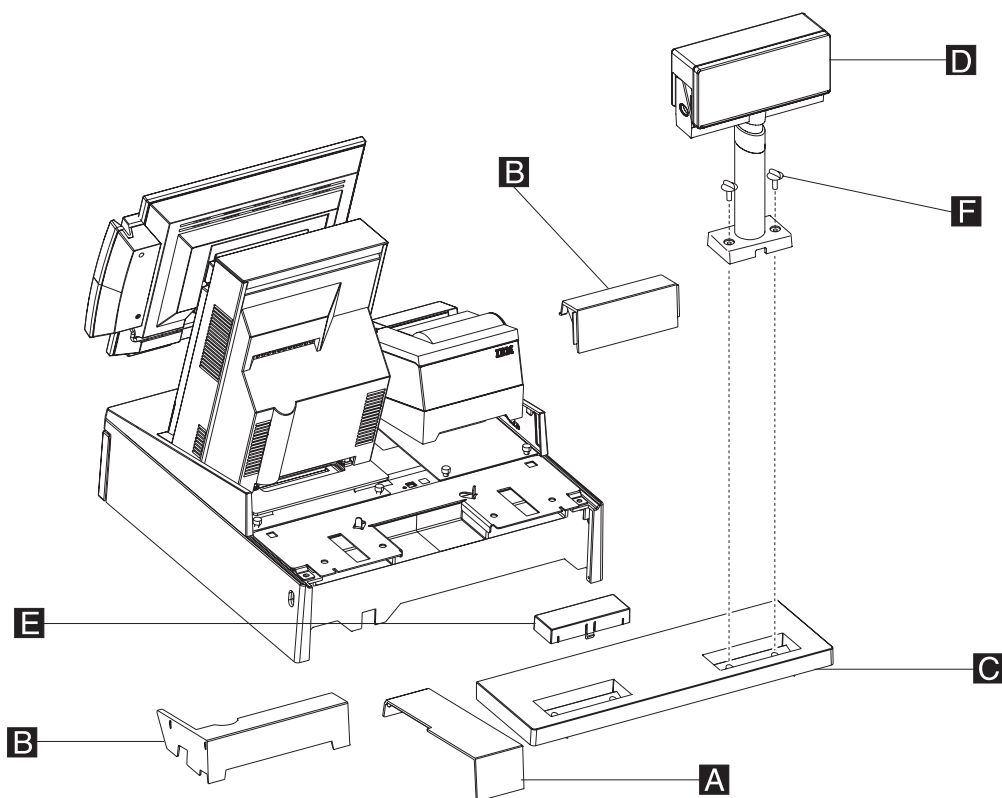

Figure 62. Attaching the distributed customer display to the system unit

- b. Remove one of the two plugs **E** in the rear modesty panel. Figure 62 shows one plug removed.
- c. Route the character display cable through the hole in the modesty panel. You may need to lay the display on its side to connect the display cable to the rear connector panel.
- d. Route the character display cable to the rear connector panel. Plug it into the 15-pin serial connector.
- e. Reinstall the rear cover of the SurePOS 500 Model 514 (see “Rear cover removal” on page 31).
- f. Reinstall the filler panels **B**, and then install **A**, as shown in Figure 62.
- g. Attach the post, through the modesty cover **C** to the cash drawer with 2 thumbscrews **F**. Snap the entire unit into place at the rear of the tray.

5. To install a distributed customer display on a keyboard integration tray, perform the following steps:
 - a. Route the character display cable through the hole behind mounting post as shown in Figure 63. You might need to lay the display on its side to connect the display cable to the system unit rear connector panel.

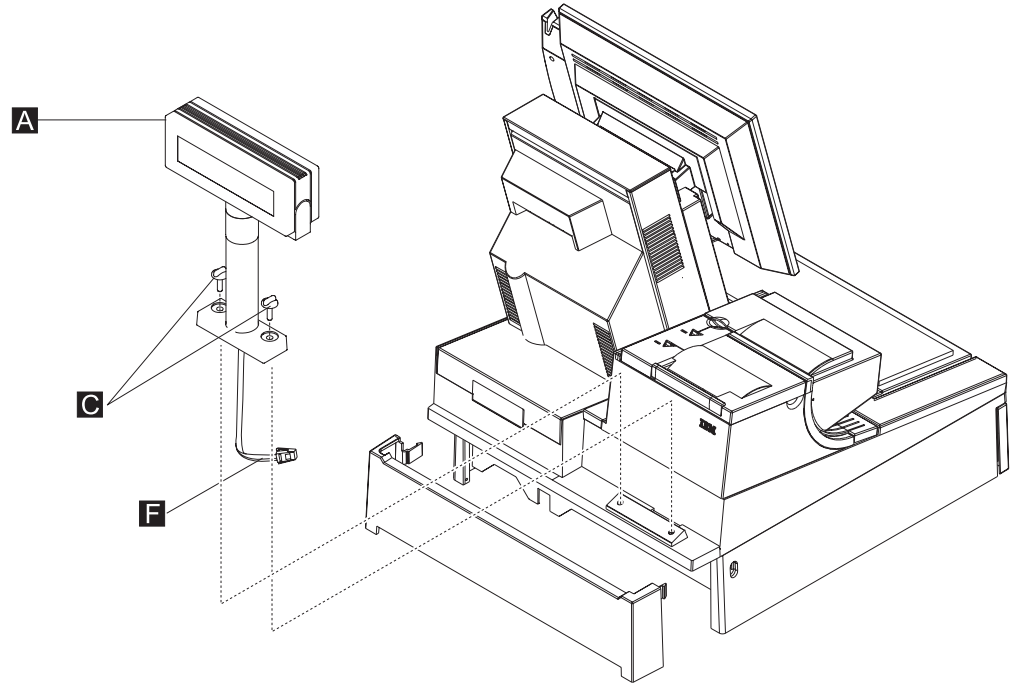

Figure 63. Installing the distributed customer display onto the keyboard integration tray

- b. Route the distributed customer display cable **F** to the rear connector panel, passing it under the cable-tie bar. Plug it into the 15-pin serial connector.
- c. Attach the distributed customer display **A** to the cash drawer mounting post with two thumbscrews **C**. Snap the entire unit into place at the rear of the tray, as shown in Figure 63.

Installing IBM 4610 SureMark Models TF6 or TF7 printers

Note: Service for the IBM SurePOS Model 4951, Model 514 includes the IBM 4610 SureMark printer.

The IBM 4610 SureMark Model TF6 and TF7 (4610 TF6 or TF7) are the smaller 4610 models that contain only a thermal customer receipt station. These models do not support document printing. For detailed information about these printers, see the *IBM 4610 SureMark Point-of-Sale Printers User's Guide*.

The 4610 TF6 or TF7 can be installed as a freestanding unit, attached to a countertop integration tray, or attached to a cash drawer integration tray. Attaching the 4610 TF6 or TF7 to a non-keyboard integration tray is different than attaching it to a keyboard integration tray:

- For the non-keyboard integration tray, the 4610 TF6 or TF7 is attached to a mounting plate and then attached to the non-keyboard integration tray.

- For the keyboard integration tray, the 4610 TF6 or TF7 is set into a plastic printer base and then set on the keyboard integration tray.

Figure 64 shows the 4610 TF6 or TF7 printer connectors.

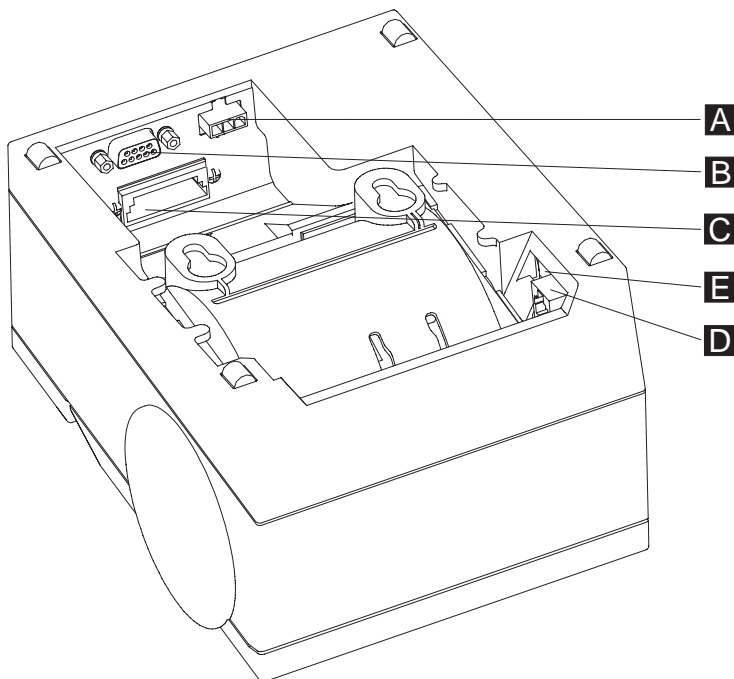

Figure 64. 4610 TF6 or TF7 printer connector locations

- | | | | |
|----------|--|----------|-----------------------|
| A | Power supply port (RS-232 only) | D | Cash drawer connector |
| B | RS-232 port or Powered USB port | E | RS-232 mode switch |
| C | (Not used on the SurePOS 500 Models 545 and 565) | | |

To install the 4610 TF6 or TF7 printer, perform the following steps:

1. Switch OFF the power at the system unit.
2. Remove the SurePOS 500 rear cover (see “Rear cover removal” on page 31).
3. Check the printer RS-232 mode-switch setting for the printer. It is near the rear cable connections. See **E** in Figure 64 for switch location. For switch settings, see the *IBM 4610 SureMark Point-of-Sale Printers User’s Guide*.
4. Connect and route the RS-232 communication cable or Powered USB cable **A** and the power supply cable **B** as shown in Figure 65 on page 97.

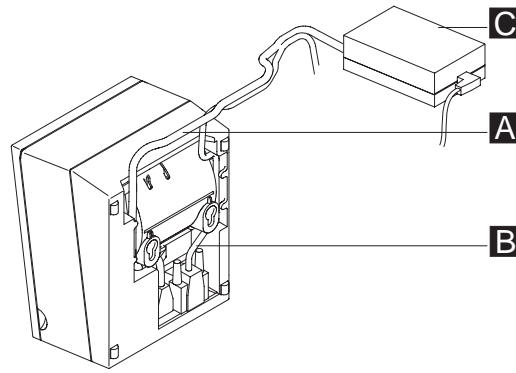

Figure 65. Attaching and routing the cables to the printer.

5. Connect any other signal cables for I/O devices to the correct ports.
6. If you are installing a freestanding printer, route the cables to the rear connector panel on the SurePOS 500 Models 545 and 565 system unit. Pass the cables under the cable-tie bar, and plug it into one of the standard serial ports.
7. Go to the appropriate procedure for non-keyboard integration tray or keyboard integration tray mounting of the 4610 TF6 or TF7 printer:
 - If you are installing a 4610 TF6 or TF7 printer on a non-keyboard integration tray, continue with Step 8.
 - If installing a 4610 TF6 or TF7 printer on a keyboard integration tray, continue with Step 11 on page 88.
8. To install a 4610 TF6 or TF7 printer on a non-keyboard integration tray, perform the following steps:
 - a. Attach the printer mounting plate to the bottom of the printer. The mounting plate slides into the two bottom slots of the printer.

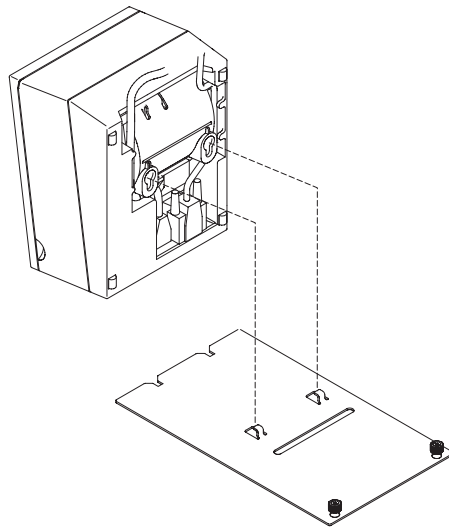

Figure 66. Attaching the 4610 TF6 or TF7 printer mounting plate for a non-keyboard integration tray

- b. The procedure for mounting the printer to a non-keyboard integration tray is the same for countertop or cash drawer. With the mounting plate attached to the printer, slide the front of the printer mounting plate into the slots located

toward the front of the integration tray. Secure the printer by tightening the two thumbscrews on the mounting plate to the tray.

- c. Route the RS-232 cable **A** to the rear connector panel of the system unit as shown in Figure 67. Plug it into one of the three standard serial ports on the system unit.
- d. Route the printer power cord **B** toward the system and out through the hole in the integration tray, as shown in Figure 67.

Note: When routing the printer and power cables, make sure that the cables are routed inside the mounting plate screws to enable correct installation of the filler panels.

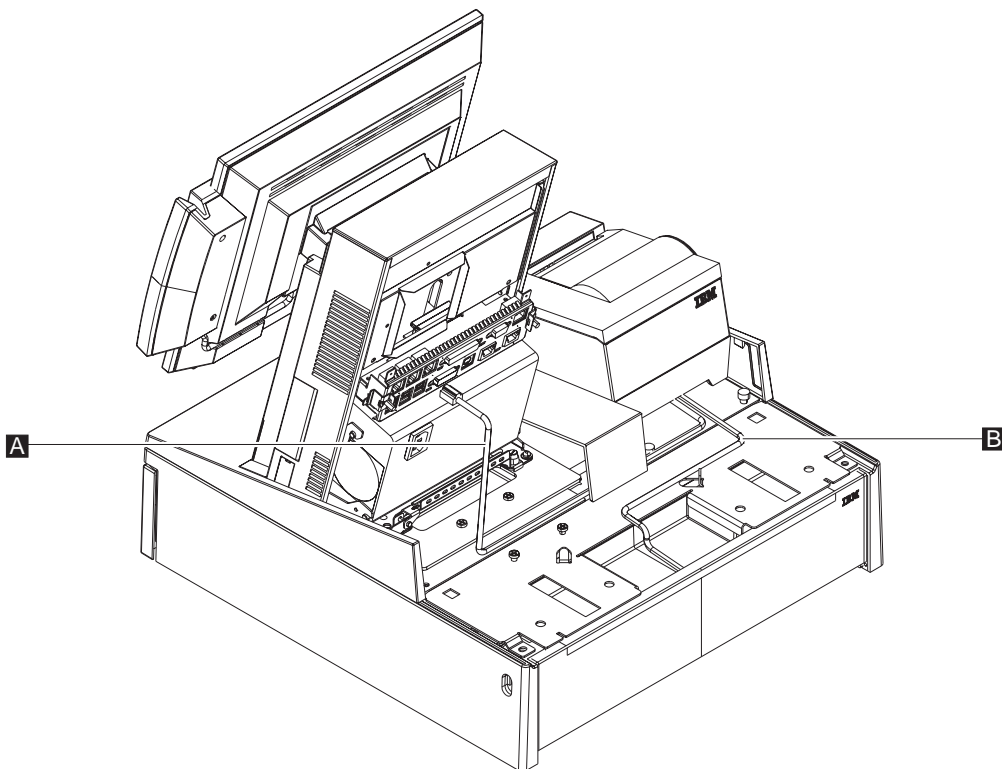

Figure 67. 4610 TF6 or TF7 cable routing

Appendix A. Field replaceable units

How to use the FRU catalog	99
Assembly 1: Models 545 and 565	100
Assembly 2: Countertop and cash drawer keyboard integration tray and filler panels.	104
Assembly 3: Optional peripherals.	106
Assembly 4: Countertop non-keyboard integration tray and filler panels.	108
Assembly 5: Cash drawer non-keyboard integration tray and filler panels	110

This chapter contains field-replaceable part number information the SurePOS 500 Models 545 and 565.

How to use the FRU catalog

This parts listing contains reference drawings and a corresponding index for all field replaceable parts. The index provides the part number, the quantity required (units), and a description of the part.

Listed below is additional information about the parts assembly index.

SIMILAR ASSEMBLIES

If two assemblies contain a majority of identical parts, they are broken down on the same list. Common parts are shown by one index number. Parts specific to one or the other of the assemblies are listed separately and identified by description.

- AR** (As Required) in the Units column indicates that the quantity is not the same for all machines.
- NP** (Non-Procurable) in the Units column indicates that the part is non-procurable and that the individual parts or the next higher assembly should be ordered.
- NR** (Not Recommended) in the Units column indicates that the part is procurable, but not recommended for field replacement, and that the next higher assembly should be ordered.
- R** (Restricted) in the Units column indicates the part has a restricted availability.

INDENTURE

The indenture is marked by a series of dots located before the parts description. The indenture indicates the relationship of a part to the next higher assembly.

- No Dot** Main assembly
- One Dot** Detail parts of a main assembly
- One Dot** Subassembly of the main assembly
- Two dots** Detail part of a one-dot subassembly
- Two dots** Subassembly of a one-dot subassembly
- Three dots** Detail part of a two-dot subassembly

Assembly 1: Models 545 and 565

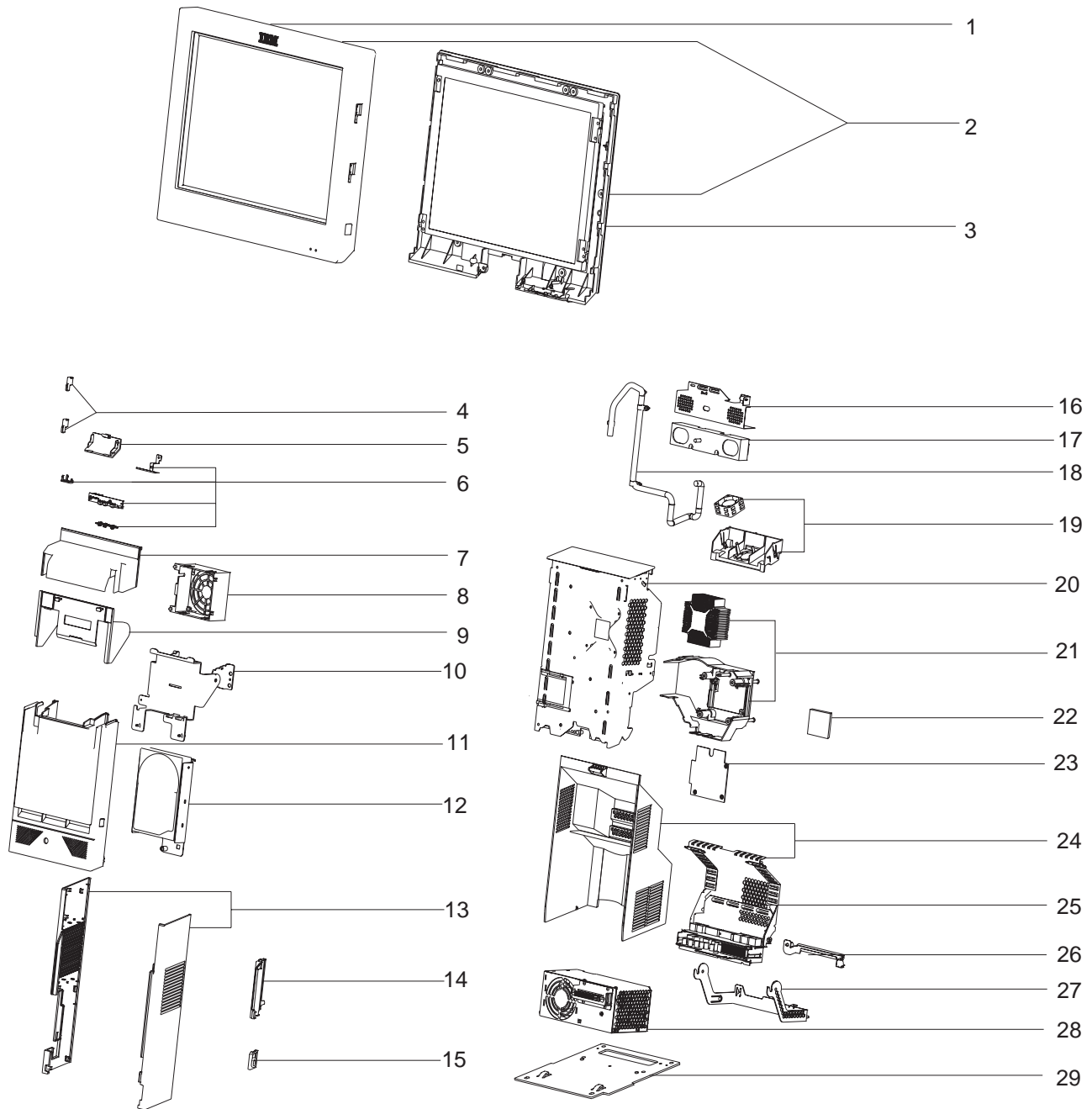

Asm-Index	Part Number	Units	Description
1-1	42V3886		Front bezel assembly, 12 in.
-1	42V3887		Front bezel assembly, 15 in.
-1	42V3888		Front bezel assembly, 17 in.
-2	12X1000		Tablet assembly, 12 in.
-2	12X1001		Tablet assembly, 15 in.
-2	12X1002		Tablet assembly, 17 in.
-3	42V3889		LCD assembly, 12 in.
-3	42V3890		LCD assembly, 15 in.
-3	42V3891		LCD assembly, 17 in.
-4	42V3897		MSR hole plug
-5	42V3893		Touch cable door, 12 in.
-5	42V3894		Touch cable door, 15 in.
-5	42V3895		Touch cable door, 17 in.
-6	42V3892		Operator card kit, 12 in., 17 in.
-6	12X1036		Operator card kit, 15 in.
-7	42V3924		Top, center cover kit
-	41D0171		Power button cover
-8	42V3937		Processor fan/fan bracket
-9	42V3925		Hinge cover, 12 in. and 15 in.
-9	42V3926		Hinge cover, 17 in.
-10	42V3922		Hinge, 12 in. and 15 in.
-10	42V3923		Hinge, 17 in.
-11	42V3927		HDD cover with speaker (model 565, E65 only)
-11	42V3928		HDD cover, no speaker (model 545, E45 only)
-12	42V3943		HDD assembly (HDD, bracket, 4 screws)
-	42V3980		HDD bracket
-	41A3641		HDD
-	42V3944		HDD cable kit
-13	42V3931		Side cover kit
-14	42V3950		PC card door
-15	42V3953		Audio port cover
-16	42V3930		Speaker ESD shield (model 565, E65 only)
-17	40N5755		Speaker (model 565, E65 only)
-18	42V3945		Tablet cable, 12 in. and 15 in.
-19	42V3936		HDD fan kit (bracket, fan, cable)
-18	42V3946		Tablet cable, 17 in.
-	42V3969		System board tray
-20	42V3948		System board assembly, no audio, no PCMCIA (model 545, E45 only)
-20	42V3949		System board assembly, audio, PCMCIA (model 565, E65 only)
-21	42V3938		Processor heat sink
-	42V3939		Processor 2.53 GHz
-22	39X8908		Modular flash drive
-23	12X1009		Video card
-24	12X1110		Rear cover
-25	42V3935		Tailgate assembly
-	42V3947		Speaker extension cable (model 565, E65 only)
-26	42V3932		Cable tie bar
-27	42V3933		Power supply latch arm
-28	42V3682		Power supply
-	42V3951		Power supply EMC shield
-29	42V3940		Base, 12 in. and 15 in.
-29	42V3941		Base, 17 in.
-	45P6222		Battery

Asm- Index	Part Number	Units	Description
-	42V3952		Screw kit
-	42V3956		Memory, 512 MB
-	42V3957		Memory, 1 GB
-	41D9746		USB memory key

Assembly 2: Countertop and cash drawer keyboard integration tray and filler panels

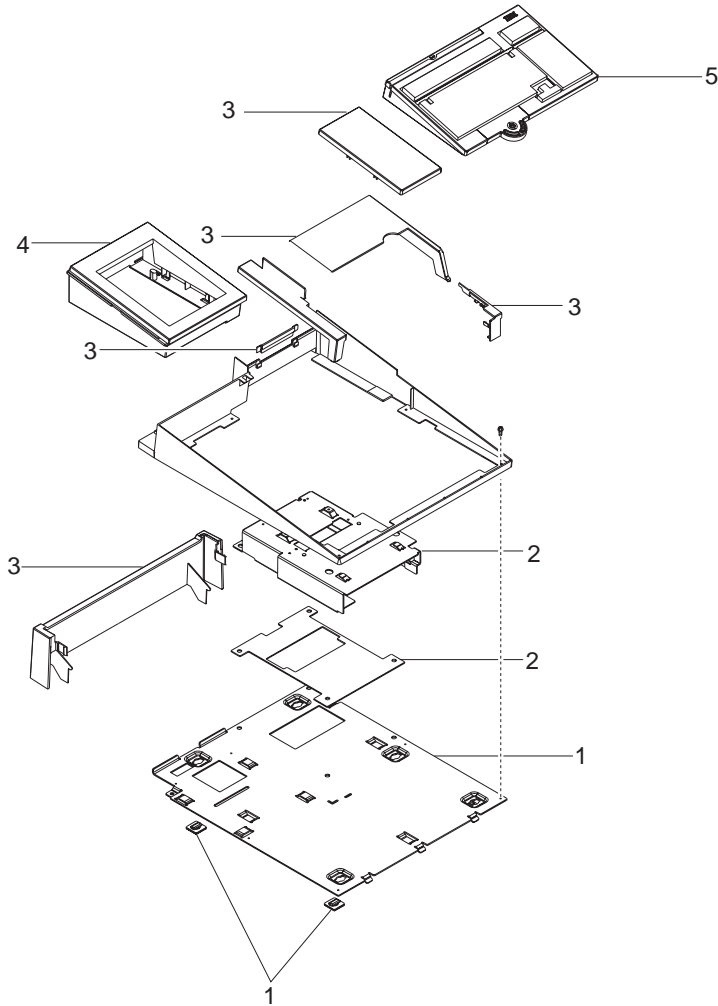

Asm- Index	Part Number	Units	Description
2-			Countertop and cash drawer keyboard integration tray and filler panels
-1	41D0214	1	FRU, plate/fence ASM, wide cash drawer or countertop (includes hardware)
-		1	• ASM, wide cash drawer plate (includes hardware)
-		1	• - M6X8 screws, cash drawer mount
-		1	• - Fence, wide
-		1	• - M3X5 screws, fence mounting
-		1	• - Feet, rubber
-2	42V3964	1	FRU, plate ASM, terminal mounting
-		1	• ASM, terminal mount
-		1	• - Plate, terminal mount insulator
-		1	• - Washer, insulating
-		1	• - M6X12 screws, terminal mount
-3	42V3965	5	FRU, filler panels, wide and countertop
-		1	• Cover, keyboard filler, retail keyboard
-		1	• Cover, terminal filler, wide tray and countertop
-		1	• Cover, wide CD rear curtain
-		1	• Fence, plug
-4	47P9273	1	FRU, iron gray printer footprint adapter, SST to 4610
-		1	• ASM, iron gray printer footprint adapter
-		1	• - Base, SST to 4610 footprint, iron gray
-		1	• - Panel, SST to 4610 footprint, iron gray
-		1	• - Feet, printer base
-	41D0216	1	FRU, retail integration, installation hardware kit (not shown)
-		1	• Hardware kit, retail integration
-		1	• - M3X5 screws, fence mounting (6)
-		1	• - M5X10 screws, system unit mounting (4)
-		1	• - M6X12 screws, terminal mounting (4)
-		1	• - Washer, insulation (for terminal mount screws) (4)
-		1	• - M6X8 screws, CD plate mounting (4)
-		1	• - Feet, CD plate countertop mounting (5)
-5	14R0157		Wide keyboard filler panel. See the "CANPOS keyboard with integrated pointing devices" description in the <i>Options and Input/Output Service Guide</i> , publication GC30-9737.

Assembly 3: Optional peripherals

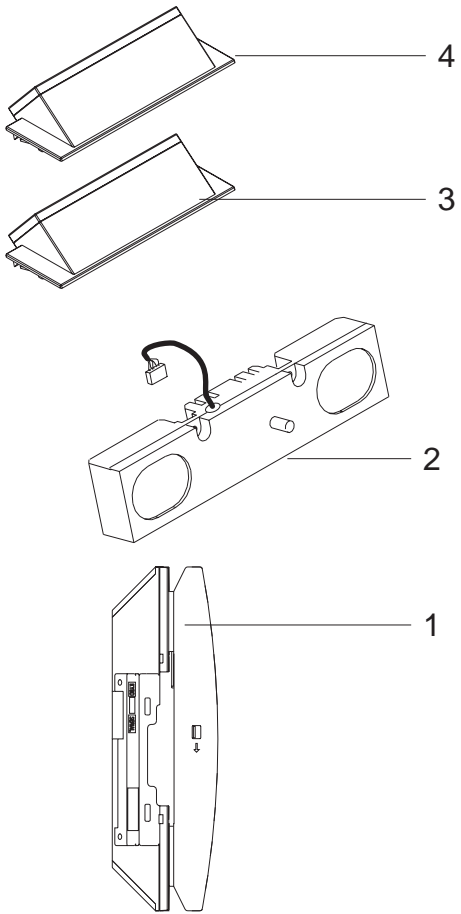

Asm- Index	Part Number	Units	Description
3-1	42V3960		MSR, 3-track
-1	42V3961		MSR, JUCC
-2	42N5755		Speaker
-3	42V3958		Display, integrated 2x20
-4	42V3959		VFD housing, integrated

Assembly 4: Countertop non-keyboard integration tray and filler panels

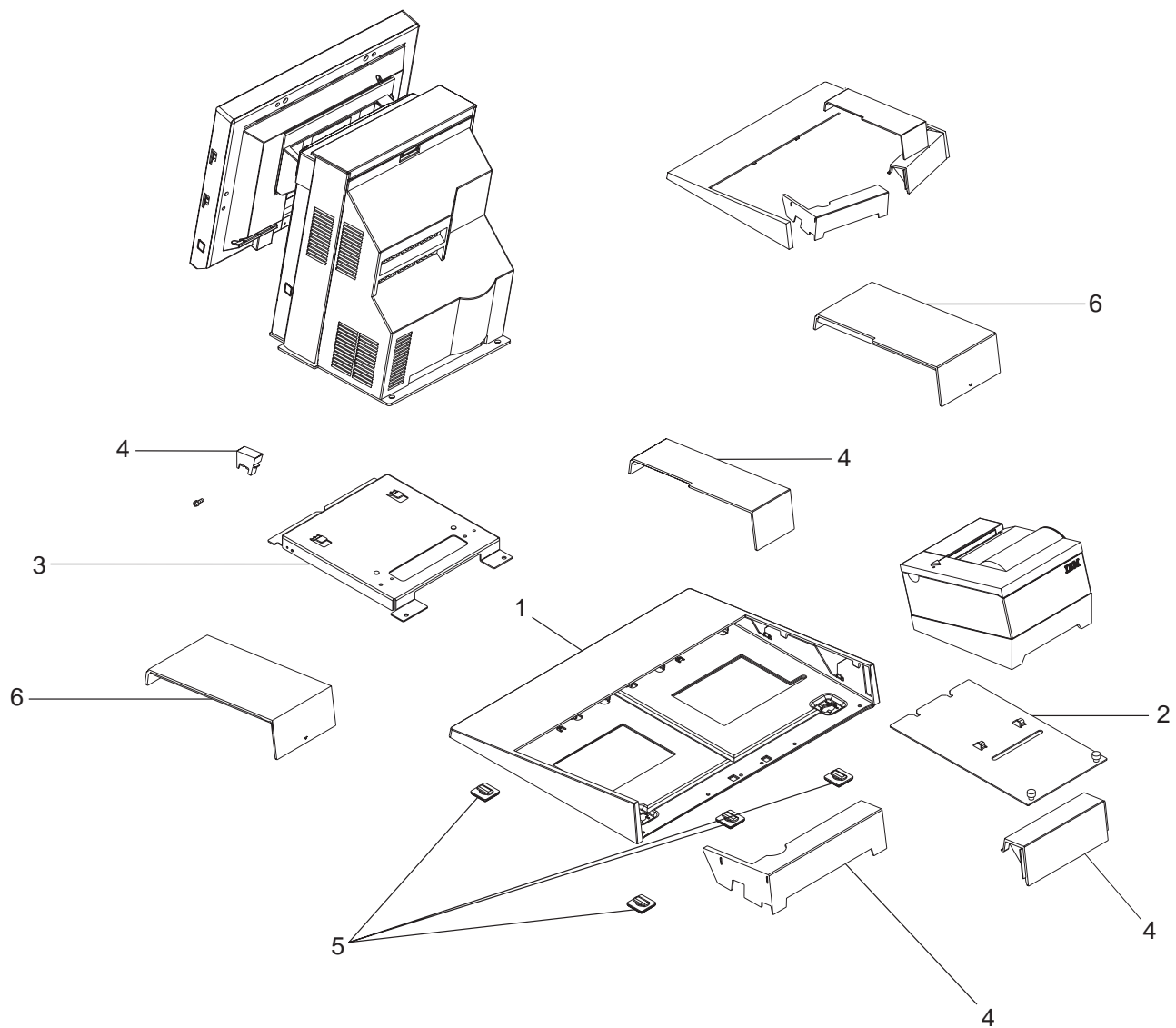

Asm- Index	Part Number	Units	Description
4-			Countertop non-keyboard integration tray and filler panels
-1	41D0261		Plate/fence assembly, counter top mounting
-2	41D0211		Plate assembly, printer mounting
-3	42V3966		Plate assembly, terminal mounting (includes screw)
-4	42V3967		Filler panel kit
-5			Feet, rubber (5), included in Hardware kit
-6	12X1129		Printer filler panel kit for non-keyboard trays
-	41D0212		Hardware, non-keyboard integration tray (kit - includes feet and screws, not illustrated)
-			
-			

Assembly 5: Cash drawer non-keyboard integration tray and filler panels

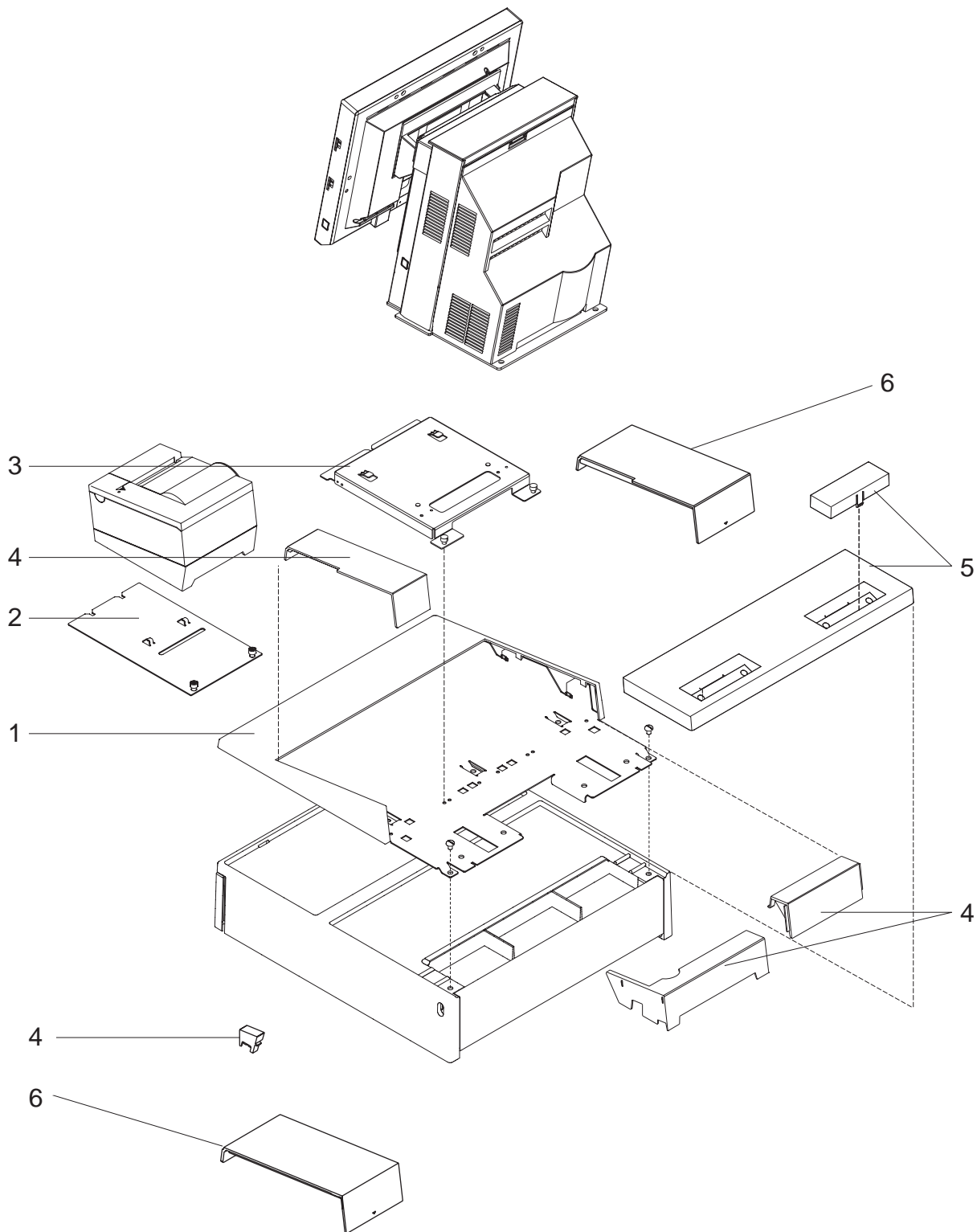

Asm- Index	Part Number	Units	Description
5-			Cash drawer non-keyboard integration tray and filler panels
-1	41D0210	1	Plate and fence, cash drawer mount
-2	41D0211	1	Plate, printer mounting
-3	42V3966	1	Plate, terminal mounting
-4	42V3967	1	Panels, filler
-5	20P0308	1	Cover, modesty (and 2 plugs)
-6	12X1129	1	Printer filler panel kit, non-keyboard
-	41P0212	1	Hardware, non-keyboard integration tray (kit - includes screws, not illustrated)
-			
-			

For power cords, see Appendix B, "Power cords," on page 113.

Appendix B. Power cords

Table 19. Power cord lengths and part numbers by country

Part number	Length	Country
39M5066	4.3 m	Argentina
39M5093	4.3 m	Bahamas, Barbados, Bermuda, Bolivia, Canada, Cayman Islands, Columbia, Costa Rica, Dominican Rep., El Salvador, Ecuador, Guatemala, Haiti, Honduras, Jamaica, Mexico, Netherlands Antilles, Nicaragua, Panama, Peru, Philippines, U.S., Venezuela
39M5100	4.3 m	Australia, New Zealand
39M5204	4.3 m	China (PR)
39M5211	4.3 m	Korea
39M5121	4.3 m	Europe
39M5128	4.3 m	Denmark
39M5142	4.3 m	South Africa
39M5149	4.3 m	United Kingdom, Hong Kong
39M5156	4.3 m	Switzerland
39M5163	4.3 m	Chile, Italy
39M5170	4.3 m	Israel
39M5191	4.3 m	Japan
39M5079	4.3 m (non-locking)	United States
39M5077	1.8 m	United States, Chicago
39M5107	4.3 m (locking)	United States

Appendix C. System specifications and planning information

Physical specifications and dimensions	115
Dimensions with trays	116
Dimensions of unit with 12-inch display	118
Dimensions of unit with 15-inch display	119
Dimensions of unit with 17-inch display	120
Power requirements and consumption	121
Power.	121
Port power ratings	121
Connector-pin assignments	122
External connectors.	122
Speaker connector	122
MSR connector	122
USB port connectors	124
Keyboard connector	124
Mouse connector	125
Microphone connector.	125
Headphone connector.	125
Serial connectors	125
Ethernet connector	127
External video connector.	128
Cash drawer connector (2)	129
Integrated customer display connector.	129
Temperature, humidity, and altitude limits	130

This appendix provides information on power subsystems, and environmental requirements.

Physical specifications and dimensions

The SurePOS 500 Series physical specifications are described in Table 20.

Table 20. Height, weight and depth of the SurePOS 500 Models 545 and 565

4846	Weight	Height: Tablet at 15 degrees	Height maximum	Depth: Tablet at 15 degrees	Depth: Tablet at 60 degrees	Width
Tower and 12-in. tablet	11.3 kg (25 lbs)	357.9 mm (14.0 in.)	374.1 mm (14.7 in.)	316.8 mm (12.5 in.)	385.8 mm (15.2 in.)	307.9 mm (12.12 in.)
Tower and 15-in. tablet	12.2 kg (27 lbs)	381.8 mm (15.0 in.)	393.6 mm (15.5 in.)	324.4 mm (12.8 in.)	405.8 mm (15.9 in.)	369 mm (14.5 in.)
Tower and 17-in. tablet	14.51 kg (32 lbs)	404.5 mm (15.93 in.)	414.6 mm (16.32 in.)	335.2 mm (13.2 in.)	423.9 mm (16.7 in.)	402.3 mm (15.83 in.)

Table 21. Weights of integrated, distributed displays and MSR

Component	Weight
Integrated 2x20 display	0.2 kg (0.38 lbs)
Distributed 2x20 display	0.5 kg (1.2 lbs)
Distributed APA display	0.7 kg (1.6 lbs)

Table 21. Weights of integrated, distributed displays and MSR (continued)

Component	Weight
MSR (three-track or JUCC)	0.16 kg (0.41 lbs)

Dimensions with trays

Table 22 provides the dimensions shown by measurements A and B in Figure 68, Figure 69 on page 117, and Figure 70 on page 117.

Note: The tablet is shown at 15 degrees.

Table 22. SurePOS 500 Models 545 and 565 dimensions. See Figure 68 and Figure 69 on page 117 to locate Measurement A and B

Product with 12 in. tablet and the following:	Measurement A	Measurement B
Counter top tray	382.4 mm (15.1 in.)	478.6 mm (18.8 in.)
Cash drawer tray	493.5 mm (19.4 in.)	480.9 mm (18.9 in.)
Retail tray	527.4 mm (20.8 in.)	489.2 mm (19.2 in.)
Product with 15 in. tablet and the following:		
Counter top tray	406.2 mm (15.9 in.)	509.2 mm (20.0 in.)
Cash drawer tray	517.3 mm (20.4 in.)	511.4 mm (20.1 in.)
Retail tray	551.1 mm (21.7 in.)	519.7 mm (20.5 in.)
Product with 17 in. tablet and the following:		
Counter top tray	428.9 mm (16.9 in.)	525.9 mm (20.7 in.)
Cash drawer	540 mm (21.3 in.)	528.1 mm (20.8 in.)
Retail tray	573.8 mm (22.6 in.)	536.4 mm (21.1 in.)

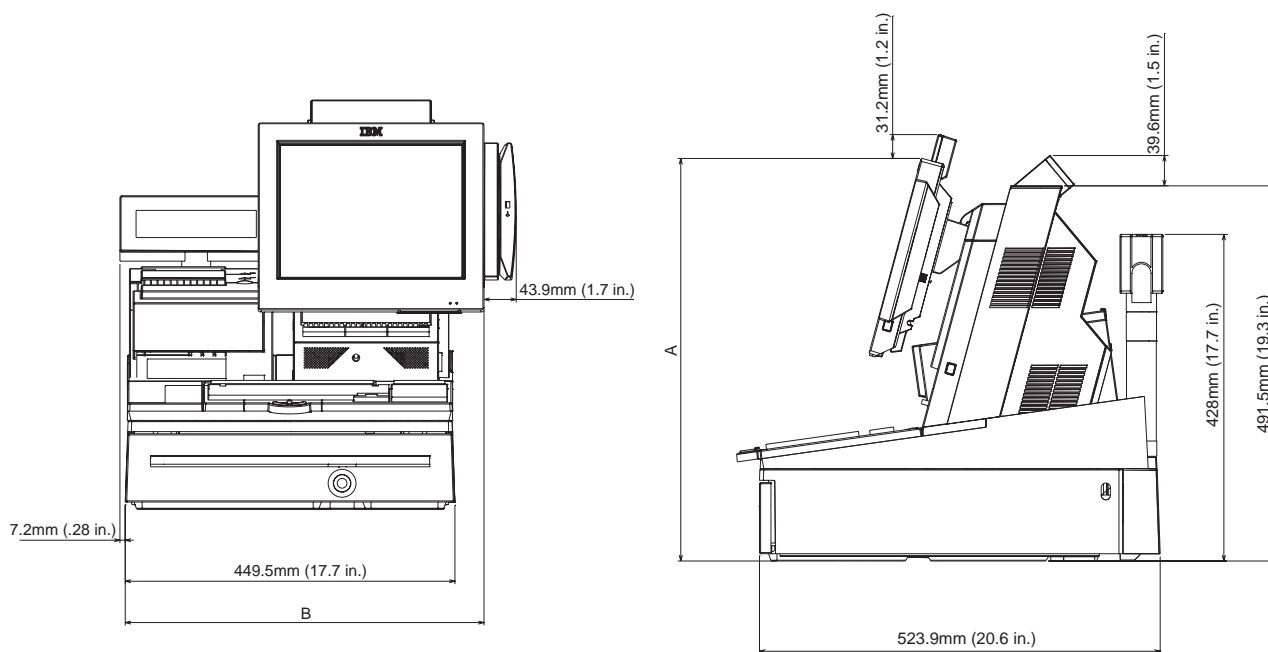

Figure 68. Dimensions of SurePOS Models 545 and 565 with retail tray. The tablet is shown at 15 degrees.

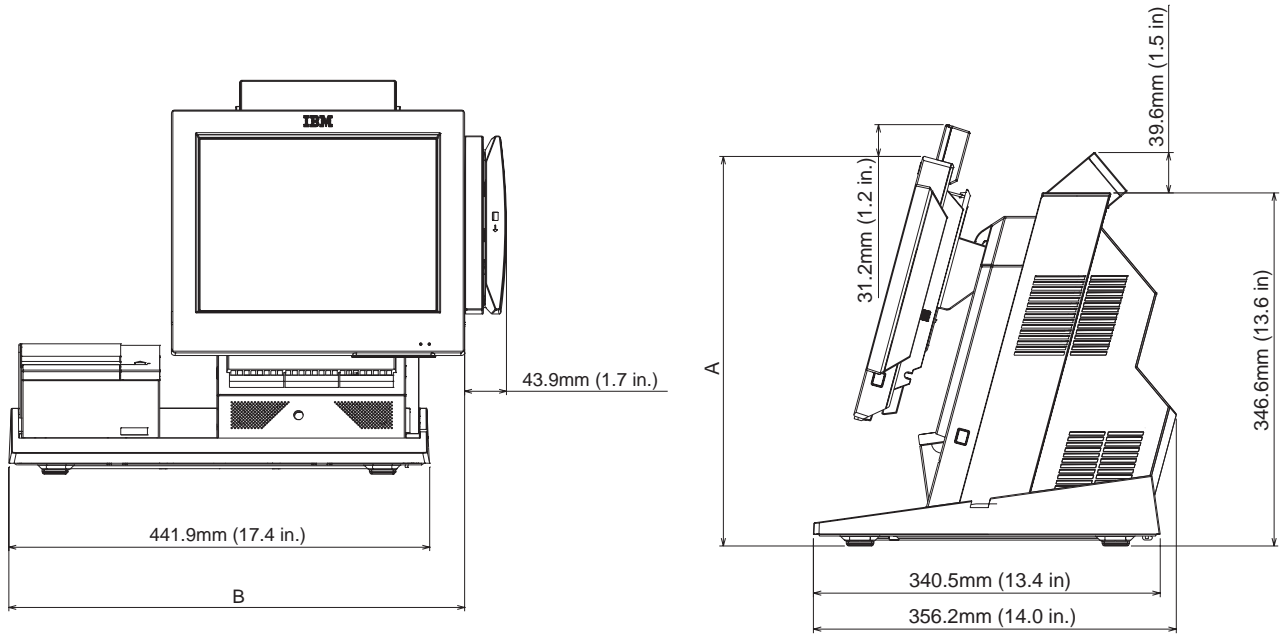

Figure 69. Dimensions of SurePOS Models 545 and 565 with counter top tray. The tablet is shown at 15 degrees.

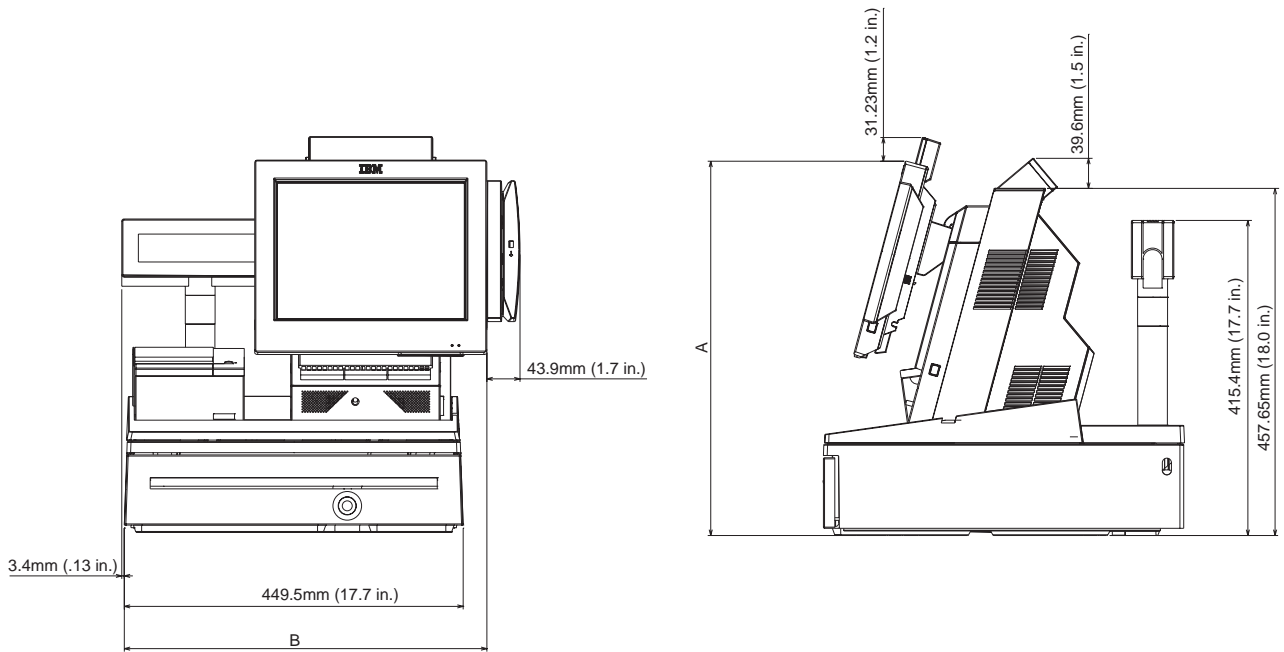

Figure 70. SurePOS Models 545 and 565 with cash drawer tray. The tablet is shown at 15 degrees.

Dimensions of unit with 12-inch display

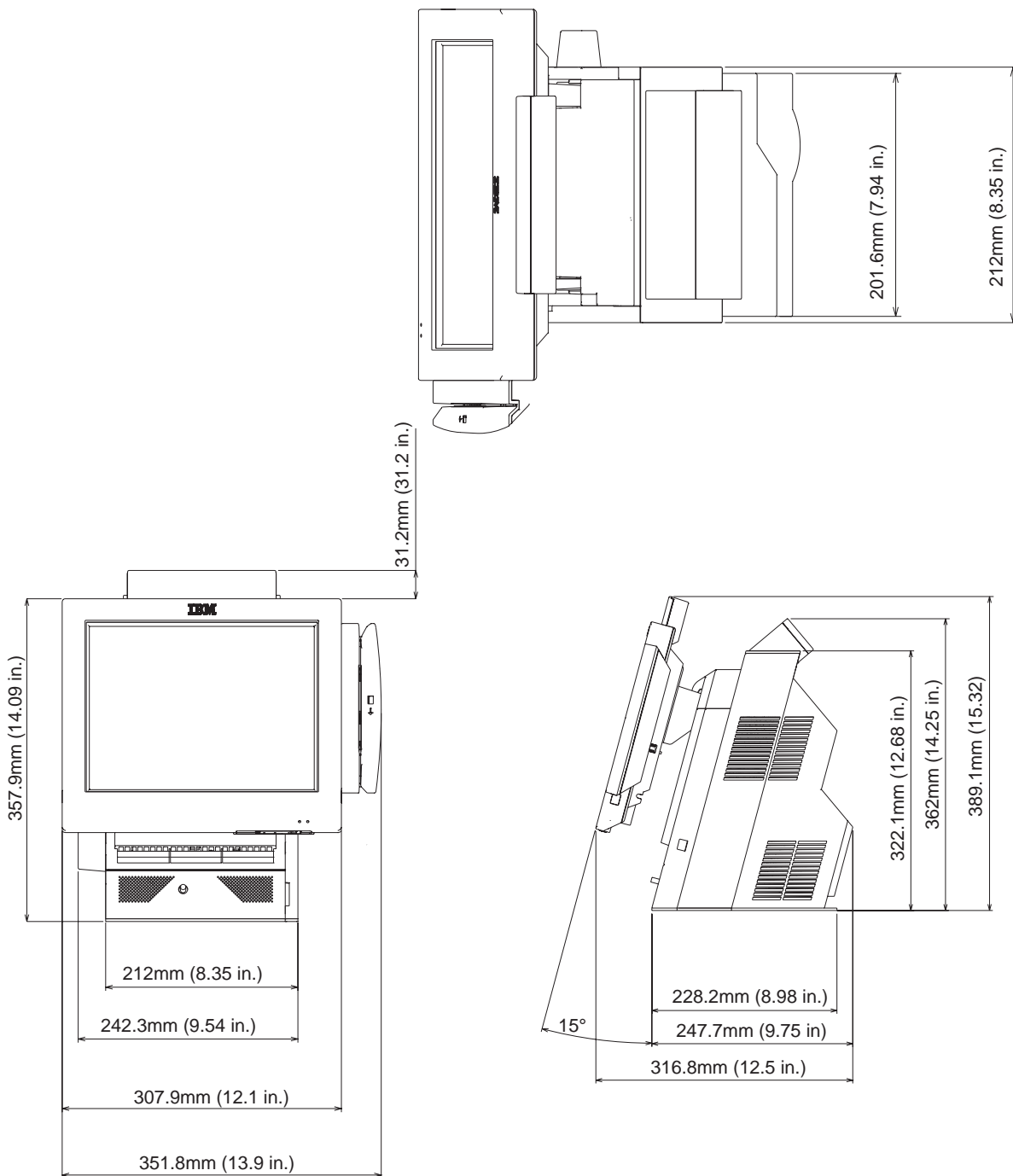

Figure 71. Dimensions of unit with 12-inch display

Dimensions of unit with 15-inch display

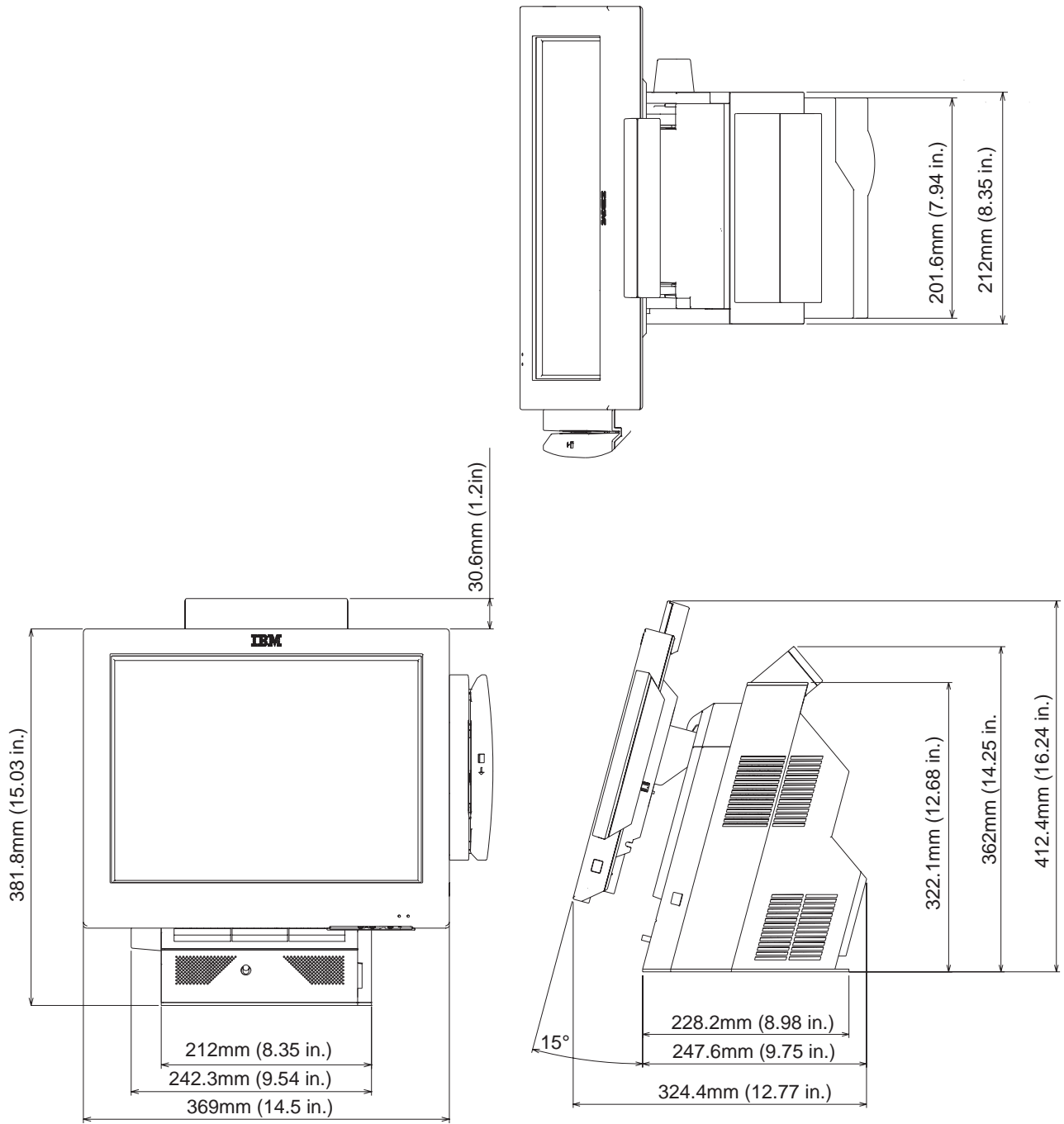
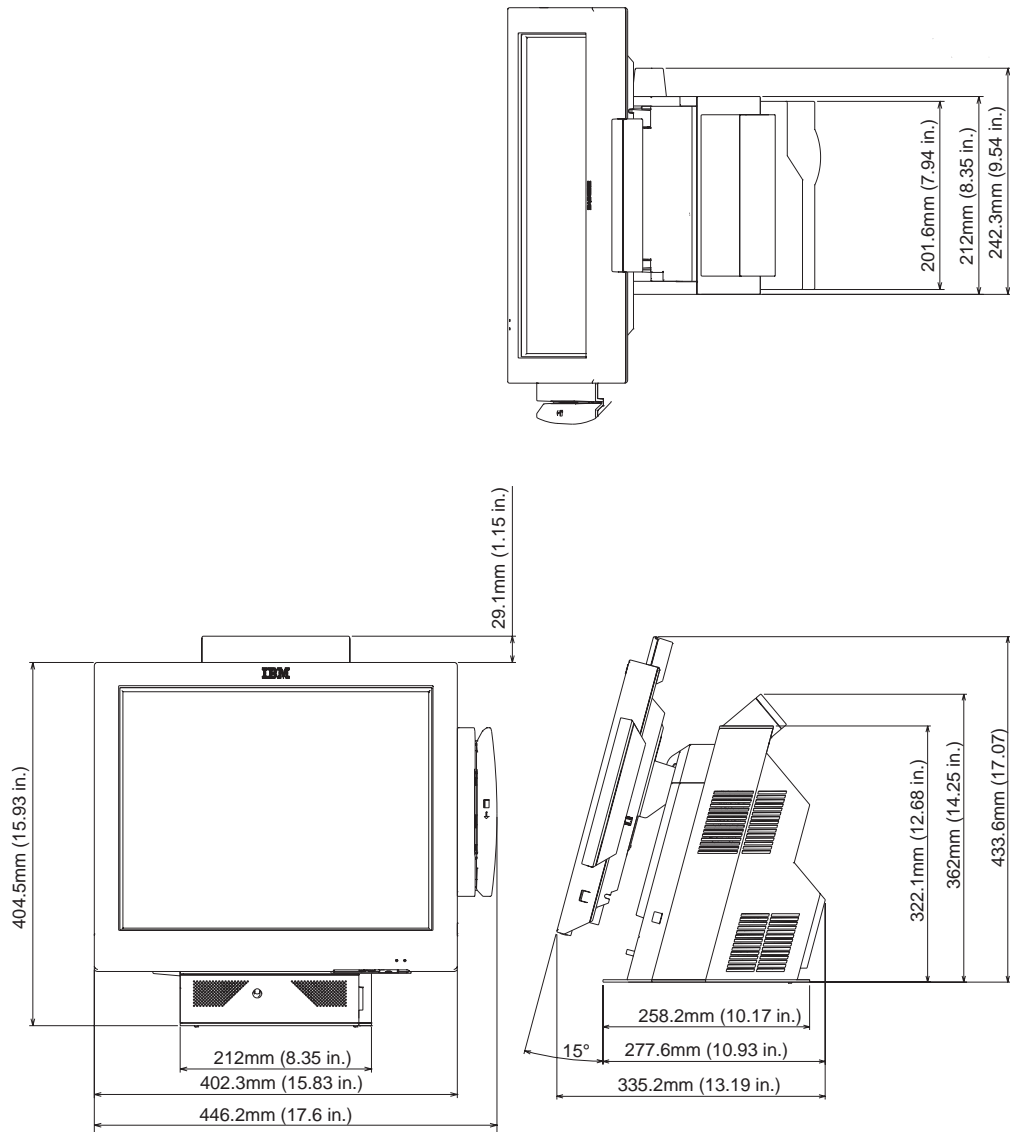

Figure 72. Dimensions of unit with 15-inch display

Dimensions of unit with 17-inch display



Power requirements and consumption

This section describes the power requirements and power consumption of the SurePOS 500 Series.

Power

Table 23. Input voltage, frequency

Input	Frequency
100 – 127 V AC	50 or 60 Hz
200 – 240 V AC	50 or 60 Hz

Table 24. SurePOS 500 Series Models 545 and 565 power supply

Nominal output voltage	Tolerance	Rated Current
+5.0 V AUX	±5%	2.0 A
+5.0 V MAIN	+5/-4%	8.0 A
+12.0 V	±5%	12.0 A
+3.3 V	±5%	6.0 A
-12.0 V	±10%	0.3 A
+25.3 V	±4%	3.0 A

Table 25. Power consumption

State:	Usage:
Off	4 W
Standby	80 W
Suspend	Not supported
On (idle, no I/O)	120 W
On (idle, I/O: cash drawer, MSR, 2/20, printer)	125 W
On (max, printing)	170 W
Input	100 - 127, 200 - 240 V AC (nominal), 50 or 60 Hz (+/- 3 Hz)
Voltage/Frequency	Sinusoidal, trapezoidal, or square wave inputs
Maximum kVA	0.3
AC Input	IEC 320 C14, unshielded right angle type
Connector/Cable leakage current	3.5 ma maximum
Inrush	< 30 A (peak, first cycle)

Port power ratings

- Only one cash drawer may be activated at any instance in time.
- Hot plugging of powered USB devices, especially printers, is not supported. Some powered USB devices create surge currents that may cause the system power supply to initiate over-current shut down.

Note: All ports provide protection against power surges.

Table 26. Port current ratings

Port/Name	Port Voltage Ratings	Maximum Current
Distributed VFD/Serial	5 V	0.95 A
	12 V	0.65 A
USB (x6)	5 V	0.5 A
USB Plus Power	5 V	0.5 A
	12 V	1.5 A
	24 V	3.0 A continuous 5.0 A peak
Keyboard and Mouse	5 V	0.6 A
3A, 3B/cash drawer	24 V	1 A for 200 msec

Connector-pin assignments

This following sections list the connector-pin assignments for the external and internal connectors.

External connectors

The following sections show the connector-pin assignments for external connectors.

Speaker connector

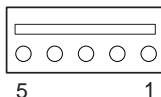

Table 27. Speaker connector-pin assignments

Pin	Connect
1	+12 V AC
2	Ground
3	Line Left
4	Line Right
5	Ground

MSR connector

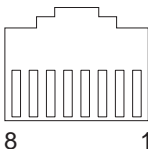

Table 28. MSR connector-pin assignments

Pin	Connector
1	+5 V dc
2	Serial data out
3	Serial data in

Table 28. MSR connector-pin assignments (continued)

Pin	Connector
4	Ground
5	KBD enable
6	Keyboard data
7	Keyboard clock
8	Ground

USB port connectors

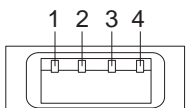

Table 29. USB port connector-pin assignments

Unpowered USB	
Pin	Connector
1	5 V bus
2	-Data
3	+Data
4	Ground

Note: Tablet USB ports are USB 1.1 compliant; side and back USB ports are USB 2.0 compliant.

Table 30. USB port connector-pin assignments

Powered USB	
Pin	Connector
Shell	Shield
1	5 V Vbus
2	-Data
3	+Data
4	Ground
5	Ground
6	Vplus (12 V or 24 V)
7	Vplus (12 V or 24 V)
8	Ground

Keyboard connector

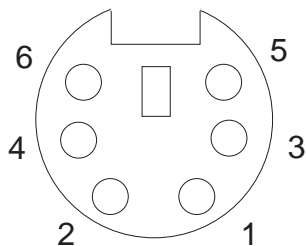

Table 31. Keyboard and mouse connector-pin assignments

Pin	Signal	I/O	Pin	Signal	I/O
1	Keyboard data	I/O	4	+5 V Main	I/O
3	Ground		5	Keyboard clock	

Mouse connector

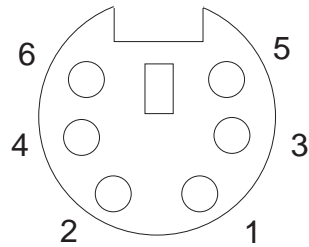

Table 32. Keyboard and mouse connector-pin assignments

Pin	Signal	I/O	Pin	Signal	I/O
2	Mouse data	I/O	4	+5 V Main	I/O
3	Ground		6	Mouse clock	

Microphone connector

The microphone connector is on the tower, at the lower left, below the side connector panel.

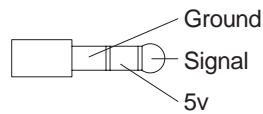

Table 33. Microphone connector-pin assignments

Pin	Signal
Tip	Signal
Ring	+5 V dc
Base	Ground

Headphone connector

The headphone connector is on the tower, at the lower left, below the side connector panel, with the microphone connector.

Table 34. Headphone connector-pin assignments

Pin	Signal
Tip	Left channel audio
Ring	Right channel audio
Base	Ground

Serial connectors

RJ-45 Connectors (3):

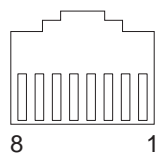

Table 35. RJ-45 connector-pin assignments

Pin	Signal	Pin	Signal
1	DSR	5	RXD
2	CD	6	TXD
3	DTR	7	CTS
4	Ground	8	RTS

15-pin serial connector: The 15-pin serial connector is a female connector.

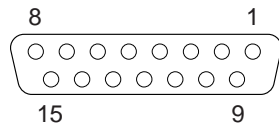

Table 36. Assignments for 15-pin serial connector

Pin	Connector	Pin	Connector
1	Carrier detect	8, 9	+12 V dc at 0.5 A maximum
2	Receive data	11	Distributed display present
3	Transmit data	12	Data set ready
4	Data terminal ready	13	Request to send
5	Ground	14	Clear to send
6	Ground	15	Ring indicate
7, 10	+5 V dc at 0.5 A maximum		

Ethernet connector

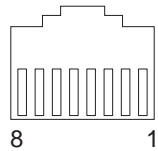

Table 37. Ethernet connector-pin assignments

Pin	Signal	I/O	Pin	Signal	I/O
1	TxD+	O	5	Ground	
2	TxD-	O	6	RxD-	I
3	RxD+	I	7	Ground	
4	Ground		8	Ground	

External video connector

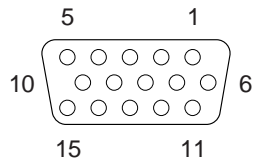

Table 38. Assignment of external-video connector pins

Pin	Connector	Pin	Connector
1	Red	9	No connection
2	Green	10	Ground
3	Blue	11	No connection
4	No connection	12	Monitor ID1
5	Ground	13	Horizontal sync
6	Red ground	14	Vertical sync
7	Green ground	15	Monitor ID3
8	Blue ground		

Cash drawer connector (2)

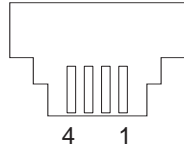

Table 39. Assignment of cash drawer connector pins

Pin	Connector
1	Ground
2	Sensor
3	Open signal
4	+24 V dc

Integrated customer display connector

To access this connector, you must remove the rear cover.

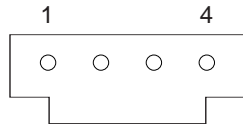

Table 40. Assignment of integrated customer-display connector pins

Pin	Connector
1	+5 V dc at 0.5 A maximum
2	Transmit data
3	Integrated customer display present
4	Ground

Temperature, humidity, and altitude limits

Table 41. Temperature, humidity, altitude limits

Condition	Temperature limits (dry bulb)	Relative Humidity	Maximum wet bulb temperature
Operating	5 to 40° C.	8 to 80 %	27° C.
Power Off	0 to 52° C.	5 to 95 %	27° C.
Storage	0 to 60° C.	5 to 100%	29° C.

This product is designed to operate up to 3050 m (10,000 ft.).

Appendix D. Notices

This information was developed for products and services offered in the U.S.A.

IBM may not offer the products, services, or features discussed in this document in other countries. Consult your local IBM representative for information on the products and services currently available in your area. Any reference to an IBM product, program, or service is not intended to state or imply that only that IBM product, program, or service may be used. Any functionally equivalent product, program, or service that does not infringe any IBM intellectual property right may be used instead. However, it is the user's responsibility to evaluate and verify the operation of any non-IBM product, program, or service.

IBM may have patents or pending patent applications covering the subject matter in this document. The furnishing of this document does not give you any license to these patents. You can send license inquiries, in writing, to:

IBM Director of Licensing
IBM Corporation
North Castle Drive
Armonk, NY 10504-1785
U.S.A.

For license inquiries regarding double-byte (DBCS) information, contact the IBM Intellectual Property Department in your country or send inquiries, in writing, to:

IBM World Trade Asia Corporation
Licensing
2-31 Roppongi 3-chome, Minato-ku
Tokyo 106, Japan

The following paragraph does not apply to the United Kingdom or any other country where such provisions are inconsistent with local law: INTERNATIONAL BUSINESS MACHINES CORPORATION PROVIDES THIS PUBLICATION "AS IS" WITHOUT WARRANTY OF ANY KIND, EITHER EXPRESS OR IMPLIED, INCLUDING, BUT NOT LIMITED TO, THE IMPLIED WARRANTIES OF NON-INFRINGEMENT, MERCHANTABILITY, OR FITNESS FOR A PARTICULAR PURPOSE. Some states do not allow disclaimer of express or implied warranties in certain transactions, therefore, this statement may not apply to you.

This information could include technical inaccuracies or typographical errors. Changes are periodically made to the information herein; these changes will be incorporated in new editions of the publication. IBM may make improvements and/or changes in the product(s) and/or program(s) described in this publication at any time without notice.

IBM may use or distribute any of the information you supply in any way it believes appropriate without incurring any obligation to you.

Any references in this information to non-IBM Web sites are provided for convenience only and do not in any manner serve as an endorsement of those Web sites. The materials at those Web sites are not part of the materials for this IBM product and use of those Web sites is at your own risk.

Information concerning non-IBM products was obtained from the suppliers of those products, their published announcements or other publicly available sources. IBM

has not tested those products and cannot confirm the accuracy of performance, compatibility or any other claims related to non-IBM products. Questions on the capabilities of non-IBM products should be addressed to the suppliers of those products.

This information is for planning purposes only. The information herein is subject to change before the products described become available.

Electronic emission notices

Federal Communications Commission (FCC) Statement

This equipment has been tested and found to comply with the limits for a Class A digital device, pursuant to Part 15 of the FCC Rules. These limits are designed to provide reasonable protection against harmful interference when the equipment is operated in a commercial environment. This equipment generates, uses, and can radiate radio frequency energy and, if not installed and used in accordance with the instruction manual, may cause harmful interference to radio communications. Operation of this equipment in a residential area is likely to cause harmful interference, in which case the user will be required to correct the interference at his own expense.

Properly shielded and grounded cables and connectors must be used in order to meet FCC emission limits. IBM is not responsible for any radio or television interference caused by using other than recommended cables and connectors or by unauthorized changes or modifications to this equipment. Unauthorized changes or modifications could void the user's authority to operate the equipment.

This device complies with part 15 of the FCC Rules. Operation is subject to the following two conditions: (1) this device may not cause harmful interference, and (2) this device must accept any interference received, including interference that may cause undesired operation.

Industry Canada Class A Emission Compliance Statement

This Class A digital apparatus complies with Canadian ICES-003.

Avis de conformité aux normes d'Industrie Canada

Cet appareil numérique de la classe A est conforme à la norme NMB-003 du Canada.

European Union (EU) Mark of Conformity Statement

This product has been tested and found to comply with the limits for Class A Information Technology Equipment according to European Standard EN 55022. The limits for Class A equipment were derived for commercial and industrial environments to provide reasonable protection against interference with licensed communication equipment.

Warning: This is a Class A product. In a domestic environment this product may cause radio interference in which case the user may be required to take adequate measures.

Properly shielded and grounded cables and connectors must be used in order to reduce the potential for causing interference to radio and TV communications and to other electrical or electronic equipment. Such cables and connectors are available from IBM authorized dealers. IBM cannot accept responsibility for any interference caused by using other than recommended cables and connectors.

Germany

Zulassungsbescheinigung laut dem Deutschen Gesetz über die elektromagnetische Verträglichkeit von Geräten (EMVG) vom 30. August 1995 (bzw. der EMC EG Richtlinie 89/336).

Dieses Gerät ist berechtigt in Übereinstimmung mit dem Deutschen EMVG das EG-Konformitätszeichen - CE - zu führen.

Verantwortlich für die Konformitätserklärung nach Paragraph 5 des EMVG ist die IBM Deutschland Informationssysteme GmbH, 70548 Stuttgart.

Informationen in Hinsicht EMVG Paragraph 3 Abs. (2) 2:

Das Gerät erfüllt die Schutzanforderungen nach EN 50082-1 und EN 55022 Klasse A.
--

EN 55022 Klasse A Geräte müssen mit folgendem Warnhinweis versehen werden:

"Warnung: dies ist eine Einrichtung der Klasse A. Diese Einrichtung kann im Wohnbereich Funkstörungen verursachen; in diesem Fall kann vom Betreiber verlangt werden, angemessene Maßnahmen durchzuführen und dafür aufzukommen."

EN 50082-1 Hinweis:

"Wird dieses Gerät in einer industriellen Umgebung betrieben (wie in EN 50082-2 festgelegt), dann kann es dabei eventuell gestört werden. In solch einem Fall ist der Abstand bzw. die Abschirmung zu der industriellen Störquelle zu vergrößern."

Anmerkung:

Um die Einhaltung des EMVG sicherzustellen sind die Geräte, wie in den IBM Handbüchern angegeben, zu installieren und zu betreiben.

Australia / New Zealand

Attention: This is a Class A product. In a domestic environment this product may cause radio interference, in which case the user may be required to take adequate measures.

Japanese power line harmonics compliance statement

高調波ガイドライン適合品

高調波ガイドライン適合品

Japanese Voluntary Control Council for Interference (VCCI) Statement

This product is a Class A Information Technology Equipment and conforms to the standards set by the Voluntary Control Council for Interference by Technology Equipment (VCCI). In a domestic environment this product may cause radio interference in which case the user may be required to take adequate measures.

この装置は、情報処理装置等電波障害自主規制協議会（VCCI）の基準に基づくクラスA情報技術装置です。この装置を家庭環境で使用すると電波妨害を引き起こすことがあります。この場合には使用者が適切な対策を講ずるよう要求されることがあります。

Korean Communications Statement

Please note that this device has been approved for business purposes with regard to electromagnetic interference. If you find this is not suitable for your use, you may exchange it for a non-business purpose one.

A급 기기(업무용)

이 기기는 업무용으로 전자파적합등록을 받은 기기이오니 판매자 또는 이용자는 이점을 주의하시기 바라며, 만약 구입하였을 때에는 구입한 곳에서 가정용으로 교환하시기 바랍니다.

Chinese Class A warning statement

Attention: This is a Class A product. In a domestic environment this product may cause radio interference in which case the user may be required to take adequate measures.

中华人民共和国“A类”警告声明

声 明

此为 A 级产品，在生活环境中，该产品可能会造成无线电干扰。在这种情况下，可能需要用户对其干扰采取切实可行的措施。

Taiwanese Class A warning statement

警告使用者：
這是甲類的資訊產品，在居住的環境中使用時，可能會造成射頻干擾，在這種情況下，使用者會被要求採取某些適當的對策。

Taiwan contact information

台灣IBM 產品服務聯絡方式：
台灣國際商業機器股份有限公司
台北市松仁路7號3樓
電話：0800-016-888

IBM Taiwan Product Service Contact Info:
IBM Taiwan Corporation
3F, No 7, Song Ren Road, Taipei Taiwan
Telephone: 0800-016-888

Note: Cable ferrites are required to suppress radiated EMI emissions and shall not be removed.

Taiwan recycle statement

Waste batteries, please recycle.



Electrostatic Discharge (ESD)

Attention: ESD damage can occur when there is a difference in charge between the part, the product, and the service person. No damage will occur if the service person and the part being installed are at the same charge level.

ESD Damage Prevention

Anytime a service action involves physical contact with logic cards, modules, back-panel pins, or other ESD sensitive (ESDS) parts, the service person must be connected to an ESD common ground point on the product through the ESD wrist strap and cord.

The ESD ground clip can be attached to any frame ground, ground braid, green wire ground, or the round ground prong on the AC power plug. Coax or connector outside shells can also be used.

Handling Removed Cards

Logic cards removed from a product should be placed in ESD protective containers. No other object should be allowed inside the ESD container with the logic card. Attach tags or reports that must accompany the card to the outside of the container.

Trademarks

The following are trademarks of International Business Machines Corporation in the United States or other countries, or both:

IBM
the IBM logo
PS/2
SureMark

SurePoint
SurePOS
Wake on LAN

Microsoft, Windows, Windows NT, and the Windows logo are trademarks of Microsoft Corporation in the United States, other countries, or both.

Celeron and Intel are trademarks of Intel corporation in the United States, or other countries.

Java and all Java-based trademarks and logos are trademarks or registered trademarks of Sun Microsystems, Inc. in the United States, or other countries, or both.

Other company, product, or service names may be trademarks or service marks of others.

Appendix E. Safety information

Before you begin to install or service this product, read the following safety information.

Safety Information-English



To avoid a shock hazard, do not connect or disconnect any cables or perform installation, maintenance, or reconfiguration of this product during an electrical storm.



To avoid shock hazard:

- The power cord must be connected to a properly wired and earthed receptacle.
- Any equipment to which this product will be attached must also be connected to properly wired receptacles.



When possible, use one hand to connect or disconnect signal cables to prevent a possible shock from touching two surfaces with different electrical potentials.



DANGER: Electrical current from power, telephone, and communications cables is hazardous. To avoid shock hazard, connect and disconnect cables as shown below when installing, moving, or opening the covers of this product or attached devices.

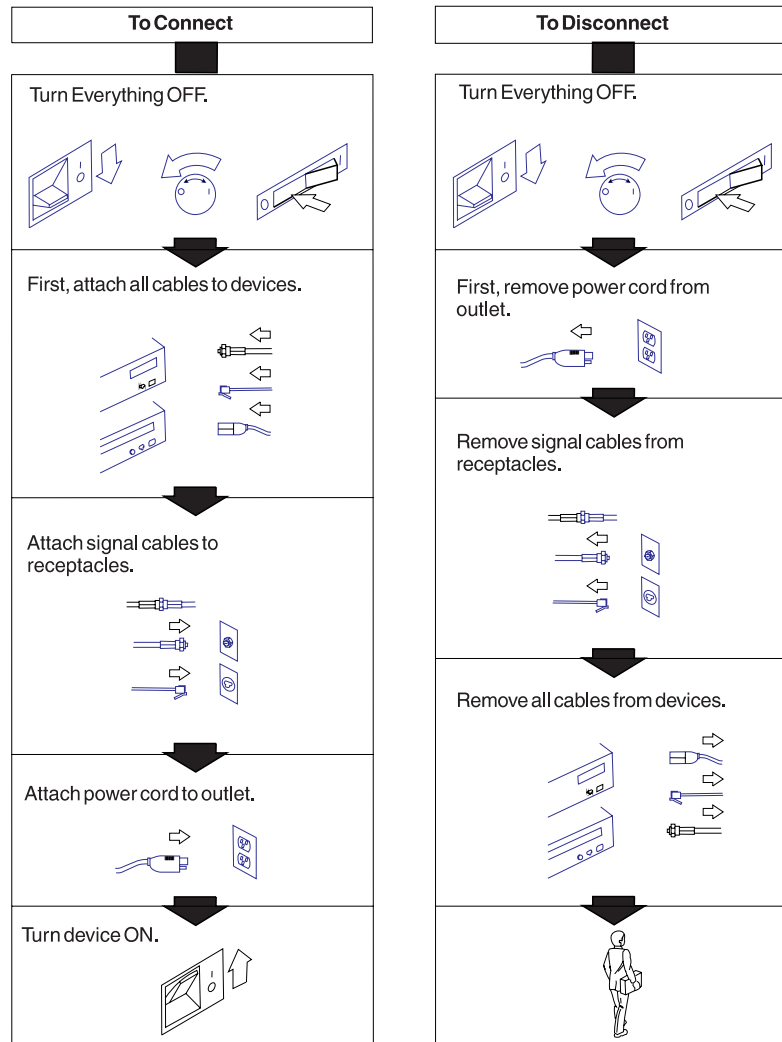

Note: In the UK, by law, the telephone cable must be connected after the power cord.

Note: In the UK, by law, the power cord must be disconnected after the telephone line cable.

Caution:

A lithium battery can cause a fire, an explosion, or a severe burn. Do not recharge, disassemble, heat above 100 degree C (212 degree F), solder directly to the cell, incinerate, or expose the cell contents to water.

Keep away from children.

Replace only with the part number specified for this IBM product. Use of a different battery may present a risk of fire or explosion. The battery connector is polarized; do not attempt to reverse the polarity.

Dispose of the battery according to local regulations.

Safety Information-Arabic

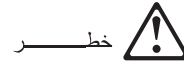

لتجنب خطورة الصدمات الكهربائية، لا يجب فصل أو توصيل أي كابلات أو القيام بأعمال تركيبات أو صيانة أو إعادة تنظيم أي من الأجهزة الكهربائية أثناء سريان التيار الكهربائي.

لتجنب خطورة الصدمات الكهربائية:

♦ لا بد من توصيل السلك الكهربائي لمصدر جيد التوصيل بالأرض ومجهز بطريقة صحيحة .

♦ وأي جهاز مصاحب لهذا المنتج يجب توصيله بمصدر مجهز بطريقة صحيحة .

وإن أمكن يجب استخدام يد واحدة في توصيل أو فصل كابلات الاشارات (التحكم) لتفادي أي صدمة محتملة نتيجة تلامس سطحيين بجهد كهربائي مختلف .

التيار الكهربائي النابع من كابلات الكهرباء أو التليفون تمثل خطورة ولتجنب مخاطر الصدمات الكهربائية، يجب اتباع التعليمات الخاصة بتوصيل الأسلاك كما هو موضح أدناه عند تركيب أو نقل أو فتح أغشية هذا المنتج أو الأجهزة المصاحبة له .

للتوصيل	للفصل
♦ يجب إيقاف الأجهزة (ظهور علامات سخونة للمقيس) يجب قراءة دليل الاستخدام للحصول على أي معلومات إضافية.	♦ يجب إيقاف الأجهزة . (يجب قراءة دليل الاستخدام للحصول على أي معلومات إضافية).
♦ أو لا يجب توصيل كل الأسلاك للأجهزة .	♦ قم برفع أسلاك الكهرباء من المخارج .
♦ يجب توصيل أسلاك الاشارة للمصادر الكهربائية	♦ قم برفع أسلاك الاشارة من المصادر الكهربائية.
♦ قم بتوصيل سلك الكهرباء للمخرج الخاص بالجهاز .	♦ قم برفع كافة الأسلاك من الأجهزة .
♦ قم بتشغيل الجهاز .	

تحذير :

يمكن أن تتسبب البطارية الليثيم في حريق أو انفجار أو حريق شديد

لا تقم بإعادة شحن البطارية أو تفكيكها أو تسخينها أعلى من 100 درجة مئوية (212 درجة فهرنهايت)، أو لحامها مباشرة بخلية البطارية أو تعريض محتويات خلية البطارية للمياه

تحفظ بعيدا عن متناول الاطفال

تستبدل فقط برقم الجزء المحدد لهذا المنتج من شركة IBM

قد ينتج عن استعمال نوع مختلف من البطارية المخاطرة بحدوث حريق أو انفجار

لوصلة البطارية قطبية محددة، لا تحاول عكس هذه القطبية تخلص من البطارية طبقا للقانون المحلي

Safety Information-Brazilian Portuguese



Para evitar choque elétrico, não conecte ou desconecte qualquer cabo ou faça instalação, manutenção, ou reconfiguração deste produto quando houver relâmpagos.



Para evitar risco de choque:

- O cabo de força tem que estar conectado a uma tomada com fios adequados e corretamente aterrada.
- Qualquer equipamento, ao qual este produto será acoplado, também deverá estar conectado a tomadas com fios adequados.



Sempre que possível, utilize apenas uma das mãos para ligar ou desligar os cabos de sinal, a fim de evitar possíveis choques elétricos por tocar em duas superfícies com potenciais diferentes.



PERIGO:

A corrente elétrica dos cabos de força, telefônicos, e de comunicação é perigosa. Para evitar risco de choque elétrico, ligue e desligue os cabos, como mostrado abaixo ao instalar, mover, ou abrir as tampas deste produto ou dos dispositivos acoplados.

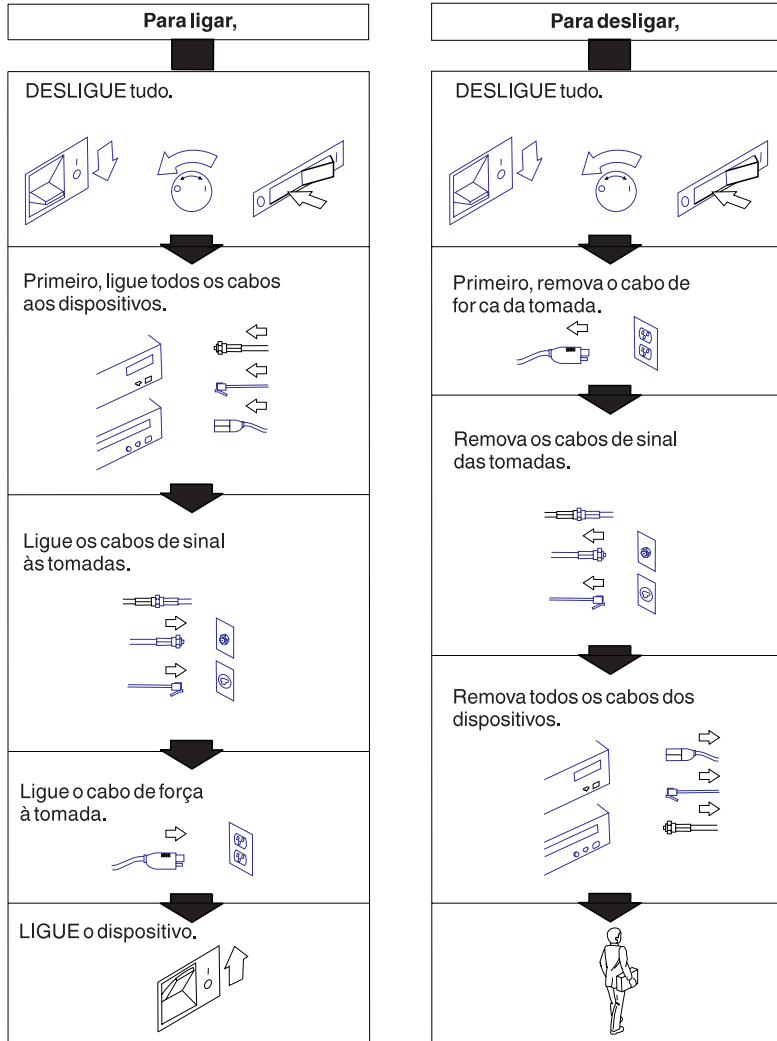

Cuidado:

Uma bateria de lítio pode causar incêndio, explosão ou queimaduras graves. Não recarregue, desmonte ou aqueça acima de 100°C (212°F), não utilize solda diretamente na célula, nem incinere ou exponha o conteúdo da célula à água.

Mantenha longe do alcance de crianças.

Substitua apenas pelo número de peça especificado para este produto IBM. A utilização de uma bateria diferente representa risco de incêndio ou explosão. O conector da bateria é polarizado; não tente reverter a polaridade.

Descarte a bateria de acordo com as regulamentações locais.

Safety Information-French



Pour éviter tout risque de choc électrique, ne manipulez aucun câble et n'effectuez aucune opération d'installation, d'entretien ou de reconfiguration de ce produit au cours d'un orage.



Pour éviter tout risque de choc électrique:

- Le cordon d'alimentation doit être branché sur une prise d'alimentation correctement câblée et mise à la terre.
- D'autre part, tout le matériel connecté à ce produit doit également être branché sur des prises d'alimentation correctement câblées et mises à la terre.



Afin d'éviter tout risque de choc électrique provenant d'une différence de potentiel de terre, n'utilisez qu'une main, lorsque cela est possible, pour connecter ou déconnecter les cordons d'interface.



DANGER:

Le courant électrique provenant des câbles d'alimentation, téléphoniques et de transmission peut présenter un danger. Pour éviter tout risque de choc électrique, connectez et déconnectez ces câbles comme indiqué ci-dessous lorsque vous installez ou déplacez ce matériel ou les unités connectées, ou que vous soulevez un carter.

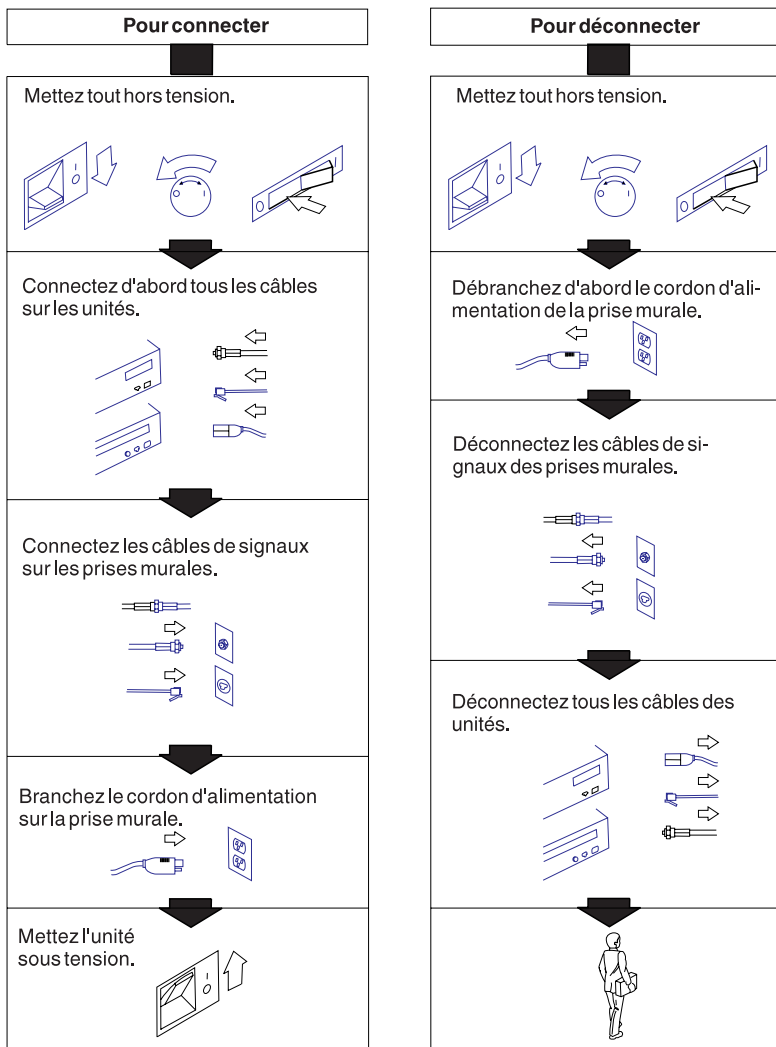

Attention:

Prenez garde aux risques d'incendie, d'explosion ou de brûlures graves liés à l'utilisation d'une pile au lithium. Ne la rechargez pas et ne la démontez pas. Ne l'exposez pas à une température supérieure à 100 °C, ne la soudez pas, ne la faites pas brûler et n'en exposez pas le contenu à l'eau.

Gardez la pile hors de portée des enfants.

Si vous la remplacez, commandez une pile de rechange de e. même référence. Toute autre pile risquerait de prendre feu ou d'exploser. Le connecteur de la pile est polarisé. N'essayez pas d'inverser la polarité.

Pour le recyclage ou la mise au rebut, reportez-vous à la réglementation en vigueur.

Safety Information-Hebrew



כדי להימנע ממכת חשמל, אסור לחבר או לנתק כל כבל או לבצע התקנה, תחזוקה או הגדרה מחדש של מוצר זה במהלך סופת ברקים.



כדי להימנע מסכנת מכת חשמל:

- כבל המתח חייב להיות מחובר לשקע מחוטט ומוארק כראוי.
- כל ציוד שאליו מוצר זה יחובר, חייב גם הוא להיות מחובר לשקעים מחוטטים כראוי.



כאשר ניתן, השתמשו ביד אחת על מנת לחבר או לנתק את כבלי האותות, כדי למנוע מכת חשמל אפשרית כתוצאה מוניהה בשני משטחים בעלי פוטנציאל חשמלי שונה.

סכנה: זרם חשמלי ממקור מתח, מלפון וכבלי תקשורת הוא מסוכן. כדי להימנע מסכנת מכת חשמל, יש לחבר ולנתק את הכבלים כפי שמודגם להלן, כאשר מתקינים, מעבירים או פותחים את המכסה של מוצר זה או של מכשירים מצורפים.

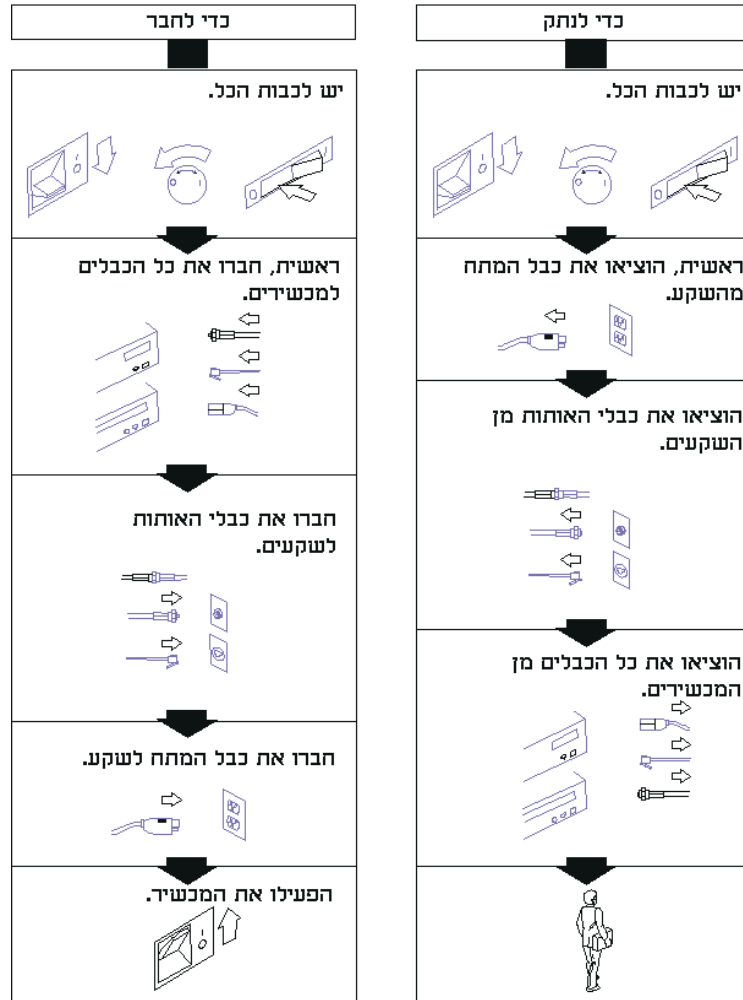

הערה: בבדיקה, על פי חוק, יש לחבר את כבל הטלפון אחרי כבל המתח.

הערה: בבדיקה, על פי חוק, יש לנתק את כבל המתח אחרי כבל הטלפון.

זהירות:

סוללת ליתיום עלולה לגרום לשריפה, לפיצוץ או לכוויה קשה.

אין לטעון אותה מחדש, לחממה מעל 100 מעלות צלזיוס (212 מעלות פרנהייט), להלחים ישירות לתא הסוללה, לשרוף אותה או לחשוף את תוכן התא למים.

יש להרחיק מילדים.

יש להחליף רק עם מספר החלק שצויין עבור מוצר יבמ זה.

השימוש בסוללה אחרת עלול לגרום לסכנת אש או פיצוץ.

המחבר של הסוללה הוא מקוטב; אין לנסות ולשנות את הקיטוב. יש לסלק את הסוללה על פי הנוהלים המקומיים.

Safety Information-Korean



위험

감전 쇼크의 위험을 피하기 위하여 천동번개가 치는 동안에는 전원을 연결하거나 또는 끊지 마시고 또한 본 제품의 설치, 수리 및 시스템 재구성을 하지 마시오.



위험

감전 쇼크의 위험을 피하기 위하여:

- 전원은 반드시 적정 규격의 전선을 사용하시고 접지선이 연결된 접속기와 연결 하십시오.
- 본 제품과 연결되는 모든 기기는 반드시 적정 규격의 전선으로 접지선이 연결된 접속기와 연결되어 있어야 합니다.



위험 통지 사항

위험

신호케이블을 연결하거나 단절할 때는 가능하면 한 손만을 사용하십시오. 전위나 다른 두 표면을 동시에 만지면 전기적 충격을 받을 수 있기 때문입니다.

 **위험:** 전원, 전화 및 통신 케이블에 흐르는 전류는 위험합니다. 전기 쇼크를 방지하려면 이 제품이나 부속장치를 설치, 이동하거나 덮개를 열때 아래에 표시된 대로 케이블을 연결하거나 단절하십시오.

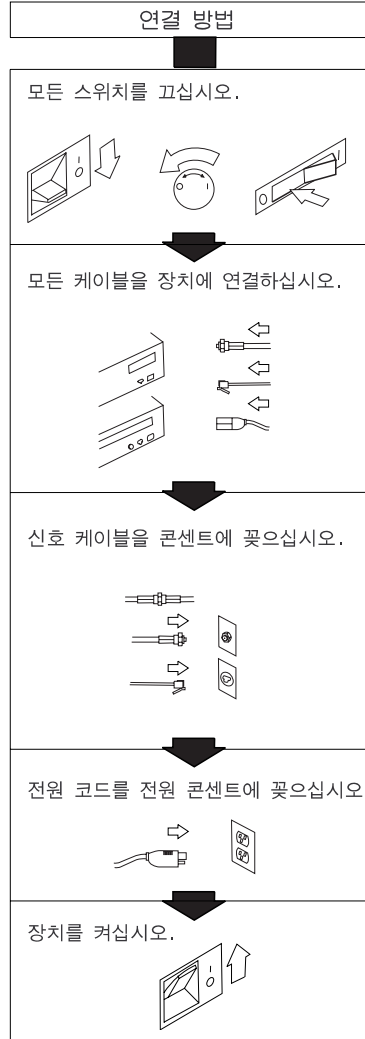

Note: In the UK, by law, the telephone cable must be connected after the power cord.

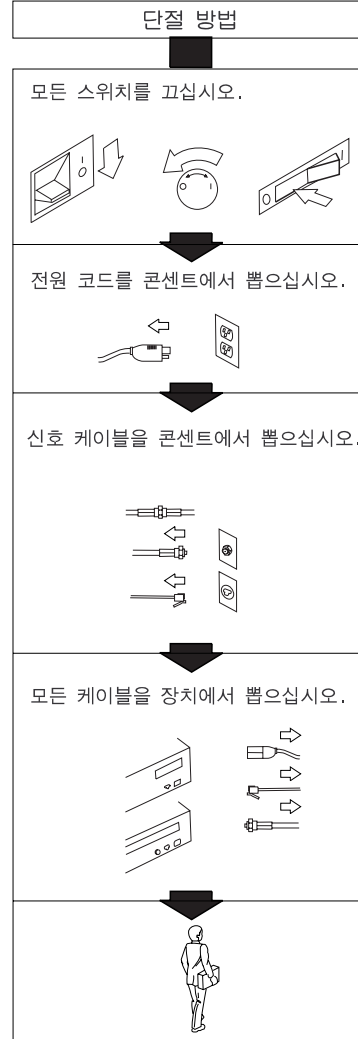

Note: In the UK, by law, the power cord must be disconnected after the telephone line cable.

주의:

리튬 배터리는 화재, 폭발 또는 심각한 화상을 유발할 수 있습니다.

재충전, 분해, 섭씨 100도(화씨 212도) 이상으로 과열하거나 셀에 직접 납땜하거나 태우거나 셀 내용물을 물에 노출시키지 마십시오.

아이들의 손이 닿지 않게 하십시오.

이 IBM 제품에 대해 지정된 부품 번호로만 교체하십시오.

다른 배터리를 사용할 경우 화재나 폭발의 위험이 있습니다.

이 배터리에는 극성이 있습니다. 극성을 바꾸지 마십시오. 현지 법에 의거하여 배터리를 폐기하십시오.

Safety Information-Italian

 **PERICOLO**

Per evitare scosse elettriche, non collegare o scollegare cavi o effettuare installazioni, riconfigurazioni o manutenzione di questo prodotto durante un temporale.

 **PERICOLO**

Per evitare scosse elettriche:

- Il cavo di alimentazione deve essere collegato a una presa munita di terra di sicurezza e propriamente cablata.
- Tutte le unita' esterne di questo prodotto, devono essere collegate a prese munite di terra di sicurezza e propriamente cablate.

 **PERICOLO**

Quando possibile, collegare o scollegare i cavi di segnale con una mano così da evitare il rischio di scosse, derivante dal contatto con due superfici a diverso potenziale elettrico.



PERICOLO:

La corrente elettrica di alimentazione del telefono e dei cavi di comunicazione e' pericolosa. Per evitare scosse elettriche collegare e scollegare i cavi, nella sequenza mostrata in figura, quando si installa, si trasporta o si tolgono i coperchi di questo prodotto o delle unita' ad esso collegate. Non maneggiare i cavi di interconnessione durante temporali.

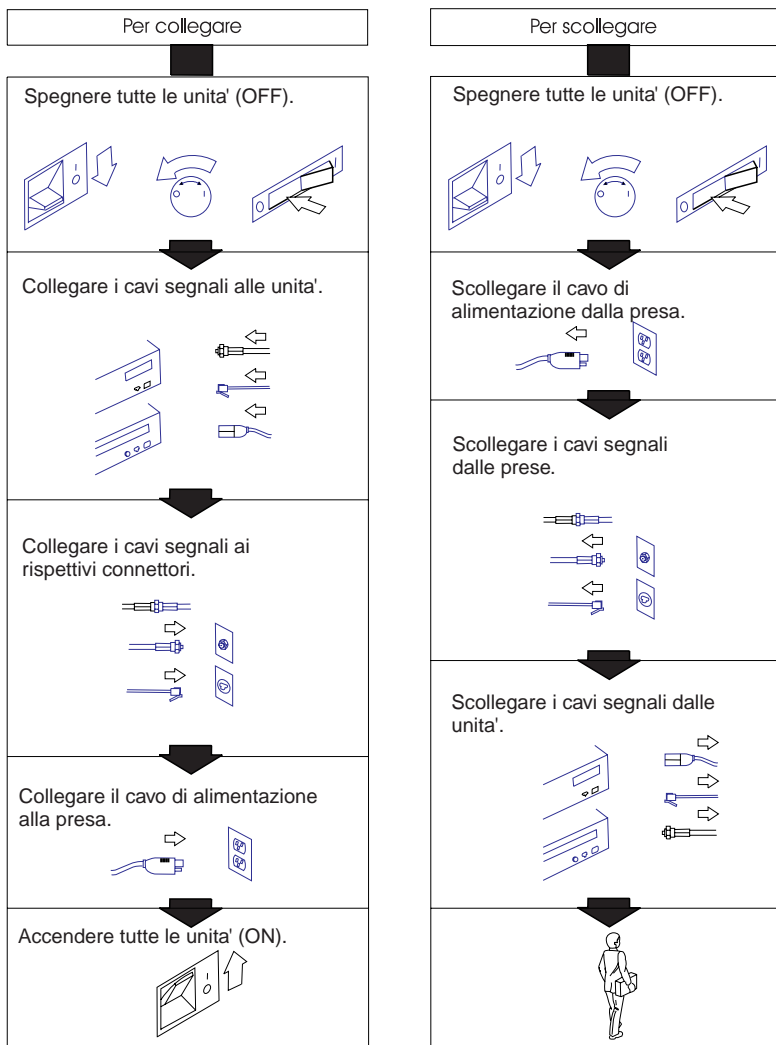

Attenzione:

Una batteria al litio può incendiarsi, esplodere o causare ustioni. Non ricaricarla, non smontarla, non riscaldarla ad una temperatura superiore a 100° C, non saldarla, non incenerirla, non gettarla in acqua.

Tenere la batteria lontano dalla portata dei bambini.

Sostituirla soltanto con una batteria contrassegnata dal numero parte specifico per questo prodotto IBM. L'utilizzo di un altro tipo di batteria può determinare rischi di incendio o di esplosione. Il connettore della batteria è polarizzata; non tentare di invertire la polarità.

Smaltire la batteria secondo la normativa in vigore (D.Lgs. 22 del 5/2/97) e successive disposizioni nazionali e disposizioni locali.

Safety Information-Spanish

**PELIGRO**

Para evitar peligro de descargas, no conecte o desconecte ningún cable, ni realice ninguna instalación, mantenimiento o reconfiguración de este producto durante una tormenta eléctrica.

**PELIGRO**

Para evitar peligro de descargas:

- El cable de alimentación debe estar conectado a una toma de alimentación adecuadamente cableada y con toma de tierra.
- Cualquier equipo al cual se conecte este producto debe estar también conectado a tomas de alimentación adecuadamente cableadas.

**PELIGRO**

Cuando sea posible, utilice una mano para conectar o desconectar los cables de señal para impedir que se produzcan posibles descargas eléctricas al tocar dos superficies con potencial eléctrico distinto.



PELIGRO: La corriente eléctrica de la alimentación, teléfono y cables de comunicación es peligrosa. Para evitar peligro de descargas cuando instale, mueva o abra las cubiertas de este producto o de un disp. conectado, conecte y desconecte los cables tal como se muestra a continuación.

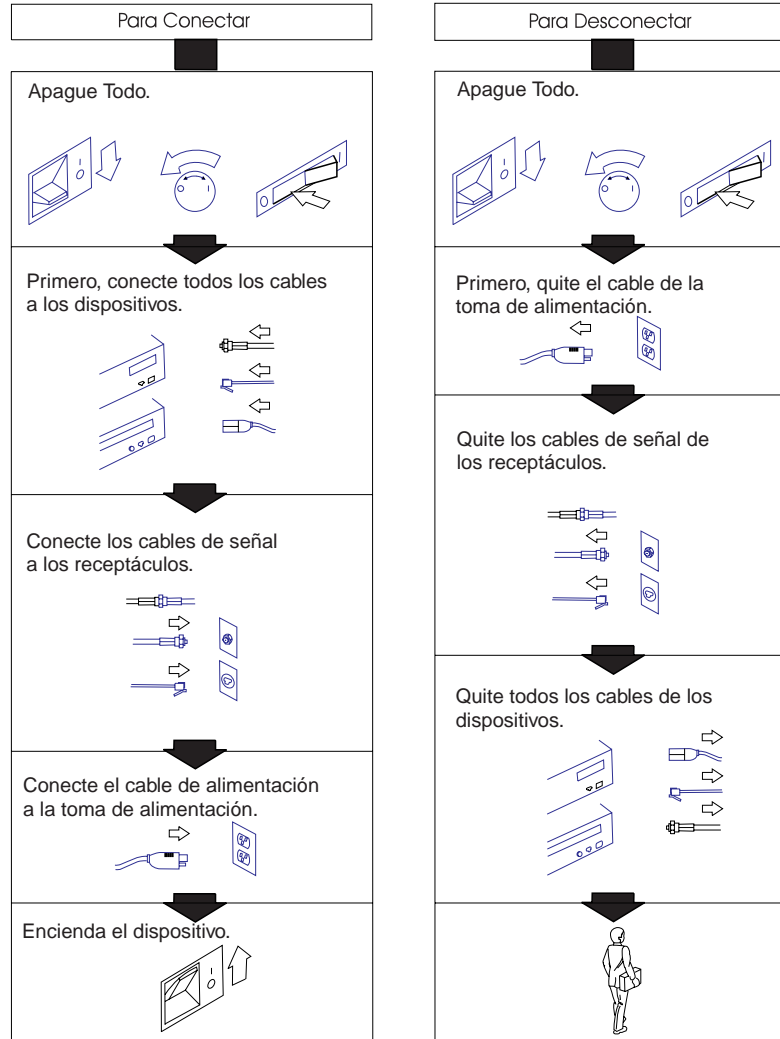

Precaución:

Una batería de litio puede causar un incendio, una explosión o quemaduras graves. No recargar, desmontar, calentar por encima de los 100 grados C (212 grados F), soldar directamente a la pila, incinerar o mojar el contenido de la pila.

Manténgala alejada de los niños.

Sustitúyala sólo con el número de pieza que se especifica para este producto IBM. El uso de una batería distinta puede causar riesgos de incendio o explosión. El conector de batería está polarizado; no intente invertir la polaridad.

Deseche la batería se acuerdo con la normativa local.

Safety Information-German

**VORSICHT**

Um gefährliche Spannungen zu vermeiden, dürfen während eines Gewitters an diesem Gerät keine Kabel angeschlossen oder gelöst werden, ferner keine Installation, Wartung oder Rekonfiguration durchgeführt werden.

**VORSICHT**

Aus Sicherheitsgründen

- darf das Netzkabel nur an eine Schutzkontaktsteckdose angeschlossen werden.
- dürfen für den Anschluß anderer Geräte an den Drucker auch nur Schutzkontaktsteckdosen verwendet werden.

**VORSICHT**

Die Signalkabel nach Möglichkeit mit einer Hand anschließen oder lösen, um gefährliche Körperströme zu vermeiden, die bei Berühren zweier Flächen mit möglicherweise unterschiedlichen elektrischen Potentialen auftreten können.



Elektrische
Sicherheit:

Gefährliche Spannungen an Netz-, Telefon- und Übertragungskabeln. Bei Installation, Transport oder Öffnen des Gerätegehäuses oder angeschlossenen Einheiten die Kabel wie abgebildet anschließen bzw. lösen. Bei Gewittern dürfen keine Kabel angeschlossen bzw. gelöst werden.

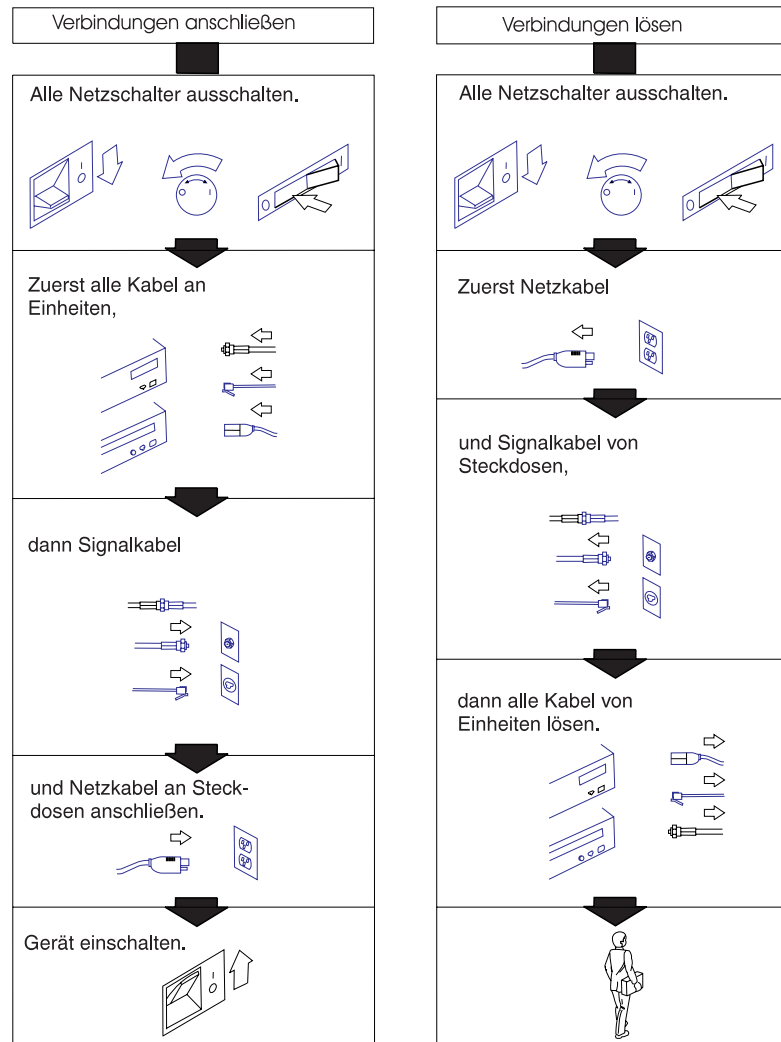

Achtung:

Lithiumbatterien sind feuergefährlich, explosiv und können schwere Verbrennungen verursachen. Batterie nicht wiederaufladen, öffnen oder über 100 Grad Celsius erhitzen; die Zelle nicht direkt anlöten, verbrennen oder den Inhalt der Zelle mit Wasser in Berührung bringen.

Batterie nicht in Reichweite von Kindern aufbewahren.

Eine verbrauchte Batterie nur durch eine Batterie mit der für dieses IBM Produkt spezifizierten Teilenummer ersetzen. Andere Batterien können sich entzünden oder explodieren. Der Batterieanschluß hat zwei verschiedene Pole; beim Anschließen die Pole nicht vertauschen.

Batterie gemäß den örtlichen Richtlinien für Sondermüll entsorgen.

Safety Information-Traditional Chinese



為了避免雷擊，在閃電期間，請勿連接或拔掉本裝置上的任何電纜線，或請勿安裝、維修或重新架構本產品。



為了避免雷擊：

- 電源線必須連接到接線及接地正確的插座。
- 本產品所連接的設備也必須連接到接線正確的插座。



儘可能使用單手來連接或拔掉信號電纜，以避免因接觸兩不同電位的平面，而受到電擊。



危險： 電源、電話及通信電纜上均有電流通過，為了避免電擊，在安裝、移動本產品，或開啟本產品的蓋子或與本產品連接之裝置的蓋子時，請依照下列「連接」及「拔掉」電纜線的步驟操作。

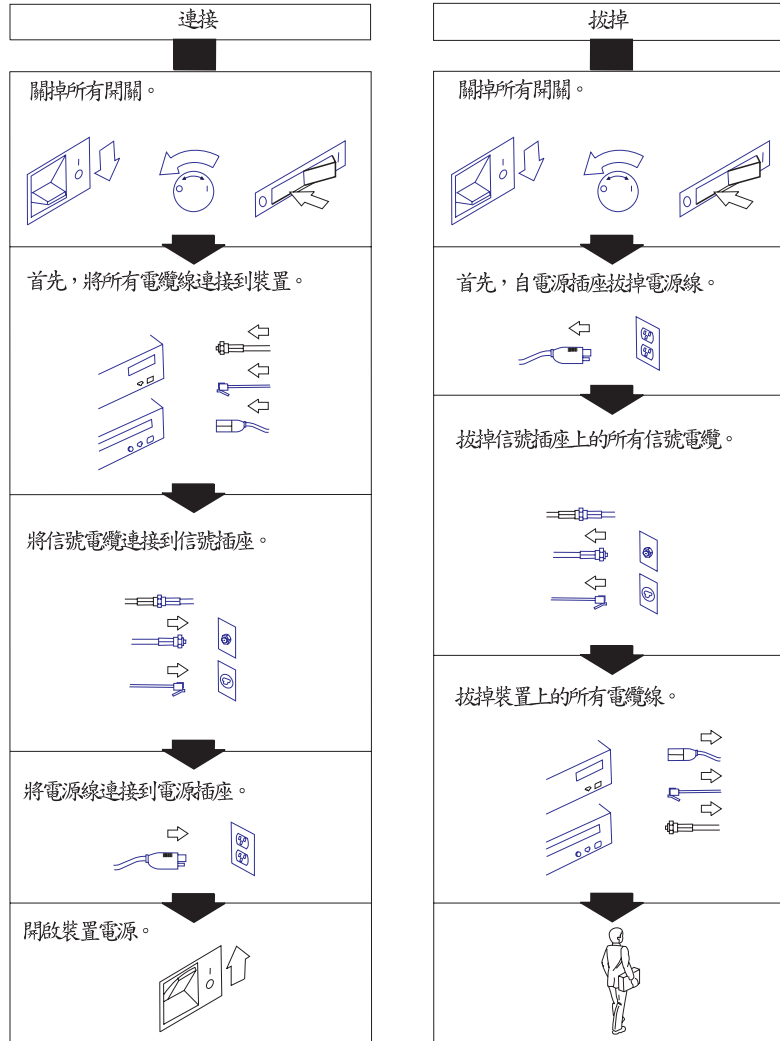

註：英國法律規定，需在電源線接妥後，才可連接電話線。

註：英國法律規定，需在電話線拔掉後，才可拔掉電源線。

注意：

锂电池可能会引起火灾、爆炸或严重烧伤。

请勿对锂电池进行充电、分解、加热超过 100 摄氏度（212 华氏度）、直接焊接、焚烧或置于水中。

请将电池放在孩童够不到的地方。

更换电池时只能使用指定产品。

使用其它电池可能有引起火灾或爆炸的危险。

电池接头带有极性，请勿掉换极性。
请按照当地法规处理电池。

Glossary

This glossary includes terms and definitions from:

- *American National Standard Dictionary for Information Systems*, ANSI X3.172-1990, copyright 1990 by the American National Standards Institute (ANSI). Copies may be purchased from the American National Standards Institute, 11 West 42nd Street, New York, New York 10036. Definitions are identified by the symbol (A) after the definition.
- The *Information Technology Vocabulary*, developed by Subcommittee 1, Joint Technical Committee 1, of the International Organization for Standardization and the International Electrotechnical Commission (ISO/IEC JTC1/SC1). Definitions of published parts of this vocabulary are identified by the symbol (I) after the definition; definitions taken from draft international standards, committee drafts, and working papers being developed by ISO/IEC JTC1/SC1 are identified by the symbol (T) after the definition, indicating that final agreement has not yet been reached among the participating National Bodies of SC1.

A

active. (1) Able to communicate on the network. A token-ring network adapter is active if it is able to transmit and receive on the network (2) Operational. (3) Pertaining to a node or device that is connected or is available for connection to another node or device. (4) Currently transmitting or receiving.

adapter. (1) In the point-of-sale terminal, a circuit card that, with its associated software, enables the terminal to use a function or feature. (2) In a LAN, within a communicating device, a circuit card that, with its associated software and/or microcode, enables the device to communicate over the network.

address. (1) In data communication, the IEEE-assigned unique code or the unique locally administered code assigned to each device or workstation connected to a network. (2) A character or group of characters that identifies a register, a particular part of storage, or some other data source or destination. (A) (3) To refer to a device or an item of data by its address. (I) (A) (4) The location in the storage of a computer where data is stored.

addressing. (1) The assignment of addresses to the instructions of a program. (2) In data communication, the way in which a station selects the station to which it is to send data.

alphanumeric. Pertaining to data consisting of letters, digits, and usually other characters, such as punctuation marks. (T) (A)

analog. (1) Pertaining to data consisting of continuously variable physical quantities. (A) (2) Contrast with *digital*.

application. (1) A collection of one or more programs that work together to accomplish goals for a business. (2) A set of executable files and data files required to perform a desired function, which can consist of multiple programs running on different workstations.

architecture. A logical structure that encompasses operating principles including services, functions, and protocols. See *network architecture*.

attach. (1) To connect a device physically. (2) To make a device a part of a network logically. Compare with *connect*.

attaching device. Any device that is physically connected to a network and can communicate over the network.

B

bit. Either of the digits 0 or 1 when used in the binary numeration system. Synonymous with binary digit. (T)

bus. (1) In a processor, a physical facility on which data is transferred to all destinations, but from which only addressed destinations may read in accordance with appropriate conventions. (2) A network configuration in which nodes are interconnected through a bidirectional transmission medium. (3) One or more conductors used for transmitting signals or power. (A)

C

cash drawer. An optional I/O device attached to a point-of-sale terminal. The cash drawer contains a till. The cash drawer will open upon receiving a command. See *till*.

CPU. The central processing unit of a computer.

circuit. (1) A logic device. (2) One or more conductors through which an electric current can flow.

cluster. (1) A station that consists of a control unit (a cluster controller) and the terminals attached to it. (2) A group of APPN nodes that have the same network ID and the same topology database. A cluster is a subset of a NETID subnetwork. (3) In high-availability cluster multiprocessing (HACMP), a set of independent systems (called nodes) that are organized into a

network for the purpose of sharing resources and communicating with each other.

collision. (1) An unwanted condition that results from concurrent transmissions on a channel. (T) (2) When a frame from a transmitting adapter encounters any other signal in its path (frame, noise, or another type of signal), the adapter stops transmitting and a collision is registered.

command. (1) A request for performance of an operation or execution of a program. (2) A character string from a source external to a system that represents a request for system action.

component. (1) Any part of a network other than an attaching device, such as an IBM 8228 Multistation Access Unit. (2) Hardware or software that is part of a functional unit.

configuration. (1) The devices and programs that make up a system, subsystem, or network. (A) See also *system configuration*. (2) In the IBM StorePlace Distributed Data Services for OS/2, program options that are initially set at installation, and that can be changed later. Changing these options requires an IPL. These changes must be performed by a programmer or store operations personnel. These options are used to tune the product's use of the operating system and machine resources.

connect. In a LAN, to physically join a cable from a station to an access unit or network connection point. Contrast with *attach*.

controller. A unit that controls input/output operations for one or more devices.

cursor. A movable point of light (or a short line) that indicates where the next character is to be entered on the display screen.

D

data. (1) A representation of facts, concepts, or instructions in a formalized manner suitable for communication, interpretation, or processing by human or automatic means. (I) (A) (2) Any representations such as characters or analog quantities to which meaning is or might be assigned. (A)

data file. A collection of related data records organized in a specific manner; for example, a payroll file (one record for each employee, showing such information as rate of pay and deductions) or an inventory file (one record for each inventory item, showing such information as cost, selling price, and number in stock.) See also *data set*, *file*.

data processing system. A system, including computer systems and associated personnel, that

performs input, processing, storage, output, and control functions to accomplish a sequence of operations on data. (A) (I)

data set. Logically related records treated as a single unit. See also *file*.

DBCS. See *double-byte character set*.

device. (1) A mechanical, electrical, or electronic contrivance with a specific purpose. (2) An input/output unit such as a terminal, display, or printer. See also *attaching device*.

diagnostic diskette. A diskette containing diagnostic modules or tests used by computer users and service personnel to diagnose hardware problems.

diagnostics. Modules or tests used by computer users and service personnel to diagnose hardware problems.

digital. (1) Pertaining to data in the form of digits. (A) Contrast with *analog*. (2) Pertaining to data consisting of numerical values or discrete units.

DIP switch. A two-position switch on a circuit board that is preset to control certain functions. The user can change the position of a DIP switch to satisfy special requirements.

disk. A round, flat, data medium that is rotated in order to read or write data. (T) See also *diskette*, *hard-disk drive*.

disk operating system (DOS). A computer operating system that can perform only one task at a time.

diskette. A thin, flexible magnetic disk permanently enclosed in a protective jacket. A diskette is used to store information for processing.

diskette drive. The mechanism used to seek, read, and write data on diskettes.

display. (1) A visual presentation of data. (2) A device that presents visual information to the point-of-sale terminal operator and to the customer.

distributed. Physically separate but connected by cables.

DOS. See *disk operating system*.

double-byte character set (DBCS). A set of characters in which each character is represented by 2 bytes. Languages such as Japanese, Chinese, and Korean, which contain more symbols than can be represented by 256 code points, require double-byte character sets. Because each character requires 2 bytes, the typing, display, and printing of DBCS characters requires hardware and programs that support DBCS. Contrast with *single-byte character set*.

DRAM. Dynamic RAM. See *RAM*.

driver. A software component that controls a device.

dump. (1) To record, at a particular instant, the contents of all or part of one storage device in another storage device. Dumping is usually for the purpose of debugging. (T) (2) Data that has been dumped. (T)

DVD-ROM. Digital-video-disk read-only memory.

E

error message. A message that is issued because an error has been detected.

F

FCC. See *Federal Communications Commission*.

feature. A part of an IBM product that may be ordered separately by the customer.

Federal Communications Commission (FCC). A board of commissioners appointed by the President under the Communications Act of 1934, having the power to regulate all interstate and foreign communications by wire and radio originating in the United States.

field. On a data medium or a storage medium, a specified area used for a particular category of data; for example, a group of character positions used to enter or display wage rates on a panel. (T)

file. A named set of records stored or processed as a unit. (T) For example, an invoice may form a record and the complete set of such records may form a file. See also *data set*.

.

FSB. Another name for the system bus. The system bus is also called the frontside bus, memory bus, local bus, or host bus.

flash memory. A data-storage device that is programmable, erasable, and does not require continuous power. The chief benefit of flash memory over other programmable and erasable data storage devices is that it can be reprogrammed without being removed from the circuit board.

formatted diskette. A diskette on which track and sector control information has been written and that can be used by the computer to store data. **Note:** A diskette must be formatted before it can receive data.

frame . (1) The unit of transmission in some LANs, including the IBM Token-Ring Network and the IBM PC Network. It includes delimiters, control characters, information, and checking characters. On a token-ring network, a frame is created from a token when the token has data appended to it. On a token-bus network

(IBM PC Network), all frames including the token frame contain a preamble, start delimiter, control address, optional data and checking characters, end delimiter, and are followed by a minimum silence period. (2) A housing for machine elements. (3) In synchronous data link control (SDLC), the vehicle for every command, every response, and all information that is transmitted using SDLC procedures. Each frame begins and ends with a flag.

function. (1) A specific purpose of an entity, or its characteristic action. (A) (2) In data communications, a machine action such as a carriage return or line feed. (A)

G

Ghz. The abbreviation for gigahertz. One GHz represents 1 billion cycles per second. The speed of microprocessors, called the clock speed, often is measured in gigahertz.

H

hard-disk drive. In a personal computer system unit, a disk storage device that reads and writes on rigid magnetic disks. It is faster and has a larger storage capacity than a diskette and is permanently installed. Synonymous with *fixed disk*.

HID. See *human interface devices*.

hot pluggable. Refers to a hardware component that can be installed or removed without disturbing the operation of any other resource that is not connected to, or dependent on, this component.

human interface devices (HID). Devices which allow humans to interact and communicate with a computer. Examples are a keyboard or a mouse.

hot plugging. Process of installing connections to the serial bus while the system is running and without powering down.

hot unplugging. Process of removing connections from the serial bus while the system is running and without powering down.

hypertext. (1) A method of presenting text in discrete units, or nodes, that are connected by links for navigation. (2) Text designed to be read or accessed in a nonlinear manner using nodes that are connected by links for navigation.

I

I/O. See *input/output*.

I/O device. A device in a data processing system by means of which data can be entered into the system, received from the system, or both. (I) (A)

IBM Disk Operating System (DOS) . A disk operating system based on MS-DOS that operates with all IBM-compatible personal computers.

IEEE. Institute of Electrical and Electronics Engineers.

input/output (I/O). (1) Pertaining to a device whose parts can perform an input process and an output process at the same time. (I) (2) Pertaining to a functional unit or channel involved in an input process, output process, or both, concurrently or not, and to the data involved in such a process.

integrated. Arranged together as one unit.

interference. (1) The prevention of clear reception of broadcast signals. (2) The distorted portion of a received signal.

interrupt. (1) A suspension of a process, such as execution of a computer program, caused by an external event and performed in such a way that the process can be resumed. (A) (2) To stop a process in such a way that it can be resumed. (3) A means of passing processing control from one software or microcode module or routine to another, or of requesting a particular software, microcode, or hardware function.

J

jabber. Transmission by a data station beyond the time interval allowed by the protocol. (T)

K

K. When referring to storage capacity, a symbol that represents two to the tenth power, or 1024.

keyboard. A group of numeric keys, alphabetic keys, special character keys, or function keys used for entering information into the terminal and into the system.

L

LAN. See *local area network*.

LAN adapter. The circuit card within a communicating device (such as a personal computer) that, together with its associated software, enables the device to be attached to a LAN.

LED. Light-emitting diode.

light-emitting diode (LED). A semiconductor chip that gives off visible or infrared light when activated.

line. On a terminal, one or more characters entered before a return to the first printing or display position.

link. (1) The logical connection between nodes including the end-to-end link control procedures. (2) The combination of physical media, protocols, and programming that connects devices on a network. (3) In computer programming, the part of a program, in some cases a single instruction or an address, that passes control and parameters between separate portions of the computer program. (4) To interconnect items of data or portions of one or more computer programs. (5) In SNA, the combination of the link connection and link stations joining network nodes. See also *link connection*. **Note:** A link connection is the physical medium of transmission; for example, a telephone wire or a microwave beam. A link includes the physical medium of transmission, the protocol, and associated devices and programming; it is both logical and physical.

link connection. (1) All physical components and protocol machines that lie between the communicating link stations of a link. The link connection may include a switched or leased physical data circuit, a LAN, or an X.25 virtual circuit. (2) In SNA, the physical equipment providing two-way communication and error correction and detection between one link station and one or more other link stations. (3) In the IBM Store System, the logical link providing two-way communication of data from one network node to one or more other network nodes.

load. In computer programming, to enter data into memory or working registers.

local area network (LAN). A computer network located on a user's premises within a limited geographical area. **Note:** Communication within a LAN is not subject to external regulations; however, communication across the LAN boundary may be subject to some form of regulation.

logon. The procedure for starting up a point-of-sale terminal or store controller for normal sales operations by sequentially entering the correct security number and transaction number. Synonymous with *sign-on*.

M

magnetic ink character reader (MICR). An input unit that reads characters by magnetic ink character recognition. (A)

magnetic ink character recognition. (1) MICR. Character recognition of magnetic ink characters. (T) (2) The identification of characters through the use of magnetic ink.

MB. See *megabyte*.

Mbps. One million bits per second.

megabyte (MB) . A unit of measure for data. 1 megabyte = 1 048 576 bytes.

memory. Program-addressable storage from which instructions and other data can be loaded directly into registers for subsequent execution or processing.

memory key. A USB removable storage device.

message. (1) An arbitrary amount of information whose beginning and end are defined or implied. (2) A group of characters and control bit sequences transferred as an entity. (3) In telecommunication, a combination of characters and symbols transmitted from one point to another. (4) A logical partition of the user device's data stream to and from the adapter. See also *error message*, *operator message*.

MICR. See magnetic ink character reader and magnetic ink character recognition.

modular flash drive. A small, portable flash memory card that plugs into a computer's USB port and functions as a portable hard drive. USB flash drives are small enough to be carried in a pocket and can plug into any computer with a USB drive. USB flash drives have less storage capacity than an external hard drive, but are smaller and more durable because they do not contain any internal moving parts.

module. A program unit that is discrete and identifiable with respect to compiling, combining with other units, and load; for example, the input to, or output from, an assembler, compiler, linkage editor, or executive routine.

N

network. (1) A configuration of data processing devices and software connected for information interchange. (2) An arrangement of nodes and connecting branches. Connections are made between data stations.

network architecture. The logical structure and operating principles of a computer network. **Note:** The operating principles of a network include those of services, functions, and protocols.

noise. (1) A disturbance that affects a signal and that can distort the information carried by the signal. (2) Random variations of one or more characteristics of any entity, such as voltage, current, or data. (3) Loosely, any disturbance tending to interfere with normal operation of a device or system.

nonvolatile random access memory (NVRAM) . Random access memory that retains its contents after electrical power is shut off. Contrast with *volatile memory*.

NVRAM. See nonvolatile random access memory.

O

operating system. Software that controls the execution of programs and that may provide services such as resource allocation, scheduling, input/output control, and data management. Although operating systems are predominantly software, partial hardware implementations are possible. (T)

Operating System/2® (OS/2®). A set of programs that control the operation of high-speed large-memory IBM Personal Computers providing multitasking. Contrast with *Disk Operating System (DOS)*.

operator. A person who operates a machine.

operator message. A message from the operating system or a program telling the operator to perform a specific function or informing the operator of a specific condition within the system, such as an error condition.

option. (1) A specification in a statement, a selection from a menu, or a setting of a switch, that can be used to influence the execution of a program. (2) A hardware or software function that can be selected or enabled as part of a configuration process. (3) A piece of hardware (such as a network adapter) that can be installed in a device to modify or enhance device function.

OS. Operating system.

OS/2. Operating System/2.

P

page. The information displayed at the same time on the screen of a display device.

panel. (1) A thin flat sheet, usually (a) of pressed metal and carrying controls and indicators, (b) of glass, or (c) of plastic. (2) A formatted display of information that appears on a display screen.

parallel port. A port that transmits the bits of a byte in parallel along the lines of the bus, one byte at a time, to an I/O device. On a personal computer, it is used to connect a device that uses a parallel interface, such as a dot matrix printer, to the computer. Contrast with *serial port*.

PC. See *personal computer*.

personal computer (PC). A desk-top, free-standing, or portable microcomputer that usually consists of a system unit, a display, a keyboard, one or more diskette drives, internal fixed-disk storage, and an optional printer. PCs are designed primarily to give independent computing power to a single user and are inexpensively priced for purchase by individuals or small businesses. Examples include the various models of the IBM Personal Computers.

plug. (1) A connector for attaching wires from a device to a cable, such as a store loop. A plug is inserted into a receptacle or plug. (2) To insert a connector into a receptacle or socket.

Plug and Play (PnP). Pertaining to the capability of a hardware or software component to be installed on a system with minimal effort and to be available for use immediately thereafter.

PnP. See *Plug and Play*.

point-of-sale (POS). A method of providing information to support sales and of collecting the resulting sales information from retail devices located in stores.

port. (1) An access point for data entry or exit. (2) A connector on a device to which cables for other devices such as display stations and printers are attached. Synonymous with *socket*.

POS. See *point-of-sale*.

POST. Power-on self-test.

power-on self-test (POST). A series of diagnostic tests that are run automatically each time the computer's power is switched on.

problem determination. The process of determining the source of a problem; for example, a program component, machine failure, telecommunication facilities, user or contractor-installed programs or equipment, environmental failure such as a power loss, or user error.

procedure. (1) A set of related control statements that cause one or more programs to be performed. (2) A set of instructions that gives a service representative a step-by-step procedure for tracing a symptom to the cause of failure.

processor. In a computer, a functional unit that interprets and executes instructions. (A) (I)

protocol. (1) A set of semantic and syntactic rules that determine the behavior of functional units in achieving communication. (I) (2) A specification for the format and relative timing of information exchanged between communicating parties.

R

RAM. See *random access memory*.

random access memory (RAM). A computer's or adapter's volatile memory, which can be accessed nonsequentially.

read. To acquire or to interpret data from a storage device, from a data medium, or from another source. (I) (A)

real-time. (1) Pertaining to the actual time during which a physical process occurs. (2) Pertaining to data collected concurrently with physical events, so that the results of the collection operation may be used to influence the sequence of events.

receive. To obtain and store information transmitted from a device.

record. A collection of related items of data, treated as a unit; for example, in stock control, each invoice could constitute one record. A complete set of such records may form a file.

repeater. A device that amplifies or regenerates data signals in order to extend the range of transmission between devices in a network.

S

SBCS. See *single-byte character set*.

scanner. A device that examines the bar code on merchandise tickets, credit cards, and employee badges and generates analog or digital signals corresponding to the bar code.

serial port. On personal computers, a port used to attach devices such as display devices, letter-quality printers, modems, plotters, and pointing devices such as light pens and mice; it transmits data one bit at a time. Contrast with *parallel port*.

signal. A variation of a physical attribute, used to convey data. (A)

single-byte character set (SBCS). Single-byte character set. A character set in which each character is represented by a one-byte code. Contrast with *double-byte character set*.

socket. (1) An opening that holds something. (2) Synonym for *port*.

source. The origin of any data involved in a data transfer.

subsystem. A secondary or subordinate system, usually capable of operating independently of, or asynchronously with, a controlling system. (T)

switch. (1) A device for making and breaking electrical connections, for making a selection, or for requesting a function or operation. (2) On an adapter, a mechanism used to select a value for, enable, or disable a configurable option or feature.

system. (1) In data processing, a collection of people, machines, and methods organized to accomplish a set of specific functions. (I) (A) See also *data processing system*, *operating system*, and *system unit*. (2) In the IBM StorePlace Distributed Data Services for OS/2, a group of nodes for which files are managed.

system board. In a system unit, the main circuit board that supports a variety of basic system devices, such as a keyboard or a mouse, and provides other basic system functions.

system bus. The unit that connects the CPU to the main memory on the system board.

system configuration. A process that specifies the devices and programs that form a particular data processing system.

system unit. (1) A part of a computer that contains the processing unit and may contain devices such as disk and diskette drives. (2) In an IBM Personal Computer, the unit that contains the processor circuitry, read-only memory (ROM), random access memory (RAM), and the I/O channel. It may have one or more disk or diskette drives. (3) In an IBM Store System terminal, the part of the terminal that contains the processing unit, ROM, RAM, disk and diskette drives, and the I/O channel.

T

terminal. In data communication, a device, usually equipped with a keyboard and a display, that is capable of sending and receiving information.

till. A tray in the cash drawer of the point-of-sale terminal, used to keep the different denominations of bills and coins separated and easily accessible.

transmit. To send information from one place for reception elsewhere. (A)

twisted pair. A transmission medium that consists of two insulated electrical conductors twisted together. (A)

typematic. The ability of a key on a keyboard to repeatedly type a character as long as it is held down.

U

Universal Serial Bus (USB). A serial interface standard for telephony and multimedia connections to personal computers.

Universal Serial Bus (USB), powered. A powered-USB connector provides additional power from the host system. A powered-USB receptacle consists of two connectors stacked vertically inside the common housing. The upper connector contains four contacts that are used for powering the attached device.

unshielded twisted pair (UTP). One or more twisted pairs of copper wire in the unshielded voice-grade cable commonly used to connect a telephone to its wall jack.

user. (1) A category of identification defined for file access protection. (2) A person using a program or system.

USB. See *Universal Serial Bus*.

V

version . A separately licensed program that usually has significant new code or new function.

vital product data (VPD). Information about the computer, such as machine type and model or serial number, stored in the BIOS.

volatile memory. Memory that loses its contents when power is turned off.

VPD. See *vital product data*.

Part number index

Part Number	Asm-Index	Page	Part Number	Asm-Index	Page
12X1000	1-2	101	42V3938	1-21	101
12X1001	1-2	101	42V3939	1-	101
12X1002	1-2	101	42V3940	1-29	101
12X1009	1-23	101	42V3941	1-29	101
12X1036	1-6	101	42V3943	1-12	101
12X1110	1-24	101	42V3944	1-	101
12X1129	4-6	109	42V3945	1-18	101
12X1129	5-6	111	42V3946	1-18	101
14R0157	2-5	105	42V3947	1-	101
20P0308	5-5	111	42V3948	1-20	101
39X8908	1-22	101	42V3949	1-20	101
40N5755	1-17	101	42V3950	1-14	101
41A3641	1-	101	42V3951	1-	101
41D0171	1-	101	42V3952	1-	102
41D0210	5-1	111	42V3953	1-15	101
41D0211	4-2	109	42V3956	1-	102
41D0211	5-2	111	42V3957	1-	102
41D0212	4-	109	42V3958	3-3	107
41D0214	2-1	105	42V3959	3-4	107
41D0216	2-	105	42V3960	3-1	107
41D0261	4-1	109	42V3961	3-1	107
41D9746	1-	102	42V3964	2-2	105
41P0212	5-	111	42V3965	2-3	105
42N5755	3-2	107	42V3966	4-3	109
42V3682	1-28	101	42V3966	5-3	111
42V3886	1-1	101	42V3967	4-4	109
42V3887	1-1	101	42V3967	5-4	111
42V3888	1-1	101	42V3969	1-	101
42V3889	1-3	101	42V3980	1-	101
42V3890	1-3	101	45P6222	1-	101
42V3891	1-3	101	47P9273	2-4	105
42V3892	1-6	101			
42V3893	1-5	101			
42V3894	1-5	101			
42V3895	1-5	101			
42V3897	1-4	101			
42V3922	1-10	101			
42V3923	1-10	101			
42V3924	1-7	101			
42V3925	1-9	101			
42V3926	1-9	101			
42V3927	1-11	101			
42V3928	1-11	101			
42V3930	1-16	101			
42V3931	1-13	101			
42V3932	1-26	101			
42V3933	1-27	101			
42V3935	1-25	101			
42V3936	1-19	101			
42V3937	1-8	101			

Index

Special characters

102

Numerics

- 12-inch display dimensions 118
- 15-inch display dimensions 119
- 15-pin serial port
 - connector pin assignments 127
- 17-inch display dimensions 120
- 4610 SureMark printer, installing 95

A

- about this guide xix
- accessibility of publications xix
- adapter cable, RJ-45 to 9-pin conversion 29
- advanced BIOS window 14
- altitude limits 130
- audience xix
- Australia new Zealand 134
- Avis de conformité aux normes d'Industrie Canada 133

B

- base plate, removing and replacing 58
- base-foot countertop mounting
 - mounting the system 71
- batteries
 - disposal xvii
- battery, system board 52
- BIOS
 - flashing procedure 17
 - repairing 18
 - update 18
- blank, PC card 60
- board 50

C

- Canadian emission compliance 133
- cash drawer
 - mounting 79
 - troubleshooting 20
- Cash drawer
 - connector pin assignments 129
- cash drawer, countertop and full-size 84
- checklist, problem diagnosis 19
- Chinese Class A warning statement 135
- clearing
 - CMOS settings 15
 - system password 15
- clock, real-time 16
- CMOS
 - clearing 15

- CMOS (*continued*)
 - recovery 23
 - settings
 - restoring defaults 15
 - standard features 14
- CMOS setup utility
 - configuring the COM ports 16
- CMOS Setup Utility
 - Advanced BIOS Features 14
 - main window 13
 - starting the 13
- compatible products 11
- configuration, main window 13
- configuring
 - I/O devices 14
 - power savings 14
- configuring the COM ports 16
- connector
 - 15-pin serial pin assignments 127
 - cash drawer pin assignments 129
 - Ethernet pin assignments 127
 - external video pin assignments 128
 - headphone pin assignments 125
 - integrated customer display pin assignments 129
 - keyboard pin assignments 124
 - microphone pin assignments 125
 - MSR pin assignments 122
 - Universal Serial Bus (USB) pin assignments 124
- connector pin assignments 125
- connector pin, assignments 122
- connectors
 - speaker pin assignments 122
- connectors, power, and brightness controls 5
- countertop
 - integration tray legend 77
 - integration tray mounting 74
 - mounting the system 69
- countertop and full-size cash drawer 84
- countertop mount 71
- customer display, integrated 66

D

- damage from electrostatic discharge 136
- default CMOS settings
 - clearing 15
 - restoring 15
- diagnosing problems
 - preliminary checklist 19
- diagnosing problems and troubleshooting 19
- dimensions 115, 118
- display
 - removing and replacing 35
- display restrictions 8
- Display tablet 35
- disposal of equipment xvii
- disposing of used products xvii

- distributed character display and APA display, mounting to a cash drawer 93
- documentation, related xix
- drawer, countertop and full-size cash 84
- Driver for Windows, IBM UPOS 7
- dual video adapter 63

E

- EAS xviii
- electronic article surveillance xviii
- electronic article surveillance device xviii
- electronic emissions 133
- electrostatic discharge (ESD) 136
- end of life disposal xvii
- environmental
 - notices xvii
 - statements xvii
- equipment disposal xvii
- Ethernet
 - connector pin assignments 127
- EU 133
- European conformity statement 133
- external connectors 122
- external video, connector pin assignments 128

F

- FCC statement 133
- features
 - system management 9
- features, optional 4
- field replaceable units 99
- filler panels without a printer, installing 79
- flash bios 18
- flash BIOS update procedure 17
 - power interruption 18
- flash drive 67
- flash, update 18
- FRU 99
- FRU catalog
 - how to use 99
- full-size cash drawer, countertop and 84

H

- handling static-sensitive devices xviii, 28
- headphone
 - connector pin assignments 125
- heatsink assembly 54
- height 115
- humidity limits 130

I

- IBM UPOS Drivers for Windows 7
- industry standard devices 9
- information, task 19
- installation procedures 93
- installing additional peripheral devices 93

- installing filler panels without a printer 79
- installing the 4610 printer onto the integration tray 89
- installing the keyboard-integration tray on a cash drawer 87
- Integrated customer display
 - connector pin assignments 129
- integration tray, keyboard, mounting 84
- integration tray, non-keyboard 74

J

- Japanese power line harmonics compliance statement 134
- Japanese Voluntary Control Council for Interference (VCCI) Statement 134
- jumper locations, system board 52

K

- keyboard 125
 - connector pin assignments 124
 - troubleshooting 22
- keyboard connector 124
- keyboard-integration tray mounting 84
- knowledgebase 19
- Korean Communications Statement 135

L

- Load defaults 15

M

- magnetic stripe reader xviii
 - connector pin assignments 122
- main window, configuration 13
- management features, system 9
- management programs, system 9
- memory keys, supported 17
- memory modules
 - removing and replacing 56
- memory modules and industry standards 57
- mercury-added statement xviii
- microphone
 - connector pin assignments 125
- model number location 11
- Models 545 and 565
 - connectors, power, and brightness controls 5
 - features and models summary 2
- models and features 2
- Models E45 and E65 3
- Models P45 and P65 3
- modular flash drive 67
- modular service tools 29
- mounting
 - base plate to a countertop 71
 - configurations 69
 - Countertop and full-size cash drawe 84
 - countertop integration tray mounting 74
 - non-keyboard-integration tray 74

- mounting the integration tray to a countertop 84
- mounting the SurePOS 500 69
- mouse connector 125
- MSR xviii
 - removing and replacing 59
 - troubleshooting 21
- MSR location xviii

N

- non-keyboard-integration tray
 - mounting the system 74
- notices 131
 - environmental xi
 - safety xi
 - safety translation xi
- notices, electronic emissions 133

O

- opening the I/O tailgate cover 32
- operating system and display restrictions 8
- operating systems 7
- operating systems supported 7
- operating systems, understanding the supported video
 - resolutions and 7
- optional features 4, 59
- optional memory 67

P

- part numbers
 - integration tray keyboard, cash drawer and countertop 104
 - integration tray non-keyboard, countertop 108
 - integration turn on— keyboard, cash drawer 110
 - Models 545 and 565 101
 - optional peripherals 107
 - power cords 113
- parts catalog 19, 99
- password
 - clearing 15
 - setting 15
- PC card adapter
 - removing and replacing 61
- PC health status 15
- peripheral devices 93
 - 4610 SureMark Models TF6 or TF7 printers 95
 - installing 93
- pictorial overview of removal and replacements 26
- pin assignments 122
 - Ethernet connector 127
- planning information 115
- PnP/PCI configurations option 14
- power consumption 121
- power cords
 - part numbers 113
- power management window 14
- power ratings, port 121
- power requirements 121

- power saving
 - configuration 14
- power supply
 - removing and replacing 46
- power supply latch arm
 - opening 47
- power, connectors, and brightness controls 5
- power, input voltage 121
- printer installation, 4610 95
- printer, installing filler panels without a 79
- problem determination 13
- problem diagnosis
 - preliminary checklist 19
- problem diagnosis, start 19
- problem symptoms
 - audio is not working 22
 - blank screen 20
 - cash drawer
 - display status does not match action 21
 - does not open 20, 21
 - does not open correctly 21
 - does not open smoothly 21
 - does not stay closed 20
 - diskette drive does not work 22
 - keyboard does not work 22
 - MSR not reading 21
 - no power light on operator display tablet 20
 - no power light on tower unit 20
 - operator display backlight dark or dim 21
 - running fan 22
 - touch screen not working 21
- processor fan 54
- processor module 55
- product
 - disposal xvii
- products and services 131
- products, compatible 11
- publications xix
 - related xix
 - website xix

R

- radio interference 134
- real-time clock and CMOS 16
- rear cover 31
- recover from flash BIOS update error condition 18
- recovery, CMOS 23
- related publications xix
- remote management 10
- removal and replacement procedures 29, 35, 54, 59, 61
 - base plate 58
 - cable tie bar 45
 - covers 30
 - front cover 30
 - hinge cover 34
 - opening the I/O tailgate cover 32
 - rear cover 31
 - top cover 33
 - display tablet cable 36

removal and replacement procedures *(continued)*
 front bezel and LCD assembly 37
 HDD and HDD bracket 41
 HDD cables 44
 HDD fan and bracket 43
 hinge assembly 40
 memory modules 56
 modular flash drive 67
 operator card 39
 optional features
 integrated customer display 66
 MSR 59
 MSR hole plug 60
 PC card blank 60
 speaker 64
 video adapter card 63
 power supply 46
 power supply latch arm 47
 processor fan/heatsink assembly 55
 processor module 55
 rear connector panel (tailgate) 48
 system board 50
 system-board battery 52
 tablet, display 35
 removing and replacing FRUs 25
 processor module 55
 Repair 18
 repairing the flash bios 18
 replacing FRUs 25
 requirements
 power 121
 researching the knowledgebase 19
 resolutions and operating systems, understanding the
 supported video 7
 restoring default CMOS settings 15
 restrictions, display 8
 RJ-45
 connector pin assignments 126
 RJ-45 connectors 125
 running diagnostics and troubleshooting 13

S

safety
 laser xi
 notice translations xi
 notices xi
 safety information xi, 137, 139
 Safety Information English 139
 safety notices 141
 serial connectors 125
 serial number location 11
 serial number, location 14
 service personnel tools 29
 setting
 changing, clearing password 15
 clearing CMOS 15
 restoring default CMOS 15
 setup, how to enter 13
 size of unit 118

skills needed to install, configure, and administer this
 product xix
 solid state hard file 67
 speaker 64
 speaker connector 122
 speaker, connector pin assignments 122
 specifications
 height 115
 weight 115
 standard interface 9
 starting the CMOS Setup Utility 13
 static-sensitive devices, handling xviii, 28
 summary window, configuration 13
 support xix
 Supported devices 9
 supported memory keys 17
 supported video resolutions and operating systems,
 Understanding the 7
 system board
 jumper locations 52
 jumper settings 52
 removing and replacing 50
 system management features 9
 system management programs 9
 system specifications 115
 system specs 115

T

tablet, removing and replacing 35
 tailgate connector
 removing and replacing 48
 tailgate cover, opening 32
 Taiwan contact information 136
 Taiwan recycle statement 136
 Taiwanese Class A Warning Statement 135
 tapping twice, touch screen 13
 task information 19
 temperature limits 130
 TF6 and TF7 95
 tools, service personnel 29
 touch screen
 troubleshooting 21
 touch screen, tapping twice 13
 trademarks 137
 tray dimensions 116
 troubleshooting 20
 preliminary checklist 19

U

understanding the supported video resolutions and
 operating systems 7
 universal serial bus (USB)
 connector pin assignments 124
 update flash BIOS 17
 UPOS Drivers for Windows, IBM 7
 URL, support 16
 USB antenna specification 4
 usb port connectors 124

Update April 23, 2007

V

video card

 removing and replacing 63

video resolutions and operating systems, understanding
 the supported 7

W

Wake on Ring 14

web site

 IBM Retail Store Solutions 16

Web sites xix

weight 115

Readers' comments—we would like to hear from you

SurePOS 500 Series
Hardware Service Guide for Models 545 and 565

Publication No. SY27-0423-01

We appreciate your comments about this publication. Please comment on specific errors or omissions, accuracy, organization, subject matter, or completeness of this book. The comments you send should pertain to only the information in this manual or product and the way in which the information is presented.

For technical questions and information about products and prices, please contact your IBM branch office, your IBM business partner, or your authorized remarketer.

When you send comments to IBM, you grant IBM a nonexclusive right to use or distribute your comments in any way it believes appropriate without incurring any obligation to you. IBM or any other organizations will only use the personal information that you supply to contact you about the issues that you state on this form.

Comments:

Thank you for your support.

Submit your comments using one of these channels:

- Send your comments to the address on the reverse side of this form.

If you would like a response from IBM, please fill in the following information:

Name

Address

Company or Organization

Phone No.

E-mail address



Fold and Tape

Please do not staple

Fold and Tape



NO POSTAGE
NECESSARY
IF MAILED IN THE
UNITED STATES

BUSINESS REPLY MAIL

FIRST-CLASS MAIL PERMIT NO. 40 ARMONK, NEW YORK

POSTAGE WILL BE PAID BY ADDRESSEE

IBM Corporation
Retail Store Solutions Information Development
Department ZBDA
IBM Corporation
P.O. Box 12195
Research Triangle Park, NC 27709-9990

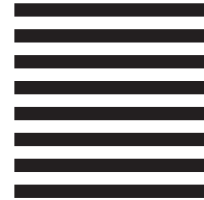

Fold and Tape

Please do not staple

Fold and Tape



Update April 23, 2007

SY27-0423-01

