

SurePOS 700 Series

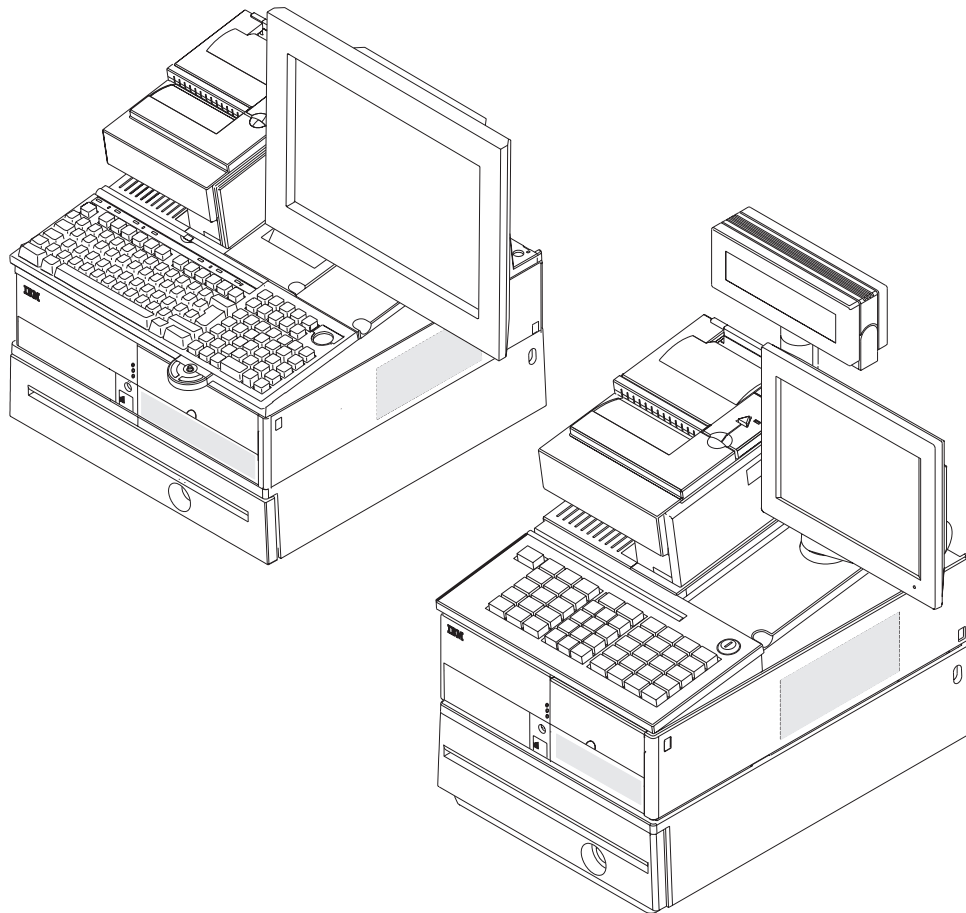

# SurePOS 700-723/743/783 Systems, Installation, and Operations Guide





SurePOS 700 Series



# SurePOS 700-723/743/783 Systems, Installation, and Operations Guide

**Note**

Before using this information and the product it supports, be sure to read the general information under Appendix A, "Safety information," on page 101 and Appendix B, "Notices," on page 107.

**October 2007**

This edition applies to IBM SurePOS 700 Series Models 723, E23, 743, C43, E43, 783, and E83 and to all subsequent releases and modifications until otherwise indicated in new editions.

Current versions of Retail Store Solutions documentation are available on the IBM Retail Store Solutions Web site at <http://www.ibm.com/solutions/retail/store/support>. Click **Publications**.

A form for reader's comments is also provided at the back of this publication. If the form has been removed, address your comments to:

IBM Corporation  
Retail Store Solutions Information Development  
Department ZBDA  
PO Box 12195  
Research Triangle Park, North Carolina 27709 USA

When you send information to IBM, you grant IBM a nonexclusive right to use or distribute whatever information you supply in any way it believes appropriate without incurring any obligation to you.

© **Copyright International Business Machines Corporation 2007. All rights reserved.**

US Government Users Restricted Rights – Use, duplication or disclosure restricted by GSA ADP Schedule Contract with IBM Corp.

# Contents

|  |     |
|--|-----|
| <b>Tables</b> . . . . .  | vii |
| <b>Figures</b> . . . . .   | ix  |
| <b>About this guide</b> . . . . .  | xi  |
| Who should read this guide . . . . .   | xi  |
| How this guide is organized . . . . .  | xi  |
| Related publications . . . . .   | xi  |
| SurePOS 700 Series Models 723, E23, 743, C43, E43, 783, and E83 important driver information . . . . . | xii |
| Uninterruptible power supply option . . . . .  | xii |
| Publications accessibility . . . . .   | xii |
| Providing feedback . . . . .   | xii |
| <b>Chapter 1. Introducing the SurePOS 700 models</b> . . . . .   | 1   |
| Features and options . . . . .   | 2   |
| System memory . . . . .  | 3   |
| Service processor . . . . .  | 3   |
| Video function . . . . .   | 3   |
| Local area network . . . . .   | 4   |
| Audio and headphones . . . . .   | 4   |
| PC I/O . . . . .   | 5   |
| Optional USB DASD . . . . .  | 5   |
| USB support . . . . .  | 5   |
| Unique software interface . . . . .  | 5   |
| Physical characteristics . . . . .   | 6   |
| Dimensions . . . . .   | 6   |
| Controls and indicators . . . . .  | 6   |
| Connectors . . . . .   | 7   |
| IBM SurePorts Point-of-Sale connections . . . . .  | 9   |
| Cooling . . . . .  | 11  |
| Environmental and temperature . . . . .  | 11  |
| Power . . . . .  | 12  |
| Power switch operation . . . . .   | 13  |
| Power management . . . . .   | 14  |
| Uninterruptible power supply (optional) . . . . .  | 14  |
| I/O devices . . . . .  | 16  |
| Cash drawers . . . . .   | 17  |
| Voltage setting for the 4689 DBCS SurePOS Receipt Journal printer . . . . .                            | 18  |
| Powered USB connectors . . . . .   | 18  |
| System and driver support . . . . .  | 20  |
| Operating systems . . . . .  | 20  |
| Drivers . . . . .  | 20  |
| BIOS . . . . .   | 20  |
| Compatibility . . . . .  | 20  |
| Hardware . . . . .   | 20  |
| Software . . . . .   | 21  |
| Preparing to call for service . . . . .  | 22  |
| <b>Chapter 2. Installing and setting up the system</b> . . . . .                                       | 23  |
| Before you begin . . . . .   | 23  |
| Supported operating systems . . . . .  | 23  |
| Determining your configuration . . . . .   | 23  |

|  |           |
|--|-----------|
| Your order and packaging . . . . .   | 23        |
| Setup procedures . . . . .   | 23        |
| (Optional) Replacing the front lock plug with a lock . . . . .                               | 23        |
| Step 1. Installing your internal options . . . . .   | 24        |
| Step 2. Installing the expansion housing and the optional UPS (wide units<br>only) . . . . . | 24        |
| Step 3. Installing the covers . . . . .  | 31        |
| Step 3 (alternate): Installing the coverless front bezel . . . . .                           | 34        |
| Step 4. Installing the slanted I/O tray (wide units only) . . . . .                          | 37        |
| Step 5. Routing the cables through the slanted I/O tray . . . . .                            | 37        |
| Step 6. Attaching your I/O devices . . . . .   | 38        |
| Step 7. Installing the fillers on a slanted I/O tray . . . . .                               | 38        |
| Step 8. Connecting the power . . . . .   | 42        |
| Step 9. Running the BIOS configuration utility . . . . .                                     | 42        |
| <b>Chapter 3. Installing internal options . . . . .</b>                                      | <b>43</b> |
| Operating the front lock or lock plug . . . . .  | 43        |
| Opening the drive bay door . . . . .   | 43        |
| Removing the covers . . . . .  | 43        |
| Removing the pullout tray . . . . .  | 47        |
| Installing a feature card . . . . .  | 48        |
| Installing memory modules . . . . .  | 49        |
| <b>Chapter 4. Installing external options . . . . .</b>                                      | <b>51</b> |
| Before you begin . . . . .   | 51        |
| Attaching the cables to the system unit . . . . .  | 51        |
| Securing IBM USB POS keyboard cables . . . . .   | 52        |
| Securing the cable using cable ties . . . . .  | 52        |
| Installing the system unit on a cash drawer . . . . .  | 54        |
| Setting the jumper for the correct voltage for non-IBM cash drawers . . . . .                | 54        |
| Installing the cash drawer . . . . .   | 54        |
| Installing the cash drawer coin roll cutter (compact cash drawer only) . . . . .             | 57        |
| Installing I/O trays . . . . .   | 58        |
| Installing an I/O tray on the system unit . . . . .  | 58        |
| Installing a slanted I/O tray on the full-size cash drawer . . . . .                         | 59        |
| Installing the fillers . . . . .   | 59        |
| Installing the tape-holder kit . . . . .   | 60        |
| Installing the printer . . . . .   | 61        |
| Installing the 40-character LCD . . . . .  | 62        |
| Installing the 40-character VFD . . . . .  | 64        |
| Installing the character/graphics display . . . . .  | 67        |
| Installing the display post with a snap . . . . .  | 67        |
| Installing the display post with a base . . . . .  | 69        |
| Installing the guidance label . . . . .  | 71        |
| Attaching an IBM SurePoint Solution . . . . .  | 71        |
| Installing and removing lock inserts . . . . .   | 72        |
| Preparing to install a lock or a blank lock insert . . . . .                                 | 72        |
| Installing a lock insert . . . . .   | 72        |
| Installing a blank lock insert . . . . .   | 73        |
| Removing a lock insert . . . . .   | 74        |
| Removing a blank lock insert . . . . .   | 75        |
| Installing the keyboard-V and the PLU keyboard . . . . .                                     | 75        |
| Changing the keytop labels . . . . .   | 75        |
| Installing a vertical stand . . . . .  | 75        |
| Installing cables . . . . .  | 76        |
| Installing the cable guide and the cable guide arm assembly . . . . .                        | 76        |

|  |            |
|--|------------|
| Routing the cables . . . . .   | 77         |
| <b>Chapter 5. Diagnostics and configuration settings . . . . .</b>             | <b>81</b>  |
| Service and diagnostics . . . . .  | 81         |
| Using the IBM BIOS Setup Utility . . . . .                                     | 81         |
| Navigation and menus . . . . .   | 82         |
| Saving settings . . . . .  | 82         |
| Boot device order . . . . .  | 82         |
| Restoring CMOS default settings . . . . .                                      | 83         |
| <b>Chapter 6. Operating POS I/O devices . . . . .</b>                          | <b>85</b>  |
| Displays . . . . .   | 85         |
| Adjusting the controls on video displays . . . . .                             | 86         |
| Cash drawers . . . . .   | 86         |
| Lock positions . . . . .   | 87         |
| Document storage area under cash drawer . . . . .                              | 88         |
| Cash drawer options . . . . .  | 88         |
| Using the cash drawer coin roll cutter (compact cash drawer only) . . . . .    | 89         |
| Keyboards . . . . .  | 90         |
| Manager's lock . . . . .   | 91         |
| Function keys . . . . .  | 91         |
| Keyboard status indicator lights . . . . .                                     | 92         |
| Using the USB keyboard-V . . . . .   | 93         |
| Using the USB PLU keyboard with display . . . . .                              | 95         |
| Entering data at your terminal . . . . .                                       | 98         |
| Operating card readers . . . . .   | 98         |
| Cleaning the card reader . . . . .   | 98         |
| Printers. . . . .  | 98         |
| <b>Chapter 7. Troubleshooting. . . . .</b>                                     | <b>99</b>  |
| Preliminary checklist . . . . .  | 99         |
| Problem isolation . . . . .  | 99         |
| <b>Appendix A. Safety information . . . . .</b>                                | <b>101</b> |
| <b>Appendix B. Notices . . . . .</b>   | <b>107</b> |
| Electronic emission notices . . . . .  | 109        |
| Federal Communications Commission (FCC) statement . . . . .                    | 109        |
| European Union EMC Directive conformance statement . . . . .                   | 109        |
| Industry Canada Class A Emission Compliance statement . . . . .                | 110        |
| Avis de conformité aux normes d'Industrie Canada . . . . .                     | 110        |
| Germany. . . . .   | 110        |
| Australia and New Zealand . . . . .  | 110        |
| Chinese Class A warning statement . . . . .                                    | 111        |
| Japanese power line harmonics compliance statement . . . . .                   | 111        |
| Japanese Voluntary Control Council for Interference (VCCI) statement . . . . . | 111        |
| Korean communications statement . . . . .                                      | 111        |
| Taiwanese Class A warning statement . . . . .                                  | 112        |
| Taiwan contact information . . . . .   | 112        |
| Cable ferrite requirement . . . . .  | 112        |
| Electrostatic Discharge (ESD) . . . . .  | 112        |
| Product Recycling and disposal . . . . .                                       | 113        |
| Battery return program. . . . .  | 114        |
| For Taiwan: . . . . .  | 114        |
| For the European Union: . . . . .  | 114        |
| For California: . . . . .  | 115        |

Flat panel displays . . . . . 115  
Monitors . . . . . 115  
Trademarks. . . . . 115

**Appendix C. Intel software license agreement (final, single user) . . . . . 117**  
Important - read before copying, installing or using . . . . . 117  
    Copyright license. . . . . 117  
    Ownership of software and copyrights . . . . . 117  
    Limited media warranty . . . . . 117  
    Exclusion of other warranties . . . . . 117  
    Limitation of liability . . . . . 118  
    Termination of this agreement . . . . . 118  
    Applicable laws . . . . . 118  
    Government restricted rights . . . . . 118

**Index . . . . . 119**

---

## Tables

|   |    |
|---|----|
| 1. Model descriptions . . . . .                         | 1  |
| 2. Features and options . . . . .                       | 2  |
| 3. Available I/O ports . . . . .                        | 7  |
| 4. Connection icons definitions . . . . .               | 8  |
| 5. Port DC loads . . . . .                              | 12 |
| 6. Cash drawer jumper settings . . . . .                | 17 |
| 7. Cash drawer jumper settings . . . . .                | 18 |
| 8. Front panel LED status indicators. . . . .           | 42 |
| 9. CMOS jumper and pin location by model . . . . .      | 84 |
| 10. Settings for DIP switches SW3 and SW4 . . . . .     | 96 |
| 11. Actions to isolate the cause of a problem . . . . . | 99 |



---

# Figures

|   |    |
|---|----|
| 1. Example of the wide and narrow SurePOS 700 Series . . . . .            | 1  |
| 2. Front panel controls and indicators. . . . .                           | 6  |
| 3. Front panel of Models 743, C43, E43, 783, and E83 . . . . .            | 7  |
| 4. Rear panel . . . . .   | 8  |
| 5. Base configuration. . . . .  | 9  |
| 6. RS-232 and base configuration . . . . .                                | 9  |
| 7. RS-485 and base configuration . . . . .                                | 10 |
| 8. USB and base configuration. . . . .                                    | 11 |
| 9. UPS rear view. . . . .   | 15 |
| 10. Location of UPS configuration switches . . . . .                      | 16 |
| 11. Setting the cash drawer using the jumper override . . . . .           | 17 |
| 12. Location of the printer jumper on the I/O card . . . . .              | 18 |
| 13. Example of the powered USB port . . . . .                             | 19 |
| 14. Serial number and machine information on front and bottom . . . . .   | 22 |
| 15. Front lock plug in fully open position. . . . .                       | 24 |
| 16. Removing the front lock plug . . . . .                                | 24 |
| 17. Removing the retainer bracket . . . . .                               | 25 |
| 18. Aligning the expansion housing with the system unit. . . . .          | 26 |
| 19. Removing the sheet metal panel . . . . .                              | 27 |
| 20. Connecting the battery to the UPS . . . . .                           | 28 |
| 21. Saving the battery date label . . . . .                               | 28 |
| 22. Inserting the UPS . . . . .   | 29 |
| 23. Replacing the UPS retainer bracket . . . . .                          | 30 |
| 24. Installing the top cover. . . . .                                     | 31 |
| 25. Installing the rear door. . . . .                                     | 32 |
| 26. View of rear door lower tabs . . . . .                                | 32 |
| 27. Removing the blank for the UPS switch panel . . . . .                 | 33 |
| 28. Placement of bezel . . . . .  | 34 |
| 29. Placement of bezel . . . . .  | 35 |
| 30. Installing two mounting tabs into the slanted I/O tray. . . . .       | 37 |
| 31. Routing the cables through the slanted I/O tray. . . . .              | 38 |
| 32. Mounting locations for the fillers . . . . .                          | 39 |
| 33. Installing the display filler . . . . .                               | 40 |
| 34. Installing the keyboard filler . . . . .                              | 40 |
| 35. Installing the keyboard-replacement filler . . . . .                  | 41 |
| 36. Location of installed fillers . . . . .                               | 41 |
| 37. Removing the front bezel. . . . .                                     | 44 |
| 38. Opening the hinged rear door . . . . .                                | 45 |
| 39. Removing the top cover . . . . .                                      | 46 |
| 40. Removing the pullout tray from the unit frame . . . . .               | 47 |
| 41. Installing feature cards. . . . .                                     | 48 |
| 42. Replacing the memory modules . . . . .                                | 49 |
| 43. Pictorial steps to attach the cable with clips and brackets . . . . . | 52 |
| 44. Securing the cable with cable ties . . . . .                          | 53 |
| 45. Place the system unit on the cash drawer . . . . .                    | 55 |
| 46. Installing cash drawer cables . . . . .                               | 56 |
| 47. Install coin roll cutter . . . . .                                    | 57 |
| 48. Installing the slanted I/O tray . . . . .                             | 58 |
| 49. Installing two mounting tabs into the slanted I/O tray. . . . .       | 59 |
| 50. Removing the tape-holder latch . . . . .                              | 60 |
| 51. Snapping the tape-holder into place . . . . .                         | 60 |
| 52. Install the printer . . . . .   | 61 |
| 53. Assemble the post . . . . .   | 62 |

|  |    |
|--|----|
| 54. Slide display into holder . . . . .                                    | 62 |
| 55. Plug cable into display unit . . . . .                                 | 63 |
| 56. Assembling the display . . . . .                                       | 63 |
| 57. Attachment points for the display post . . . . .                       | 64 |
| 58. Assemble the post . . . . .  | 65 |
| 59. Routing the cable . . . . .  | 65 |
| 60. Placement of the display on the arm . . . . .                          | 66 |
| 61. Routing the cable . . . . .  | 66 |
| 62. Connecting the character/graphics display post. . . . .                | 67 |
| 63. Routing the character/graphics display cable . . . . .                 | 67 |
| 64. Installing the character/graphics display . . . . .                    | 68 |
| 65. Placing the post into the filler hole . . . . .                        | 68 |
| 66. Connecting the character/graphics display post. . . . .                | 69 |
| 67. Routing the cable . . . . .  | 69 |
| 68. Placement of the character/graphics display on the arm . . . . .       | 70 |
| 69. Routing the cable . . . . .  | 70 |
| 70. Installing the guidance label. . . . .                                 | 71 |
| 71. IBM SurePoint Solution display . . . . .                               | 71 |
| 72. Lock inserts and accessories . . . . .                                 | 72 |
| 73. Aligner positions . . . . .  | 72 |
| 74. Install a lock insert . . . . .  | 73 |
| 75. Align the lug with the slot in the lock cylinder . . . . .             | 74 |
| 76. Turn the locking screw. . . . .  | 74 |
| 77. Remove a lock insert . . . . .   | 74 |
| 78. Installing the keytop labels . . . . .                                 | 75 |
| 79. Placing the system unit on the vertical stand . . . . .                | 76 |
| 80. Installing the cable guide arm assembly . . . . .                      | 77 |
| 81. Extra cord length during routing . . . . .                             | 78 |
| 82. Cable assembly arm with cables securely in place . . . . .             | 79 |
| 83. Location of CMOS jumper - Models 743, C43, E43, 783, and E83. . . . .  | 83 |
| 84. Location of CMOS jumper - Models 723 and E23 . . . . .                 | 84 |
| 85. Character displays . . . . .   | 85 |
| 86. Controls on 9 in. monochrome display . . . . .                         | 86 |
| 87. Full-size cash drawer . . . . .  | 86 |
| 88. Compact cash drawer . . . . .  | 87 |
| 89. Lock positions . . . . .   | 87 |
| 90. Cash drawer depth-adjustment bar . . . . .                             | 88 |
| 91. Using the coin roll cutter . . . . .                                   | 89 |
| 92. Keyboard types for the SurePOS 700 . . . . .                           | 90 |
| 93. Manager's lock . . . . .   | 91 |
| 94. Example of S1 and S2 function keys . . . . .                           | 91 |
| 95. Location of keyboard status-indicator lights . . . . .                 | 92 |
| 96. Location of keyboard-V status indicators . . . . .                     | 93 |
| 97. USB keyboard-V volume control . . . . .                                | 94 |
| 98. Location of mode lock keys . . . . .                                   | 94 |
| 99. Location of system function keys . . . . .                             | 95 |
| 100. Location of USB PLU keyboard with display indicators . . . . .        | 95 |
| 101. Location of PLU keyboard DIP switches . . . . .                       | 96 |
| 102. Location of volume control on USB PLU keyboard with display . . . . . | 97 |
| 103. Location of system function keys . . . . .                            | 97 |
| 104. Reading a magnetic stripe card . . . . .                              | 98 |

---

## About this guide

Use this document to install and operate IBM® SurePOS™ 700 Series Models 723, E23, 743, C43, E43, 783, and E83.

---

## Who should read this guide

This guide is intended for the person who will install, set up, and manage the operation of the SurePOS 700 models.

---

## How this guide is organized

This guide is organized as follows:

- Chapter 1, “Introducing the SurePOS 700 models,” on page 1 covers the system specifications, options, and features of the SurePOS 700 Models 723, E23, 743, C43, E43, 783, and E83.
- Chapter 2, “Installing and setting up the system,” on page 23 provides hardware setup and software installation procedures.
- Chapter 3, “Installing internal options,” on page 43 details the procedures to install feature cards and memory modules into the system.
- Chapter 4, “Installing external options,” on page 51 details the procedures to attach displays, input/output devices, and printers to the system.
- Chapter 5, “Diagnostics and configuration settings,” on page 81 explains how to change and restore system configuration settings.
- Chapter 6, “Operating POS I/O devices,” on page 85 explains how to use common point-of-sale devices that might be attached to the system.
- Chapter 7, “Troubleshooting,” on page 99 provides a basic troubleshooting guide to diagnose problems with system operation.
- Appendix A, “Safety information,” on page 101 provides safety information and warnings.
- Appendix B, “Notices,” on page 107 provides detailed legal and disposal information.

---

## Related publications

These related IBM publications are also available from the IBM Retail Store Solutions Web site at <http://www.ibm.com/solutions/retail/store>:

- *Safety and Regulatory Information – Read This First*, GA27-4004
- *SurePOS 700 Series: SurePOS 700-723/743/783 Hardware Service Guide*, GY27-0424
- *SurePOS 700 Series: SurePOS 700-723/743/783 Operating System Installation Guide*, GA27-5002
- *Point-of-Sale: Options and I/O Devices Service Guide*, GC30-9737
- *SureMark 4610 Printers: User’s Guide*, GA27-4151
- *SureMark 4610 Printers: Hardware Service Guide*, GY27-0355
- *Point-of-Sale Subsystem: Programming Reference and User’s Guide*, SC30-3560
- *Point-of-Sale Subsystem: Installation, Keyboards, and Code Pages*, GC30-3623
- *4820 SurePoint Solution: Planning, Installation and Service Guide*, GA27-4231
- *4820 SurePoint Solution: System Reference*, SA27-4249

Diagnostic programs that are media-independent are downloadable from the IBM Retail Store Solutions Web site at <http://www.ibm.com/solutions/retail/store>. The use of generic drivers from manufacturer Web sites is not recommended.

---

## SurePOS 700 Series Models 723, E23, 743, C43, E43, 783, and E83 important driver information

The SurePOS 700 Series Models 723, E23, 743, C43, E43, 783, and E83 require new point-of-sale (POS) input/output (I/O) and hardware drivers. Existing drivers for Models 4694 and 4800 will not work properly with these products. This notice applies to all operating systems: DOS, 4690, Microsoft® Windows®, and Linux®. Additionally, a hard drive image for a predecessor product will not work properly. Be sure to download the appropriate drivers from the IBM Retail Store Solutions Web site at <http://www.ibm.com/solutions/retail/store>.

---

## Uninterruptible power supply option

This product contains a sealed lead acid battery. The battery must be recycled or disposed of properly. In the United States, IBM has established a collection process for reuse, recycling, or proper disposal of used IBM sealed acid batteries. For information about proper disposal of these batteries, contact IBM at 1-800-426-4333. You must have the IBM part number listed on the battery available before your call. For information about disposal of sealed acid batteries outside the United States, contact your local waste disposal facility or go to this URL:

<http://www.ibm.com/ibm/environment/products/batteryrecycle.shtml>

SurePOS 700 UPS batteries are a consumable item and, as such, you are responsible for replacing them. IBM warrants the original UPS battery for 90 days from the ship date to the customer or distributor. In the U.S. and Canada, you can purchase replacement batteries (P/N 23K8052) by calling 1-800-IBM-CALL (1-800-426-2225). If you are located outside of the U.S. and Canada, contact your IBM representative.

---

## Publications accessibility

The soft-copy version of this guide and other related publications are accessibility-enabled.

---

## Providing feedback

Your feedback is important in helping IBM provide accurate and high-quality information.

You can use either of these ways to provide feedback:

- Go to <http://www.ibm.com/solutions/retail/store>. Click **Support**, then click **Publications**. Click the **publication comments** within the introductory text. Provide the requested information and your comments. Be sure to include the name and form number of the document in the [Publication ID] field.
- Print and complete the form at the end of this document. Return the form to IBM by mail or by giving it to an IBM representative.

If applicable, include a reference to the specific location of the text (for example, the page or table number) on which you are commenting.

October 31, 2007

Between major revisions of this document, there might be minor technical updates. The latest version of this document is available on the Retail Store Solutions Web site at [www.ibm.com/solutions/retail/store/support/publications/](http://www.ibm.com/solutions/retail/store/support/publications/).



## Chapter 1. Introducing the SurePOS 700 models

The IBM SurePOS 700 Series Models 723, E23, 743, C43, E43, 783, and E83 are offered in a wide footprint and a narrow footprint. Your packaging options determine the width of the unit. A unique cover-set feature provides a broad selection of cover options and colors.

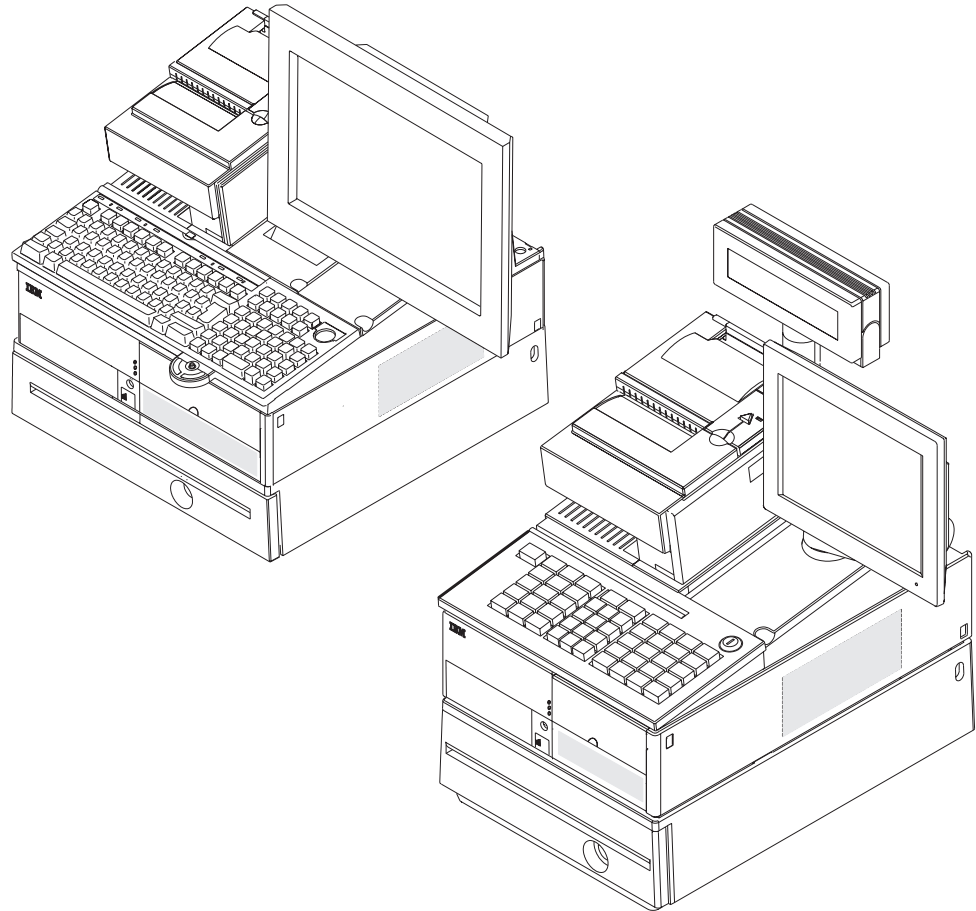

Figure 1. Example of the wide and narrow SurePOS 700 Series

Table 1 describes the available models and shows the processor that is standard with each model.

Table 1. Model descriptions

| <b>Entry products for cost-sensitive applications:</b>        |  |
|---|--|
| 723   | VIA C7-D 2.0 GHz   |
| E23   | VIA C7-D 2.0 GHz with Microsoft Windows Embedded for Point of Service (WEPOS) operating system preinstalled  |
| <b>Value products that balance cost and high performance:</b> |  |
| 743   | Intel® Celeron® 440 2.0 GHz  |
| C43   | <b>Controller model</b><br>Intel Celeron 440 2.0 GHz without SurePort adapters<br>512 MB DDR II memory, 80 GB hard drive and combo drive standard<br>This model does not have preinstalled software. |

Table 1. Model descriptions (continued)

|  |  |
|--|--|
| E43  | Intel Celeron 440 2.0 GHz with WEPOS preinstalled      |
| <b>High-performance products for intensive point-of-sale (POS) applications:</b> |  |
| 783  | Intel Core 2 Duo E4300 1.8 GHz                         |
| E83  | Intel Core 2 Duo E4300 1.8 GHz with WEPOS preinstalled |

## Features and options

Table 2 shows the standard installed features and options for baseline SurePOS 700 systems.

Table 2. Features and options

| Attribute                                  | Models 723 and E23  | Models 743, C43, and E43  | Models 783 and E83   |
|--|---|---|--|
| Processor                                  | VIA C7-D 2.0 GHz/800 MHz  | Intel Celeron 440 2.0 GHz/800 MHz                               | Intel Core 2 Duo E4300 1.8 GHz/800 Mhz   |
| Memory                                     | 533 MHz DDR2 DIMM<br>256 MB standard<br>2 GB maximum<br>2 slots                         | 667 MHz DDR2 DIMM<br>512 MB standard<br>4 GB maximum<br>2 slots | 667 MHz DDR2 DIMM<br>512 MB standard<br>4 GB maximum<br>2 slots                        |
| NVRAM                                      | 128 KB  |   |  |
| Service processor                          | Renesas H8S2116   |   |  |
| Hard disk (optional; one disk is standard) | Zero, one, or two<br>80 GB or larger<br>SATA II 7200 RPM<br>VIA RAID 0, 1               |   | Zero, one, or two<br>80 GB or 160 GB<br>or larger<br>SATA II 7200 RPM<br>VIA RAID 0, 1 |
| Video                                      | Two analog VGA interfaces<br>Dual display support standard                              |   |  |
| Video memory                               | 64 MB maximum, shared with system memory  | 256 MB maximum, shared with system memory                       |  |
| LAN  | 10/100 Mbps   | 10/100/1000 Mbps + Trusted Platform Module (TPM)                |  |
| Slots                                      | One PCI and one x1 lane PCI Express<br>(approximately ½ length; 195 mm/7.6 in. maximum) |   |  |
| DVD or CD-RW                               | Internal CD-RW/DVD<br>External Universal Serial Bus (USB)<br>Boot support included      |   |  |
| Audio, front                               | None  | Headphone out   |  |
| Audio, rear                                | Microphone in, line in, line out  |   |  |
| PC I/O                                     | PS/2 keyboard and mouse   |   |  |
|  | No USB on front   | One 12 V POS USB 2.0 on front                                   |  |
|  | Two PC USB 2.0 on rear  |   |  |
|  | Two standard RS-232 on rear   | Four standard RS-232 on rear                                    |  |
| Diskette drive                             | External USB (optional)   |   |  |
| Standby power                              | Internal UPS (optional - wide only)   |   |  |

## System memory

All system boards have two memory slots. The factory-installed base memory occupies one of the slots. An empty slot depends on the initial order for base memory.

Models 723 and E23 use 533 MHz DDR2 DIMMs: 256 MB standard, 2 GB maximum (two slots).

Models 743, C43, and E43 use 667 MHz DDR2 DIMMs: 512 MB standard, 4 GB maximum (two slots).

Models 783 and E83 use 667 MHz DDR2 DIMMs: 512 MB standard, 4 GB maximum (two slots).

**Note:** Use only memory provided by IBM Retail Store Solutions. Not all third-party memory modules work with every product. IBM performs extensive life and reliability testing to ensure that the memory offered by IBM will operate correctly over all voltage and temperature ranges.

## Service processor

SurePOS 700 Series Models 723, E23, 743, C43, E43, 783, and E83 include a complete implementation of a service processor to monitor system health.

LEDs provide a quick diagnosis of a critical system or device failure:

### Front panel

- Power (green)
- Hard disk drive (HDD) activity (green)
- INFO (amber)

### Behind the front door

- Processor fan failure (amber)
- System board failure (amber)
- Upper HDD failure (amber)
- Lower HDD failure (amber)
- Power supply failure (amber)

### On system board

- Memory has power (red)
- Service processor heartbeat (red)
- Backup BIOS active (red)

### On riser

- Riser not seated (red)

## Video function

The integrated chip set on the system board provides the video function. No separate VGA subsystem is provided. Video storage uses system dynamic random-access memory (DRAM) and uses technology that provides extra video memory as needed and releases it back to the operating system (OS) when not in use.

Using the BIOS setup, you can permanently allocate memory to system memory or to video memory.

Models 723 and E23 use an integrated video controller that can be configured to use up to 64 MB of system DRAM for video storage. It can display resolutions up to 1600x1200 on the primary VGA port, while the secondary VGA port is limited to 1024x768.

Models 743, C43, E43, 783, and E83 use an integrated video controller that can be configured to use up to 256 MB of system DRAM for video storage. The primary VGA port supports resolutions up to 2048x1536, while the secondary VGA port is limited to 1024x768.

Video drivers are available for many versions of Windows and Linux. Video support for the 4690 OS, Novell Linux Point of Service (NLPOS), and IBM Retail Environment for SUSE Linux Version 2 (IRES2) is already embedded in those operating systems. DOS uses the video subsystem in standard DOS modes.

## Local area network

IBM provides special local area network (LAN) drivers for Models 723 and E23 and for Models 743, C43, E43, 783, and E83.

**Note:** Existing LAN drivers for 4694 and for earlier models of the SurePOS 700 are not compatible with Models 723, E23, 743, C43, E43, 783, and E83.

Models 723 and E23 use a 10/100 Mbps Ethernet controller.

Models 743, C43, E43, 783, and E83 use a 10/100/1000 Mbps x1 lane PCI Express (PCI-E) plus TPM Ethernet controller.

The SurePOS 700 Series supports these additional protocols and standards:

- Dynamic Host Configuration Protocol (DHCP) and Preboot Execution Environment (PXE), but *not* for the Remote Program Load (RPL) or Novell NetWare protocols
- Wireless connectivity through the use of an additional PCI or PCI-E feature card or a USB adapter
- IEEE 802.3i 10/100/1000Base-T physical layer interfaces
- IEEE 802.3u autonegotiation
- Desktop Management Interface (DMI), Simple Network Management Protocol (SNMP), Windows Management Instrumentation (WMI), quality of service (QoS), and so forth
- IBM Wake on LAN®

## Audio and headphones

The SurePOS 700 Models 723 and E23 contains an AC97-compatible audio subsystem. The product is capable of driving conventional speakers or headphones with the line-out output, but cannot drive nonpowered speakers (such as the early models of the 4820 display with optional speaker kit).

The SurePOS 700 Models 743, C43, E43, 783, and E83 contain a high-definition audio subsystem.

Connecting headphones to the front headphone jack disconnects the line-out jack on the rear.

**Note:** The front headphone jack is not available on Models 723 and E23.

PC speaker tones are coupled into the audio subsystem (line-out); contact your IBM Support representative if you would like to change this default behavior.

## PC I/O

The core chip sets have standard interfaces for these devices:

- PS/2 keyboard and mouse
- Two RS-232 ports

**Note:** Models 743, C43, E43, 783, and E83 contain two additional RS-232 channels. Drivers are required to enable these ports (for all operating systems) and they are available through the IBM Retail Store Solutions Web site at <http://www.ibm.com/solutions/retail/store>. Because these ports are PCI devices and fully Plug and Play compliant, applications must use OS and BIOS calls to discover their locations in the system's I/O map. Also, these applications must be able to share the PCI interrupt structure, if interrupt support is required. Finally, these ports have an option to map them to standard COM3/COM4 PC-AT COM port addresses.

- Two PC USB 2.0 ports

**Note:** USB 1.1 devices can be used with USB 2.0 ports (at USB 1.1 speeds), and USB 2.0 devices will work on USB 1.1 ports (at USB 1.1 speeds).

## Optional USB DASD

External USB direct access storage devices (DASDs) such as HDDs, CD-ROMs, diskettes, or memory keys operate with the product; IBM provides USB boot support. Before use, test any specific USB device that is not offered by IBM Retail Store Solutions. This requirement is especially necessary due to the implementation differences between drive suppliers.

## USB support

The base subsystem is implemented on the main processor board and uses the core USB support provided by the system board chip set. SurePOS 700 Models 723, E23, 743, C43, E43, 783, and E83 support the USB 1.1. and 2.0 standard; and all system board USB controllers are Universal Host Controller Interface (UHCI) and Enhanced Host Controller Interface (EHCI) compliant.

## Unique software interface

For the software programmer, the SurePOS 700 appears as a PCI-based PC system unit with the usual PC peripherals. The unique POS function is packaged on the PCI riser card. These unique functions are also provided in the system unit:

- 128 KB of nonvolatile random access memory (NVRAM)
- A ROM bank that connects to the system ROM during power-on self-test (POST) to provide additional functionality and information
- An interface to the RS-485 (Electronic Industries Alliance [EIA] 485) subsystem, if the system is equipped with RS-485 ports<sup>1</sup>
- An interface to the POS USB subsystem<sup>1</sup>
- An interface to the POS RS-232 subsystem<sup>1</sup>

---

1. IBM drivers and operating systems isolate these changes from the application.

## Physical characteristics

This section gives you the physical characteristics for the SurePOS 700 Series Models 723, E23, 743, C43, E43, 783, and E83 for narrow, wide, and wide with uninterruptible power supply (UPS) models.

## Dimensions

The dimensions for the wide and narrow models are as follows:

| Footprint     | Width                 | Depth                 | Height                 | Weight                 |
|---------------|-----------------------|-----------------------|------------------------|------------------------|
| Wide          | 435 mm<br>(17.13 in.) | 475 mm<br>(18.70 in.) | 117.3 mm<br>(4.62 in.) | 11.8 kg<br>(30.64 lbs) |
| Narrow        | 320 mm<br>(12.60 in.) | 475 mm<br>(18.70 in.) | 117.3 mm<br>(4.62 in.) | 11.4 kg<br>(25.13 lbs) |
| Wide with UPS | 435 mm<br>(17.13 in.) | 475 mm<br>(18.70 in.) | 117.3 mm<br>(4.62 in.) | 18.4 kg<br>(40.57 lbs) |

## Controls and indicators

Figure 2 describes the front panel controls and indicators.

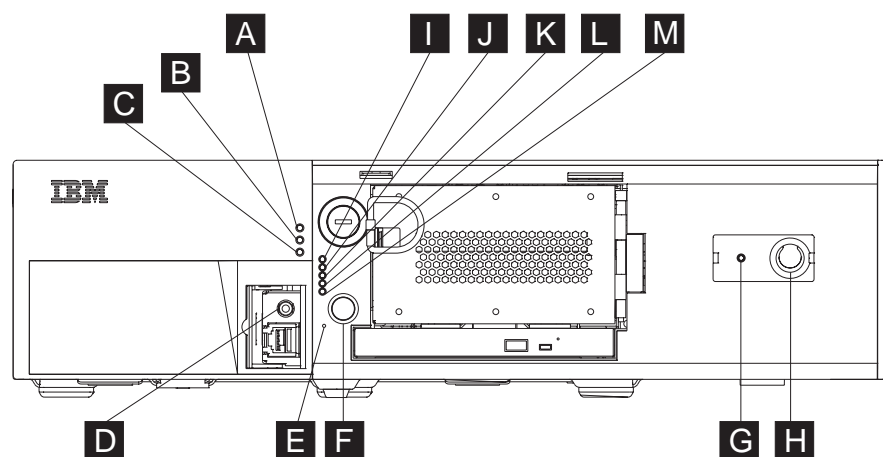

Figure 2. Front panel controls and indicators. Note: Use of the front headphone jack overrides the rear line-out jack.

- A** Power
- B** Hard disk or optical drive activity
- C** INFO
- D** Headphone jack (Models 743, C43, E43, 783, and E83 only)
- E** Recessed dump switch
- F** System power switch
- G** UPS indicator (only with wide footprint and UPS installed; otherwise covered)
- H** UPS switch (only with wide footprint and UPS installed; otherwise covered)
- I** LED 1, processor fan failure
- J** LED 2, system board failure
- K** LED 3, upper HDD failure
- L** LED 4, lower HDD failure
- M** LED 5, power supply failure

**Note:** **G** and **H** are available only if you install the optional UPS.

## Connectors

The SurePOS 700 Series offers a unique configuration for connecting POS input and output (I/O) devices. Most of the POS-specific I/O function is contained on a riser card that connects into the main processor board.

The SurePOS models support RS-485 POS I/O (4694 family), powered USB I/O (IBM SurePOS 700 family), and powered RS-232 I/O. A unique tailgate design, which includes IBM SurePort adapters, provides different configurations of I/O that you can later upgrade or change in the field. The rear I/O panels are attached to the riser card.

Table 3 provides a summary of the available I/O ports.

Table 3. Available I/O ports

| Connector                        | SurePOS 723     | SurePOS 743                                       | SurePOS 783 |
|----------------------------------|-----------------|---|-------------|
| Microphone in, line in, line out | Back            | Back + front headphone                            |             |
| USB                              | Two PC 2.0 back | Two PC USB 2.0 back<br>One 12 V POS USB 2.0 front |             |
| Dump switch                      | Front           |   |             |
| Ethernet                         | One back        |   |             |
| Analog video                     | Two back        |   |             |
| PS/2 keyboard                    | One back        |   |             |
| PS/2 mouse                       | One back        |   |             |
| RS-232 (EIA 232)                 | Two back        | Four back   |             |
| POS ports (USB, RS-485, RS-232)  | Choice          |   |             |

Figure 3 shows the 12 V USB and the headphone jack on the front panel of Models 743, C43, E43, 783, and E83.

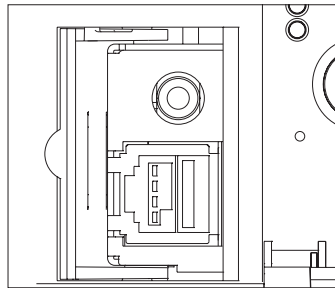

Figure 3. Front panel of Models 743, C43, E43, 783, and E83

Figure 4 shows a view of the rear-panel I/O connections: the top adapter is chosen based on application, while the bottom adapter is available on all models. Table 4 defines the icons that label each connection.

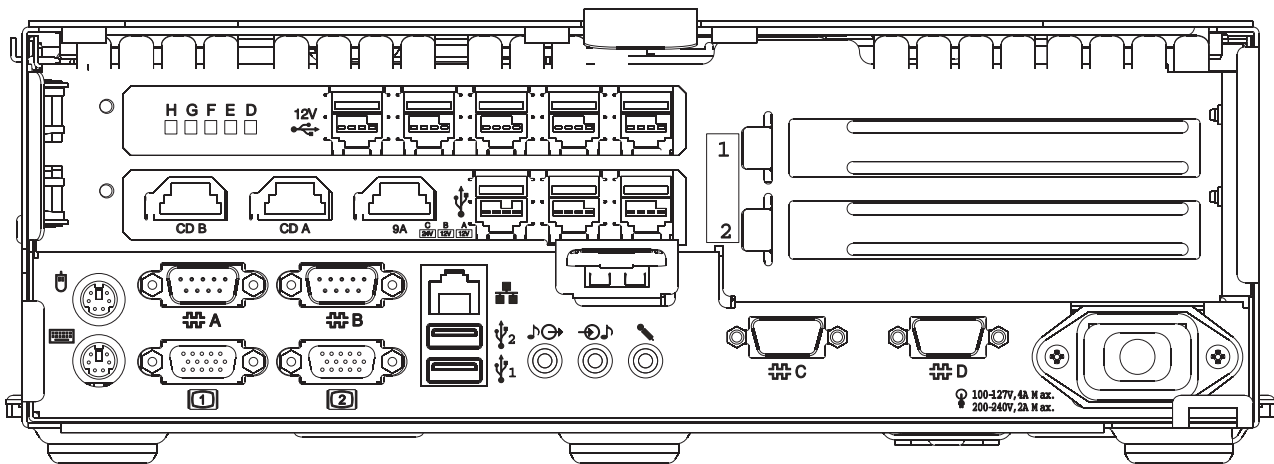











Figure 4. Rear panel

Table 4. Connection icons definitions

| Icon   | Definition      | Icon   | Definition  |
|--|-----------------|--|---|
|   | PS/2 mouse      |     | Display 1 and 2   |
|   | PS/2 keyboard   |   | Ethernet LAN  |
| <br> | USB 2.0         |   | External serial devices (such as a scale and a scanner) A and B (and C and D on Models 743, C43, E43, 783, and E83) |
|   | Line (audio) in |  | Line (audio) out  |
|   | Microphone      |  |   |

## IBM SurePorts Point-of-Sale connections

There are several possible configurations of IBM SurePorts in a SurePOS 700. This section details some of the most common.

**Attention:** Hot plugging of powered USB devices is not supported.

**Attention:** RS-485 Port 7 and Powered USB 24V port are intended for use with POS printers (IBM SureMark™ 4610). All IBM POS printer cables are classified as UL Data-Processing Cables DP-3. For safe use of these ports, any third party cables must meet the same requirements.

### Base configuration

Figure 5 shows the base SurePort adapter configuration (the top slot is filled by a blank).

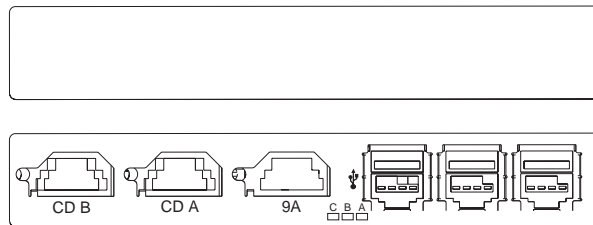

Figure 5. Base configuration

**A, B** 12 V powered USB ports

**C** 24 V powered USB port

**CD A (3A), CD B (3B)**

IBM cash drawer ports

**Note:** Port 3A automatically detects an IBM cash drawer. If you use non-IBM cash drawers, read the voltage considerations described in “Cash drawers” on page 17.

**9A** RS-485 scanner or a secondary RS-485 display

### RS-232 and base configuration

Figure 6 shows the RS-232 SurePort adapter with the base SurePort adapter configuration.

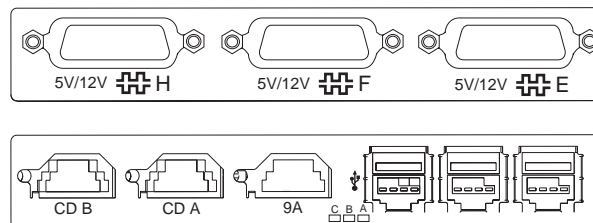

Figure 6. RS-232 and base configuration

**A, B** 12 V powered USB ports

**C** 24 V powered USB port

**CD A (3A), CD B (3B)**

IBM cash drawer ports

**Note:** Port 3A automatically detects an IBM cash drawer. If you use non-IBM cash drawers, read the voltage considerations described in “Cash drawers” on page 17.

**E, F, H**

Powered RS-232 (serial) ports

**9A** RS-485 scanner or a secondary RS-485 display

**Serial I/O (SIO) and base configuration**

Figure 7 shows the RS-485 SurePort adapter with the base SurePort adapter configuration.

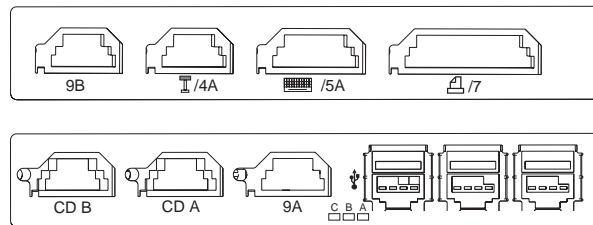

Figure 7. RS-485 and base configuration

**A, B** 12 V powered USB ports

**C** 24 V powered USB port

**CD A (3A), CD B (3B)**

IBM cash drawer ports

**Note:** Port 3A automatically detects an IBM cash drawer. If you use non-IBM cash drawers, read the voltage considerations described in “Cash drawers” on page 17.

**4A** IBM RS-485 primary display

**5A** IBM RS-485 primary POS keyboard

**7** RS-485 printer port

**Notes:**

1. The RS-485 back panel has hardware jumpers that can be changed to provide either 24 V or 38 V to the printer connector. The factory default is 38 V.
2. For systems with both 24 V and 38 V printer ports, only *one* printer (either USB or RS-485) can be connected at the same time.

**9A, 9B**

RS-485 scanner or a secondary RS-485 display

## USB and base configuration

Figure 8 shows the USB SurePort adapter with the base SurePort adapter configuration.

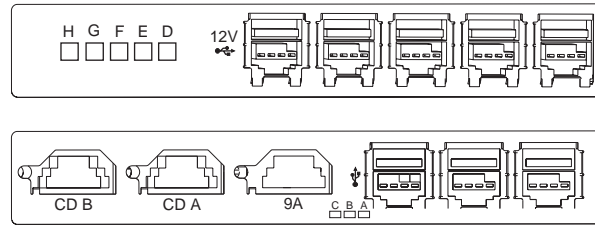

Figure 8. USB and base configuration

### A, B, D, E, F, G, H

12 V powered USB ports

**Note:** The letters shown on the USB connectors are used to identify the connector space and the order of connection per card. As an example, for each card, the system first recognizes a device connected to USB port A before recognizing the device connected to USB port B. This autosensing feature applies to both cards; therefore, the system could recognize card 1, USB port B, then C, before recognizing the USB port D on card 2.

**C** 24 V powered USB port

### CD A (3A), CD B (3B)

IBM cash drawer ports

**Note:** Port 3A automatically detects an IBM cash drawer. If you use non-IBM cash drawers, read the voltage considerations described in “Cash drawers” on page 17.

**9A** RS-485 scanner or a secondary RS-485 display

## Cooling

Cooling is provided through forced-air cooling by a fan contained in the power supply and, in some cases, by a chassis fan. Air vents must not be blocked, and the vents must have two inches of clearance from cabinet walls, trash cans, and papers.

## Environmental and temperature

These environmental characteristics apply:

- Operating temperature: +10 to 40°C (+50 to 104°F) with 8% to 80% relative humidity
- Shipping: -40 to +60°C (-40 to +140°F)
- Storage: 0 to +60°C (32 to +140°F)

## Power

This section describes the power, power switches, and power management.

**Attention:** Hot plugging of powered USB devices is not supported.

These are the power requirements for the SurePOS 700 Series Models 723, E23, 743, C43, E43, 783, and E83:

- Input voltage: 100 to 127 VAC or 200 to 240 VAC nominal
- Frequency: 50 to 60 Hz,  $\pm 3$  Hz
- Power consumption: 70 W typical, 120 W maximum

See Table 5 for the maximum continuous DC load rating for each port.

*Table 5. Port DC loads.*

**Notes:**

1. The total 12 V current for all external loads is 5 A maximum. The total 5 V current available for all external loads is 5 A maximum.
2. Two printers cannot be attached to the system simultaneously.
3. Only one cash drawer can be activated at any time.

| Port  | Amperage           |
|---|--------------------|
| 24 V printer  | 3.0 A              |
| 38 V printer  | 2.1 A              |
| 24 V/38 V cash drawer   | 1.0 A 150 ms pulse |
| 12 V RS-485   | 1.0 A/port         |
| 12 V RS-232   | 1.0 A/port         |
| 12 V USB  | 1.5 A/port         |
| 5 V RS-485  | 1.0 A/port         |
| 5 V RS-232  | 1.0 A/port         |
| 5 V PS/2 keyboard   | 0.5 A/port         |
| 5 V PS/2 mouse  | 0.5 A/port         |
| 5 V in all USB ports  | 0.5 A/port         |
| <b><i>The total 12 V current for all external loads is 5 A maximum.</i></b> |                    |
| <b><i>The total 5 V current for all external loads is 5 A maximum.</i></b>  |                    |

## Power switch operation

During normal operation, the power switch on the SurePOS 700 Series operates as you would expect. Push the switch to turn the system on; push it again to turn the system off. There are some exceptions:

1. You can program the switch to operate differently. For example, if your operating system supports power management, you can program the switch to behave as a standby or resume switch. For more information, refer to the documentation included with your operating system or power management software.
2. A delay can occur when you are turning the system off, if you press the power button when the unit is running its power-on self-test (POST).
3. Sometimes you cannot initiate a controlled shutdown because the application or system is hung. Press and hold the power switch until the unit turns off (approximately five seconds).

**Note:** This is not the recommended method of turning off the SurePOS 700. Use it only when no other method is available to turn off the system. If you turn off the unit by pressing and holding the power switch, some programmed events do not function until the unit is turned on again (for example, IBM Wake on LAN).

## Power management

Power management on the SurePOS 700 is based on the standard desktop PC model. Depending on the OS and drivers that are used, all models are capable of being placed into a standby state with AC power applied. Protection from AC power events is provided by an optional UPS that can be integrated into the wide-footprint unit. Support is provided for the following industry standards and conventions:

- Advanced Configuration and Power Interface-Advanced Power Management (ACPI-APM)
- IBM Wake on LAN
- Wake on USB
- Wake on SIO
- Wake on PS/2 keyboard/mouse
- Wake on real-time clock alarm

## Uninterruptible power supply (optional)

The technical characteristics of the uninterruptible power supply are as follows:

- Capacity: 500 VA/300 W
- Run time: 2.5 minutes minimum at full-rated (500 VA) load with a new, fully charged battery
- Output voltage in battery mode: 113 VAC  $\pm$ 10% for low range; 220 VAC  $\pm$ 10% for high range
- Frequency (in backup mode): 60 Hz  $\pm$ 3 Hz for line frequency > 55 Hz; 50 Hz  $\pm$ 3 Hz for line frequency < 55 Hz (output waveform is a stepped sine wave approximation)
- Transfer time: less than 8 ms typical, 10 ms maximum, AC to battery

The characteristics of the batteries are as follows:

- The battery is replaceable by persons with typical PC hardware upgrade skills.
- Battery recharge time is typically 8 hours, with a maximum of 16 hours for a fully depleted battery.
- Battery type is a 12 V, 5 AH, sealed, leakproof, maintenance-free lead-acid type.

### Battery life

With a new, fully charged battery, the UPS is capable of delivering full output for 2.5 minutes. Typical POS configurations require much less power. A typical system unit with an liquid crystal display (LCD) operator display can last 15 minutes with a new, fully charged battery, depending on print activity; and it can last 60 minutes if the terminal is in standby mode. The battery charge capacity decreases over time and this decrease is accelerated by heavy usage. Regular deep discharges of the battery can dramatically reduce its useful service life. The useful life of a battery in a typical environment is one to three years.

### Input voltage

The UPS option cannot sense low- versus high-line voltages. Separate units are designed for low- and high-line voltages, which cannot be converted between high- and low-line voltage. Figure 9 on page 15 shows the power outlets and connectors of the UPS.

**Attention:** Damage to the UPS will occur if incorrect line voltage is applied to the unit.

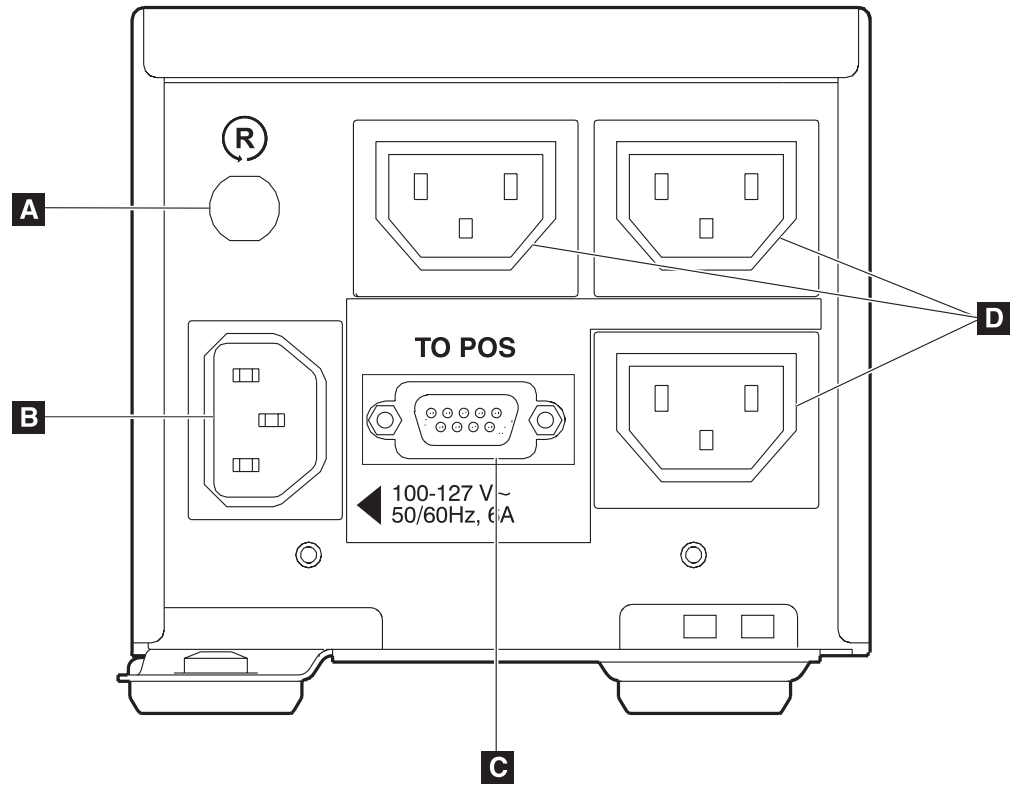

Figure 9. UPS rear view

- A** Circuit breaker
- B** Power inlet
- C** RS-232 port
- D** AC outlets

### System unit interface

The UPS has an RS-232-compatible output that can connect to one of the system unit RS-232 ports to communicate UPS status (AC power loss, low battery) to the operating system or application. The interface is compatible with the Microsoft Windows default UPS implementations.

## Configuration switches

The UPS configuration dual in-line package (DIP) switches are located on the front panel of the UPS subassembly (see **A** in Figure 10). Use these switches to select whether the ON or OFF state of the connected system unit controls the operation of the UPS during an AC power outage.

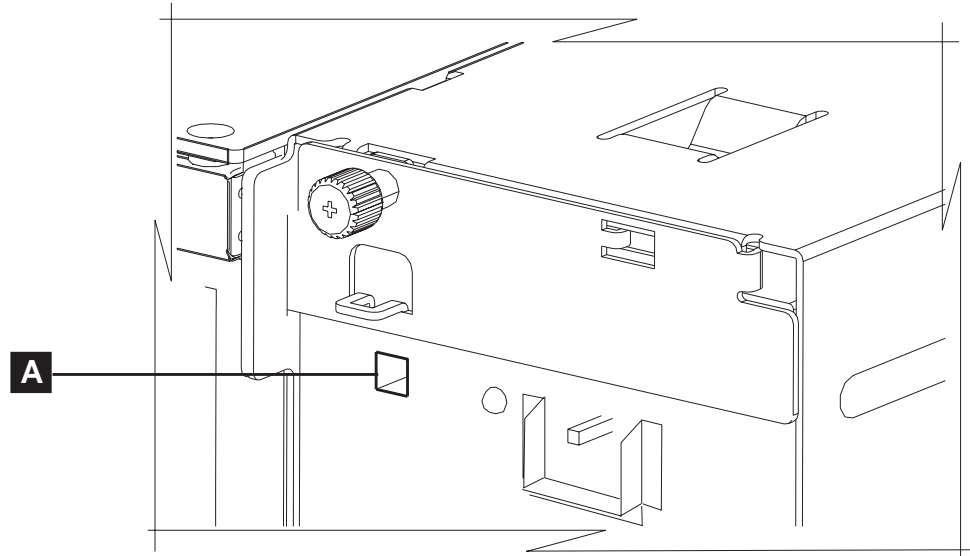

Figure 10. Location of UPS configuration switches

**Stand-alone mode:** When both switches are set to the OFF, or up, position (factory default), the UPS always enters battery mode during an AC outage. The unit remains in battery mode until AC is restored or until the battery is discharged. *On-battery* and *low-battery* signals are available to the associated system when an RS-232 cable connection is in place, but there is no control of the UPS from the system unit. This mode of operation is typical for the *standby* type of power supplies commonly found in the marketplace.

**Host-dependent mode:** The host-dependent mode is when both DIP switches are set in the ON, or down, position. During an AC outage, the UPS does not remain in battery mode for more than five seconds unless there is an active RS-232 connection present from a powered-on system unit. If the system unit is turned on, the UPS remains in standby mode. If the system unit is turned off, the unit does not stay in standby mode. When AC power is restored, AC power is again available at the UPS output. This setting is useful for situations where system units are turned off at the close of business and the main store power is also shut down. This setting prevents the UPS from switching into standby mode and discharging the battery when the store power is removed.

---

## I/O devices

The SurePOS 700 Models 723, E23, 743, C43, E43, 783, and E83 support a wide range of displays, keyboards, printers, cash drawers, and scanners. Refer to the IBM Retail Store Solutions Web site at <http://www.ibm.com/solutions/retail/store/support> for a list of currently supported devices.

**Note:** Additional I/O installation and operation information is available in these publications:

- *Point-of-Sale Options and I/O Devices Service Guide, GC30-9737*

- *Store Systems Installation and Operation Guide for Point-of-Sale Input/Output Devices, GA27-4028*

## Cash drawers

The SurePOS 700 Models 723, E23, 743, C43, E43, 783, and E83 are preconfigured from the factory to work correctly with all IBM cash drawers. In this automatic mode, the system can correctly detect the difference between IBM 24 V and IBM 38 V cash drawers. Cash drawer port 3A provides an autosensing function for an IBM cash drawer.

### CAUTION:

**Automatic mode sets the cash drawer operating voltage for both cash drawer ports. If you connect a 24 V cash drawer to port 3A and then connect a second drawer, it must also be a 24 V drawer. If you are using a non-IBM drawer, the automatic mode will not work correctly; and damage to either the cash drawer, the system unit, or both is possible. If you have two connected cash drawers, both drawers must be the same voltage.**

You can configure the cash drawer voltage (24 V or 38 V) with the configuration options in the POS configuration setup program or with the jumper override. Figure 11 shows the location of the cash drawer voltage jumper on the riser card and a diagram with the position of the jumpers.

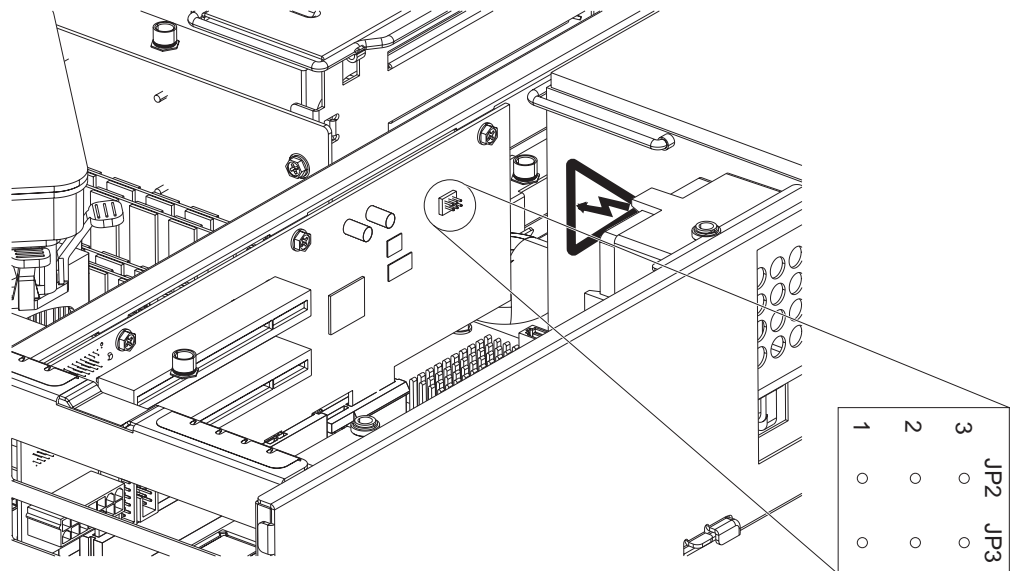

Figure 11. Setting the cash drawer using the jumper override

Table 6 provides the correct jumper settings for the 24 V and 38 V cash drawers.

Table 6. Cash drawer jumper settings

| Voltage                   | Jumper JP2 | Jumper JP3 |
|---------------------------|------------|------------|
| Automatic setup (default) | Not used   | 2-3        |
| Manual 38 V               | 1-2        | 1-2        |
| Manual 24 V               | 2-3        | 1-2        |

## Voltage setting for the 4689 DBCS SurePOS Receipt Journal printer

To operate correctly with the SurePOS 700 Models 723, E23, 743, C43, E43, 783, and E83, the 4689 double-byte character set (DBCS) SurePOS Receipt Journal printer voltage must set to 24 V. All other RS-485 printers will work correctly with the SurePOS 700 at the default setting of 38 V.

To configure the printer voltage to 24 V, set jumpers JP1 and JP2 as shown in Table 7.

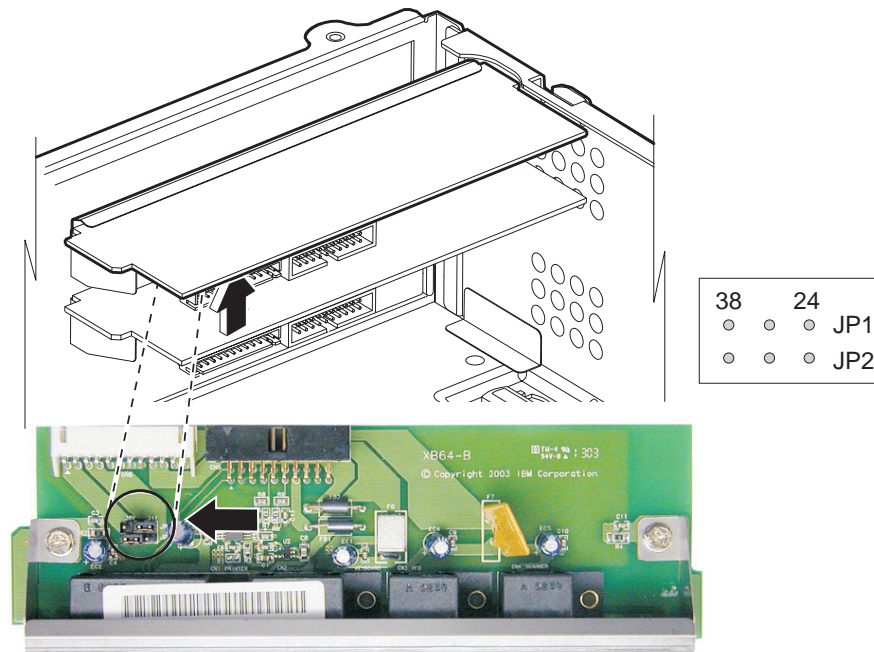

Figure 12. Location of the printer jumper on the I/O card

Table 7 provides the correct jumper settings for 24 V and 38 V printers.

Table 7. Cash drawer jumper settings

| Voltage               | Jumper JP1 | Jumper JP2 |
|-----------------------|------------|------------|
| Manual 38 V (default) | 1-2        | 1-2        |
| Manual 24 V           | 2-3        | 2-3        |

## Powered USB connectors

The powered USB connectors provide additional power from the host to devices that require more power than is available from the USB standard Type A connector. As shown in Figure 13 on page 19, the powered USB receptacle consists of two connectors that are integrated within a common shielded housing. These two connectors are stacked vertically inside the common housing. The *upper connector* ( **A** in Figure 13 on page 19) contains four contacts that are used for powering the attached device. The *lower connector* ( **B** in Figure 13 on page 19) is a fully compliant USB Type A connector capable of mating with either a standard USB Type A plug or a powered USB plug. In other words, the bottom half of the connectors are standard USB Type A ports to which USB I/O devices can be attached.

**Note:** On SurePort cards, the connector is mounted upside down; on the front USB port, the connector is mounted sideways.

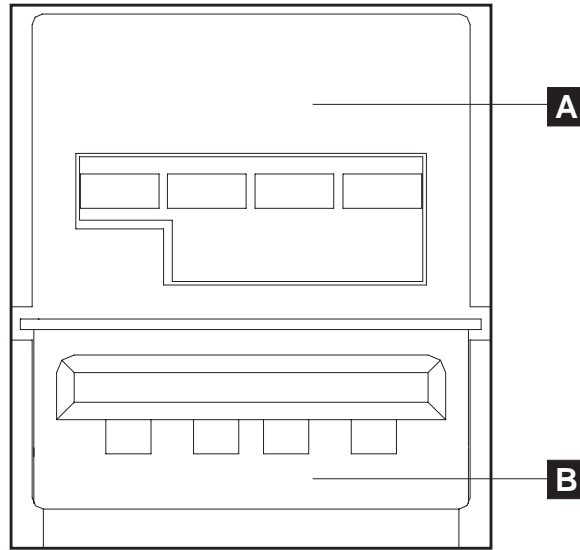

Figure 13. Example of the powered USB port

- A** Upper connector; power section of the connector
- B** Lower connector; standard USB section of the connector

Powered USB connectors provide these features:

- Additional power for USB POS I/O devices needing more than 5 V
- Unique keying and color coding of the 12 V and 24 V connectors, which prevents unintentionally attaching a connector to the wrong type of port
- Positive mechanical retention latch between the plug and receptacle, which prevents inadvertent disconnections

### Non-POS I/O devices

The SurePOS 700 Models 723, E23, 743, C43, E43, 783, and E83 support most of these non-POS I/O devices:

- Many, but not all, USB mass-storage devices such as diskette drives, CD-ROM drives, and memory keys. Lack of standardization precludes a list of the devices that are not supported. Boot mode is supported for most devices that support USB boot.
- IBM VGA monitors (CRT and LCD)
- Industry-standard PC keyboards, mice, and printers
- Standard USB and RS-232 devices with appropriate drivers, software, and operating systems

---

## System and driver support

This section describes the supported operating systems, BIOS information, and driver requirements for the SurePOS 700 Models 723, E23, 743, C43, E43, 783, and E83.

### Operating systems

These operating systems are supported:

- 4690 OS Version 5 Release 2 (V5R2) or higher
- Windows 2000 with Service Pack 4
- Windows XP Professional Edition with Service Pack 2
- Windows XP Embedded for Point of Service (WEPOS) V1.1 or higher
- PC DOS 2000

**Note:** Problem resolution procedures typically require the installation of the latest fix pack.

### Drivers

Driver packages are available on the IBM Web site at <http://www.ibm.com/solutions/retail/store/support> for download for all supported operating systems. A complete list is provided on the Web site. Drivers are provided for video, LAN, USB, audio, RS-232 (if required), and POS I/O. In many cases, the default drivers shipped with the operating system will be satisfactory.

### BIOS

The SurePOS 700 Series has an upgradeable BIOS. IBM provides utilities to upgrade the BIOS and updates are published on the support Web site. You are responsible to perform BIOS upgrades as required. BIOS upgrades are not covered by IBM warranties or maintenance agreements.

---

## Compatibility

To ensure that the SurePOS 700 Models 723, E23, 743, C43, E43, 783, and E83 operate smoothly with any previous hardware equipment and software programs, carefully review the requirements in this section.

### Hardware

- **All cash drawers:** If you use non-IBM cash drawers, you must use the POS I/O configuration screen or jumper override to set the correct operating voltage. Failure to do so can damage the cash drawer or the system unit. See "Cash drawers" on page 17.
- **4820 DVI displays:** These displays require a video card that supports Digital Video Interactive (DVI). The output port is installed in the feature card slot.
- **4820 displays with the integrated speaker feature:** These displays require a PCI audio card with integrated speaker amplification.
- **4820 "active" microphone:** The microphone in these displays does not work with the system.
- **PCI Express x1 or PCI card slot:** The maximum length of PCI Express or PCI card slots is 195 mm (7.6 in.).

## Software

This section provides details about operating system software requirements and considerations.

**Note:** New and unique drivers for all operating systems are required for all functions in the product.

### General migration considerations

These are common migration considerations in retail environments:

- If it is installed, the IBM 4690 OS must be V5R2.
- Applications with hardcoded routines to specific interrupt request (IRQ) levels or I/O addresses might experience migration problems.
- Applications requiring COM ports 3 or greater must be capable of using a PCI-compliant, Plug and Play device that uses the shared interrupt architecture.
- Third-party memory modules do not work with every product.

### DOS migration considerations

New LAN drivers are required, with modifications to LAN configuration files such as PROTOCOL.INI. Modifications to CONFIG.SYS and AUTOEXEC.BAT are also required.

### Windows and Linux migration considerations

To migrate a Windows or Linux environment, first reinstall the operating system.

After the operating system is installed, install the appropriate drivers (downloaded from the IBM Retail Store Solutions Web site at <http://www.ibm.com/solutions/retail/store/support>), and then install the applications.

**Note:** Existing operating system images for the 4694 or previous models of 4800 are not compatible with the SurePOS 700 Models 723, E23, 743, C43, E43, 783, and E83. However, after you install the operating system, typical HDD imaging utilities should operate correctly.

### RAID

The Redundant Array of Independent Disks (RAID) function provides support for redundant hard disk drives. Supported only on the Microsoft Windows operating systems, RAID provides an error message if one of the two hard disk drives experiences a failure. For more information, see the *SurePOS 700-722/742/782, 723/743/783 Operating System Installation Guide, GA27-4357*.

## Preparing to call for service

When you call IBM for warranty information or service, be sure to have the serial number, machine type, and model number available.

Figure 14 shows the location of this information on the pullout tray of SurePOS 700 Models 723, E23, 743, C43, E43, 783, and E83.

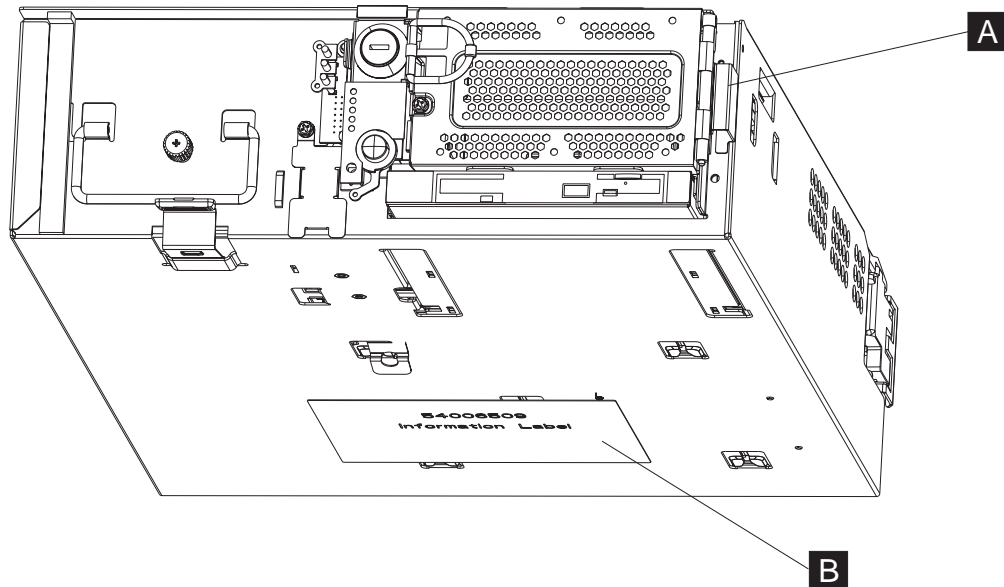

Figure 14. Serial number and machine information on front and bottom

**Note:** Both positions **A** and **B** show the serial number, machine type, and model number.

You can also obtain this information from the BIOS setup screen, as follows:

1. With a monitor and keyboard attached, turn on the system.
2. Press the **Delete** key during POST, to enter BIOS setup.
3. Use the arrow keys to navigate to **Standard CMOS Features** and press **Enter**. The machine type, model, and serial number are shown, in addition to other unit-specific information.

---

## Chapter 2. Installing and setting up the system

This section describes the steps to install and setup your SurePOS 700 Models 723, E23, 743, C43, E43, 783, and E83.

---

### Before you begin

Read this information before you begin your installation.

### Supported operating systems

See “Operating systems” on page 20 for a list of supported operating systems.

### Determining your configuration

You can set up your system units in either an integrated or distributed configuration. An *integrated* configuration is one in which all parts of a system are assembled in one location. A *distributed* configuration is one in which you set up parts of the system in different physical locations. In an integrated configuration, you can use the slanted I/O tray option for the wide units to contain peripheral devices, such as printers and displays, on top of wide-footprint system units. There are also slanted I/O tray options that you can mount on the full-size cash drawer or directly on the counter.

### Your order and packaging

Each order includes the following components:

- System unit
- LAN patch cable: 4.2 m (14 ft), Category 6
- Country-specific power cord
- Cover kit
- Factory installed options, such as direct-access storage devices (DASDs) or extra memory
- Safety manual
- Customer-installed options

**Note:** All publications are also available from the IBM Retail Store Solutions Web site at <http://www.ibm.com/solutions/retail/store>.

---

### Setup procedures

To install the SurePOS 700, follow the steps in this section.

**Note:** Before installing, be sure to read “Federal Communications Commission (FCC) statement” on page 109.

### (Optional) Replacing the front lock plug with a lock

The SurePOS 700 Models 723, E23, 743, C43, E43, 783, and E83 ship with a non-locking plug in place of the front lock. To replace the plug with a front lock insert:

1. Rotate the plug to the fully open (unlocked, left) position (see Figure 15 on page 24).



Figure 15. Front lock plug in fully open position

2. Take a firm grip of the plug (using pliers or similar tool) and insert a screwdriver into the top slot on the lock cylinder, to disengage the plug tab ( **A** in Figure 16). Pull the plug to remove it.



Figure 16. Removing the front lock plug

3. Follow the steps in “Installing and removing lock inserts” on page 72, to install the front door lock insert.

## Step 1. Installing your internal options

After you unpack and review your packing slip, install your internal options. Chapter 3, “Installing internal options,” on page 43 provides instructions for installing these features.

## Step 2. Installing the expansion housing and the optional UPS (wide units only)

This procedure is for wide units only.

To install the expansion housing, with or without the optional UPS:

1. Remove the retainer bracket from the expansion housing as shown in Figure 17 on page 25.

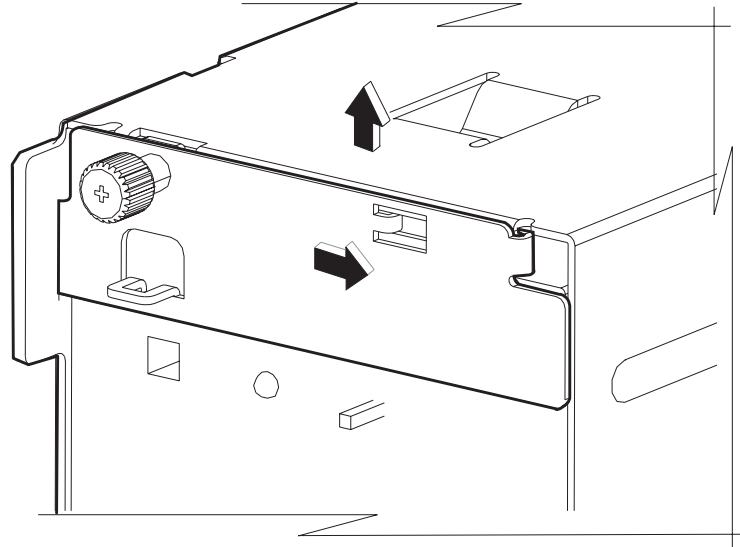

*Figure 17. Removing the retainer bracket*

- a. Turn the retaining screw to the left to unlock the bracket from the housing.
- b. Pull the bracket to the right and then lift it out, to remove it from the notches.
2. Place the unit on its left side. This position lets the unit move easily, as the rubber feet do not touch the counter.
3. Align the expansion housing with the system unit, matching the tabs on the unit with the slots on the housing.

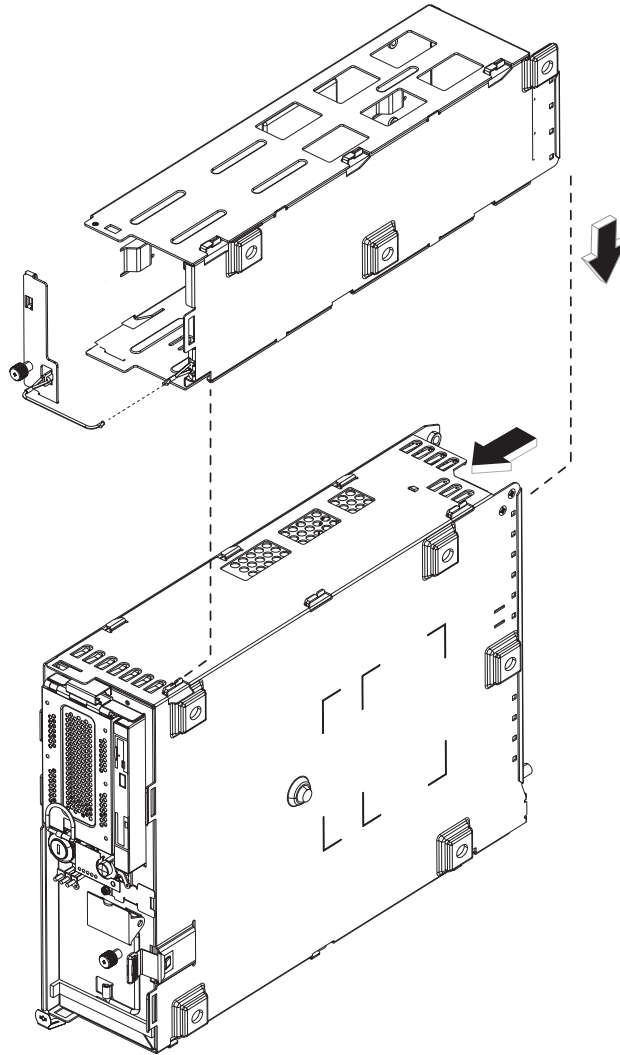

Figure 18. Aligning the expansion housing with the system unit

4. Slide the UPS forward into the expansion housing to lock it into place.  
**Attention:** Be sure the expansion housing is fully latched onto the system unit.

5. If you are *not* inserting a UPS, go to Step 6 on page 30 to secure the expansion housing to the system unit. Otherwise, complete this step to install a UPS.
  - a. Place the unit in the operating position as shown in Figure 19.

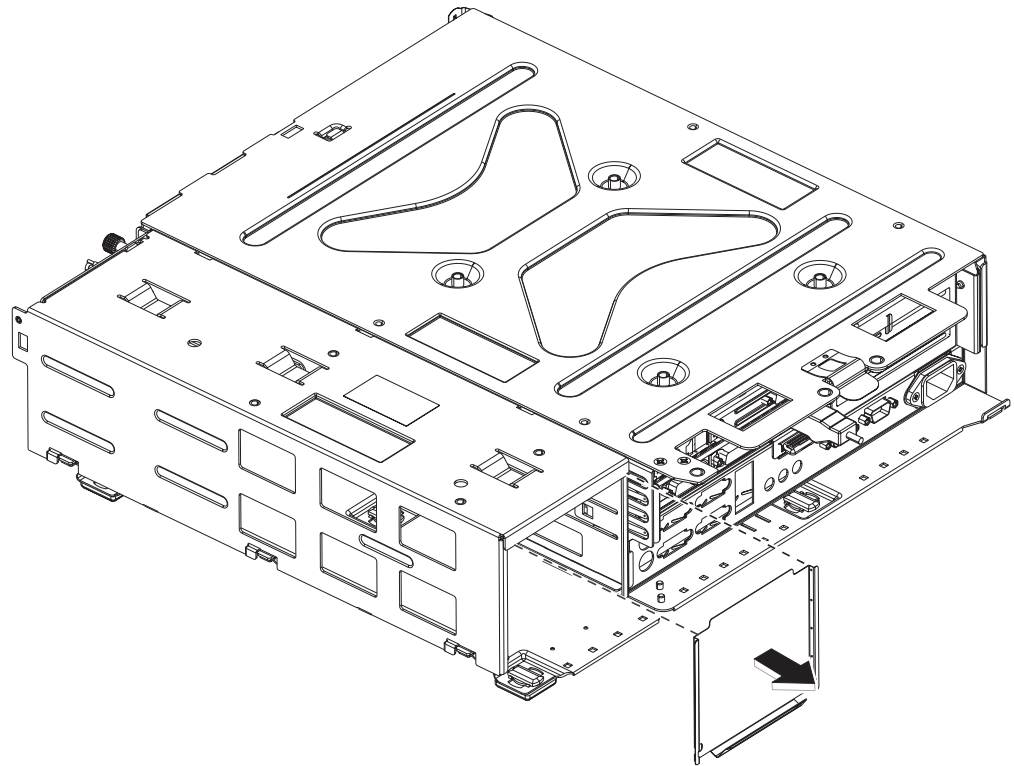

Figure 19. Removing the sheet metal panel

- b. To install the UPS, remove the sheet metal panel (see Figure 19).

- c. The unit as shipped from the factory does not have the battery connected. Connect the battery to the UPS as shown in Figure 20.

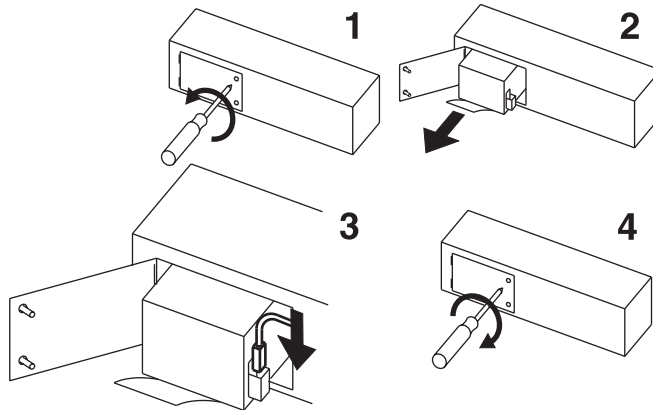

Figure 20. Connecting the battery to the UPS

- 1) With the UPS on its side, remove the battery door.
  - 2) Pull the battery out of the UPS such that you can view the wiring and plug.
  - 3) Connect the plug with the red wire.
  - 4) Push the battery back into the UPS.
  - 5) Close and tighten the screws holding the door.
- d. Peel off the battery date label and place it on the inside of the front cover assembly; **A** is the recommended location.

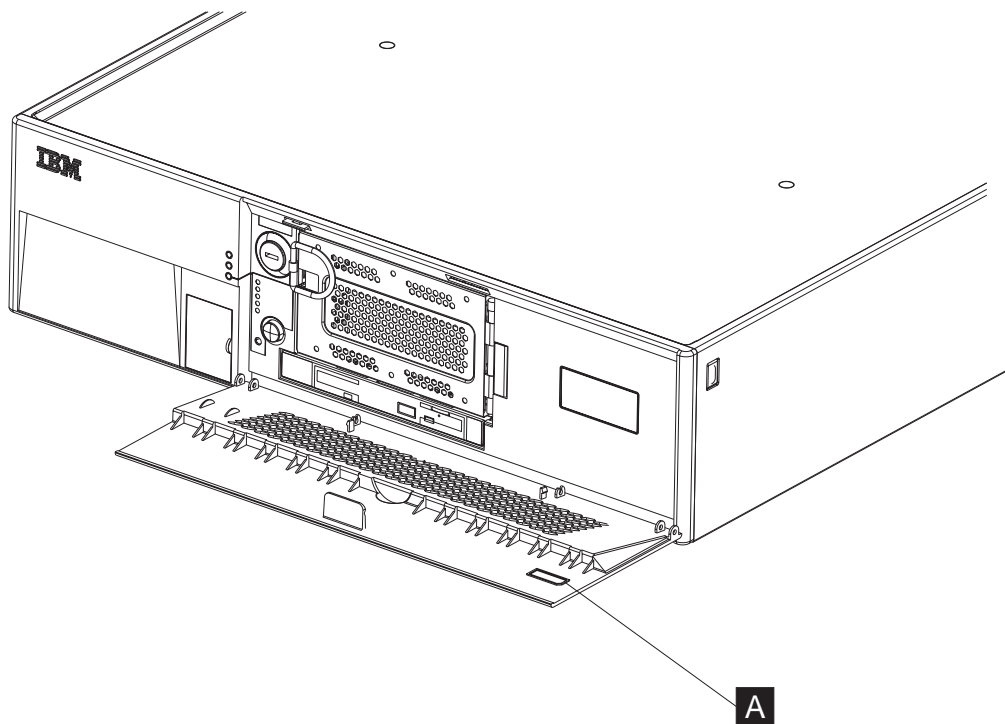

Figure 21. Saving the battery date label

- e. Insert the power supply into the housing.

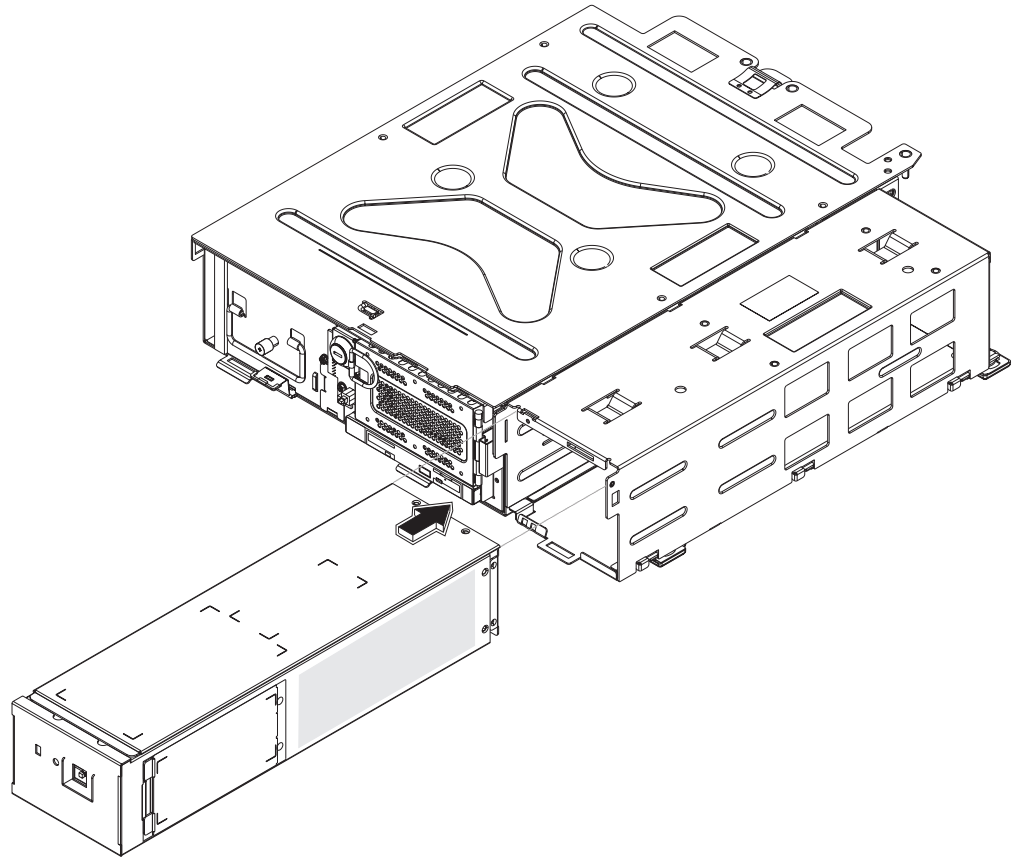

Figure 22. Inserting the UPS

6. Secure the expansion housing to the unit frame.
  - a. Insert the center tab of the retainer bracket into the notch, and then slide the retaining bracket left to engage the right hook and to insert the left tab.

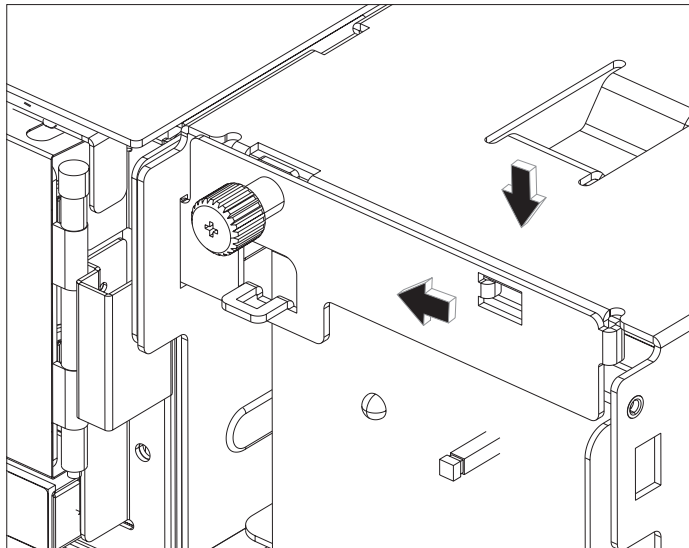

Figure 23. Replacing the UPS retainer bracket

- b. Tighten the screw.

**Note:** It helps to slightly shift the retaining bracket up and down until you feel the first threads of the screw engage.

**Attention:** The retainer bracket can only be installed if the expansion housing is fully seated and latched. For safe operation, the retainer bracket must be installed.

These steps apply only if you installed a UPS:

7. Connect the power cable to the UPS.
8. Optionally, connect the serial cable to the UPS.
9. Set the configuration (DIP) switches on the front panel of the UPS. See “Configuration switches” on page 16 for additional information.

### Step 3. Installing the covers

Cover kits provide you with a choice of color as well as a choice of width. The cover kits complete the mechanical assembly, and you should not operate the system without them.

These steps apply to all models and to both the wide and narrow features. The covers consists of these parts:

- Front bezel
- Hinged rear door
- Top cover

To install the covers:

1. Place the top cover in position over the system unit so that the front edge aligns with the line imprinted on the top plate (**A** in Figure 24), and then press the top cover sides down and inward slightly while sliding the cover forward, to lock it into place.

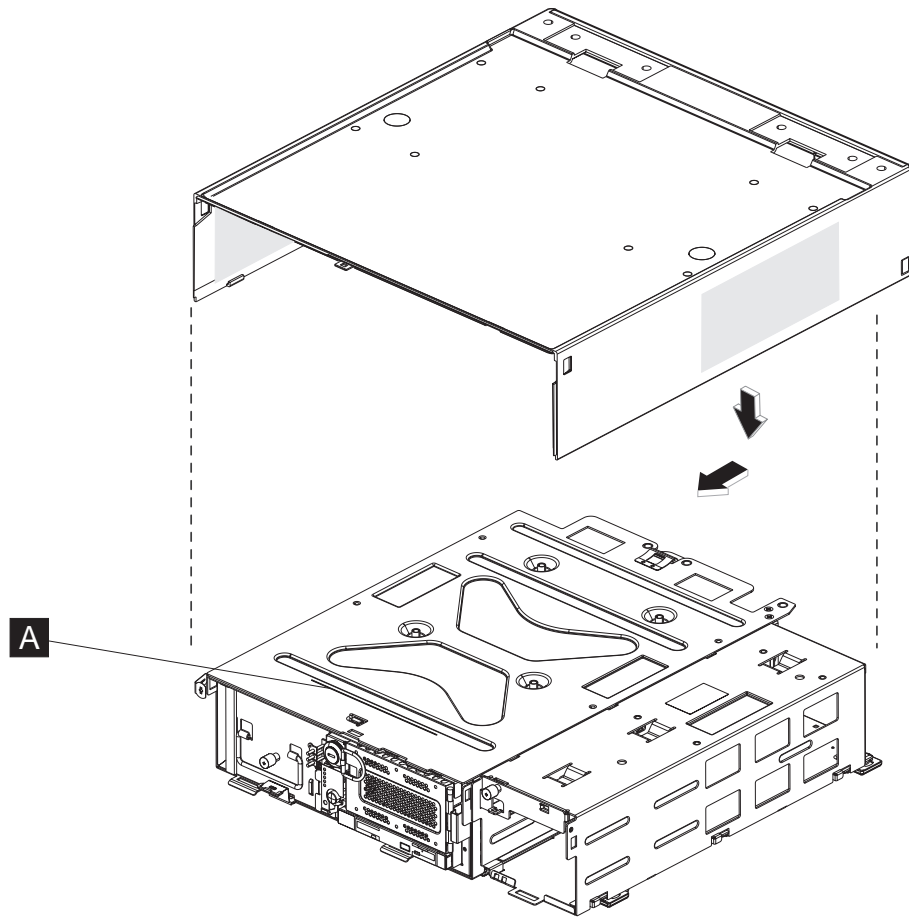

Figure 24. Installing the top cover

2. Install the rear door by holding it in a horizontal position. Insert one hinge pin (**A** in Figure 25) into the receptacle (**B**) on one side of the system unit. Press the opposite hinge pin and insert it into its receptacle from above, to snap it into place.

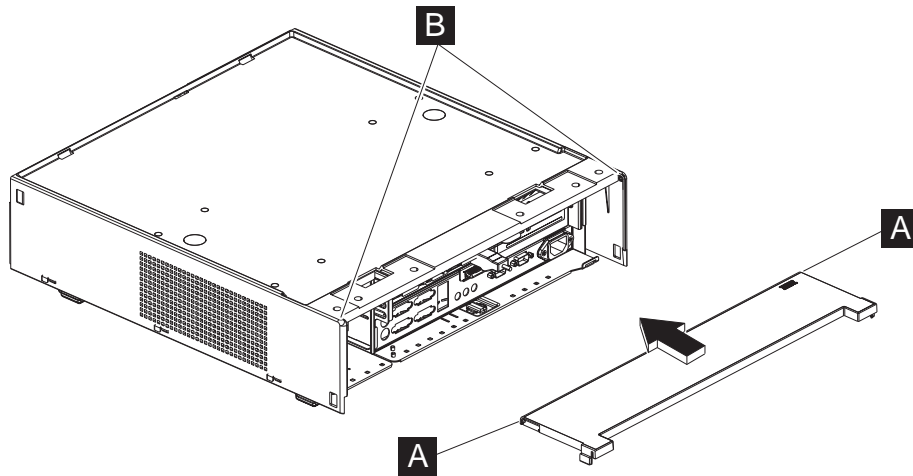

Figure 25. Installing the rear door

3. Press and insert the lower tabs (**A** in Figure 26) into the slots (**B**) to lock in place.

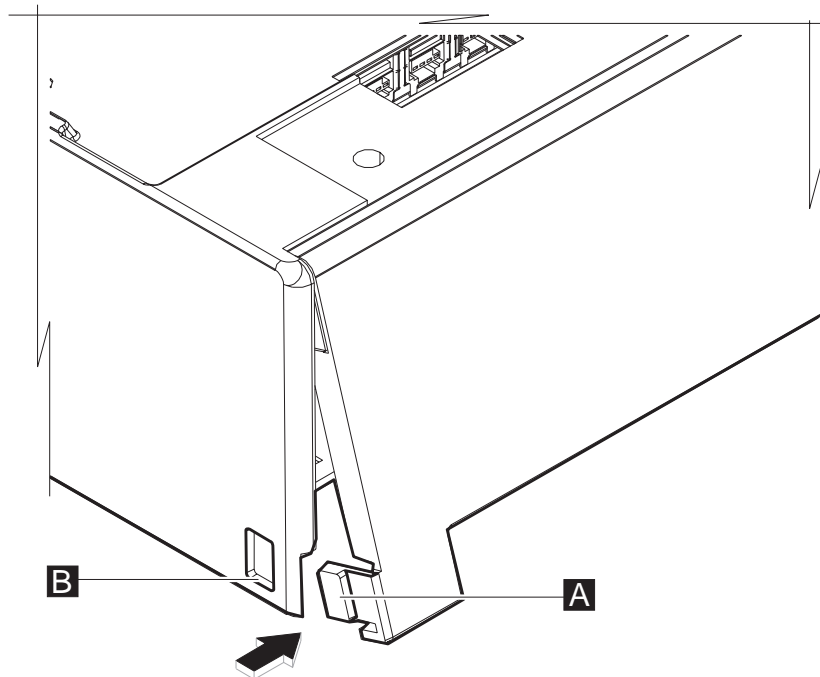

Figure 26. View of rear door lower tabs

4. If a UPS is installed in your wide unit, remove the UPS switch panel blank ( **U** in Figure 27) from the bezel.

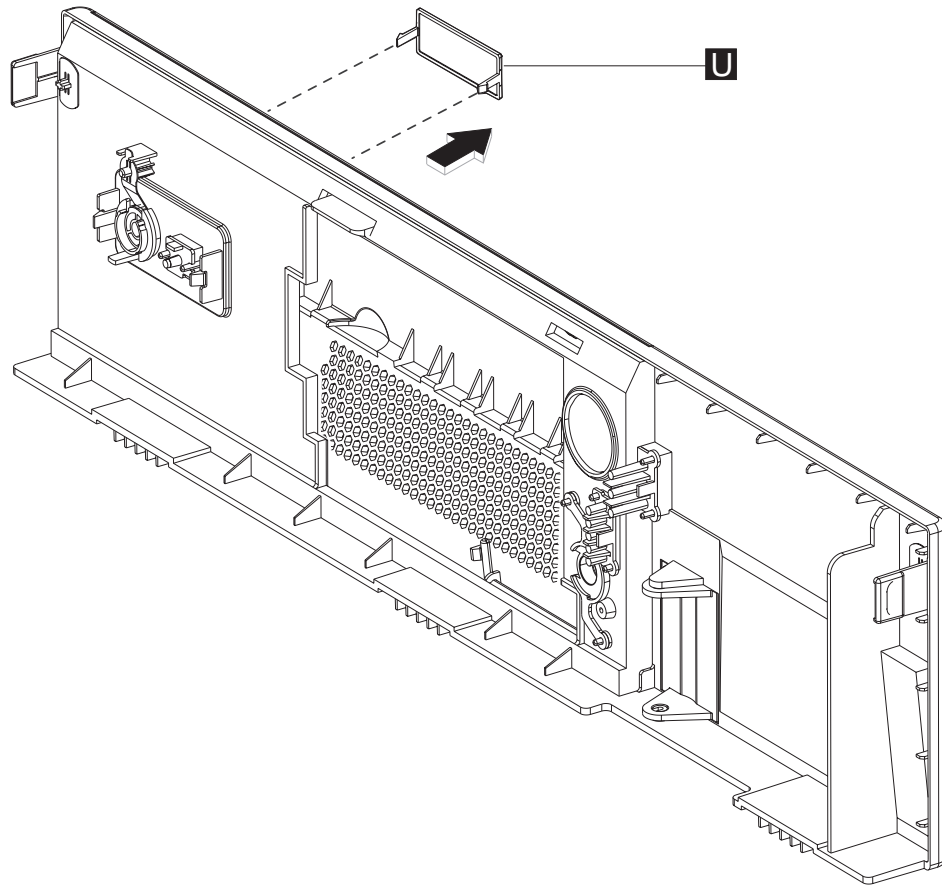

Figure 27. Removing the blank for the UPS switch panel

**Note:** Before proceeding, pivot the drive bay door D-loop handle completely to the right, flush against the front of the drive bay door, to ensure that it does not interfere with closing the front bezel.

5. Locate the hooks on the bottom of the front bezel and align these hooks with the slots on the unit frame ( **B** in Figure 28).

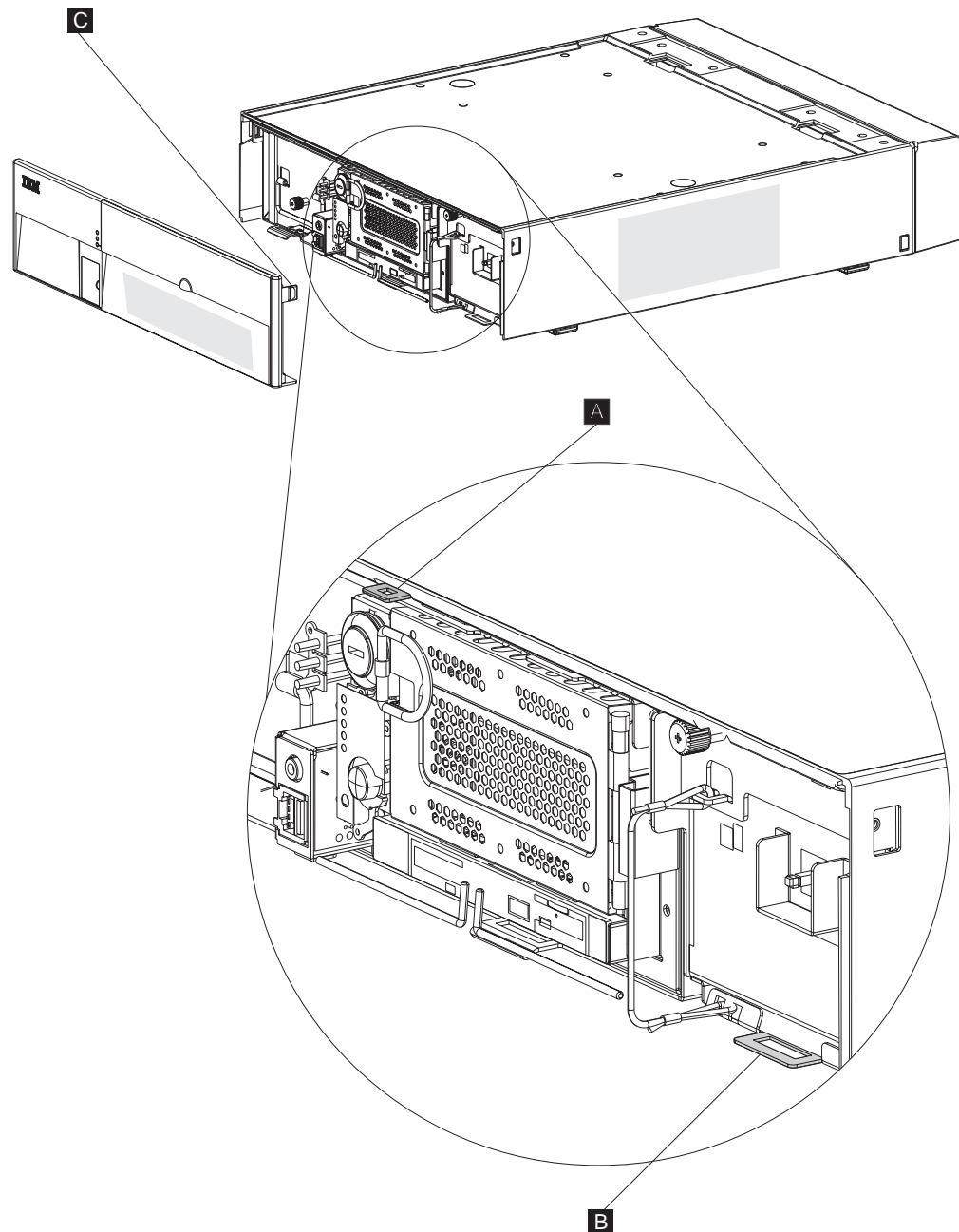

Figure 28. Placement of bezel

6. Push inward on the side tabs ( **C** in Figure 28) and insert one end and then the other into the windows on the top cover. Push gently on the bezel to close it, ensuring that the center tab locks into place ( **A** ).

### Step 3 (alternate): Installing the coverless front bezel

If you are installing the system without top covers, you may use the coverless front bezel, which hook onto the system unit frame rather than onto the top cover.

**Note:** Before proceeding, pivot the drive bay door D-loop handle completely to the right, flush against the front of the drive bay door, to ensure that it does not interfere with closing the front bezel.

To install the coverless front bezel:

1. Locate the hooks on the bottom of the coverless front bezel and align these hooks with the slots on the unit frame ( **B** in Figure 29).

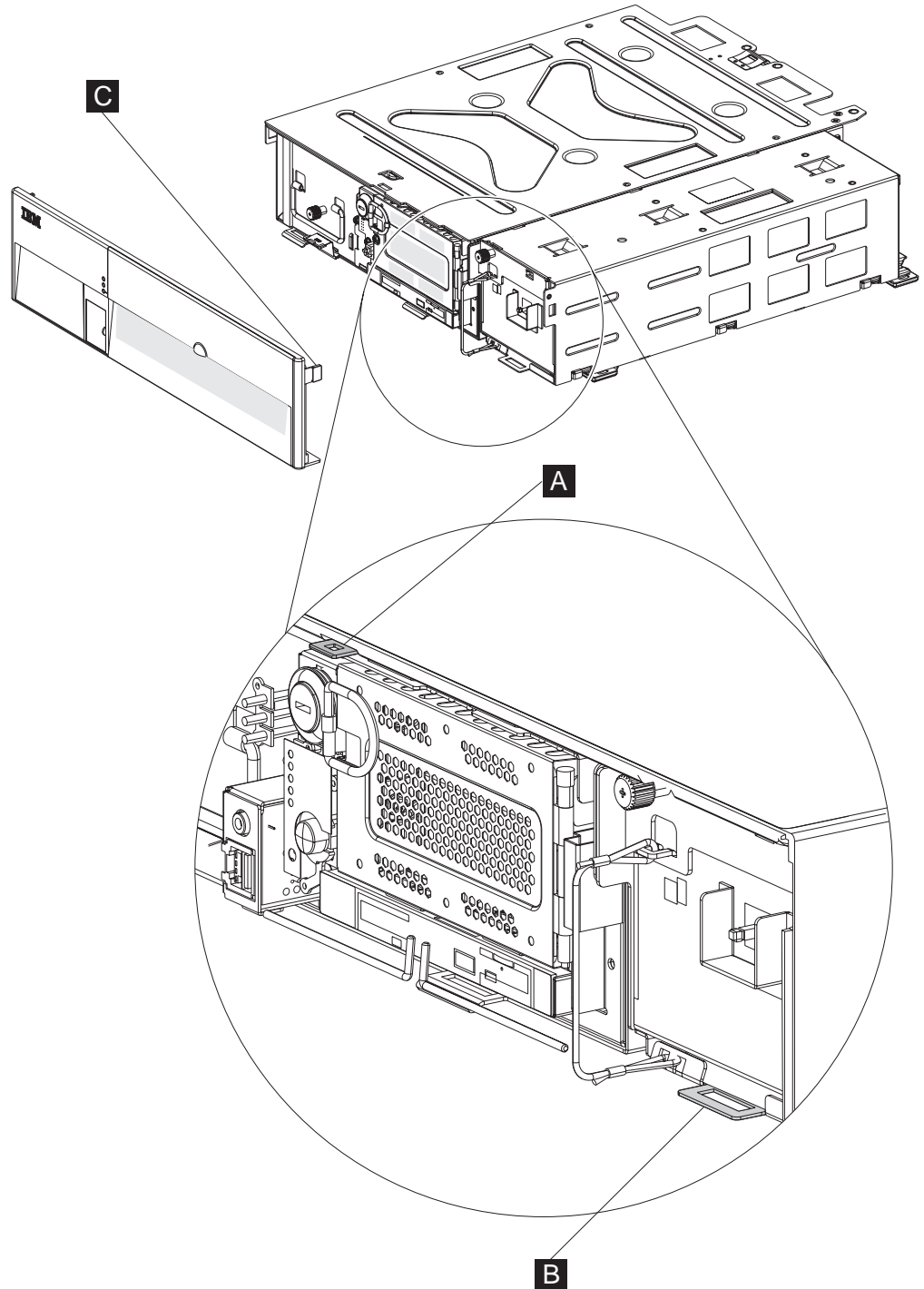

Figure 29. Placement of bezel

2. Push inward on the side tabs ( **C** in Figure 28 on page 34) and insert one end and then the other into the windows on the unit frame. Push gently on the bezel to close it, ensuring that the center tab locks into place ( **A** ).

## Step 4. Installing the slanted I/O tray (wide units only)

**Note:** This procedure is for wide units only.

Depending upon your configuration, you will need to install the slanted I/O tray:

1. Install the two mounting clips ( **A** in Figure 30) into the slanted I/O tray. From the inside of the I/O tray, insert the back of the mounting clip first and push the front part into the opening.

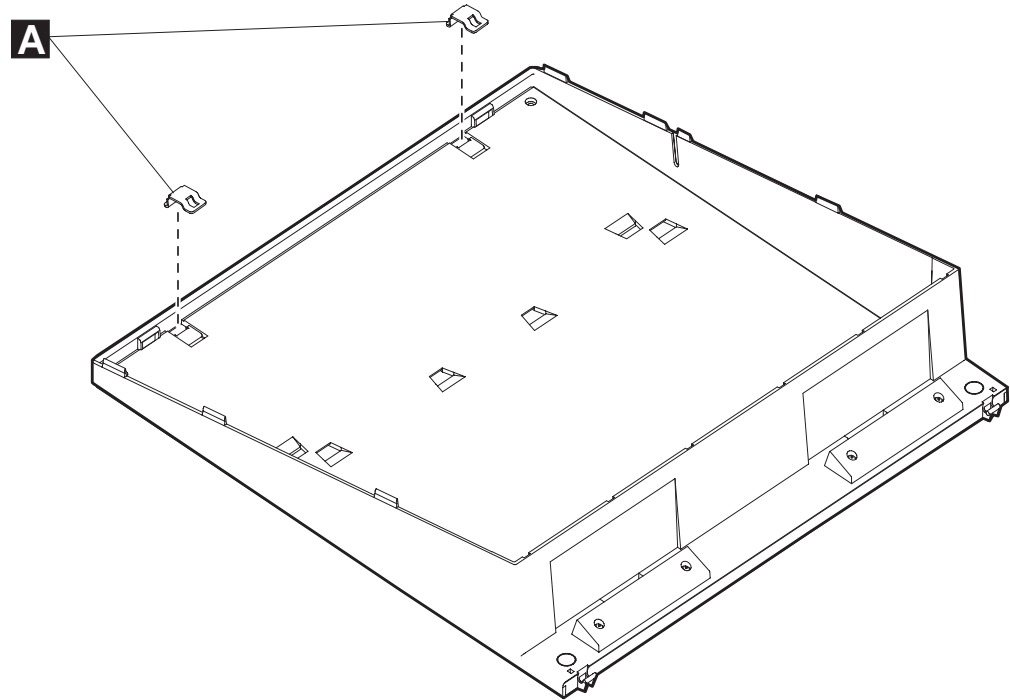

Figure 30. Installing two mounting tabs into the slanted I/O tray

2. Turn the I/O tray over. Push on the front of the tab until it clicks into place.
3. Set the I/O tray on top of the unit, and connect the tabs in front of the unit.
4. Attach the I/O tray to the cash drawer by inserting and tightening the two plastic thumbscrews into the holes at the back corners of the I/O tray.

## Step 5. Routing the cables through the slanted I/O tray

If you are setting up the unit as an integrated terminal, route the cables for the keyboard, display, or printer through the openings on the top of the unit. If you are setting up the unit as a distributed terminal, route the cables for the keyboard, display, or printer through the back of the unit.

See “Routing the cables” on page 77 for more information about cable routing through the cable guide arm assembly.

Figure 31 on page 38 shows how to route the cables through the slanted I/O tray.

**Note:** For clarity, the rear panel is simplified and the hinged rear door is not shown.

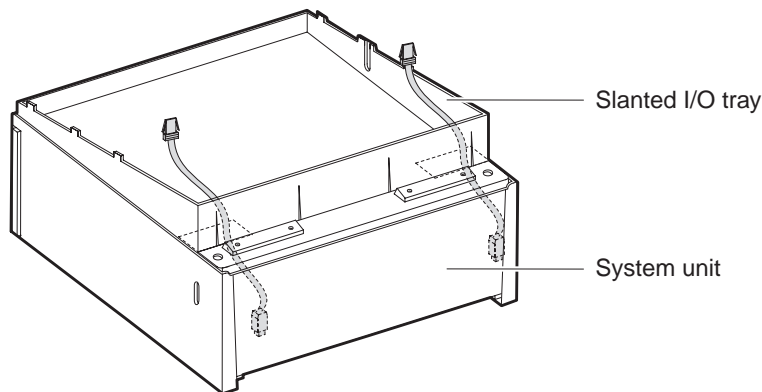

Figure 31. Routing the cables through the slanted I/O tray

## Step 6. Attaching your I/O devices

“Connectors” on page 7 identifies the SurePOS 700 Models 723, E23, 743, C43, E43, 783, and E83 connector locations for attaching your I/O devices. Chapter 4, “Installing external options,” on page 51 provides instructions on installing your I/O devices.

### Notes:

1. Install your IBM cash drawer to port 3A to use the built-in autosensing function.
2. See “Cash drawers” on page 17 for information on installing non-IBM cash drawers.
3. If you use 4689 DBCS SurePOS Receipt Journal printers, see “Voltage setting for the 4689 DBCS SurePOS Receipt Journal printer” on page 18.

## Step 7. Installing the fillers on a slanted I/O tray

### Notes:

1. Ensure that the side of each filler overlaps the tab on the side of the I/O tray.
2. If you are using an IBM 4610 SureMark printer with magnetic ink character recognition (MICR), install it on the right side. This arrangement minimizes the effect of magnetic interference from the CRT on the MICR in the printer.

Figure 32 on page 39 through Figure 35 on page 41 shows the locations of the fillers and the method for installing them. Insert the tab in the slot and push the filler toward the tab until it snaps into place.

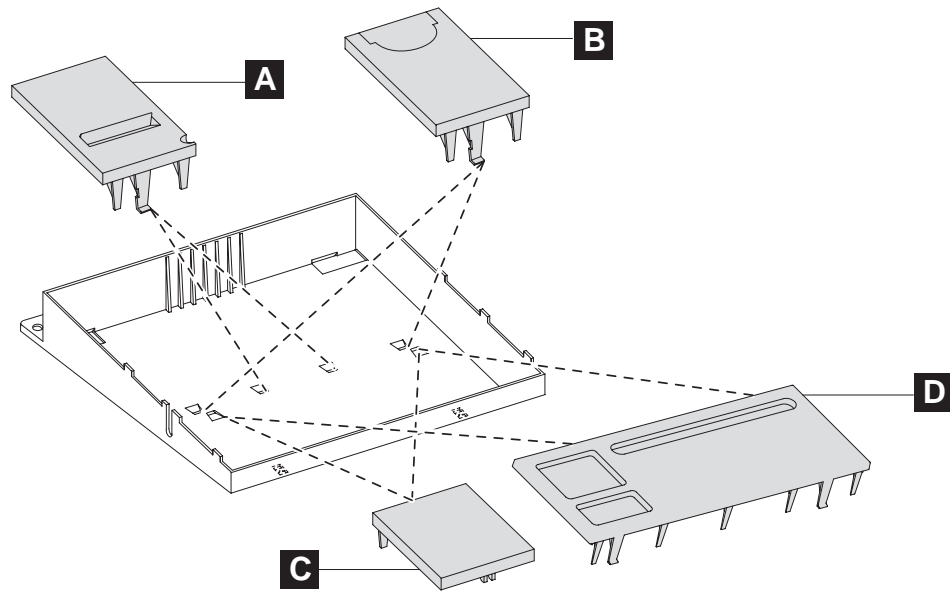

Figure 32. Mounting locations for the fillers

- A** Credit card holder
- B** Display
- C** Keyboard
- D** Keyboard replacement

**Note:** The dashed lines indicate possible locations for mounting each filler panel.

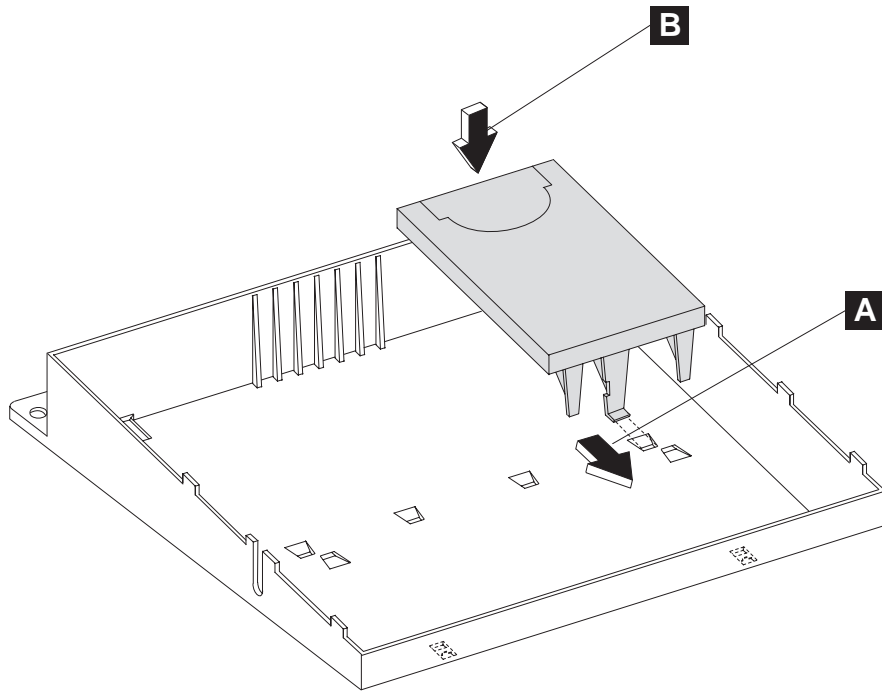

Figure 33. Installing the display filler

- A** Step 1
- B** Step 2

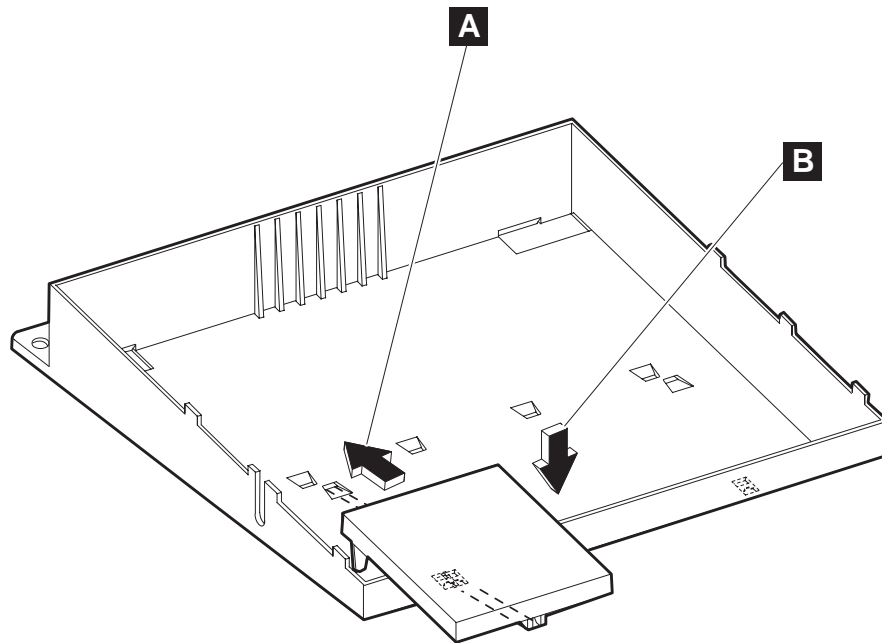

Figure 34. Installing the keyboard filler

- A** Step 1
- B** Step 2

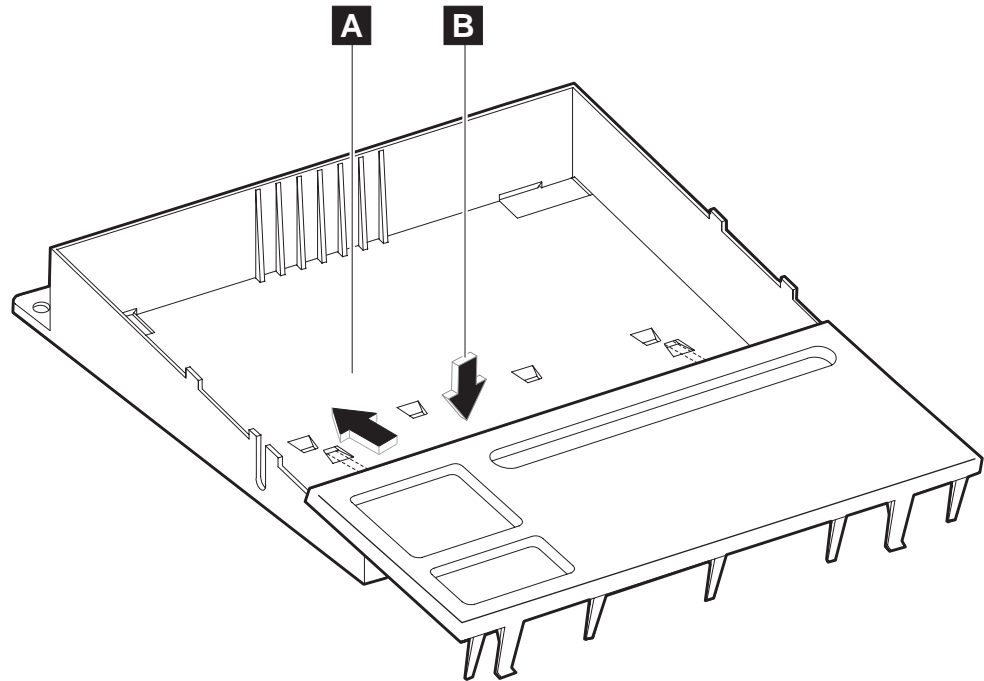

Figure 35. Installing the keyboard-replacement filler

**A** Step 1

**B** Step 2

To install the filler panels:

1. Place the display filler ( **A** in Figure 36) on the system unit. *Do not* remove the knockout section.

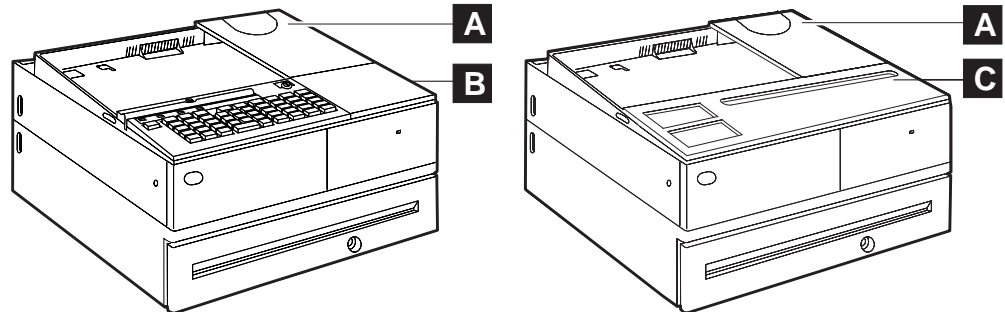

Figure 36. Location of installed fillers

2. If you have a 50-key keyboard or 50-key keyboard with MSR:
  - a. Place the keyboard filler panel ( **B** in Figure 36) beside the keyboard.
  - b. Hook the foot of the keyboard filler panel into the hole, and snap the front of the filler panel into place.
3. If you are using a touch screen and therefore are not using a keyboard, place the keyboard-replacement filler panel ( **C** in Figure 36) at the front of the unit. Hook the foot of the keyboard-replacement filler panel into the holes, and snap the front of the filler panel into place.

## Step 8. Connecting the power

To connect the power:

1. Connect the power cord to the rear of the SurePOS 700 and plug it into an electrical outlet.
2. If a UPS is attached, turn on the UPS (switch **H** in Figure 2 on page 6).
3. Verify that the UPS indicator light (LED) is on and operating correctly (**G** in Figure 2 on page 6).
4. Turn on the system unit (switch **F** in Figure 2 on page 6).
5. Verify that the SurePOS 700 is operating correctly by checking the LEDs on the front of the unit (see Table 8).

Table 8. Front panel LED status indicators

| Indicator                               | Status                  |  |
|---|-------------------------|--|
| Power ( <b>A</b> in Figure 2 on page 6) | <b>Steady</b>           | Power on   |
|   | <b>Blinking</b>         | Standby  |
|   | <b>No light</b>         | Power off  |
| HDD/Optical ( <b>B</b> )                | <b>Green</b>            | HDD or optical drive activity                    |
| INFO ( <b>C</b> )                       | <b>Amber</b>            | Hardware fault                                   |
| UPS ( <b>G</b> )                        | <b>Green</b>            | On AC power                                      |
|   | <b>Slowly blinking</b>  | On UPS internal battery power                    |
|   | <b>Blinking rapidly</b> | On UPS internal battery power and battery is low |

## Step 9. Running the BIOS configuration utility

Most users will not need to change the default BIOS configuration values, but you can change the system default settings if necessary. Chapter 5, "Diagnostics and configuration settings," on page 81 provides you with instructions on how to access and use the BIOS configuration utility.

---

## Chapter 3. Installing internal options

This section describes the installation procedures for the internal options for SurePOS 700 Models 723, E23, 743, C43, E43, 783, and E83.

**Attention:** When working inside the unit, be sure to observe the guidelines for personal grounding. For more information, see “Federal Communications Commission (FCC) statement” on page 109.

**Note:** UPS batteries have a three-year life expectancy. Make a note of the date that the battery is installed or replaced (see Figure 21 on page 28). A qualified<sup>2</sup> person can replace the battery. NVRAM batteries are typically good for the life of the product.

---

### Operating the front lock or lock plug

To operate the front lock or lock plug:

1. Open the front bezel door.
2. If a front lock insert is installed, insert the key.
3. To unlock, turn counterclockwise to the open position.  
To lock, turn clockwise to the closed position.

---

### Opening the drive bay door

To open the drive bay door:

1. Open the front bezel door.
2. Follow the steps in “Operating the front lock or lock plug” to unlock the front lock or lock plug.
3. Pull the drive bay door D-loop handle.

---

### Removing the covers

This section is provided for installation procedures that are not a part of an initial setup.

These steps apply to all models and to both the wide and narrow features. The covers consists of these parts:

- Front bezel
- Hinged rear door
- Top cover

---

2. Defined as a person with PC upgrade skills.

To remove the front bezel and top cover:

1. On the front bezel, press the left side tab ( **C** ) and depress the center tab ( **A** ) to loosen the bezel.

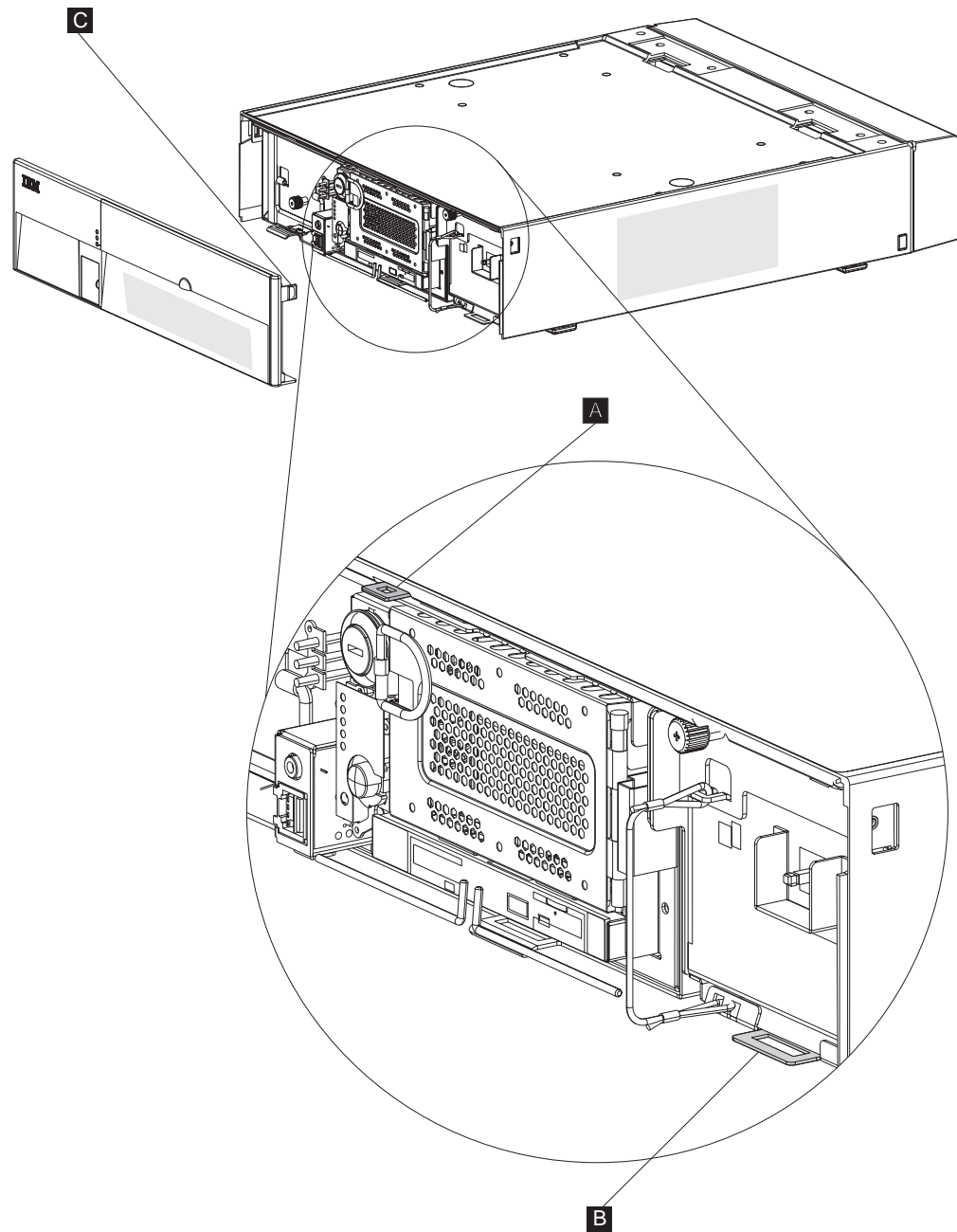

Figure 37. Removing the front bezel

2. Press the right side tab to release the bezel and pull it forward, lifting the bezel from the unit frame.

3. Open the hinged rear door by placing your hand firmly in the middle of the rear door and pulling. The lower tabs ( **A** in Figure 38) will release automatically (if not, press them in slightly, as shown by the arrow).

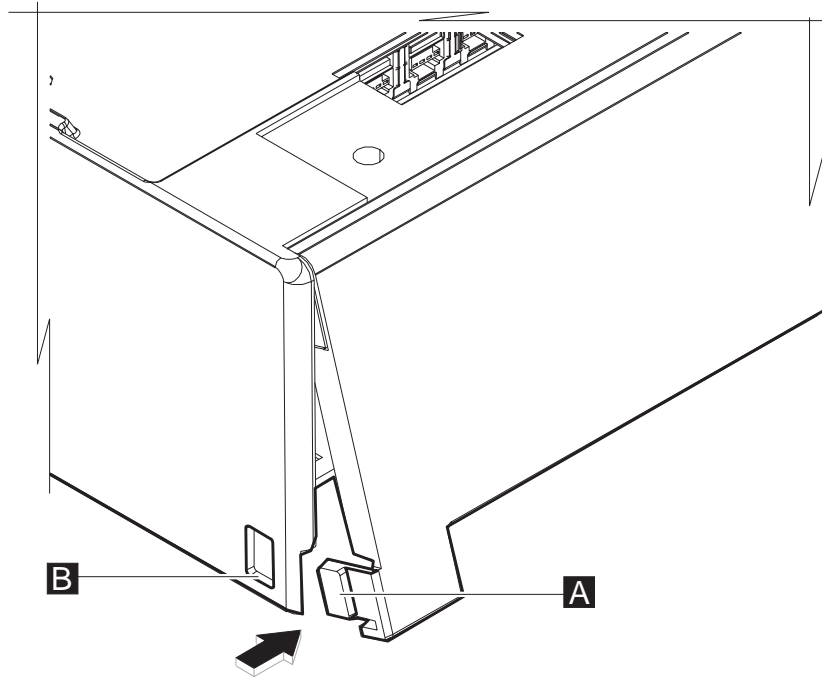

Figure 38. Opening the hinged rear door

4. Locate the metal holding clip located in the rear center of the top cover ( **A** in Figure 39). Push this clip downward and push the cover backward a few inches, then lift upward to remove.

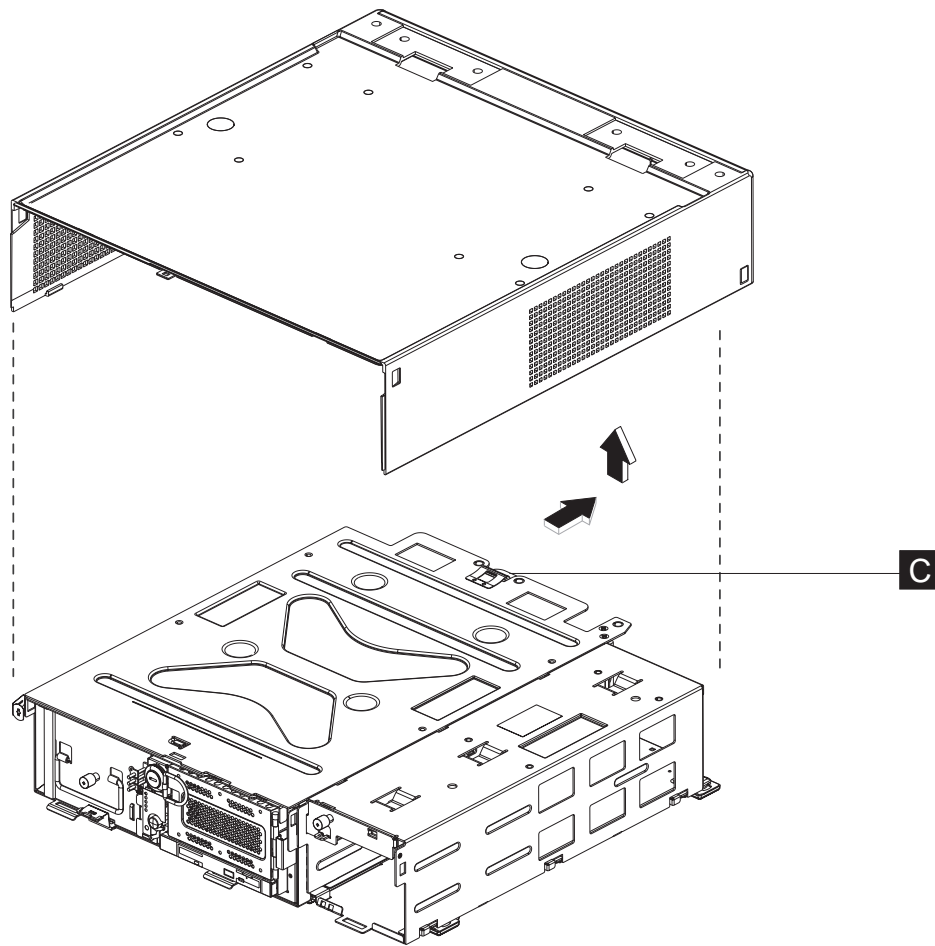

Figure 39. Removing the top cover

To replace the front bezel and top cover, see “Step 3. Installing the covers” on page 31.

## Removing the pullout tray

To remove the pullout tray from the unit frame:

1. Remove the front bezel by following the steps in “Removing the covers” on page 43.
2. If necessary, unlock the front lock.
3. Remove all cable attachments which will restrict removal of the pullout tray.
4. While holding the unit frame in place, grab the pullout tray handle ( **A** in Figure 40), use your thumb to lift the pullout tray lock tab ( **B** ), and pull firmly. The pullout tray will slide out of the unit frame completely.

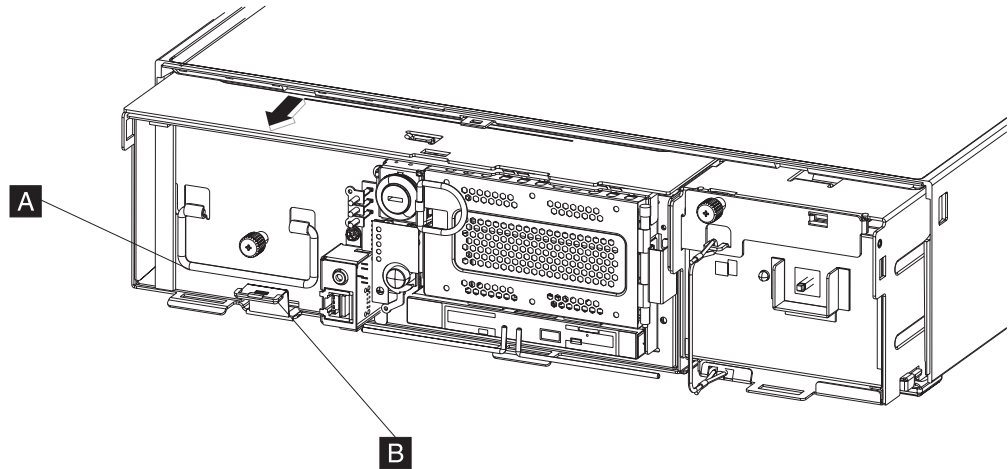

Figure 40. Removing the pullout tray from the unit frame

**Note:** Be sure to support the pullout tray, if you remove it completely.

To replace the pullout tray, insert the rear of the pullout tray into the front of the unit frame and gently slide back until the pullout tray lock tab ( **B** ) locks into place.

## Installing a feature card

This section is provided for installation procedures that are not a part of an initial setup.

**Attention:** Establish personal grounding before working inside the unit. For more information, see “Federal Communications Commission (FCC) statement” on page 109.

To install a feature card:

1. Follow the instructions in “Removing the pullout tray” on page 47.
2. See Figure 41 to locate the feature card slots. Remove the slot covers on each slot that is going to receive a feature card.
3. Align the feature card connectors with the slots. Insert the card firmly into the slots.

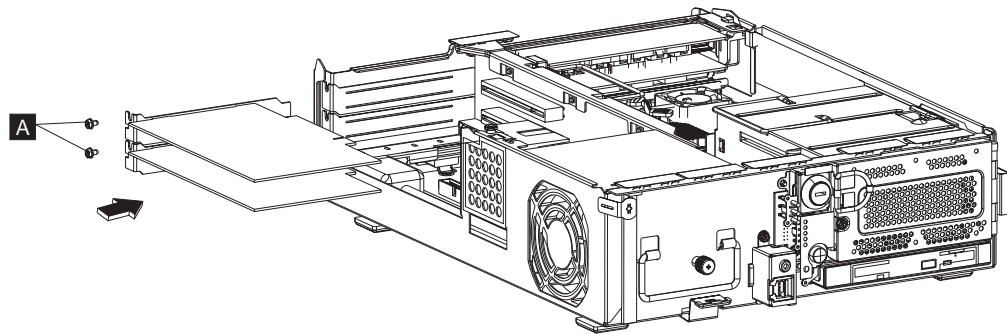

Figure 41. Installing feature cards

4. Insert the retaining screw ( **A** in Figure 41).

## Installing memory modules

This section is provided for installation procedures that are not a part of an initial setup.

**Attention:** Establish personal grounding before working inside the unit. For more information, see “Federal Communications Commission (FCC) statement” on page 109.

**Note:** It is not necessary to completely remove the pullout tray to install memory modules; you can install them by just pulling the tray out half way.

1. Note the off-center alignment notch along the bottom of the module where it plugs into the connector. This notch aligns with a key in the memory slot.

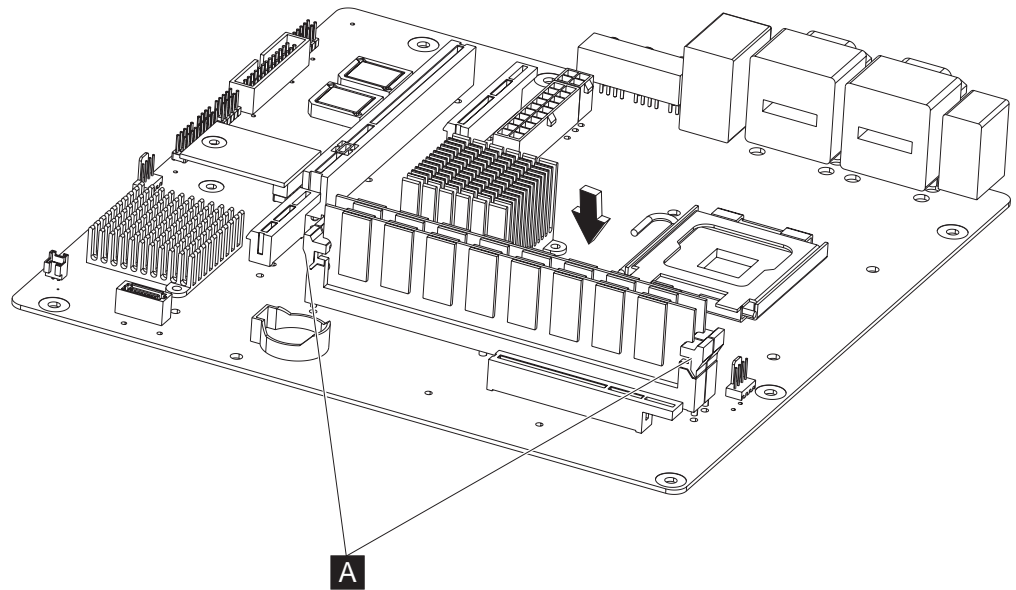

Figure 42. Replacing the memory modules

2. Touching only the top corners of the memory module, align the connector tabs and press down firmly. The white tabs ( **A** in Figure 42) on the connector on the planar board close as the module is inserted.
3. Ensure that the white tabs are pressed in towards the center as far as they can pivot. When inserted correctly, the white tabs are completely closed.



---

## Chapter 4. Installing external options

This section describes the installation procedures for the external options for SurePOS 700 Models 723, E23, 743, C43, E43, 783, and E83.

---

### Before you begin

These instructions describe how to install devices and connect cables on the SurePOS 700.

**Note:** Not all device options can be integrated on narrow-footprint system units.

Your store planner should provide instructions that show all of your system devices and where you should connect them. If that arrangement is different from that which is explained in this chapter, follow the planner's instructions.

You can place the printer, short keyboard, displays, and fillers on the left or right side of the unit.

After you complete the installation of I/O devices, save any publications or diskettes that came in the OPEN FIRST box and configure the system unit.

---

### Attaching the cables to the system unit

The POS I/O cables developed by IBM all have latches or screws to secure them to the system unit and, thus, prevent accidental disconnection. Cables are sometimes used that do not provide latches or screws, such as standard PC USB cables. The SurePOS 700 provides several methods to secure such cables.

## Securing IBM USB POS keyboard cables

If you ordered a USB POS keyboard from IBM with a standard PC USB connection, the cable ships with a locking clip. Figure 43 shows the steps to secure the cable using the clips and brackets:

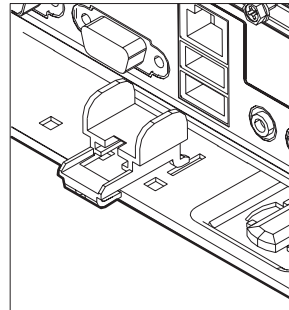

1

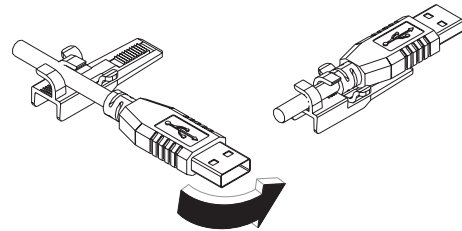

2

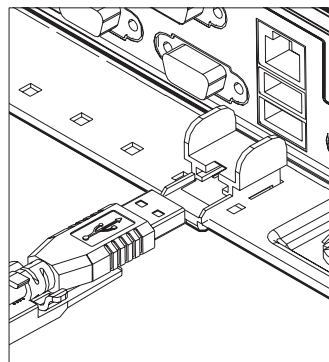

3

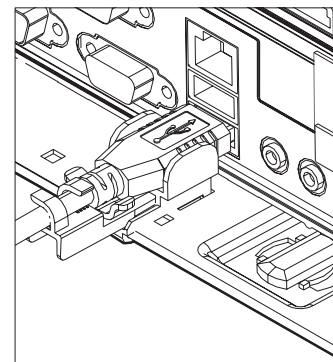

4

Figure 43. Pictorial steps to attach the cable with clips and brackets

1. Align the clip bracket with the holes provided on the rear base of the system unit. Press down and push forward on the bracket to lock it into place.
2. Align the USB cable with the cable clip. Holding the clip and the cable together, rotate the clip clockwise around the cable to connect the clip to the cable.
3. Slide the USB cable and clip assembly into the bracket.
4. Connect the cable to the system unit. Be sure to push the cable and clip assembly firmly against the edge of the system unit to secure the connection.

## Securing the cable using cable ties

Without a provision to latch or screw a cable in position, you can secure the cable using cable ties:

1. Plug the cable into the system unit. Loosely place the cable cord to either the left or right side of the connector.
2. Wrap the cable tie around the cable cord and through the hole located in the base of the system unit.

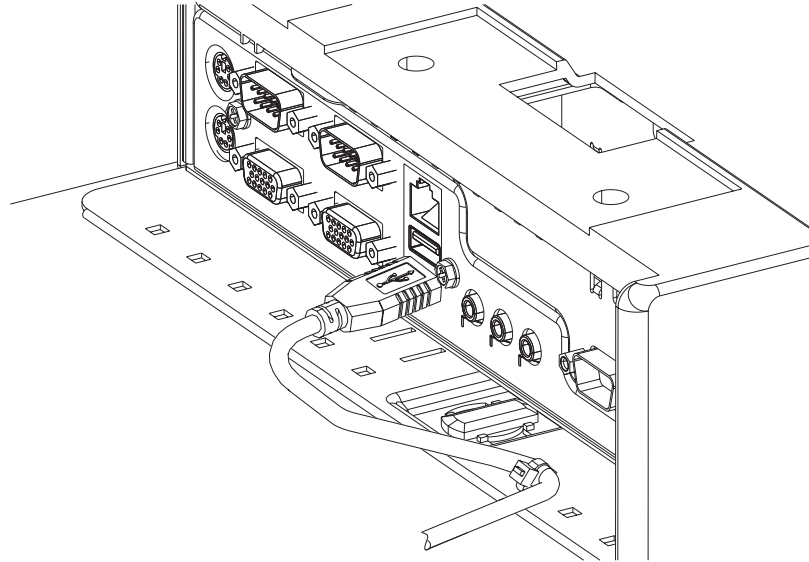

*Figure 44. Securing the cable with cable ties*

3. Tighten the cable tie to secure the cable. Your connection should place no pressure on the cable connector, but instead secure the cable cord to the system unit.

---

## Installing the system unit on a cash drawer

**Notes:**

1. These instructions apply to both the compact cash drawer and full-size cash drawer.
2. You can secure the cash drawer to the top of a counter with the M6 threaded inserts in the bottom of the cash drawer. Be sure the screws do not extend past the inserts and contact the drawer.

## Setting the jumper for the correct voltage for non-IBM cash drawers

The SurePOS 700 Models 723, E23, 743, C43, E43, 783, and E83 are preconfigured from the factory to work correctly with all IBM cash drawers. Connecting your IBM cash drawer to port 3A on the system unit activates the autosensing circuitry. The system unit can then detect the difference between IBM 24 V and IBM 38 V cash drawers.

**CAUTION:**

**If you are using a non-IBM cash drawer then the automatic mode does not work and damage to either the cash drawer, system unit, or both is possible. See “Cash drawers” on page 17 for complete information on manually setting the voltage.**

## Installing the cash drawer

To install the cash drawer and the system unit:

1. Place the cash drawer in the preferred location. You can use the optional mounting brackets to bolt the cash drawer under the counter.
2. If the unit is integrated, place the system unit on top of the cash drawer.

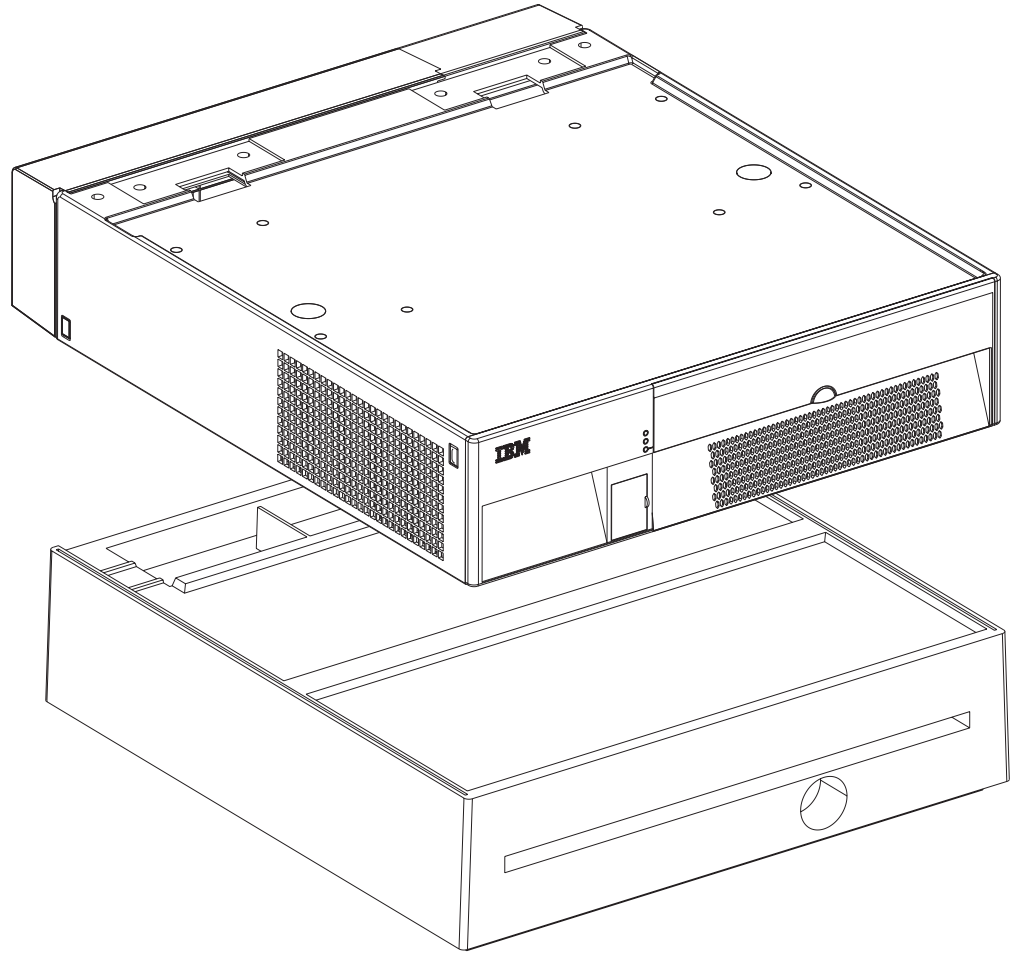

*Figure 45. Place the system unit on the cash drawer*

3. Push in the side buttons ( **A** in Figure 46) on the rear cover of the cash drawer to open it, and then remove the rear cover **D**.

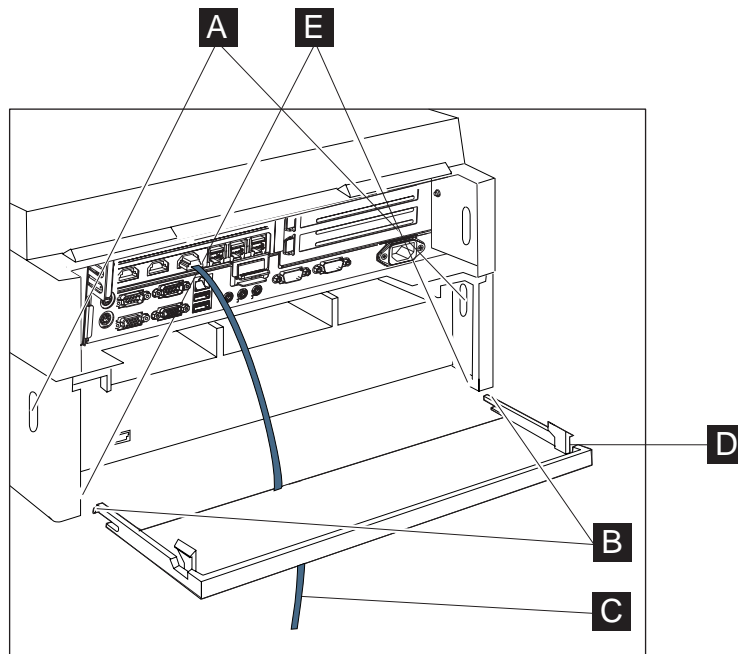

Figure 46. Installing cash drawer cables

4. Connect the cash drawer cable **C** to port 3A or port 3B on the rear panel of the system unit.
5. Connect the other end of the cable to the rear of the cash drawer (port 3).
6. Connect the AC power cord to the system unit.

**CAUTION:**

**Do not plug the other end of the power cord to an outlet yet.**

7. Route the power cord down toward the bottom of the cash drawer.
8. Replace the rear cover by aligning the cover tabs **B** with the pins **E**, and then press inward to install it.
9. Close the cash drawer's rear cover, which will hide the power cord.

## Installing the cash drawer coin roll cutter (compact cash drawer only)

To install a compact cash drawer coin roll cutter:

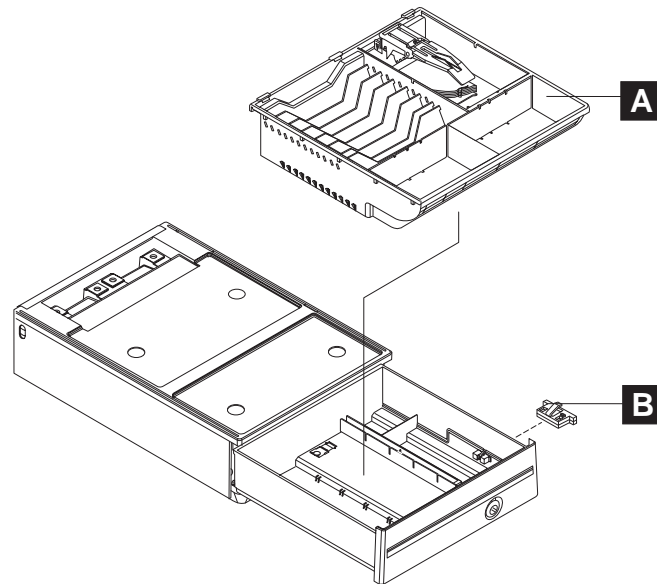

Figure 47. Install coin roll cutter

1. Open the cash drawer and pull it completely out.
2. Remove the till (see **A** in Figure 47).
3. From inside the drawer, squeeze the cutter latches together with your fingers and push the coin roll cutter (**B**) outward until you can remove it from the outside.
4. To exchange the coin roll cutter, snap the new one into position from the outside.
5. Reassemble.

## Installing I/O trays

This section describes how to install an I/O tray on the system unit and on the full-size cash drawer.

### Installing an I/O tray on the system unit

To install an I/O tray on the system unit:

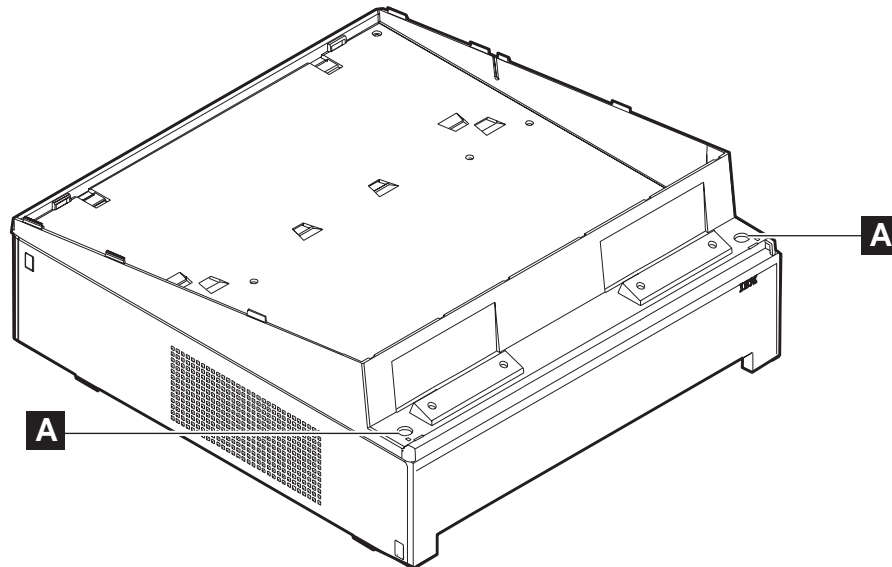

Figure 48. Installing the slanted I/O tray

1. Install the two mounting tabs into the slanted I/O tray. From the inside of the I/O tray, insert the back of the mounting tab first and then push the front part into the opening.
2. See Figure 48. Turn the I/O tray over. Push on the front of the tab until it locks into place.
3. Position the I/O tray on top of the system unit and insert the tabs into the slots on the system top cover or on the cash drawer.
4. Attach the I/O tray to the system unit by inserting and tightening the two plastic thumbscrews ( **A** in Figure 48) into the holes at the back corners of the I/O tray.

## Installing a slanted I/O tray on the full-size cash drawer

To install a slanted I/O tray on the full-size cash drawer:

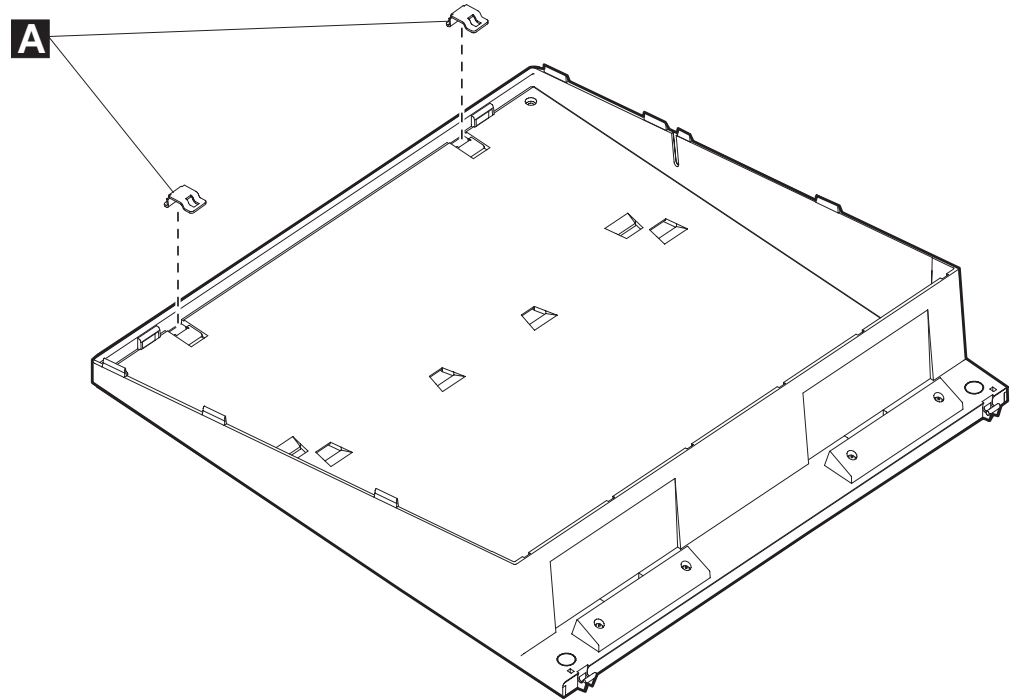

Figure 49. Installing two mounting tabs into the slanted I/O tray

1. If an IBM 4820 SurePoint Solution display is to be installed on the cash drawer, install one of the steel insert features (P/N 99P9871) before mounting the slanted I/O tray.
2. Install the two mounting tabs ( **A** ) into the slanted I/O tray.
  - a. From the inside of the I/O tray, insert the back of a tab first and then push the front part into the opening.
  - b. Turn the I/O tray over.
  - c. Push on the front of the tabs until they click into place.
3. Set the I/O tray on top of the full-size cash drawer.
4. Connect the tabs in front of the cash drawer.
5. Attach the I/O tray to the cash drawer by inserting and tightening the two plastic thumbscrews into the holes at the back corners of the I/O tray.

---

## Installing the fillers

To install the fillers, see “Step 7. Installing the fillers on a slanted I/O tray” on page 38.

---

## Installing the tape-holder kit

To install the tape-holder kit:

1. Using a screw driver or a coin, remove the tape-holder latch.

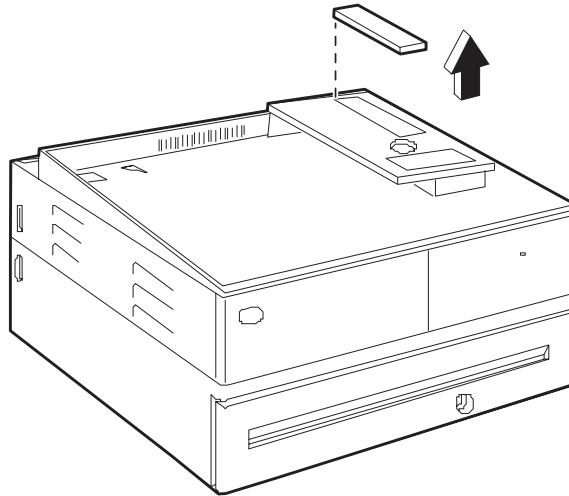

*Figure 50. Removing the tape-holder latch*

2. Install the tape holder in the slot by pulling the tape holder forward until it snaps into place.

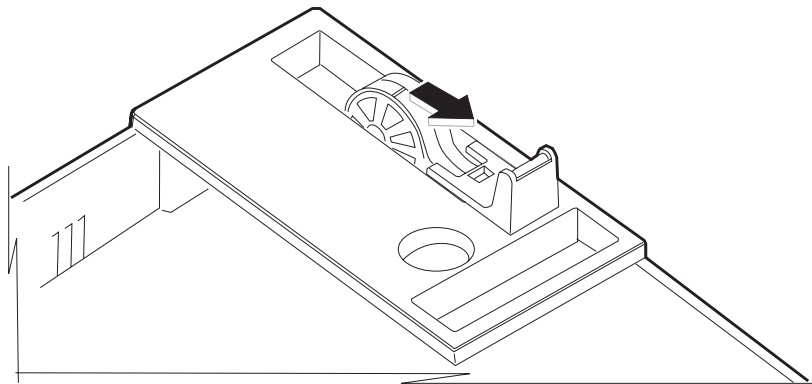

*Figure 51. Snapping the tape-holder into place*

## Installing the printer

The SurePOS 700 can support several models of the IBM SureMark printer. The removal procedures and the installation are the same for all models of the printer.

**Attention:** If you are installing a non-USB printer, turn the system unit power OFF.

**Note:** The 4689 DBCS SurePOS Receipt Journal (RS-485) printer requires the voltage to be set at 24 V. All other RS-485 printers will work correctly at 38 V. See “Voltage setting for the 4689 DBCS SurePOS Receipt Journal printer” on page 18 for additional information.

To install the printer:

1. Remove any packing material from inside or under the printer.
2. Connect the printer cable to the bottom of the printer.
3. If an I/O tray is installed, route the cable through the nearest opening at the rear of the I/O tray. Place the printer on the system unit.
4. If your model has a slanted I/O tray, be sure the side of the printer overlaps the tab ( **A** in Figure 52) on the side of the slanted I/O tray.

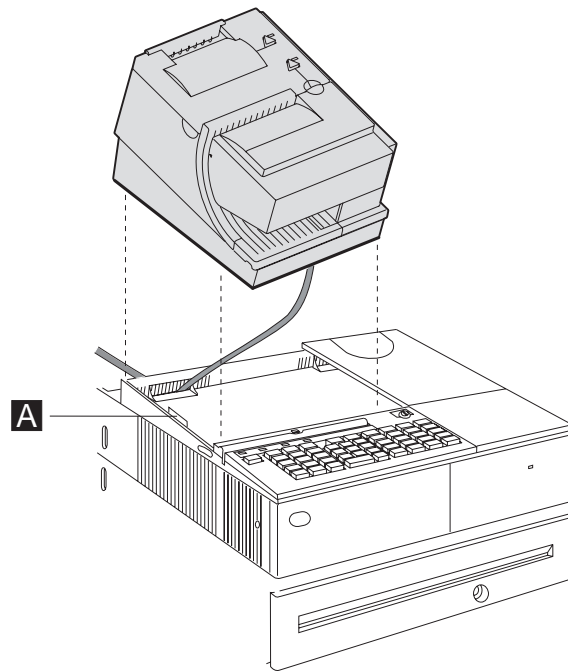

Figure 52. Install the printer

5. If you are installing a printer on an integrated wide-footprint model and are not using a wedge-mounted CRT as the display, you must also install a credit-card-holder filler panel.
6. For a non-USB printer, connect the printer cable to the RS-232 port or to the RS-485 port number 7.
7. For a non-USB printer, perform an initial program load (IPL) on the application so that the application recognizes the attachment of the printer.
8. Install any other external options as required.

For any other questions regarding the printer, refer to the *IBM SureMark 4610 Printers User's Guide*.

## Installing the 40-character LCD

1. Route the display cable up through the head assembly ( **B** in Figure 53) and out the opening on the side. Then route the cable down through the post ( **D** ) and optional extension ( **C** ).

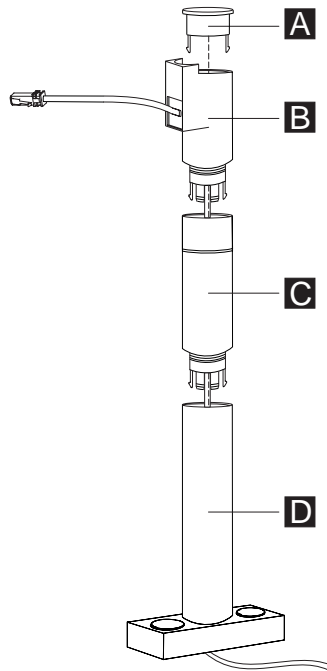

Figure 53. Assemble the post

2. Snap the head assembly onto the post.
3. Slide the display up into its holder until it latches securely in place.

**Note:** Depending on the direction you want the display to face, the holder can be attached two different ways.

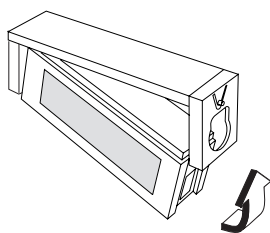

Figure 54. Slide display into holder

4. Plug the cable into the display unit.

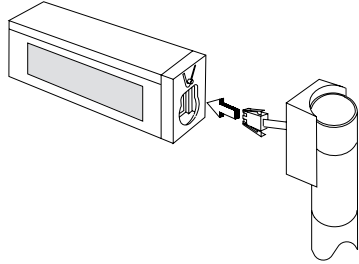

Figure 55. Plug cable into display unit

5. Hold the display holder against the post as shown in Figure 56 so the interlocking surfaces touch each other.

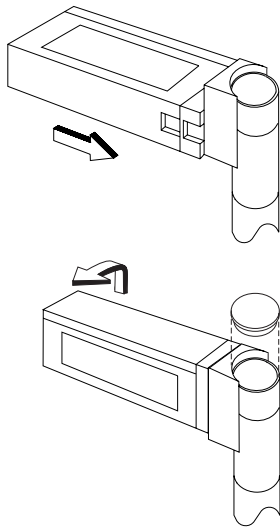

Figure 56. Assembling the display

6. Rotate the display holder to its final position. Ensure the display is securely attached to the post.
7. Snap the round top cover ( **A** in Figure 53 on page 62) onto the post.
8. Route the cable through the opening in the system unit or cash drawer at the base of display.
9. Attach the display post to the system unit or cash drawer at **A** or **B** in Figure 57 on page 64, using two plastic thumbscrews. The base is not symmetrical and will fit only one way.

**Note:** Use long thumbscrews when installing the display without a slanted I/O tray.

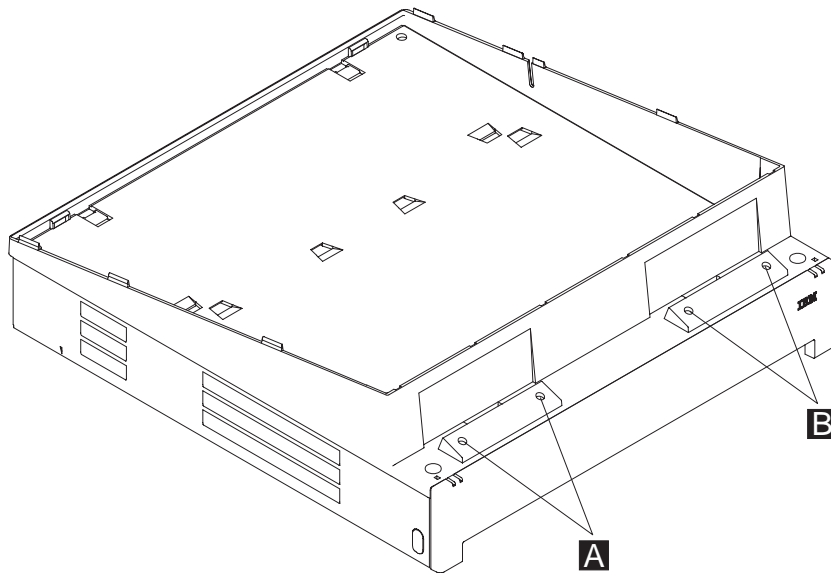

Figure 57. Attachment points for the display post

10. Attach the display cable to a 12 V (green) powered USB port at the rear of the system unit, or attach the display cable to the RS-485 port number 4 at the rear of the system unit.
11. Install any other external options as required.

**Notes:**

- a. Two displays can be stacked on a single post by inserting another head assembly instead of the round top cover. Either display can face toward the front or the rear.
- b. For a second display, plug a second powered USB cable into a 12 V (green) powered USB port on the rear of the system unit. You can attach two RS-485 displays to a system unit with a Y-cable.

---

## Installing the 40-character VFD

To install the 40-character vacuum fluorescent display (VFD):

**Note:** The yoke for a two-sided display is taller than the yoke for a single-sided display. The installation procedure is the same for both.

1. Connect the yoke ( **A** in Figure 58 on page 65) to post ( **B** ). If required, add the extension post ( **C** ) between **A** and **B** .

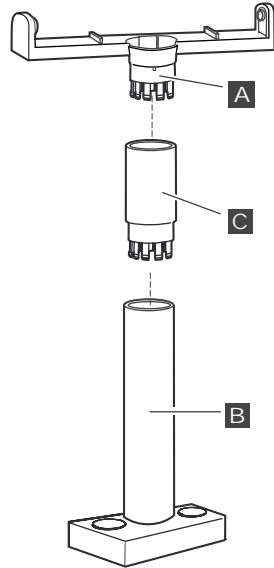

Figure 58. Assemble the post

2. Route the display cable through the post.

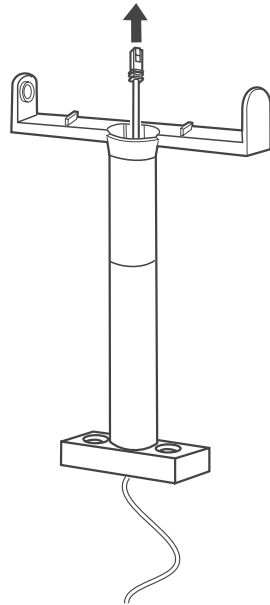

Figure 59. Routing the cable

3. Connect the display cable ( **A** in Figure 60 on page 66) to the display unit. Spread the arms on the display ( **B** ) slightly, and install the display unit ( **C** ).

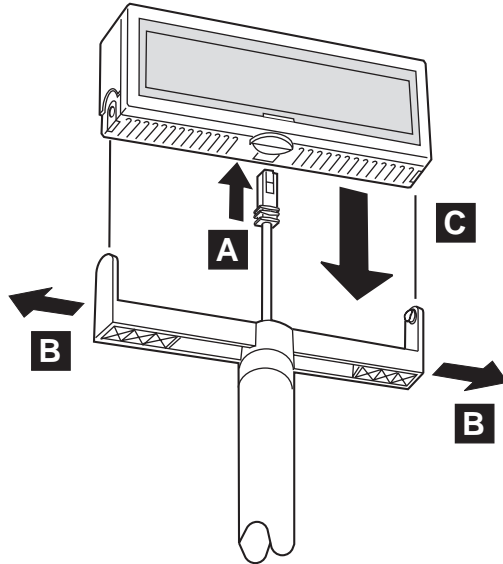

Figure 60. Placement of the display on the arm

4. Route the display cable through the rear of the POS terminal ( **A** in Figure 61) and screw the post to the POS terminal ( **B** ).

**Note:** Use long thumbscrews when installing the display without a slanted I/O tray.

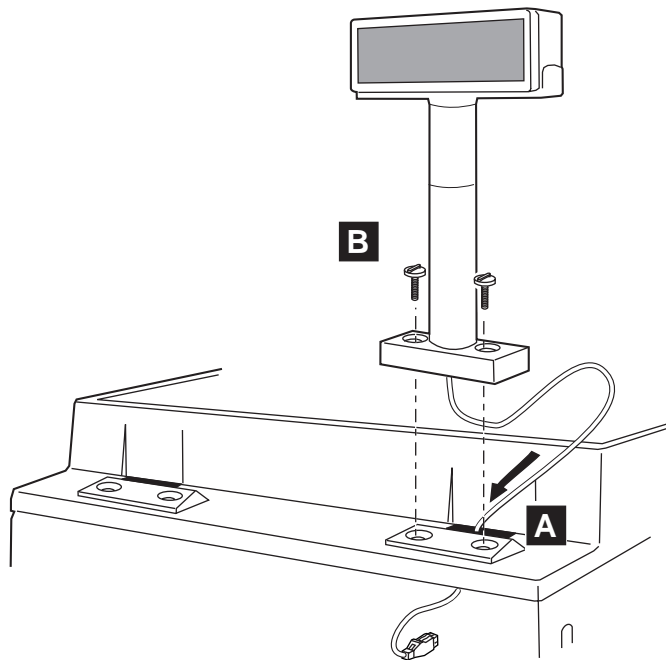

Figure 61. Routing the cable

5. Connect the other end of the display cable to any 12 V (green) powered USB port on the rear of the system unit. You can also connect the end of the display cable to the RS-485 number 4 port on the rear of the system unit.

## Installing the character/graphics display

This section describes how to install a character/graphics display. You install the display post with either a snap or a base.

### Installing the display post with a snap

To install the character/graphics display post with a snap to the POS terminal:

1. Confirm that the character/graphics display filler is installed.
2. Connect the character/graphics display ( **A** ) to the post ( **B** ).

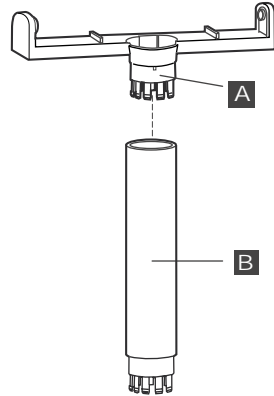

Figure 62. Connecting the character/graphics display post

3. Route the character/graphics display cable from the rear of the POS terminal ( **A** in Figure 63), through the hole on the filler ( **B** ), and through the post ( **C** ).

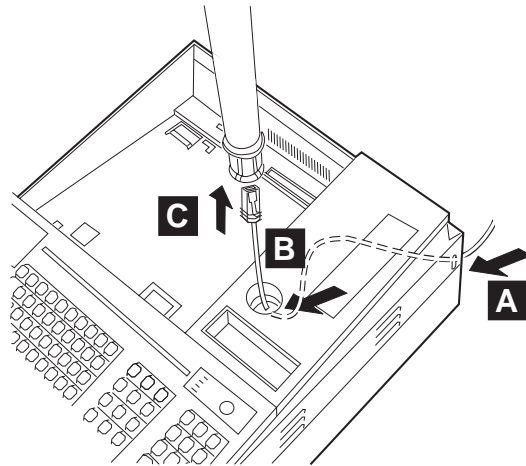

Figure 63. Routing the character/graphics display cable

4. Connect the display cable **A** to the display unit.
5. Spread the arms on the character/graphics display ( **B** ) slightly, and install the display unit ( **C** ).

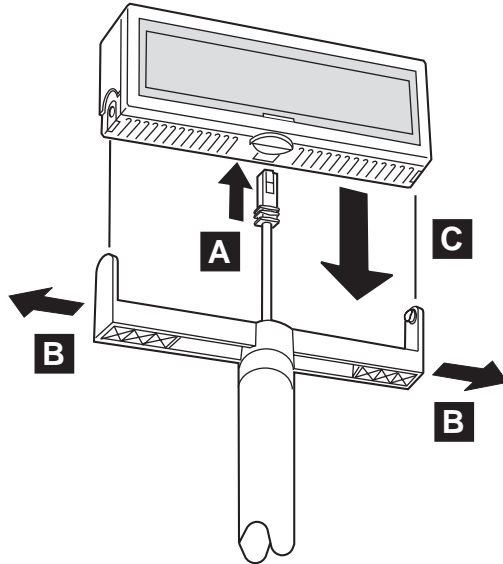

Figure 64. Installing the character/graphics display

6. Fit the post into the hole on the filler.

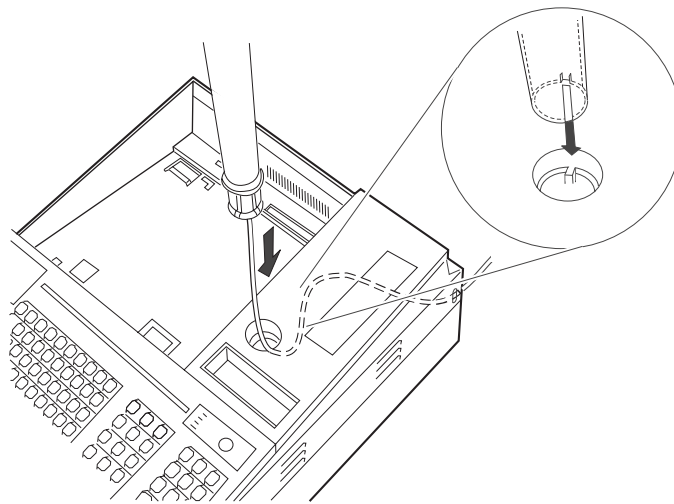

Figure 65. Placing the post into the filler hole

7. Connect the other end of the character/graphics display cable to any 12 V (green) powered USB port on the rear of the system unit. Or, connect the other end of the character/graphics display cable to the RS-485 number 4 port on the rear of the system unit.

## Installing the display post with a base

To install the display post with base to the POS terminal:

1. Connect the display ( **A** in Figure 66) to the post ( **B** ). If required, add the extension post ( **C** ) between **A** and **B** .

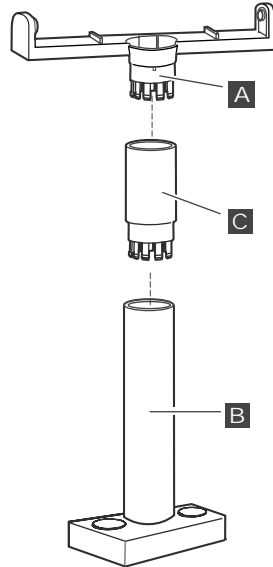

Figure 66. Connecting the character/graphics display post

2. Route the character/graphics display cable through the post.

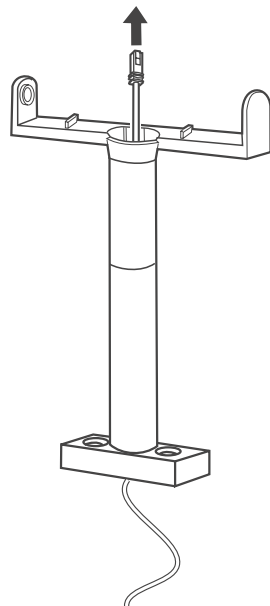

Figure 67. Routing the cable

3. Connect the display cable ( **A** in Figure 68 on page 70) to the display unit. Spread the arms on the character/graphics display ( **B** ) slightly, and install the display unit ( **C** ).

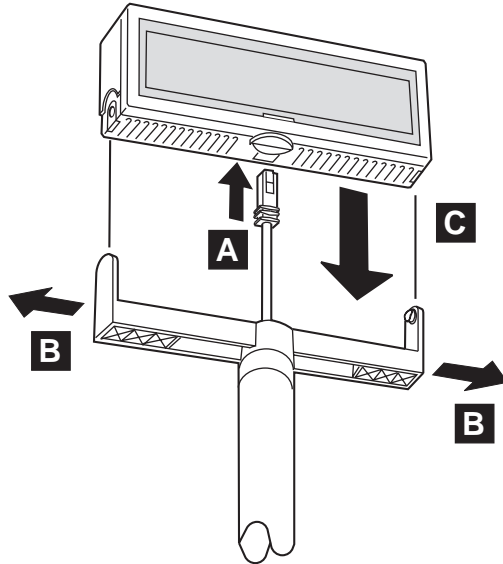

Figure 68. Placement of the character/graphics display on the arm

4. Route the display cable through the rear of the POS terminal ( **A** in Figure 69), and screw the post to the POS terminal ( **B** ).

**Note:** Use long thumbscrews when installing the display without a slanted I/O tray.

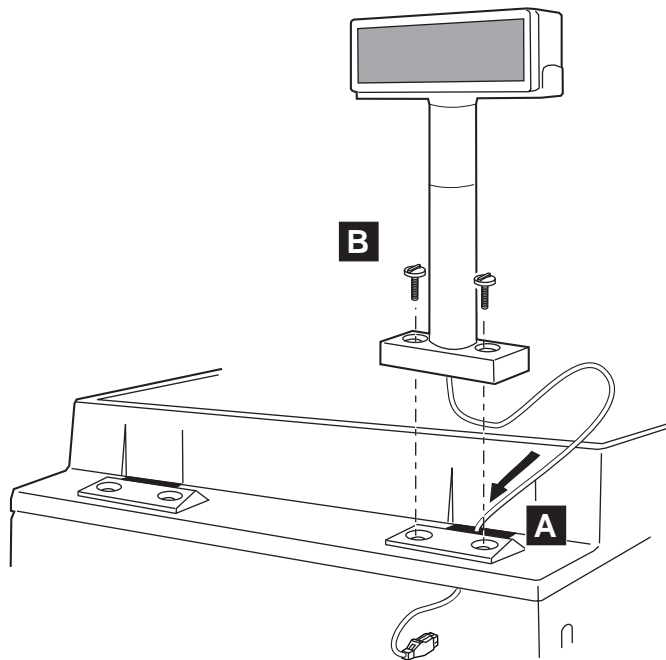

Figure 69. Routing the cable

5. Connect the other end of the character/graphics display cable to any 12 V (green) powered USB port on the rear of the system unit. Or, connect the other end of the character/graphics display cable to the RS-485 number 4 port on the rear of the system unit.

## Installing the guidance label

To install the guidance label on the display unit:

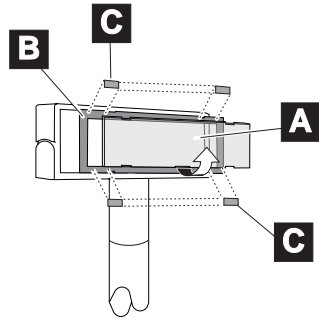

Figure 70. Installing the guidance label

1. Insert your finger into the slit on the filter and lift up the filter ( **A** ).
2. Remove the character sheet ( **B** ).
3. Stick the guidance labels ( **C** ) on the upper and lower portions of the character sheet. Ensure that the right edge of the label aligns with the right edge of the sheet.
4. Reinstall the character sheet.
5. Reinstall the filter.

---

## Attaching an IBM SurePoint Solution

For information about attaching an IBM SurePoint Solution display, refer to the *IBM 4820 SurePoint Solution Planning, Installation and Service Guide, GA27-4231*.

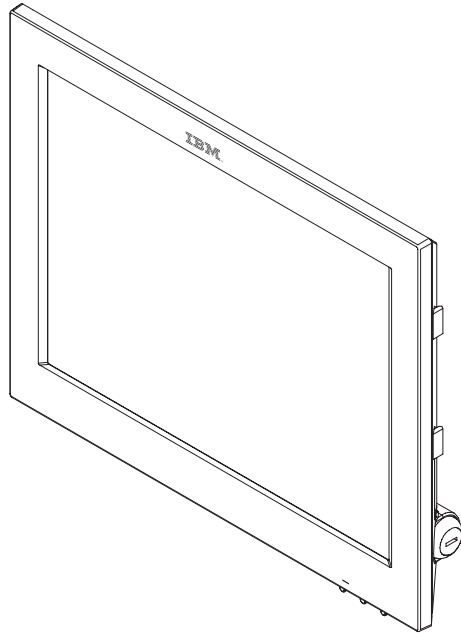

Figure 71. IBM SurePoint Solution display

## Installing and removing lock inserts

The cash drawer, keyboard, and Model 4 printer can have optional locks that prevent unauthorized persons from using the terminal. If no lock is installed, a blank lock insert can be used to cover the opening.

### Preparing to install a lock or a blank lock insert

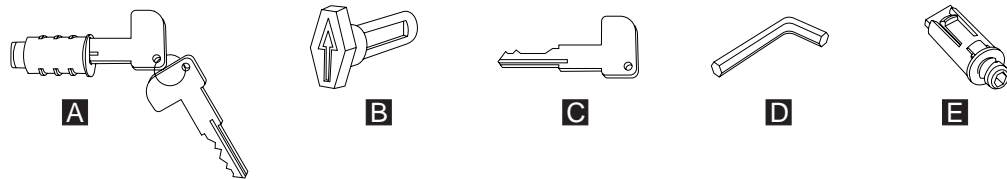

Figure 72. Lock inserts and accessories

To install a lock insert, you need the following items:

- A** Lock insert and keys
- B** Aligner
- C** Brass installation and removal key

To install a blank lock insert, you need the following items:

- D** Blank lock installation handle
- E** Blank lock insert

The aligner is a tool used to ensure that the slot at the bottom of the lock cylinder aligns with the lock insert that is being installed.

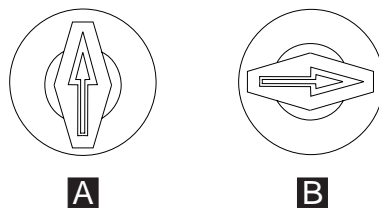

Figure 73. Aligner positions

Figure 73 shows the aligner in place in the lock cylinder of the cash drawer or keyboard (**A**) or Model 4 printer (**B**). The arrow will point in different directions, depending on the kind of device. Refer to this figure when you install a lock in the different devices.

### Installing a lock insert

The procedure is the same for installing a lock insert in any device. Only the aligner position changes from device to device (see Figure 73 and the related text). To ensure that the slot at the bottom of the lock cylinder is in alignment with the end of the lock insert:

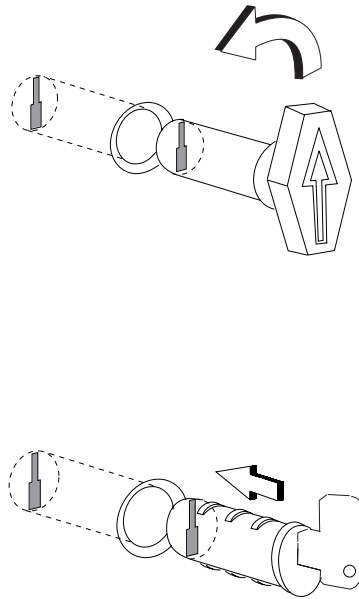

Figure 74. Install a lock insert

1. Put the aligner into the empty lock cylinder.
2. Gently turn the aligner until you feel it insert into the slot at the bottom of the lock cylinder.
3. Turn the aligner so that the arrow points in the correct direction for this device.
4. Remove the aligner.

**Note:** Some cash drawers might have a different style lock. If the lock for your cash drawer is different than the one described here, refer to the instructions that came with the lock.

Be sure that each lock insert and its keys have matching numbers. To install the lock insert:

1. Remove the keys from the lock insert.
2. Push the brass installation and removal key *completely* into the lock insert.
3. Hold the lock and brass key so that the key points in the same direction as did the aligner.
4. Push the brass key and lock insert *completely* into the empty lock cylinder.
5. Hold the lock insert in place with your finger and remove the brass key. The lock insert is now installed.
6. Test the lock to be sure it operates correctly with the keys.
7. Return the brass installation and removal key, the aligner, and the blank lock installation handle to your supervisor for safekeeping.

## Installing a blank lock insert

Blank lock inserts are used to cover the opening at the lock cylinder if no lock has been installed.

1. Hold the blank lock insert so that the lug is aligned with the slot in the lock cylinder.

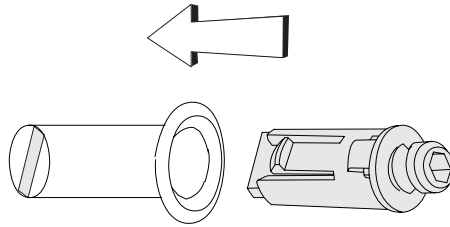

Figure 75. Align the lug with the slot in the lock cylinder

2. Push the blank lock insert into the empty lock cylinder until it is flush with the top of the lock cylinder.
3. Use the blank lock installation handle to turn the locking screw clockwise until it reaches the bottom of the hole. Do not overtighten. The blank lock insert is now installed.

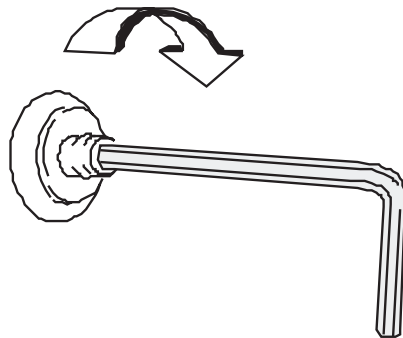

Figure 76. Turn the locking screw

4. Return the brass installation and removal key, the aligner, and the blank lock installation handle to your supervisor for safekeeping.

## Removing a lock insert

To remove a lock insert:

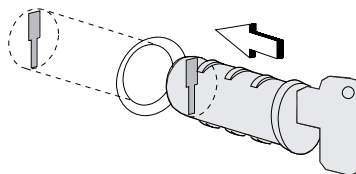

Figure 77. Remove a lock insert

1. Insert the brass installation/removal key into the lock until you hear it click into place.
2. Gently pull the brass key.  
The brass key and the lock insert should come out of the lock cylinder together. Pressing down on the brass key as you pull makes it easier for the lock insert to come out along with the brass key.

**Note:** See “Installing and removing lock inserts” on page 72 to reinstall a lock insert or a blank lock insert.

## Removing a blank lock insert

To remove a blank lock insert, use the blank lock installation handle to turn the locking screw counterclockwise until you can lift the blank lock insert out of the lock cylinder.

**Note:** See “Installing and removing lock inserts” on page 72 to reinstall a lock insert or a blank lock insert.

---

## Installing the keyboard-V and the PLU keyboard

When you install a keyboard-V or the PLU keyboard, you can perform any of these tasks:

- Change the keytop label
- Change the keyboard layout
- Change the keytops

## Changing the keytop labels

To change the keytop labels:

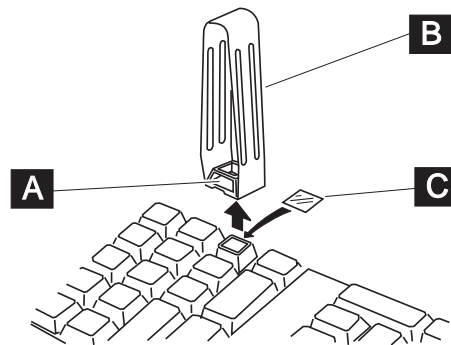

Figure 78. Installing the keytop labels

1. Insert the keytop remover ( **A** ) into a key ( **B** ) and remove the keycap.
2. Place the label ( **C** ) on the keytop.
3. Install the transparent keycap on the keytop.

**Note:** The USB keyboard-V and the PLU keyboard are not shipped with transparent keycaps; they are shipped with solid keycaps.

---

## Installing a vertical stand

To install your system onto a vertical stand:

1. Place the vertical stand in the location where the system unit will operate.
2. Position the system unit on the vertical stand as shown in Figure 79 on page 76. The front bezel door should be located closer to the stand with the air vents on top and unobstructed.

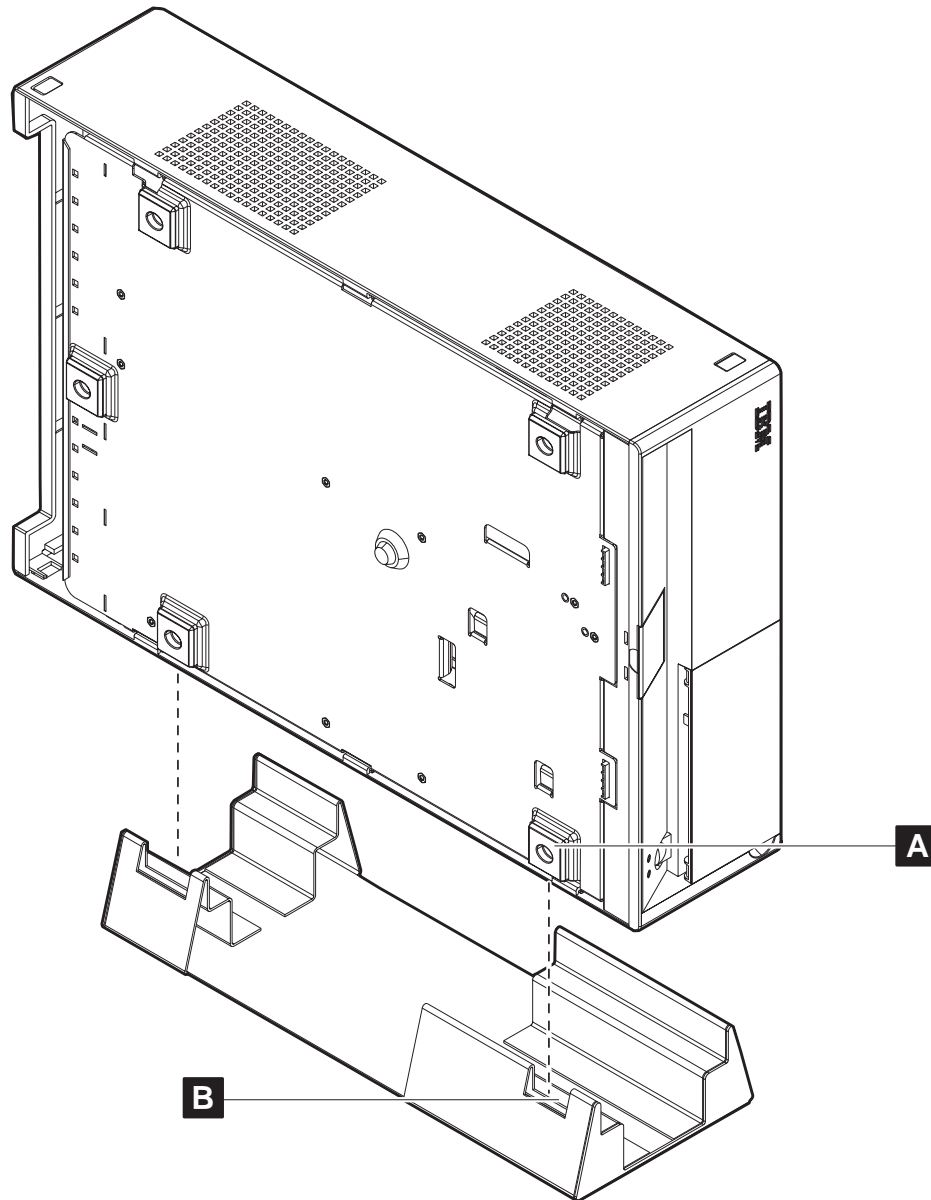

Figure 79. Placing the system unit on the vertical stand

3. Insert the front foot ( **A** ) of the system unit into the notch ( **B** ) in the stand.

---

## Installing cables

This section details how to install the cable guide and cable guide arm assembly, and it offers advice on how to route the cables.

## Installing the cable guide and the cable guide arm assembly

**Note:** Install the optional cable guide and cable guide arm assembly before inserting the system unit into the housing.

To install the cable and cable guide arm assembly:

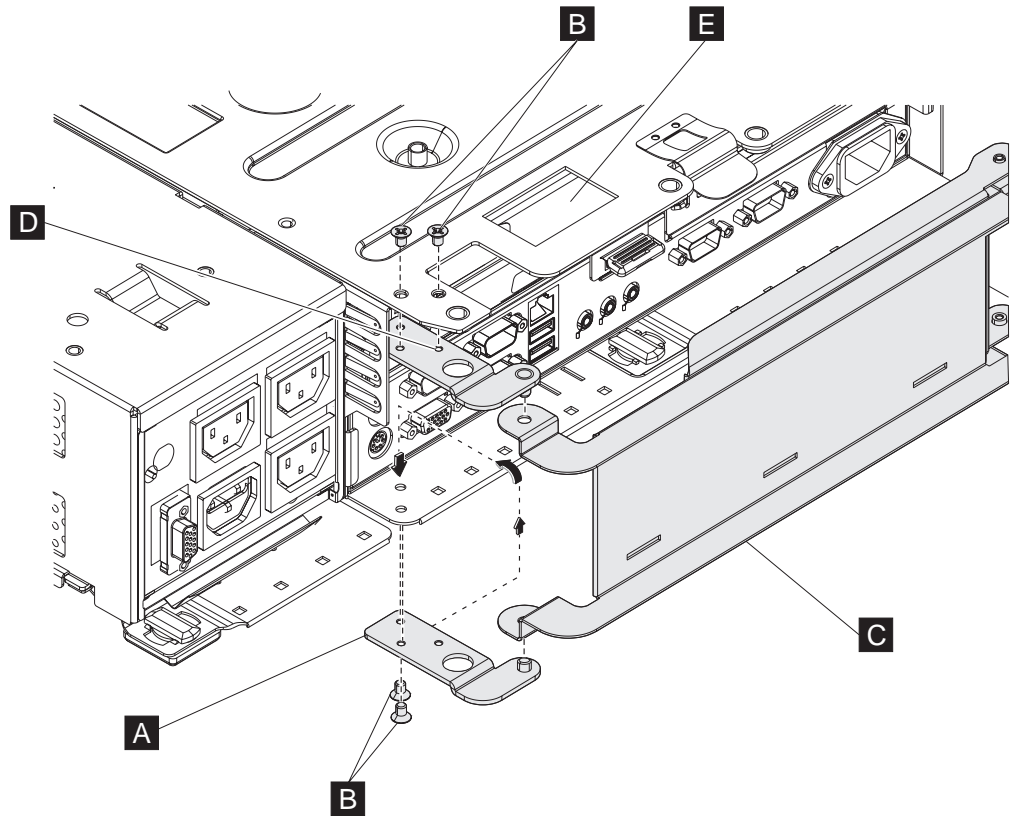

Figure 80. Installing the cable guide arm assembly

1. Attach the bottom bracket ( **A** in Figure 80) to the bottom of the system tray using the two screws ( **B** ).
2. Position the cable guide arm assembly ( **C** ) on the post on the bottom bracket.
3. Insert the top bracket ( **D** ) post into the hole on top of the cable guide arm assembly, and use the two screws ( **B** ) to install the top bracket.
4. Proceed with "Routing the cables."

## Routing the cables

For ease of installation, IBM recommends that you route the cables in this order:

1. Power cord
2. Ethernet
3. Cash drawer and other peripheral devices (mouse, keyboard, printer)

To route the cables:

1. Remove the rear door from the top cover.
2. Complete the instructions described in "Installing the cable guide and the cable guide arm assembly" on page 76.
3. Open all of the Velcro strips on the cable guide and on the cable guide assembly arm.
4. For each cable, insert the connector end into the system unit first, then route it through the opening in the top-rear of the unit frame ( **E** in Figure 80). You can close the Velcro loop around the cord at this time or later in the cable routing process.

**Tip for routing the mouse, keyboard, and printer cables**

When routing these cables, leave extra length at the connector end by forming a loop either at the connector (see Figure 81) or by coiling it inside the integration tray, before continuing with the cable into the cable guide. This extra length prevents undue strain on the connector.

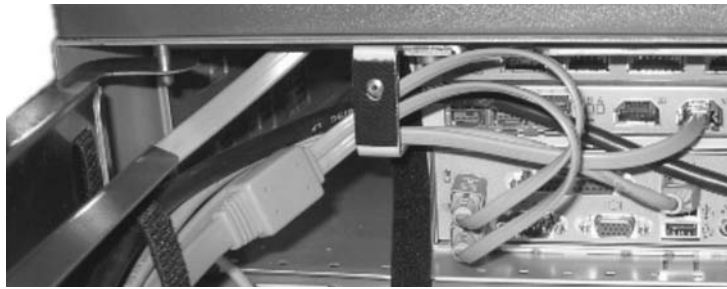

*Figure 81. Extra cord length during routing*

5. With the cable guide arm assembly perpendicular to the system unit, continue to route the cable along the outside of the cable guide arm assembly and along the back of it, closing the Velcro strips where appropriate to secure the cable. You may need to coil excess cable against the back of the cable arm assembly before you close those Velcro strips.

**Note:** At this time, do not plug the power cord into the receptacle or attach the cables to the devices.

6. Ensure that the cables in the cable guide arm assembly are properly secured by freely moving the arm backward and forward. If this action is difficult or impeded, open the Velcro strips and rearrange the cables to create additional slack.



*Figure 82. Cable assembly arm with cables securely in place*

7. Gently close the cable guide assembly arm and lift it behind the small latch on the bottom-right of the unit frame.
8. Attach the rear door (see “Step 3. Installing the covers” on page 31).

---

## Chapter 5. Diagnostics and configuration settings

This chapter provides information on the diagnostics, CMOS, and configuration settings for the SurePOS 700 Models 723, E23, 743, C43, E43, 783, and E83.

### Important information

The SurePOS 700 Models 723, E23, 743, C43, E43, 783, and E83 require new POS I/O and LAN drivers. Existing drivers for Models 4694 and Models 4800 will not work properly with these products. This notice applies to all operating systems: DOS, 4690, Windows, and Linux. Additionally, a hard drive image for a predecessor product will not work properly. Be sure and download the appropriate drivers from the IBM Retail Store Solutions Web site at <http://www.ibm.com/solutions/retail/store>.

---

## Service and diagnostics

The service and diagnostics programs for the SurePOS 700 Models 723, E23, 743, C43, E43, 783, and E83 are available from the IBM Retail Store Solutions Web site at <http://www.ibm.com/solutions/retail/store>.

To run the diagnostics:

1. Download the appropriate diagnostics image from the Web site and copy it to your media.
2. Ensure that your BIOS settings on the terminal are set to permit you to boot from the media for your installation (see "Boot device order" on page 82).
3. Boot your system using the executable file.

---

## Using the IBM BIOS Setup Utility

The IBM BIOS Setup Utility is a program for viewing and configuring system functions. These are some examples of these system functions:

- Setting the system time and date
- Changing the boot device order
- Configuring power management settings
- Setting passwords

The settings controlled by the SurePOS Feature Card program are stored in nonvolatile memory (NVRAM). The default settings for most system functions are acceptable for the majority of environments.

## Navigation and menus

Use an attached PC keyboard to navigate and configure options. Start the IBM BIOS Setup Utility during the POST by pressing the Delete key when the system prompts you to enter setup.

Menus provide configuration of different system functions. Menus preceded by the greater than (>) symbol have submenus. Use the arrow key to navigate the menus, and use the Esc key to exit them. After you select a submenu, press Enter to open it.

## Saving settings

Changes made in the IBM BIOS Setup Utility must be saved so that they can take affect on the next system boot. Exceptions are the time and date, which are updated and saved immediately. To save changes, select **Save & Exit Setup** on the main menu or press **F10** at any time. To exit Setup without saving changes, select **Exit Without Saving** or press **Esc** while at the main menu.

You can save your settings to a file using the CMOS Save Utility and then copy them to other units using the CMOS Restore Utility. These utilities can be downloaded from the IBM Retail Store Solutions Web site at <http://www.ibm.com/solutions/retail/store>.

## Boot device order

The boot device order is a setting that you can configure. This function controls the devices from which the system can be booted and the order in which they are started. This function is located on the Advanced BIOS Features menu as **First Boot Device**, **Second Boot Device**, **Third Boot Device**, and **Fourth Boot Device**. Navigate to each item and press **Enter** to see a list of available boot devices.

The system default is:

- First Boot Device: USB-FDD
- Second Boot Device: CD-ROM
- Third Boot Device: Hard Disk
- Fourth Boot Device: Broadcom PXE

With this setting, the system attempts to boot first from a diskette in a USB diskette drive, then from hard disk drive 0, then from the LAN. If no devices are bootable, the system will repeatedly try the boot list in order until it is successful.

## Restoring CMOS default settings

To clear your CMOS settings and restore the default settings:

**Note:** Be sure to record your customized settings to reset them later.

1. Turn off the system unit and disconnect the AC power cord.
2. Follow the instructions in “Removing the covers” on page 43.
3. Follow the instructions in “Removing the pullout tray” on page 47.
4. See **A** in Figure 83 or **B** in Figure 84 on page 84 to locate your CMOS jumper on the system board. See Table 9 on page 84 for the correct pins and position to clear your CMOS settings.

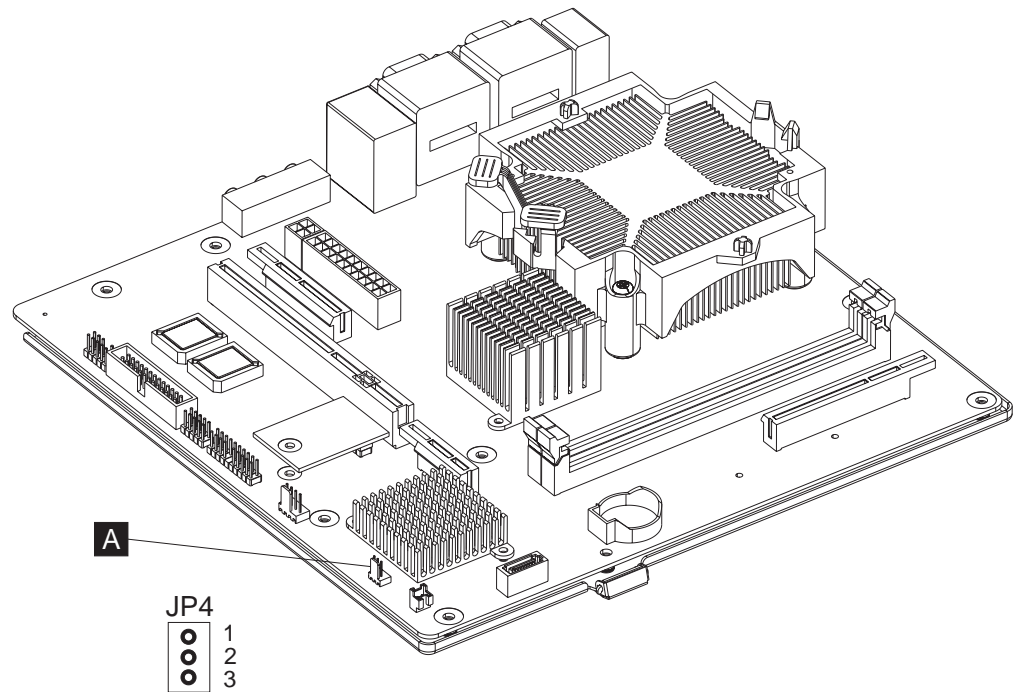

Figure 83. Location of CMOS jumper - Models 743, C43, E43, 783, and E83

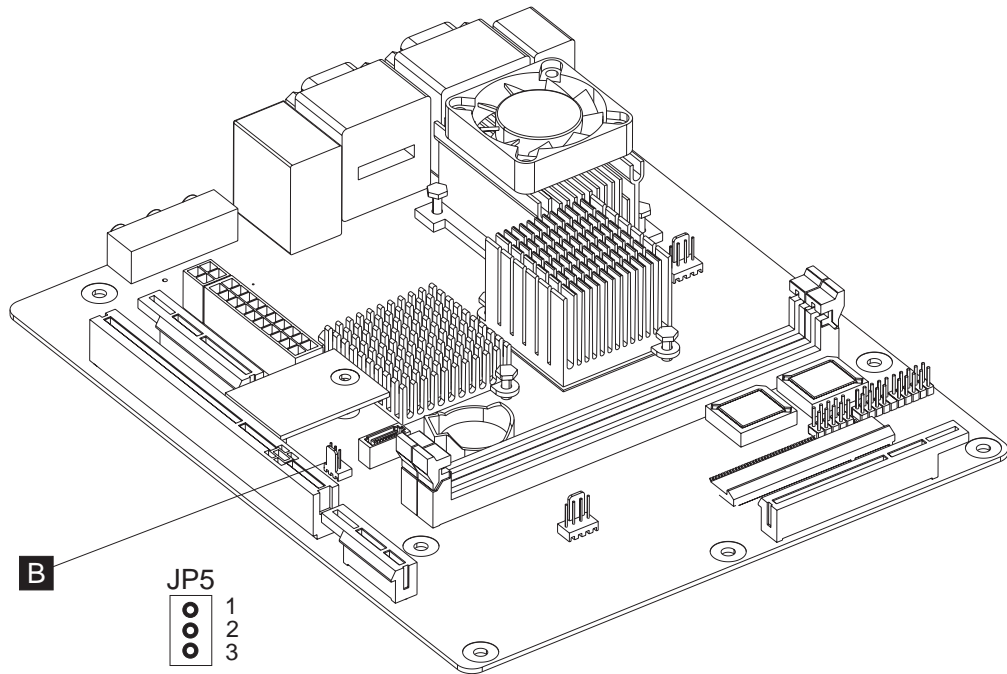

Figure 84. Location of CMOS jumper - Models 723 and E23

Table 9. CMOS jumper and pin location by model

| Model                              | CMOS jumper | Pins for normal operation | Pins to clear CMOS |
|------------------------------------|-------------|---------------------------|--------------------|
| Models 723 and E23                 | JP5         | 1-2                       | 2-3                |
| Models 743, C43, E43, 783, and E83 | JP4         |                           |                    |

5. Move the pins to position 2-3 and wait for five seconds.
6. Return the pins to position 1-2.
7. Plug the AC cord back in and turn on the system. Your system now has the default CMOS settings.

**Note:** Restoring the CMOS default settings might be necessary if a password is lost or forgotten.

## Chapter 6. Operating POS I/O devices

This chapter describes and illustrates the POS I/O devices on the SurePOS 700 and describes how to operate them.

### Displays

Figure 85 shows the available character displays.

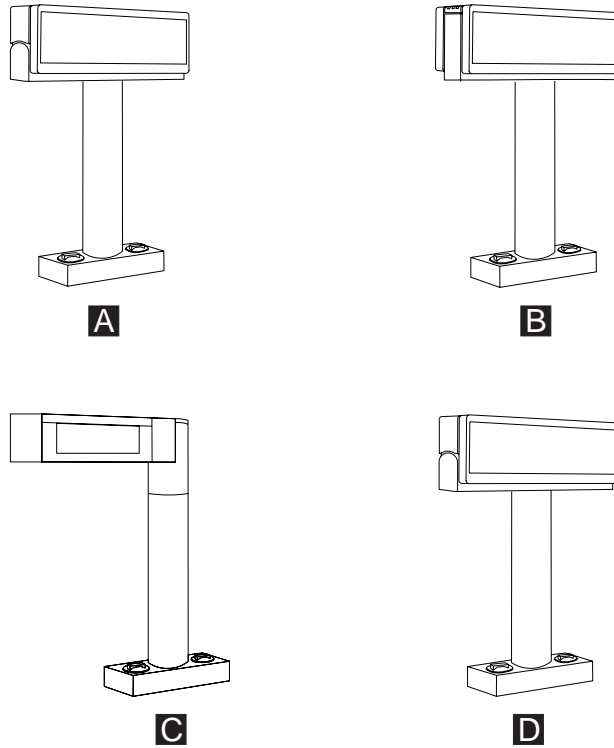

Figure 85. Character displays

- The 40-character VFD ( **A** ) and 40-character LCD ( **C** ) each display two lines of 20 characters per line.
- The 40-character VFD can be configured with a display on two sides ( **B** ).
- The character/graphics display ( **D** ) can display two lines of 20 characters per line in single-byte mode, it can display two lines of 10 characters per line in double-byte mode, and it can display image data at 160 dots (horizontally) by 36 dots (vertically).

You can attach other displays, including the IBM SurePoint Solution display, to the SurePOS 700; however, they must be Plug and Play as defined by Microsoft Corporation.

## Adjusting the controls on video displays

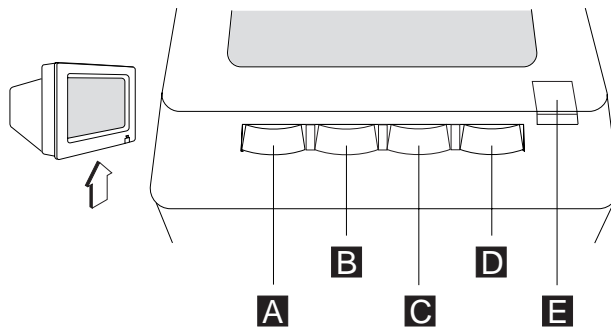

Figure 86. Controls on 9 in. monochrome display

The 9-inch monochrome display has vertical size ( **A** ), horizontal center ( **B** ), contrast ( **C** ), brightness ( **D** ), and a power switch ( **E** ).

## Cash drawers

The cash drawers are similar in size to the system unit and open toward the front. The types of cash drawers are the full-size cash drawer that fits wide system units (see Figure 87), and the compact cash drawer that fits narrow systems (see Figure 88 on page 87). The cash drawers can serve as the base for the terminal in an integrated arrangement, or they can be placed separately in a distributed arrangement. An optional lock permits them to open under an application program control or with a key.

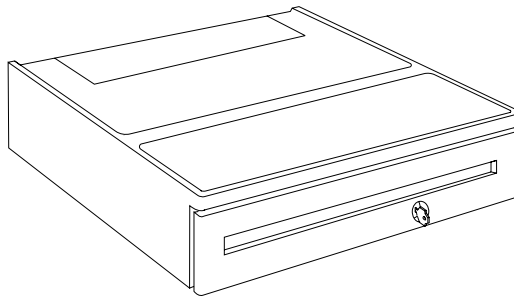

Figure 87. Full-size cash drawer

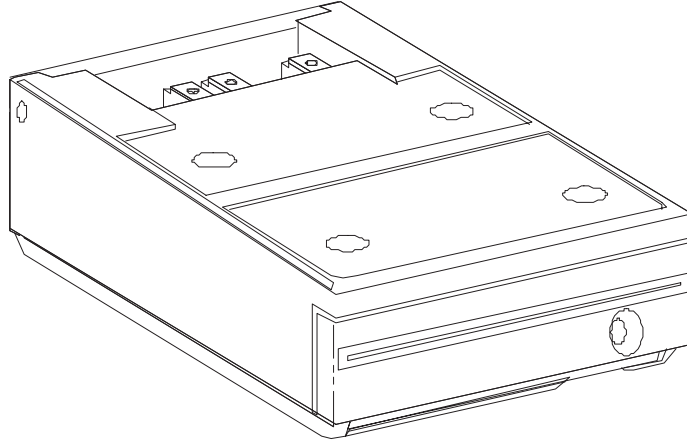

Figure 88. Compact cash drawer

## Lock positions

The cash drawer lock has three positions:



Figure 89. Lock positions

- A** Locked closed
- B** Operate
- C** Manual open/locked open

The Operate position (**B**) permits the cash drawer to open under application program control. The key is normally turned to this position while the terminal is in operation. The key can be removed while in any of the three positions.

## Document storage area under cash drawer

Space is available under the cash drawer for storing documents. Use the slot at the front of the cash drawer for depositing documents without opening the cash drawer. A depth adjustment bar ( **A** in Figure 90) located inside the cash drawer lets you adjust the size of the document storage area to suit your needs.

**Note:** The depth-adjustment bar is not compatible with the vertical till.

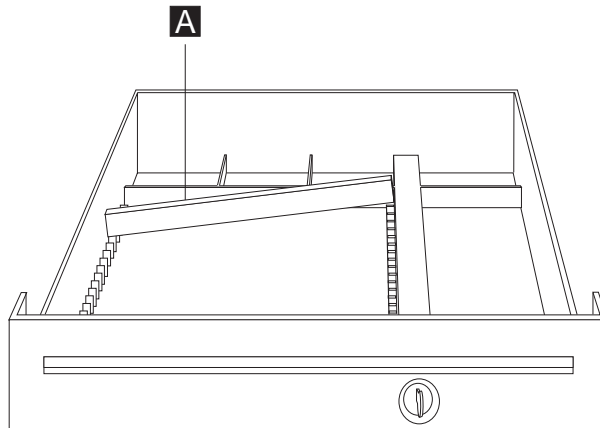

Figure 90. Cash drawer depth-adjustment bar

## Cash drawer options

### Locking till cover

A removable locking cash drawer cover is offered to ensure that contents do not spill or rearrange when transporting or stacking the cash drawer.

### Fixed till (full-size cash drawer)

The fixed till for the full-size cash drawer has five bill and five coin sections in fixed locations.

### Adjustable till (full-size cash drawer)

An adjustable till for the full-size cash drawer is available to fit varying currency. The adjustable cash drawer comes with four bill sections, four coin sections, and five bill-holding clips.

### Vertical till (full-size cash drawer)

Designed for use with European currency, the vertical till for the full-size cash drawer offers eight bill and nine coin sections. The vertical till is arranged to stack paper currency on edge.

### Horizontal till (compact cash drawer)

A horizontal till for the compact cash drawer is available for use with narrow models to fit varying currency. The compact cash drawer comes with three bill sections and four coin sections.

### Vertical till (compact cash drawer)

Designed for use with European currency, the vertical till for the compact cash drawer offers seven bill sections and five coin sections. The vertical till is arranged to stack paper currency on edge.

## Using the cash drawer coin roll cutter (compact cash drawer only)

To use the cash drawer coin roll cutter:

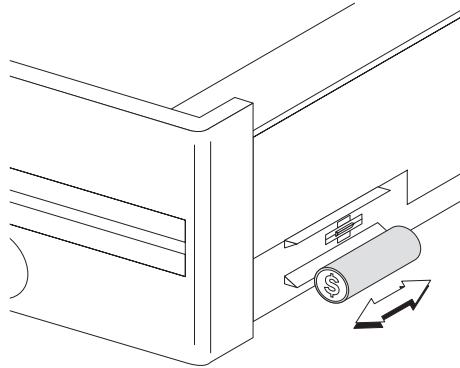

*Figure 91. Using the coin roll cutter*

1. Either push or pull the roll against the coin roll cutter until a score is made in the outside cover.
2. Break the coin roll open with your hands.

## Keyboards

Several kinds of keyboards are available with a variety of features. Most have a built-in magnetic stripe reader (MSR).

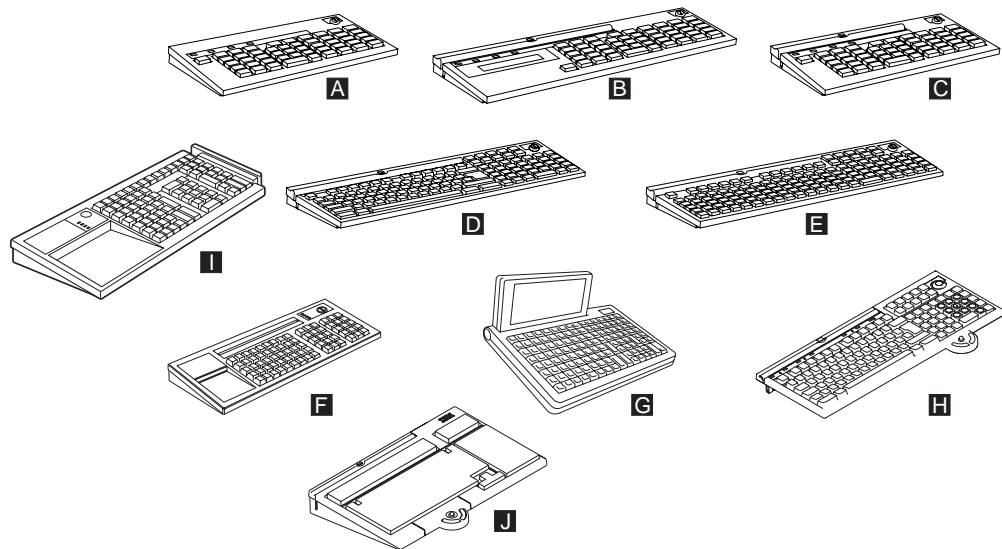

Figure 92. Keyboard types for the SurePOS 700

- A** 50-key keyboard
- B** 50-key keyboard with MSR and display
- C** 50-key keyboard with MSR, or  
50-key keyboard with JUCS MSR
- D** ANPOS keyboard, or  
ANKPOS keyboard
- E** 133-key keyboard with MSR
- F** Keyboard-V
- G** PLU keyboard
- H** PS/2 ANPOS keyboard with integrated pointing device
- I** Keyboard VII
- J** CANPOS keyboard

**Note:** The redesigned cap (with the textured surface) for the keyboard pointing device (joystick) is a consumable item which you are responsible for replacing. If you have this style of cap, you can purchase replacements by calling 1-800-IBM-CALL (1-800-426-2255) in the U.S. and Canada. If you are located outside of the U.S. or Canada then contact your IBM representative. The part number for the cap is 30R0037.

## Manager's lock

The keyboards can be equipped with a manager's lock ( **A** in Figure 93) for special override functions as determined by your store procedures.

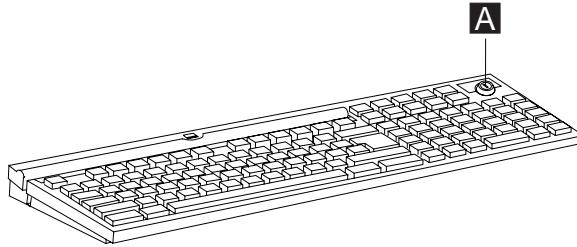

Figure 93. Manager's lock

During normal operations, the lock is in the OFF position. When needed, it can be turned to the ON position to enable special keying functions, and then turned OFF again. The key cannot be removed while it is in the ON position.

## Function keys

Function keys, such as S1 and S2, permit the terminal to perform certain functions or operations with fewer keystrokes by the operator.

On keyboards that have a Control (Ctrl) key, the S1 and S2 functions require a combination of two keys:

1. Press and hold the **Ctrl** key ( **A** in Figure 94).
2. Then, press the **S1** ( **B** ) or the **S2** ( **C** ) key.

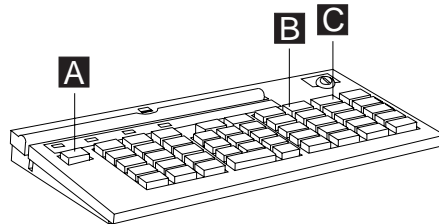

Figure 94. Example of S1 and S2 function keys

If no Ctrl key is present, you need only press the S1 or S2 key. Figure 94 illustrates the keys on a typical keyboard.

**Note:** On the ANPOS keyboard, these keys perform the role of function keys:

- The Escape (ESC) key functions as S1.
- The Enter key functions as S2.

## Keyboard status indicator lights

Four status indicator lights on the keyboard provide information about the system:

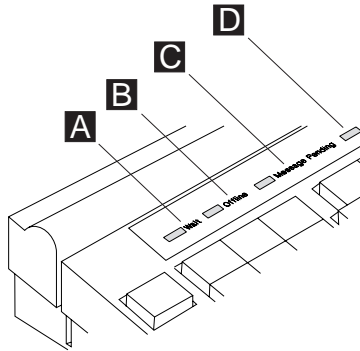

Figure 95. Location of keyboard status-indicator lights

### **A (Wait)**

The application program running on the terminal is waiting for an action to complete (for example, waiting for a program to load).

### **B (Offline)**

Normal online operations have been interrupted and you can display an offline message using system function keys. An offline message gives you information related to the offline condition.

### **C (Message Pending)**

A system message is waiting to be displayed on the terminal, and can be displayed using system function keys.

### **D (Unlabeled)**

(Reserved)

**Note:** The fourth light is unlabeled and not currently used.

The status indicator lights operate under application-program control. Refer to your local operating procedures for specific actions to take when the status indicators are lit.

## Using the USB keyboard-V

The keyboard-V contains various controls, switches, indicators, and features.

### Status indicators

The status indicators show the operating status of the POS terminal. The arrow in Figure 96 shows the location of the indicators.

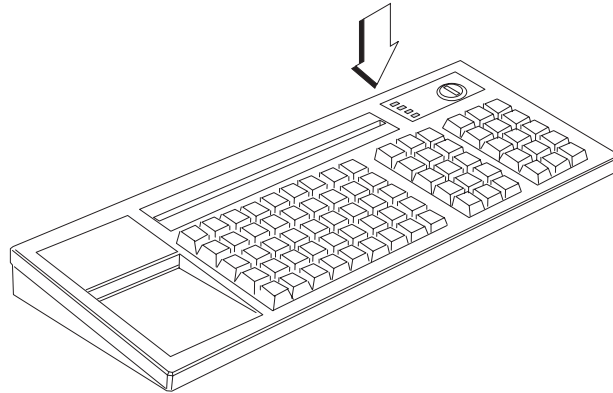

Figure 96. Location of keyboard-V status indicators

**Ready** The IPL has completed and the POS terminal is operational.

**Wait** A process wait condition by the POS terminal exists, such as a program load wait condition. In this situation, the POS terminal continues the processing after the wait condition is cleared. The keyboard is locked and you can only enter system function requests using the system function keys.

### Offline

The POS terminal is operating offline. In this state, the operator can display offline messages by using the system function keys. These messages indicate the offline state of the POS terminal.

### System Message

A system message sent from the system unit is pending display. Press a system function key to display the message.

## Adjusting the keyboard beeper volume

You can adjust the volume of the keyboard beeper to high or low using the volume control located on the rear of the keyboard.

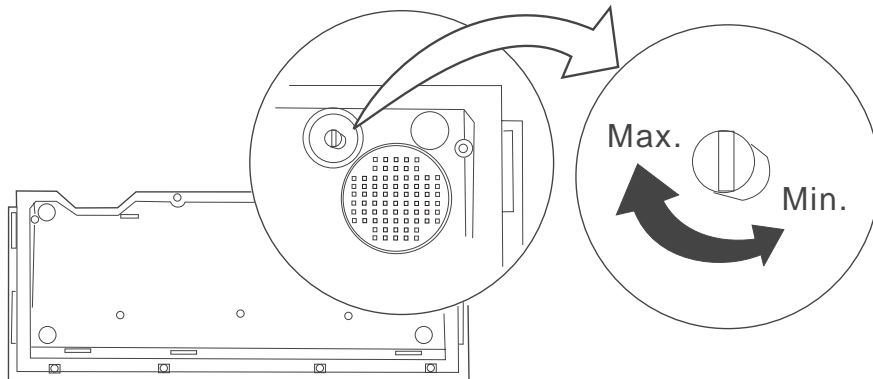

Figure 97. USB keyboard-V volume control

To set the volume to high, turn the knob clockwise. To set the volume to low, turn the knob counterclockwise. IBM recommends that you set the volume to high, because it is cumbersome to change it after you install the keyboard on the POS terminal.

## Using the mode lock key

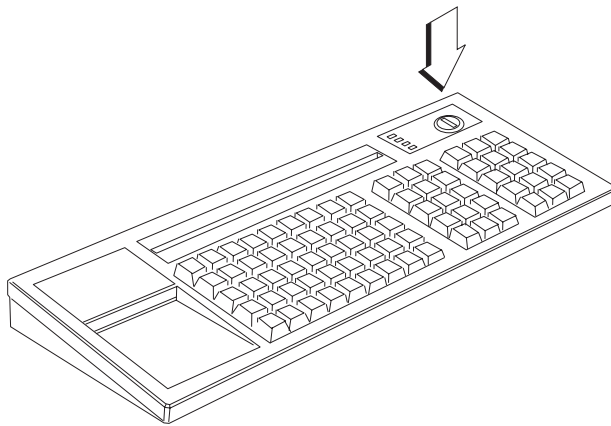

Figure 98. Location of mode lock keys

Use the mode lock key (see the arrow in Figure 98) on the USB keyboard-V to call special functions that have been set for your store. This switch provides two positions for the operator and two positions for the manager.

## Using the system function keys

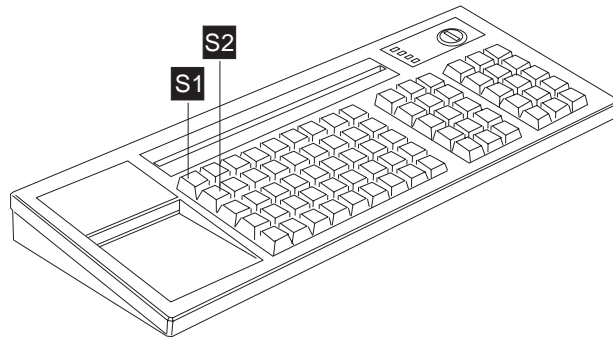

Figure 99. Location of system function keys

Use the system function keys S1 and S2 to start the system-initiated functions. Refer to your local operating procedures or ask your manager for the details of these functions.

## Using the USB PLU keyboard with display

This section describes the features of the USB PLU keyboard with display.

### Status indicators

The status indicators show the operating status of the POS terminal (see the arrow in Figure 100).

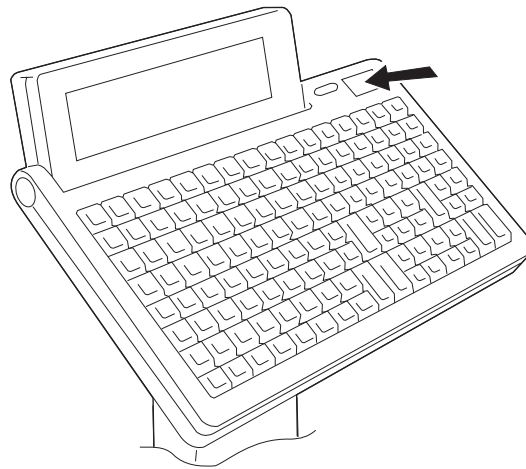

Figure 100. Location of USB PLU keyboard with display indicators

**Ready** The IPL has completed and the POS terminal is operational.

**Wait** A process wait condition by the POS terminal exists, such as program load wait condition. In this situation, the POS terminal continues the processing after the wait condition is cleared. The keyboard is locked and you can only enter system function requests using the system function keys.

### Offline

The POS terminal is operating offline. In this state, the operator can display offline messages by using the system function keys. These messages indicate the offline state of the POS terminal.

**System Message**

A system message sent from the system unit is pending display. Press a system function key to display the message.

**Changing the keyboard beeper tone**

You can adjust the pitch of the USB PLU keyboard with display beeper tone higher or lower using the DIP switches that are located at the bottom left of the PLU keyboard. This feature is useful when setting a tone unique to your keyboard so that you can identify it from other keyboards.

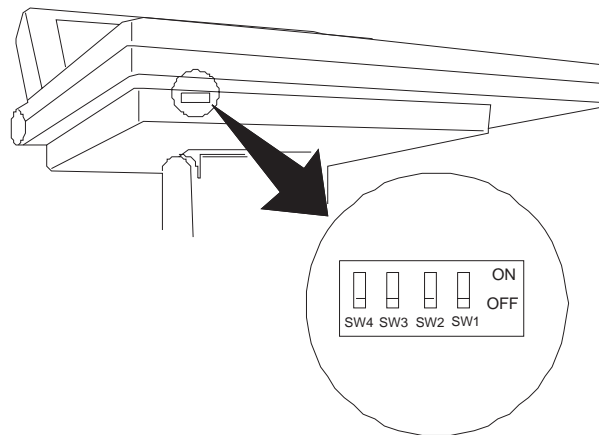

Figure 101. Location of PLU keyboard DIP switches

Table 10. Settings for DIP switches SW3 and SW4

| Tone      | SW3 | SW4 |
|-----------|-----|-----|
| Very Low  | Off | Off |
| Low       | Off | On  |
| High      | On  | Off |
| Very High | On  | On  |

**Adjusting the keyboard beeper volume**

You can adjust the volume (see Figure 102 on page 97) of the USB PLU keyboard with display beeper to high or low using the volume control knob located at the bottom right of the keyboard. To set the volume to high, turn the knob clockwise. To set the volume low, turn the knob counterclockwise. You will need a screwdriver to turn the knob.

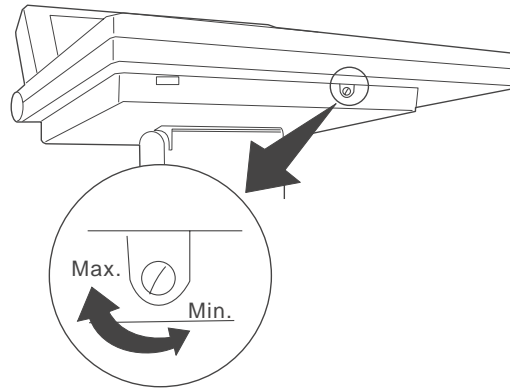

Figure 102. Location of volume control on USB PLU keyboard with display

### Using the system function keys

System function keys are used to start the system-initiated functions.

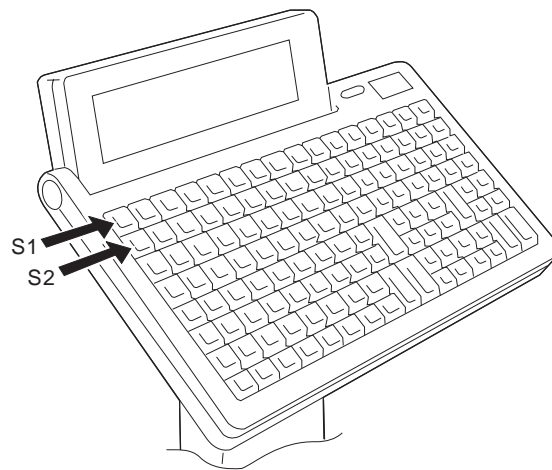

Figure 103. Location of system function keys

See Figure 103 to locate the system function keys S1 and S2. Refer to your local operating procedures or ask your manager for the details of these functions.

---

## Entering data at your terminal

These sections show how to enter sales transaction data at your terminal using the card reader, barcode readers, and scanners.

### Operating card readers

The card reader is also referred to as a magnetic stripe reader (MSR). To enter data:

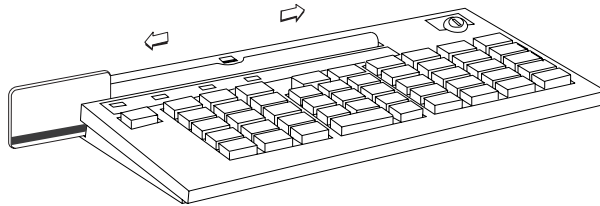

Figure 104. Reading a magnetic stripe card

1. Hold the magnetic stripe card horizontally with the stripe at the bottom and facing you.
2. Place the card in the card reader.
3. With a steady, smooth motion, pass the card through the reader. You can pass the card through the reader in either direction from the left or from the right.

The response you receive is controlled by the application program for your store. If the data was not accepted, verify that the card was inserted correctly. If it was not inserted correctly, turn the card to the correct position. Pass the card through the reader again with a steady, smooth motion.

### Cleaning the card reader

If you are using the card reader correctly and receive a large number of misreads, you might need to clean the read head with an MSR cleaning card. The cleaning card (P/N 6019483) is available through your IBM representative. You should clean the card reader about every 10 000 passes. To clean the card reader:

1. Locate the special cleaning card.
2. Hold the card horizontally with the stripe at the bottom and facing you.
3. Pass the card through the reader several times in either direction, using a smooth, steady motion.

---

## Printers

Refer to the *IBM SureMark 4610 Printers User's Guide* to install and use the IBM 4610 printer.

## Chapter 7. Troubleshooting

Problems with the SurePOS 700 Models 723, E23, 743, C43, E43, 783, and E83 can be caused by software errors or hardware failures. This chapter contains problem-analysis tables to help determine the cause of a problem and how to solve it.

When you turn on the SurePOS 700, the system runs a power on self test (POST). These conditions indicate a successful POST:

- A single beep
- The power and UPS status indicators are both on and not blinking.

If the POST is unsuccessful, see “Problem isolation.”

---

### Preliminary checklist

If you have a problem with the system, first use this checklist:

1. Ensure that all I/O devices are connected correctly.
2. Ensure that AC power is connected.
3. Ensure that the contrast and the brightness controls on the display are adjusted correctly.
4. Ensure that all installed hardware (such as a memory module, feature card, printer, or mouse) and cables are connected correctly and securely.
5. Turn on the system and listen for one or two beeps at the completion of the POST.
6. If POST does not complete, turn off the system and remove any optional adapters and all I/O devices except a single keyboard and display.
7. If POST still fails to complete, see “Problem isolation.”

---

### Problem isolation

If the SurePOS 700 fails, follow the procedures that are described in Table 11. If you cannot solve the problem, contact a trained service technician.

*Table 11. Actions to isolate the cause of a problem*

| <b>Problem</b>                         | <b>Action to perform</b>   |
|--|--|
| The power indicator remains off.       | <ol style="list-style-type: none"> <li>1. Check that the AC power cord is plugged into both the wall outlet and the back of the terminal.</li> <li>2. Ensure that AC power is present at the wall outlet.</li> </ol> |
| There is a continuous series of beeps. | <ol style="list-style-type: none"> <li>1. Check to see if memory is missing.</li> <li>2. Re-seat memory.</li> <li>3. Replace memory.</li> </ol>  |

Table 11. Actions to isolate the cause of a problem (continued)

| Problem  | Action to perform  |
|--|--|
| The video display is failing (totally blank screen, no cursor displayed, screen is unreadable, or other display problems). | <ol style="list-style-type: none"> <li>1. Verify that the video display cables are securely connected.</li> <li>2. Ensure that the video display power cord is plugged in and that the video display is turned on.</li> <li>3. Verify that the power indicator on the system unit and the indicator light on the display are lit.</li> <li>4. Adjust contrast and brightness controls on the display.</li> <li>5. Use the reference documentation (if available) for the display.</li> <li>6. Exchange the video display.</li> </ol> |
| The keyboard does not work or only some keys work.   | <ol style="list-style-type: none"> <li>1. Ensure that the keyboard is securely attached to the keyboard port.</li> <li>2. Move your fingers across the keys. Ensure that no keys are stuck.</li> <li>3. Ensure that you are on a screen that permits typing. Some screens do not permit you to type on them.</li> </ol>  |
| One or more POS I/O devices are failing.   | <ol style="list-style-type: none"> <li>1. Ensure that the I/O devices are securely and correctly connected to the system unit.</li> <li>2. If the device has its own power cord and power switch, ensure that it has power and that the power switch is turned on.</li> <li>3. Exchange the cables.</li> <li>4. If a POS I/O device is available that is known to be good, substitute it for the failing device to help in isolating the failure.</li> </ol>   |
| An optional feature adapter is failing.  | Refer to the service information for the adapter.  |
| The system does not turn off when the power switch is pressed.   | Press and hold the power button until the unit turns off (approximately five seconds).   |

**Notes:**

1. Some devices that attach to the system have test instructions. Refer to those instructions when testing those devices.
2. Record any error message or symptom so that this information is available when service is called.
3. When using application software, you might receive error messages that apply to the software. Refer to the software manual for explanations of those messages.

---

## Appendix A. Safety information



**Danger:**

Before you begin to install this product, read the safety information in *IBM Safety Information — Read This First*, GA27-4004. This booklet describes safe procedures for cabling and plugging in electrical equipment.



**Gevaar:**

Voordat u begint met de installatie van dit product, moet u eerst de veiligheidsinstructies lezen in de brochure *Veiligheidsinstructies—Lees dit eerst*, GA27-4004. Hierin wordt beschreven hoe u elektrische apparatuur op een veilige manier moet bekabelen en aansluiten.



**Perigo:**

Antes de começar a instalar este produto, leia as informações de segurança contidas em *Informações Sobre Segurança—Leia Isto Primeiro*, GA27-4004. Esse folheto descreve procedimentos de segurança para a instalação de cabos e conexões em equipamentos elétricos.



**Fare!**

Før du installerer dette produkt, skal du læse sikkerhedsforskrifterne i *Sikkerhedsforskrifter—Læs dette først* GA27-4004. Vejledningen beskriver den fremgangsmåde, du skal bruge ved tilslutning af kabler og udstyr.



**Gevaar**

Voordat u begint met het installeren van dit produkt, dient u eerst de veiligheidsrichtlijnen te lezen die zijn vermeld in de publikatie *IBM Safety Information — Read This First*, GA27-4004. In dit boekje vindt u veilige procedures voor het aansluiten van elektrische apparatuur.



**VAARA**

Ennen kuin aloitat tämän tuotteen asennuksen, lue julkaisussa *Turvaohjeet—Luetämä ensin*, GA27-4004, olevat turvaohjeet. Tässä kirjasessa on ohjeet siitä, miten sähkölaitteet kaapeloidaan ja kytketään turvallisesti.



**Danger**

Avant d'installer le présent produit, consultez le livret *Informations pour la sécurité—Lisez-moi d'abord*, GA27-4004, qui décrit les procédures à respecter pour effectuer les opérations de câblage et brancher les équipements électriques en toute sécurité.



**Vorsicht**

Bevor mit der Installation des Produktes begonnen wird, die Sicherheitshinweise in *Sicherheitsinformationen—Bitte zuerst lesen*, IBM Form GA27-4004. Diese Veröffentlichung beschreibt die Sicherheitsvorkehrungen für das Verkabeln und Anschließen elektrischer Geräte.



**Vigyázat**

Mielőtt megkezdi a berendezés üzembe helyezését, olvassa el a *IBM Safety Information — Read This First*, GA27-4004 könyvecskeben leírt biztonsági információkat. Ez a könyv leírja, milyen biztonsági intézkedéseket kell megtenni az elektromos berendezés huzalozásakor illetve csatlakoztatásakor.



**Pericolo**

prima di iniziare l'installazione di questo prodotto, leggere le informazioni relative alla sicurezza riportate nell'opuscolo *Informazioni di sicurezza—Prime informazioni da leggere* in cui sono descritte le procedure per il cablaggio ed il collegamento di apparecchiature elettriche.



**Fare**

Før du begynner å installere dette produktet, må du lese sikkerhetsinformasjonen i *Sikkerhetsinformasjon—Les dette først*, GA27-4004 som beskriver sikkerhetsrutinene for kabling og tilkobling av elektrisk utstyr.



**Perigo**

Antes de iniciar a instalação deste produto, leia as informações de segurança *Informações de Segurança—Leia Primeiro*, GA27-4004. Este documento descreve como efectuar, de um modo seguro, as ligações eléctricas dos equipamentos.



**Peligro**

Antes de empezar a instalar este producto, lea la información de seguridad en *Información de Seguridad—Lea Esto Primero, GA27-4004*. Este documento describe los procedimientos de seguridad para cablear y enchufar equipos eléctricos.



**Varning—livsfara**

Innan du börjar installera den här produkten bör du läsa säkerhetsinformationen i dokumentet *Säkerhetsföreskrifter—Läs detta först, GA27-4004*. Där beskrivs hur du på ett säkert sätt ansluter elektrisk utrustning.

危險：安裝本產品之前，請先閱讀  
"IBM Safety Information--Read  
This First" GA27-4004 手冊中所提  
供的安全注意事項。這本手冊將會說明  
使用電器設備的纜線及電源的安全程序。

Opasnost: Prije nego sto počnete sa instalacijom produkta,  
pročitajte naputak o pravilima o sigurnom rukovanju u  
Upozorenje: Pravila o sigurnom rukovanju - Prvo pročitaj ovo,  
GA27-4004. Ovaj privitak opisuje sigurnosne postupke za  
priključivanje kabela i priključivanje na električno napajanje.

**Upozornění:** než zahájíte instalaci tohoto produktu, přečtěte si  
nejprve bezpečnostní informace v pokynech „Bezpečnostní  
informace“ č. GA27-4004. Tato brožurka popisuje bezpečnostní  
opatření pro kabeláž a zapojení elektrického zařízení.

**Κίνδυνος:** Πριν ξεκινήσετε την εγκατάσταση αυτού του προϊόντος,  
διαβάστε τις πληροφορίες ασφάλειας στο φυλλάδιο *IBM Safety  
Information-Read this first, GA27-4004*. Στο φυλλάδιο αυτό  
περιγράφονται οι ασφαλείς διαδικασίες για την καλωδίωση των  
ηλεκτρικών συσκευών και τη σύνδεσή τους στην πρίζα.

危險：導入作業を開始する前に、安全に関する  
小冊子 GA27-4004 の「最初にお読みください」  
(Read This First) の項をお読みください。  
この小冊子は、電気機器の安全な配線と接続の  
手順について説明しています。

위험: 이 제품을 설치하기 전에 반드시  
"주의: 안전 정보-시작하기 전에"  
(GA27-4004) 에 있는 안전 정보를  
읽으십시오.

סכנה : לפני שמתחילים בהתקנת מוצר זה, יש לקרוא את הוראות הבטיחות בחוברת  
Caution: Safety Information - Read This First, GA27-4004  
חוברת זו מתארת את הוראות הבטיחות לחיבור הכבלים ולחיבור לחשמל של ציוד חשמלי.

خطر: قبل عملية بدء تركيب هذا المنتج، قم بقراءة معلومات  
الحمية الموجودة في التحذير: معلومات الحماية - Read This First  
GA27-4004 . يقوم هذا الكتيب بوصف اجراءات الأمان  
لتوصيل الأدوات الكهربائية بالكابلات والمقبس الكهربائي.

## ОПАСНОСТ

Пред да почнете да го инсталирате овој продукт, прочитајте ја информацијата за безбедност:  
"Предупредување: Информација за безбедност: Прочитајте го прво ова", GA27-4004.  
Оваа брошура опишува безбедносни процедури за каблирање и вклучување на електрична опрема.

## Uwaga:

Przed rozpoczęciem instalacji produktu należy zapoznać się z instrukcją: "IBM Safety Information - Read This First", GA27-4004.  
Zawiera ona warunki bezpieczeństwa przy podłączeniu do sieci elektrycznej i eksploatacji.

**ОСТОРОЖНО:** Прежде чем устанавливать этот продукт, прочтите Инструкцию по технике безопасности в документе "Внимание: Инструкция по технике безопасности -- Прочестъ в первую очередь", GA27-4004. В этой брошюре описаны безопасные способы каблирования и подключения электрического оборудования.

Nebezpečenstvo: Pred inštaláciou výrobku si prečítajte bezpečnosté predpisy v  
Výstraha: Bezpečnosté predpisy - Prečítaj ako prvé, GA27-4004. V tejto brožúrke sú opísané bezpečnosté postupy pre pripojenie elektrických zariadení.

Pozor: Preden začnete z instalacijo tega produkta preberite poglavje: "Opozorilo: Informacije o varnem rokovanju-preberi pred uporabo," GA27-4004. To poglavje opisuje pravilne postopke za kabliranje,

## 危險：

開始安裝此產品之前，請先閱讀安全資訊。

## 注意：

請先閱讀 - 安全資訊 GA27-4004

此冊子說明插接電器設備之電纜線的安全程序。

## 危險：

在开始安装本产品之前，请阅读  
**IBM Safety Information - Read This First,**  
**GA27-4004** 中的安全信息。  
此手册描述了如何安全地连接和插拔电气设备。

---

## Appendix B. Notices

This information was developed for products and services offered in the U.S.A.

IBM may not offer the products, services, or features discussed in this document in other countries. Consult your local IBM representative for information on the products and services currently available in your area. Any reference to an IBM product, program, or service is not intended to state or imply that only that IBM product, program, or service may be used. Any functionally equivalent product, program, or service that does not infringe any IBM intellectual property right may be used instead. However, it is the user's responsibility to evaluate and verify the operation of any non-IBM product, program, or service.

IBM may have patents or pending patent applications covering the subject matter in this document. The furnishing of this document does not give you any license to these patents. You can send license inquiries, in writing, to:

IBM Director of Licensing  
IBM Corporation  
North Castle Drive  
Armonk, NY 10504-1785  
U.S.A.

For license inquiries regarding double-byte character set (DBCS) information, contact the IBM Intellectual Property Department in your country or send inquiries, in writing, to:

IBM World Trade Asia Corporation  
Licensing  
2-31 Roppongi 3-chome, Minato-ku  
Tokyo 106, Japan

The following paragraph does not apply to the United Kingdom or any other country where such provisions are inconsistent with local law: INTERNATIONAL BUSINESS MACHINES CORPORATION PROVIDES THIS PUBLICATION "AS IS" WITHOUT WARRANTY OF ANY KIND, EITHER EXPRESS OR IMPLIED, INCLUDING, BUT NOT LIMITED TO, THE IMPLIED WARRANTIES OF NON-INFRINGEMENT, MERCHANTABILITY, OR FITNESS FOR A PARTICULAR PURPOSE. Some states do not allow disclaimer of express or implied warranties in certain transactions, therefore, this statement may not apply to you.

This information could include technical inaccuracies or typographical errors. Changes are periodically made to the information herein; these changes will be incorporated in new editions of the publication. IBM may make improvements and/or changes in the product(s) and/or program(s) described in this publication at any time without notice.

IBM may use or distribute any of the information you supply in any way it believes appropriate without incurring any obligation to you.

Any references in this information to non-IBM Web sites are provided for convenience only and do not in any manner serve as an endorsement of those Web sites. The materials at those Web sites are not part of the materials for this IBM product and use of those Web sites is at your own risk.

Information concerning non-IBM products was obtained from the suppliers of those products, their published announcements or other publicly available sources. IBM has not tested those products and cannot confirm the accuracy of performance, compatibility or any other claims related to non-IBM products. Questions on the capabilities of non-IBM products should be addressed to the suppliers of those products.

This information is for planning purposes only. The information herein is subject to change before the products described become available.

## Electronic emission notices

### Federal Communications Commission (FCC) statement

This equipment has been tested and found to comply with the limits for a Class A digital device, pursuant to Part 15 of the FCC Rules. These limits are designed to provide reasonable protection against harmful interference when the equipment is operated in a commercial environment. This equipment generates, uses, and can radiate radio frequency energy and, if not installed and used in accordance with the instruction manual, may cause harmful interference to radio communications. Operation of this equipment in a residential area is likely to cause harmful interference, in which case the user will be required to correct the interference at his own expense.

Properly shielded and grounded cables and connectors must be used in order to meet FCC emission limits. IBM is not responsible for any radio or television interference caused by using other than recommended cables and connectors or by unauthorized changes or modifications to this equipment. Unauthorized changes or modifications could void the user's authority to operate the equipment.

This device complies with part 15 of the FCC Rules. Operation is subject to the following two conditions:

1. This device may not cause harmful interference, and
2. This device must accept any interference received, including interference that may cause undesired operation.

### European Union EMC Directive conformance statement

This product is in conformity with the protection requirements of EU Council Directive 2004/108/EC on the approximation of the laws of the Member States relating to electromagnetic compatibility. IBM cannot accept responsibility for any failure to satisfy the protection requirements resulting from a non-recommended modification of the product, including the fitting of non-IBM option cards.

This product has been tested and found to comply with the limits for Class A Information Technology Equipment according to CISPR 22/European Standard EN 55022. The limits for Class A equipment were derived for commercial and industrial environments to provide reasonable protection against interference with licensed communication equipment.

**Attention:** This is a Class A product. In a domestic environment this product may cause radio interference in which case the user may be required to take adequate measures.

European Community contact:

IBM Technical Regulations  
Pascalstr. 100, Stuttgart, Germany 70569  
Telephone: 0049 (0)711 785 1176  
Fax: 0049 785 1283  
E-mail: tjahn@de.ibm.com

## Industry Canada Class A Emission Compliance statement

This Class A digital apparatus complies with Canadian ICES-003.

## Avis de conformité aux normes d'Industrie Canada

Cet appareil numérique de la classe A est conforme à la norme NMB-003 du Canada.

## Germany

**Zulassungsbescheinigung laut dem Deutschen Gesetz über die elektromagnetische Verträglichkeit von Geräten (EMVG) vom 30. August 1995 (bzw. der EMC EG Richtlinie 89/336).**

Dieses Gerät ist berechtigt in Übereinstimmung mit dem Deutschen EMVG das EG-Konformitätszeichen - CE - zu führen.

Verantwortlich für die Konformitätserklärung nach Paragraph 5 des EMVG ist die IBM Deutschland Informationssysteme GmbH, 70548 Stuttgart

Informationen in Hinsicht EMVG Paragraph 3 Abs. (2) 2:

|  |
|--|
| Das Gerät erfüllt die Schutzanforderungen nach EN 50082-1 und EN 55022 Klasse A. |
|--|

EN 55022 Klasse A Geräte müssen mit folgendem Warnhinweis versehen werden:

"Warnung: dies ist eine Einrichtung der Klasse A. Diese Einrichtung kann im Wohnbereich Funkstörungen verursachen; in diesem Fall kann vom Betreiber verlangt werden, angemessene Maßnahmen durchzuführen und dafür aufzukommen."

EN 50082-1 Hinweis:

"Wird dieses Gerät in einer industriellen Umgebung betrieben (wie in EN 50082-2 festgelegt), dann kann es dabei eventuell gestört werden. In solch einem Fall ist der Abstand bzw. die Abschirmung zu der industriellen Störquelle zu vergrößern."

Anmerkung:

Um die Einhaltung des EMVG sicherzustellen sind die Geräte, wie in den IBM Handbüchern angegeben, zu installieren und zu betreiben.

## Australia and New Zealand

**Attention:** This is a Class A product. In a domestic environment this product may cause radio interference, in which case the user may be required to take adequate measures.

## Chinese Class A warning statement

**Attention:** This is a Class A product. In a domestic environment this product may cause radio interference in which case the user may be required to take adequate measures.

### 中华人民共和国“A类”警告声明

#### 声 明

此为 A 级产品，在生活环境中，该产品可能会造成无线电干扰。在这种情况下，可能需要用户对其干扰采取切实可行的措施。

## Japanese power line harmonics compliance statement

高調波ガイドライン適合品

高調波ガイドライン適合品

## Japanese Voluntary Control Council for Interference (VCCI) statement

**Attention:** This product is a Class A Information Technology Equipment and conforms to the standards set by the Voluntary Control Council for Interference by Technology Equipment (VCCI). In a domestic environment this product may cause radio interference in which case the user may be required to take adequate measures.

この装置は、情報処理装置等電波障害自主規制協議会（VCCI）の基準に基づくクラスA情報技術装置です。この装置を家庭環境で使用すると電波妨害を引き起こすことがあります。この場合には使用者が適切な対策を講ずるよう要求されることがあります。

## Korean communications statement

Please note that this device has been approved for business purposes with regard to electromagnetic interference. If you find this is not suitable for your use, you may exchange it for a non-business purpose one.

### A급 기기(업무용)

이 기기는 업무용으로 전자파적합등록을 받은 기기이오니 판매자 또는 이용자는 이점을 주의하시기 바라며, 만약 구입하였을 때에는 구입한 곳에서 가정용으로 교환하시기 바랍니다.

## Taiwanese Class A warning statement

警告使用者：  
這是甲類的資訊產品，在  
居住的環境中使用時，可  
能會造成射頻干擾，在這  
種情況下，使用者會被要  
求採取某些適當的對策。

---

## Taiwan contact information

台灣IBM 產品服務聯絡方式：  
台灣國際商業機器股份有限公司  
台北市松仁路7號3樓  
電話：0800-016-888

IBM Taiwan Product Service Contact Info:  
IBM Taiwan Corporation  
3F, No 7, Song Ren Road, Taipei Taiwan  
Telephone: 0800-016-888

---

## Cable ferrite requirement

All cable ferrites are required to suppress radiated EMI emissions and must not be removed.

---

## Electrostatic Discharge (ESD)

**Attention:** ESD damage can occur when there is a difference in charge between the part, the product, and the service person. No damage will occur if the service person and the part being installed are at the same charge level.

## ESD Damage Prevention

Anytime a service action involves physical contact with logic cards, modules, back-panel pins, or other ESD sensitive (ESDS) parts, the service person must be connected to an ESD common ground point on the product through the ESD wrist strap and cord.

The ESD ground clip can be attached to any frame ground, ground braid, green wire ground, or the round ground prong on the AC power plug. Coax or connector outside shells can also be used.

## Handling Removed Cards

Logic cards removed from a product should be placed in ESD protective containers. No other object should be allowed inside the ESD container with the logic card. Attach tags or reports that must accompany the card to the outside of the container.

---

## Product Recycling and disposal

This unit must be recycled or discarded according to applicable local and national regulations. IBM encourages owners of information technology (IT) equipment to responsibly recycle their equipment when it is no longer needed. IBM offers a variety of product return programs and services in several countries to assist equipment owners in recycling their IT products. Information on IBM product recycling offerings can be found on IBM's Internet site at <http://www.ibm.com/ibm/environment/products/prp.shtml>.

Español:

Esta unidad debe reciclarse o desecharse de acuerdo con lo establecido en la normativa nacional o local aplicable. IBM recomienda a los propietarios de equipos de tecnología de la información (TI) que reciclen responsablemente sus equipos cuando éstos ya no les sean útiles. IBM dispone de una serie de programas y servicios de devolución de productos en varios países, a fin de ayudar a los propietarios de equipos a reciclar sus productos de TI. Se puede encontrar información sobre las ofertas de reciclado de productos de IBM en el sitio web de IBM <http://www.ibm.com/ibm/environment/products/prp.shtml>.



**Notice:** This mark applies only to countries within the European Union (EU) and Norway.

Appliances are labeled in accordance with European Directive 2002/96/EC concerning waste electrical and electronic equipment (WEEE). The Directive determines the framework for the return and recycling of used appliances as applicable throughout the European Union. This label is applied to various products to indicate that the product is not to be thrown away, but rather reclaimed upon end of life per this Directive.

In accordance with the European WEEE Directive, electrical and electronic equipment (EEE) is to be collected separately and to be reused, recycled, or recovered at end of life. Users of EEE with the WEEE marking per Annex IV of the

WEEE Directive, as shown above, must not dispose of end of life EEE as unsorted municipal waste, but use the collection framework available to customers for the return, recycling, and recovery of WEEE. Customer participation is important to minimize any potential effects of EEE on the environment and human health due to the potential presence of hazardous substances in EEE. For proper collection and treatment, contact your local IBM representative.

Disposal of IT products should be in accordance with local ordinances and regulations.

---

## Battery return program

This product may contain sealed lead acid, nickel cadmium, nickel metal hydride, lithium, or lithium ion battery. Consult your user manual or service manual for specific battery information. The battery must be recycled or disposed of properly. Recycling facilities may not be available in your area. For information on disposal of batteries outside the United States, go to <http://www.ibm.com/ibm/environment/products/batteryrecycle.shtml> or contact your local waste disposal facility.

In the United States, IBM has established a return process for reuse, recycling, or proper disposal of used IBM sealed lead acid, nickel cadmium, nickel metal hydride, and other battery packs from IBM equipment. For information on proper disposal of these batteries, contact IBM at 1-800-426-4333. Please have the IBM part number listed on the battery available prior to your call.

### For Taiwan:



Please recycle batteries.

### For the European Union:



**Notice:** This mark applies only to countries within the European Union (EU)

Batteries or packaging for batteries are labeled in accordance with European Directive 2006/66/EC concerning batteries and accumulators and waste batteries and accumulators. The Directive determines the framework for the return and recycling of used batteries and accumulators as applicable throughout the European Union. This label is applied to various batteries to indicate that the battery is not to be thrown away, but rather reclaimed upon end of life per this Directive.

In accordance with the European Directive 2006/66/EC, batteries and accumulators are labeled to indicate that they are to be collected separately and recycled at end of life. The label on the battery may also include a chemical symbol for the metal concerned in the battery (Pb for lead, Hg for mercury and Cd for cadmium). Users of batteries and accumulators must not dispose of batteries and accumulators as unsorted municipal waste, but use the collection framework available to customers for the return, recycling and treatment of batteries and accumulators. Customer participation is important to minimize any potential effects of batteries and accumulators on the environment and human health due to the potential presence of hazardous substances. For proper collection and treatment, contact your local IBM representative.

## For California:

### Perchlorate material – special handling may apply

Refer to <http://www.dtsc.ca.gov/hazardouswaste/perchlorate>.

The foregoing notice is provided in accordance with *California Code of Regulations Title 22, Division 4.5, Chapter 33: Best Management Practices for Perchlorate Materials*. This product/part includes a lithium manganese dioxide battery which contains a perchlorate substance.

---

## Flat panel displays

The fluorescent lamp in the liquid crystal display contains mercury. Dispose of it as required by local ordinances and regulations.

---

## Monitors

Connecticut - Please see the web site of the Department of Environmental Protection at <http://www.ct.gov/dep> for information about recycling covered electronic devices in the State of Connecticut, or telephone the Connecticut Department of Environmental Protection at 1-860-424-3000.

Washington - Please see the web site of the Department of Ecology at <http://1800recycle.wa.gov/> for information about recycling covered electronic devices in the State of Washington, or telephone the Washington Department of Ecology at 1-800Recycle.

---

## Trademarks

The following are trademarks of International Business Machines Corporation in the United States or other countries, or both:

AnyPlace Kiosk(tm)  
AnyPlace POS Hub(tm)  
DB2  
DB2 Universal Database  
IBM and the IBM logo  
PS/2  
SureMark  
SurePoint  
SurePOS  
Wake on LAN  
WebSphere

Microsoft, Windows, Windows NT, and the Windows logo are trademarks of Microsoft Corporation in the United States, other countries, or both.

Celeron and Intel are trademarks of Intel corporation in the United States, or other countries.

Java and all Java-based trademarks and logos are trademarks or registered trademarks of Sun Microsystems, Inc. in the United States, or other countries, or both.

Other company, product, or service names may be trademarks or service marks of others.

---

## Appendix C. Intel software license agreement (final, single user)

The following agreement covers the Ethernet/PXE software used with Intel chips in Retail Store System products that are distributed by IBM:

---

### Important - read before copying, installing or using

Do not use or load this software and any associated materials (collectively, the "Software") until you have carefully read the following terms and conditions. By loading or using the Software, you agree to the terms of this Agreement. If you do not wish to so agree, do not install or use the Software.

### Copyright license

You may copy the Software onto a single computer for your use, and you may make one backup copy of the Software, subject to these conditions:

1. You may not copy, modify, rent, sell, distribute, or transfer any part of the Software except as provided in this Agreement; and you agree to prevent unauthorized copying of the Software.
2. You may not reverse engineer, decompile, or disassemble the Software.
3. You may not sublicense or permit simultaneous use of the Software by more than one user.
4. The Software may contain the software or other property of third party suppliers, some of which may be identified in, and licensed in accordance with, any enclosed "license.txt" file or other text or file.

### Ownership of software and copyrights

Title to all copies of the Software remains with Intel or its suppliers. The Software is copyrighted and protected by the laws of the United States and other countries, and by international treaty provisions. You may not remove any copyright notices from the Software. Intel may make changes to the Software, or to items referenced therein, at any time without notice, but is not obligated to support or update the Software. Except as otherwise expressly provided, Intel grants no express or implied right under Intel patents, copyrights, trademarks, or other intellectual property rights. You may transfer the Software only if the recipient agrees to be fully bound by these terms and if you retain no copies of the Software.

### Limited media warranty

If the Software has been delivered by Intel on physical media, Intel warrants the media to be free from material physical defects for a period of ninety days after delivery by Intel. If such a defect is found, return the media to Intel for replacement or alternate delivery of the Software as Intel may select.

### Exclusion of other warranties

Except as provided above, the software is provided "as is" without any express or implied warranty of any kind including warranties of merchantability, noninfringement, or fitness for a particular purpose.

Intel does not warrant or assume responsibility for the accuracy or completeness of any information, text, graphics, links, or other items contained within the Software.

## **Limitation of liability**

In no event shall Intel or its suppliers be liable for any damages whatsoever (including, without limitation, lost profits, business interruption, or lost information) arising out of the use of or inability to use the software, even if Intel has been advised of the possibility of such damages. Some jurisdictions prohibit exclusion or limitation of liability for implied warranties or consequential or incidental damages, so the above limitation may not apply to you. You may also have other legal rights that vary from jurisdiction to jurisdiction.

## **Termination of this agreement**

Intel may terminate this Agreement at any time if you violate its terms. Upon termination, you will immediately destroy the Software or return all copies of the Software to Intel.

## **Applicable laws**

Claims arising under this Agreement shall be governed by the laws of California, excluding its principles of conflict of laws and the United Nations Convention on Contracts for the Sale of Goods. You may not export the Software in violation of applicable export laws and regulations. Intel is not obligated under any other agreements unless they are in writing and signed by an authorized representative of Intel.

## **Government restricted rights**

The Software is provided with "restricted rights." Use, duplication, or disclosure by the Government is subject to restrictions as set forth in FAR52.227-14 and DFAR252.227-7013 et seq. or its successor. Use of the Software by the Government constitutes acknowledgment of Intel's proprietary rights therein. Contractor or Manufacturer is

Intel Corporation, 2200 Mission College Blvd., Santa Clara, CA 95052

---

# Index

## Numerics

- 40-character character/graphics display, installing 67
- 40-character LCD, installing 62
- 40-character VFD, installing 64

## A

- accessibility of publications xii
- ANPOS keyboard, S1 and S2 functions 91
- audio and headphones 4
- autoexec.bat file 21
- autosensing cash drawers 17

## B

- battery return program 114
- battery, European Union 114
- beep indicators
  - continuous series 99
  - single 99
- BIOS setup program 81
  - boot device order 82
  - navigation menus 82
  - saving settings 82
- BIOS, upgradeable 20

## C

- cable ferrite requirement 112
- cables, installing 51
- calling for service 22
- card reader, cleaning 98
- card reader, operating 98
- cash drawer
  - document storage area 88
  - options 88
  - setting the jumper override 17
  - voltage settings 17
- cash drawer and the system unit, installing 54
- cash drawers
  - operating 86
- cash drawers, autosensing 17
- characteristics
  - physical 6
- Class A compliance statement
  - Australia and New Zealand 110
  - China 111
  - European Union 109
  - FCC (USA) 109
  - Germany 110
  - Industry Canada 110
  - Japan 111
  - Taiwan 112
- clearance, vents 11
- CMOS default settings, restoring 83
- coin roll cutter
  - installing 57

- coin roll cutter (*continued*)
  - operating 89
- compatibility, hardware and software 20
- config.sys file 21
- configuration 23
- configuration settings and diagnostics 81
- connections
  - IBM SurePorts 9
- connectors
  - front panel 7
  - rear panel 7
- controls
  - displays 85
  - front panel 6
- cooling 11
- cover removal 43

## D

- damage from electrostatic discharge 112
- DASD, optional USB 5
- data, entering 98
- default settings, restoring CMOS 83
- devices, I/O 16
- diagnostics and configuration settings 81
- dimensions 6
- displays
  - adjusting controls 85
  - operating 85
- disposal of equipment 113
- document storage area 88
- DOS migration 21
- driver and system support 20
- drivers, downloading 20

## E

- electronic emissions notices 109
  - Australia and New Zealand 110
  - China 111
  - European Union 109
  - FCC (USA) 109
  - Germany 110
  - Industry Canada 110
  - Japan 111
  - Korea 111
  - Taiwan 112
- electrostatic discharge (ESD) 112
- end of life disposal 113
- entering data 98
- environment 11
- equipment disposal 113
- external options, installing 51

**F**

- features
  - optional 2
  - standard 2
- ferrite requirement 112
- fillers, installing 59
- flat panel displays 115
- front lock 43
- front panel
  - connectors 7
  - controls and indicators 6
- function keys 91

**G**

- guidance label, installing 71

**H**

- hardware compatibility 20
- headphones, audio and 4

**I**

- I/O 5
- I/O devices 16
- I/O trays, installing 58
- IBM SurePoint Solution, installing 71
- IBM SurePorts 9
- indicators
  - front panel 6
  - keyboards 92
- installation and setup
  - before you begin 23
  - supported OSes 23
- installation and system setup 23
- installing 23
  - 40-character character/graphics display 67
  - 40-character LCD 62
  - 40-character VFD 64
  - cables 51
  - cash drawer and the system unit 54
  - coin roll cutter 57
  - external options 51
  - feature card 48
  - fillers 59
  - guidance label 71
  - I/O trays 58
  - IBM SurePoint Solution 71
  - internal options 42
  - keyboard-V 75
  - lock inserts 72
  - memory modules 49
  - PLU keyboard 75
  - printer 61
  - riser card 48
  - SurePoint Solution 71
  - tape-holder 60
  - vertical stand 75
- Intel software license agreement 116

- internal options, installing 42

**J**

- Japanese power line harmonics compliance
  - statement 111
- Japanese Voluntary Control Council for Interference
  - statement 111

**K**

- keyboard-V, installing 75
- keyboard-V, operating 93
- keyboard-V, S1 and S2 functions 94
- keyboards
  - ANPOS, S1 and S2 functions 91
  - function keys 91
  - indicators 92
  - manager's lock 91
  - status 92
  - types 90
- Korean communications statement 111

**L**

- Linux migration 21
- local area network 4
- lock inserts, installing 72
- lock inserts, removing 74
- lock positions 87

**M**

- manager's lock 91
- memory, system 3
- mercury-added statement 115
- migration 21
  - DOS 21
  - Linux 21
  - Windows 21
- model descriptions 1
- MSR, cleaning 98
- MSR, operating 98

**N**

- non-POS I/O devices, support for 19
- notices 101, 107
  - battery recycling 114
  - cable ferrites 112
  - electronic emissions 109
  - electrostatic discharge (ESD) 112
  - end of life disposal 113
  - IBM 107
  - Intel 116

**O**

- operating
  - card reader 98

operating (*continued*)

- cash drawers 86
- coin roll cutter 89
- display controls 85
- displays 85
- front lock 43
- keyboard-V 93
- MSR 98
- point-of-sale I/O devices 85
- USB PLU keyboard with display 95
- operating system, supported 20
- optional features 2
- optional USB DASD 5
- overview
  - system i

## P

- password
  - resetting 83
- PC I/O 5
- perchlorate 115
- physical characteristics 6
- PLU keyboard, installing 75
- point-of-sale I/O devices
  - operating 85
- power
  - specifications 12
- power management 14
- power switch operation 13
- powered USB connectors 18
- printer 98
- printer, installing 61
- printers
  - location of printer jumper on I/O card 18
  - voltage 18
- problem isolation 99
- processor, service 3
- program, BIOS setup 81

## R

- RAID 21
- rear panel
  - connectors 7
- Redundant Array of Independent Disks 21
- removal and replacement procedures
  - covers 43
  - feature card 48
  - front bezel 43
  - memory modules 49
  - pullout tray 47
  - riser card 48
  - top cover 43
- removing
  - lock inserts 74
- resetting password 83
- restoring CMOS default settings 83

## S

- safety information 101
- service processor 3
- service, calling 22
- settings, diagnostics and configuration 81
- setup procedures 23
- setup program, BIOS 81
- software compatibility 21
- software interface, unique 5
- software license agreement, Intel 116
- specifications i
  - connectors 7
  - controls and indicators 6
  - dimensions 6
  - power 12
  - UPS 14
- standard features 2
- support, USB 5
- SurePoint Solution, installing 71
- system and driver support 20
- system memory 3
- system overview i
- system setup and installation 23
- system, testing 98

## T

- Taiwanese battery recycling statement 114
- tape-holder, installing 60
- temperature 11
- testing 98
  - preliminary checklist 99
  - problem isolation 99
- trademarks 115
- troubleshooting 98
  - preliminary checklist 99
  - problem isolation 99

## U

- unique software interface 5
- UPS
  - battery life 14
  - configuration (DIP) switches 16
  - host-dependent mode 16
  - input voltage 14
  - specifications 14
  - stand-alone mode 16
  - system unit interface 15
- USB DASD, optional 5
- USB PLU keyboard with display, operating 95
- USB PLU keyboard with display, S1 and S2
  - functions 97
- USB support 5

## V

- vents clearance 11
- vertical stand, installing 75
- video function 3

## **W**

Windows migration 21

---

# Readers' Comments — We'd Like to Hear from You

**SurePOS 700 Series**  
**SurePOS 700-723/743/783 Systems, Installation, and Operations Guide**

**Publication No. GA27-4998-00**

We appreciate your comments about this publication. Please comment on specific errors or omissions, accuracy, organization, subject matter, or completeness of this book. The comments you send should pertain to only the information in this manual or product and the way in which the information is presented.

For technical questions and information about products and prices, please contact your IBM branch office, your IBM business partner, or your authorized remarketer.

When you send comments to IBM, you grant IBM a nonexclusive right to use or distribute your comments in any way it believes appropriate without incurring any obligation to you. IBM or any other organizations will only use the personal information that you supply to contact you about the issues that you state on this form.

Comments:

Thank you for your support.

Submit your comments using one of these channels:

- Send your comments to the address on the reverse side of this form.

If you would like a response from IBM, please fill in the following information:

\_\_\_\_\_

Name

\_\_\_\_\_

Address

\_\_\_\_\_

Company or Organization

\_\_\_\_\_

Phone No.

\_\_\_\_\_

E-mail address



Fold and Tape

Please do not staple

Fold and Tape



NO POSTAGE  
NECESSARY  
IF MAILED IN THE  
UNITED STATES

# BUSINESS REPLY MAIL

FIRST-CLASS MAIL PERMIT NO. 40 ARMONK, NEW YORK

POSTAGE WILL BE PAID BY ADDRESSEE

IBM Corporation  
Retail Store Solutions Information Development, Dept ZBDA  
P. O. Box 12195  
RESEARCH TRIANGLE PARK NC 27709-9990

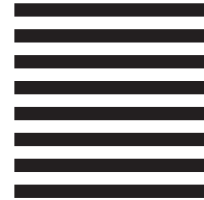

Fold and Tape

Please do not staple

Fold and Tape





October 31, 2007  
Printed in USA

GA27-4998-00

