

Point of Sale



Options and I/O Devices Service Guide

Point of Sale



Options and I/O Devices Service Guide

Note

Before using this information and the product it supports, be sure to read the general information in Appendix B, "Notices," on page 125 and Appendix C, "Safety information," on page 133.

First Edition (June 2006)

This edition applies to all IBM Store Systems that support options and input/output (I/O) devices.

Current versions of Retail Store Solutions documentation are available on the IBM Retail Store Solutions Web site at <http://www.ibm.com/solutions/retail/store/support/>. Click **Publications**.

A form for reader's comments is also provided at the back of this publication. If the form has been removed, address your comments to:

IBM Corporation
Retail Store Solutions Information Development
Department ZBDA
PO Box 12195
Research Triangle Park, North Carolina 27709 USA

When you send information to IBM, you grant IBM a nonexclusive right to use or distribute whatever information you supply in any way it believes appropriate without incurring any obligation to you.

© **Copyright International Business Machines Corporation 2006, 2007. All rights reserved.**

US Government Users Restricted Rights – Use, duplication or disclosure restricted by GSA ADP Schedule Contract with IBM Corp.

Contents

Figures	vii
Tables	ix
About this guide	xi
Who should use this guide	xi
How this guide is organized	xi
Related publications	xi
Summary of Changes	xiii
Providing feedback.	xv
Chapter 1. Diagnostics, tests, and procedures.	1
Determining the problem.	1
Standalone tests.	2
Chapter 2. Point-of-sale cash drawers	3
Connecting non-IBM cash drawers	4
Cash drawer messages	4
Cash drawer symptoms	5
Service procedures for full-size cash drawers	6
Removing and replacing the cash drawer (full-size)	6
Removing and replacing the slide assembly (full-size)	7
Removing and replacing the slanted cash drawer I/O tray (full-size)	8
Installing filler panels (full-size)	8
Fillers for character/graphics display and printer (Japan only)	11
Service procedures for compact cash drawers	12
Removing and replacing the cash drawer (compact)	12
Removing and replacing the slide latches (compact)	13
Removing and replacing the slide assembly (compact)	14
Removing and replacing the rollers (compact)	15
Removing and replacing the coin-roll cutter (compact)	16
Removing and replacing the security clip (compact)	17
Service procedures for cash drawers (all sizes)	17
Removing and replacing the top cover (all sizes)	18
Removing and replacing the latch and sensor assembly (all sizes)	18
Removing and replacing components of the latch and sensor assembly (all sizes)	19
Removing and replacing the lock assembly (all sizes)	20
Removing and replacing the lock insert	21
Removing and replacing the blank lock insert.	22
Chapter 3. Point-of-sale displays	23
Display symptoms.	23
Service procedures for 40-character VFD	24
Removing and replacing the 40-character VFD	24
Removing, replacing, and cleaning the VFD lens	25
Removing and replacing the 40-character LCD	26
Removing and replacing the character/graphics display	27
Service procedures for CRTs.	28
Removing and replacing the post-mounted CRT.	28
Removing and replacing the wedge-mounted CRT.	29

Removing and replacing the table-mounted CRT	30
Removing and replacing the CRT mounting plate	30
Removing and replacing the CRT post mount attached to the counter.	31
Removing and replacing the table mount attached to the post	32
Chapter 4. Point-of-sale keyboards.	35
Keyboard types.	36
Attaching the cables to the system unit	37
Securing IBM USB POS keyboard cables	37
Securing the cable using cable ties	38
Keyboard messages	38
Keyboard/pointer symptoms	38
Using the joystick on the PS/2 ANPOS keyboard with integrated pointing device	40
Device driver considerations	40
Ergonomic considerations	41
Removing and replacing CANPOS keyboard components	42
Removing and replacing the CANPOS keypad assembly	43
Removing and replacing the CANPOS keyboard logic card	45
Removing and replacing the CANPOS keyboard with MSR	46
Removing and replacing retail POS keyboard components	48
Removing and replacing the keypad assembly	50
Removing and replacing the MSR	50
Removing and replacing the MSR flexible cable	51
Removing and replacing the LCD	52
Removing and replacing the keyboard logic card	52
Removing and replacing the lock insert	53
Removing and replacing the blank lock insert.	53
Removing and replacing USB keyboard-V components	54
Opening the cover	54
Removing and replacing the logic board	54
Removing and replacing the magnetic stripe reader	56
Removing and replacing the speaker assembly	57
Removing and replacing the keyboard matrix unit	58
Removing and replacing the top cover assembly	59
Removing and replacing USB PLU keyboard/display components	59
Opening the cover	59
Removing and replacing the VFD assembly	60
Removing and replacing the keyboard matrix unit	61
Removing and replacing the logic board	62
Removing and replacing the bottom cover assembly	64
Removing and replacing the top cover assembly	64
USB PLU extension box	65
Chapter 5. Parts catalog	67
How to use this parts catalog	67
Assembly 1: Cash drawer, wide	70
Assembly 2: Cash drawer (4693/4694, 4683/4684).	72
Assembly 3: Cash drawer, compact	74
Assembly 4: Video displays	76
Assembly 5: 40-character displays.	78
Assembly 6: USB and RS-485 character/graphics display	80
Assembly 7: PS/2 ANPOS keyboard with integrated pointing device	82
Assembly 8: CANPOS keyboard with integrated pointing device	86
Assembly 9: Keyboard, USB and RS-485, 50-key, with or without MSR	90
Assembly 10: Keyboard, USB and RS-485, 50-key, with MSR and LCD	92
Assembly 11: Keyboard, USB, 50-key, with JUCC (Japan)	94

Assembly 12: Keyboard, USB and Modifiable Layout RS-485, 133-key, with MSR	96
Assembly 13: Keyboard, USB and RS-485, ANPOS, with MSR	98
Assembly 14: Keyboard, USB and RS-485, ANKPOS, with MSR (Japan)	102
Assembly 15: Keyboard-V, USB (Japan)	104
Assembly 16: USB PLU keyboard/display (Japan, Korea)	106
Assembly 17: USB PLU extension box (Japan, Korea)	108
Assembly 18: Fillers for character/graphics display and printer (SurePOS 700 Japan and Korea)	110
Assembly 19: Fillers and table-top slanted I/O tray (SurePOS 700)	112
Assembly 20: Countertop non-keyboard integration tray and filler panels (SurePOS 500)	114
Assembly 21: Cash drawer non-keyboard integration tray and filler panels (SurePOS 500)	116
Assembly 22: Countertop and cash drawer keyboard integration tray and filler panels (SurePOS 500)	118
Assembly 23: Other FRUs that are not shown	120
Appendix A. Understanding USB	123
USB advantages	123
USB device identification and enumeration process	123
Voltage for USB connectors.	124
Appendix B. Notices	125
Electronic emission notices	127
Federal Communications Commission (FCC) statement	127
Industry Canada Class A Emission Compliance statement	127
Avis de conformité aux normes d'Industrie Canada	127
European Union (EU) Mark of Conformity statement.	127
Germany	128
Australia and New Zealand	128
Chinese Class A warning statement.	129
Japanese power line harmonics compliance statement.	129
Japanese Voluntary Control Council for Interference (VCCI) statement	129
Korean communications statement	129
Taiwanese Class A warning statement	130
Taiwan contact information	130
Taiwanese battery recycling statement.	130
Cable ferrite requirement.	130
Electrostatic Discharge (ESD)	130
End of life disposal	131
Trademarks.	132
Appendix C. Safety information	133
Glossary	139
Index	147
Part number index.	151

Figures

1. Setting the cash drawer using the jumper override	4
2. Removing and replacing a full-size cash drawer	7
3. Cash drawer slide assembly	8
4. Mounting locations of the filler panels	9
5. Installed filler panels for displays and keyboards	9
6. Installing the display filler panel	10
7. Installing the keyboard filler panel	10
8. Installing the keyboard replacement filler panel	11
9. C/G Display and Printer Fillers	12
10. Releasing the drawer from the slide assembly	13
11. Removing and replacing the compact cash drawer	13
12. Removing and replacing the slide latches	14
13. Compact cash drawer slide assembly	15
14. Compact cash drawer rollers	16
15. Removing the coin roll cutter	17
16. Removing the security clip (compact cash drawer)	17
17. Removing and replacing the top cover	18
18. Cash drawer latch and sensor assembly	19
19. Lock assembly	20
20. Lock inserts and accessories	21
21. Aligner positions	21
22. Removing and replacing the display	25
23. Removing the frame	25
24. Removing the lens	26
25. Disassembling the display	26
26. Disconnecting the display cable from the post	27
27. Sliding the display out of the holder	27
28. Assembling and disassembling the post	27
29. Removing and replacing the character/graphics display	28
30. Post-mounted CRT	29
31. Location of the power cord and video cable for a wedge-mounted monochrome CRT	30
32. Mounting plate for CRT that is mounted on short post	31
33. Attaching CRT to the counter	32
34. Table mount attached to post mount	33
35. Keyboard types for IBM Store Systems	36
36. Pictorial steps to attach the cable with clips and brackets	37
37. Securing the cable with cable ties	38
38. PS/2 ANPOS keyboard with integrated pointing device	40
39. Resting finger positions	41
40. Thumb position	42
41. CANPOS Keyboard	42
42. Removing the keyboard from the integration tray	44
43. CANPOS keypad assembly without MSR	45
44. CANPOS keypad assembly with MSR	47
45. Removing the MSR control card	48
46. Removing keyboard components	49
47. Removing the keypad assembly	50
48. Example of MSR flexible cable assembly	51
49. Removing the flexible cable from the connector holder	51
50. Inserting the flexible cable	52
51. Locked connector position	52
52. Lock accessories	53
53. USB keyboard-V components – part 1	54

54. USB keyboard-V components – part 2	55
55. USB keyboard-V components – part 3	56
56. USB keyboard-V components – part 4	57
57. USB keyboard-V components – part 5	58
58. USB keyboard-V components – part 6	59
59. Removing the cover of the USB PLU keyboard/display	60
60. Removing the screws	61
61. Removing the screws	62
62. Disconnecting the connector, screws, and cables	63
63. Removing the screws	63
64. Disconnecting the connector to the LED assembly	64

Tables

1.	Where to find repair information	1
2.	Cash drawer jumper settings	4
3.	Cash drawer problems	5
4.	Repair actions for display problems	24
5.	Repair actions for keyboard/pointer problems	39
6.	Symptom explanation and cause	65
7.	Problem isolation steps	65
8.	USB power and voltage – VFD display connectors	124
9.	USB power and voltage – LCD display and keyboard connectors	124

last update: March 22, 2007

About this guide

This guide describes the problem-determination and repair procedures for cash drawers, displays, keyboards, and options that are attached to IBM® SurePOS™ systems, which are commonly referred to as Store Systems.

To begin, go to Chapter 1, “Diagnostics, tests, and procedures,” on page 1 and select the starting point that best describes the action you want to perform.

Who should use this guide

Service personnel using this guide should be trained to service:

- IBM point-of-sale (POS) terminals
- USB input/output (I/O) devices attached to point-of-sale terminals
- IBM personal computers and personal systems

How this guide is organized

This guide is organized as follows:

Chapter 1, “Diagnostics, tests, and procedures” provides general information about the diagnostics, tests, and procedures that are used to test and repair input/output (I/O) devices that are attached to Store Systems.

Chapter 2, “Point-of-sale cash drawers” provides information about the messages, symptoms, and procedures that are used to test and repair cash drawers that are attached to Store Systems.

Chapter 3, “Point-of-sale displays” provides information about symptoms as well as procedures that are used to test and repair displays that are attached to Store Systems.

Chapter 4, “Point-of-sale keyboards” provides information about the messages, symptoms, and procedures that are used to test and repair keyboards that are attached to Store Systems.

Appendix A, “Understanding USB” contains information about the universal serial bus (USB).

Appendix B, “Notices” contains trademarks that are referenced in the guide and other miscellaneous notices.

Appendix C, “Safety information” contains translations of the safety notices.

Related publications

This document and the following related IBM publications are available in PDF format from the IBM Retail Store Solutions Web site at <http://www.ibm.com/solutions/retail/store/support/> (select **Support**, then select **Publications**).

- *SurePOS 720, 740, and 780 Planning, Installation and Operation Guide*, GA27-4328
- *SurePOS 720, 740, and 780 Hardware Service Guide*, SA27-4329
- *Safety Information – Read This First*, GA27-4004
- *SurePOS 700 Series: Installation and Operation Guide*, GA27-4293
- *SurePOS 700 Series: Hardware Service Guide*, GY27-0363
- *SurePOS 700 Series: System Reference*, SA27-4224
- *SureMark Printers: User’s Guide*, GA27-4151

- *SureMark Printers: Hardware Service Manual, GA27-0355*
- *4820 SurePoint Solution: Installation and Service Guide, GA27-4231*
- *4820 SurePoint Solution: System Reference, SA27-4249*
- *Point of Sale Subsystem: Programming Reference and User's Guide, SC30-3560*
- *Point of Sale Subsystem: Installation, Keyboards and Code Pages, GC30-3623*
- *Store Systems POS I/O Devices Installation and Operation Guide, GA27-4028*
- *IBM Store Systems Parts Catalog, SI31-0097*

last update: March 22, 2007

Summary of Changes

March 2007: Updated notices.

January 2007: The parts listing for the USB and RS-485 character/graphics display and the CANPOS keyboard are updated.

Providing feedback

Your feedback is important in helping IBM provide accurate and high-quality information.

You can use either of these ways to provide feedback:

- Go to <http://www.ibm.com/solutions/retail/store>. Click **Support**, then click **Publications**. Click the **publication comments** within the introductory text. Provide the requested information and your comments. Be sure to include the name and form number of the document in the [Publication ID] field.
- Print and complete the form at the end of this document. Return the form to IBM by mail or by giving it to an IBM representative.

If applicable, include a reference to the specific location of the text (for example, the page or table number) on which you are commenting.

Between major revisions of this document, there might be minor technical updates. The latest version of this document is available on the Retail Store Solutions Web site at www.ibm.com/solutions/retail/store/support/publications/.

Chapter 1. Diagnostics, tests, and procedures

This guide provides test and repair information for input/output (I/O) devices—including keyboards, displays, and cash drawers—that are attached to a Store System. The SurePOS models support both the RS-485 POS I/O (4694 family), as well as the powered USB I/O (IBM SurePOS 700 family). A unique tailgate design allows for different configurations of I/O that you can later upgrade or change in the field. The initial configuration offerings are the USB/RS-485 (EIA-485) configuration and the USB-only configuration.

Note: This guide provides test information for the 4610 SureMark™ printers and for the SurePoint™ Solution display. For repair information on those devices, refer to the *SureMark Printers: Hardware Service Manual* or the *4820 SurePoint Solution: Installation and Service Guide*.

For information about RS-485 I/O devices, refer to the *Store Systems POST I/O Devices Installation and Operation Guide*.

To determine if a Store System unit or one of the I/O devices is failing, use the POS Device Diagnostics program. You can also use the *problem determination guide* for the operating system or your Hardware Service Guide.

Determining the problem

This section describes the procedures to follow to determine whether the problem is caused by the port on the Store System or by the I/O device.

Follow these steps for efficient problem resolution:

1. Unplug the failing device from the port on the Store System.
2. Plug a similar device and cable that you know are working into the port to which the failing device was attached.
3. If the new device fails, then the port is the problem. If the new device functions properly on the port, then continue with problem diagnosis for the original failing device.

See Appendix A, “Understanding USB,” on page 123 for more information about the ports on the Store System.

When you have determined that a repairable device is failing, not the port, refer to Table 1 to find information about how to repair the device.

Table 1. Where to find repair information

Run a test	See “Standalone tests” on page 2.
Repair a cash drawer	See Chapter 2, “Point-of-sale cash drawers,” on page 3.
Repair a display	See Chapter 3, “Point-of-sale displays,” on page 23.
Repair a keyboard	See Chapter 4, “Point-of-sale keyboards,” on page 35.
Repair a 4820 SurePoint Solution display	Refer to the <i>4820 SurePoint Solution: Installation and Service Guide</i> .

Table 1. Where to find repair information (continued)

Repair a 4610 SureMark printer	Refer to the <i>SureMark Printers: Hardware Service Manual</i> .
--------------------------------	--

For devices that are not designed to be repaired, simply replace the entire unit when required. A repair identification (RID) tag must be placed on any unit that has a machine type and serial number.

Standalone tests

SurePOS 720, 740, and 780 standalone tests are available from the web site, <http://www.ibm.com/solutions/retail/store/support/>.

For a description of the standalone tests for the 4610 SureMark printer, refer to the *SureMark Printers: User's Guide*.

For a description of the standalone tests for the 4820 SurePoint Solution display, refer to the *IBM 4820 SurePoint Solution: System Reference*.

Chapter 2. Point-of-sale cash drawers

Connecting non-IBM cash drawers	4
Cash drawer messages	4
Cash drawer symptoms	5
Service procedures for full-size cash drawers	6
Removing and replacing the cash drawer (full-size)	6
Removing and replacing the slide assembly (full-size)	7
Removing and replacing the slanted cash drawer I/O tray (full-size)	8
Installing filler panels (full-size)	8
Fillers for character/graphics display and printer (Japan only)	11
Service procedures for compact cash drawers	12
Removing and replacing the cash drawer (compact)	12
Removing and replacing the slide latches (compact)	13
Removing and replacing the slide assembly (compact)	14
Removing and replacing the rollers (compact)	15
Removing and replacing the coin-roll cutter (compact)	16
Removing and replacing the security clip (compact)	17
Service procedures for cash drawers (all sizes)	17
Removing and replacing the top cover (all sizes)	18
Removing and replacing the latch and sensor assembly (all sizes)	18
Removing and replacing components of the latch and sensor assembly (all sizes)	19
Removing and replacing the lock assembly (all sizes)	20
Removing and replacing the lock insert	21
Removing and replacing the blank lock insert.	22

This chapter contains repair information for servicing point-of-sale cash drawers that are used with Store Systems.

The types of cash drawers are full-size (for the wide footprint models) and compact (for the narrow footprint models).

Note: It is assumed that you were directed to this chapter from the software *problem determination guide* or from your Hardware Service Guide; and it is assumed that you have isolated the failure to the cash drawer or cable.

DANGER

To avoid a shock hazard:

- **Do not connect or disconnect any cables or perform installation, maintenance, or reconfiguration of this product during an electrical storm.**
- **The power cord must be connected to a properly wired and earthed receptacle.**
- **Any equipment to which this product will be attached must also be connected to properly wired receptacles.**

DANGER

When possible, use one hand to connect or disconnect signal cables, to prevent a possible shock from touching two surfaces with different electrical potentials.

Connecting non-IBM cash drawers

If you are using a non-IBM cash drawer, the automatic mode will not work correctly, and damage to either the cash drawer, system unit, or both is possible. You must configure the cash drawer voltage (24 V or 38 V) by using the configuration options in the POS configuration setup program or with the jumper override. Figure 1 shows the location of the cash drawer voltage jumper on the riser card and a diagram with the position of the jumpers.

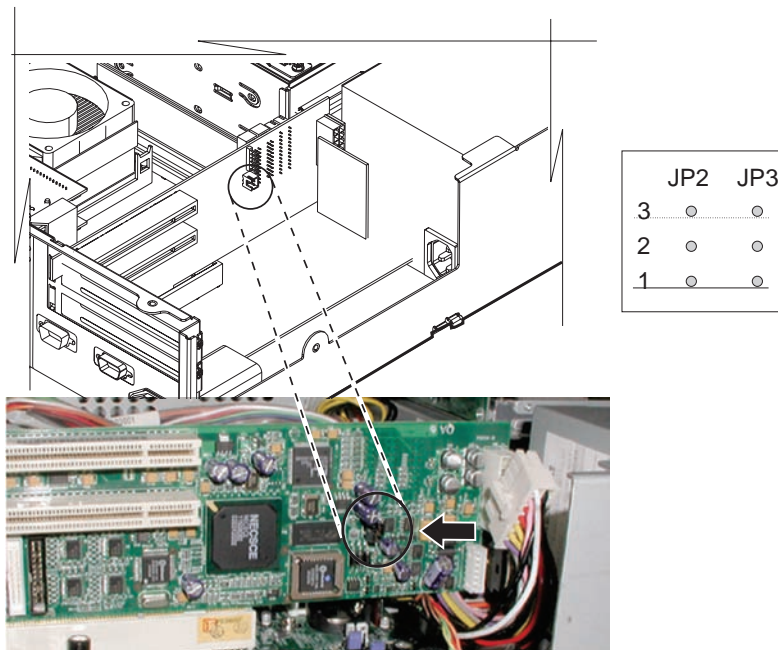

Figure 1. Setting the cash drawer using the jumper override

Table 2 provides the correct jumper settings for the 24 V and 38 V cash drawers:

Table 2. Cash drawer jumper settings

Voltage	Jumper JP2	Jumper JP3
Automatic setup (default)	Not used	2-3
Manual 24 V	2-3	1-2
Manual 38 V	1-2	1-2

Cash drawer messages

No messages are issued about cash drawers. To determine the cause of a cash drawer problem, see “Cash drawer symptoms” on page 5.

Cash drawer symptoms

Table 3. Cash drawer problems

Symptom	Repair action
<p>The cash drawer does not open or close smoothly, or it appears to be binding.</p>	<ol style="list-style-type: none"> 1. Look for items that could cause binding, such as pens or paper clips trapped between the drawer and cover or the drawer and base. 2. Compact drawer only: Remove the drawer and the rollers at the rear of the drawer and at the front of the base. Replace the rollers if necessary. See “Removing and replacing the rollers (compact)” on page 15. 3. Check to see if the slide assembly in the base is binding. Replace the slide assembly if necessary. See “Removing and replacing the slide assembly (full-size)” on page 7 or “Removing and replacing the slide assembly (compact)” on page 14.
<p>The cash drawer does not open when the cash drawer key is turned to the open position.</p>	<ol style="list-style-type: none"> 1. Replace the lock insert if the lock does not turn with the key. 2. Gently pull the drawer open while holding the key turned to the open position to determine if the slide assembly is binding. Look for items that may cause binds, such as pens or paper clips. Replace the slide assembly if necessary. See “Removing and replacing the slide assembly (full-size)” on page 7 or “Removing and replacing the slide assembly (compact)” on page 14. 3. Replace the cam, pawl, and spring kit. See “Removing and replacing components of the latch and sensor assembly (all sizes)” on page 19. 4. Check for a bent actuator rod. Replace the actuator rod if necessary.
<p>The cash drawer does not open when doing store transactions or running cash drawer tests, but it opens when the cash drawer key is turned to the open position.</p>	<ol style="list-style-type: none"> 1. Replace the latch and sensor assembly card. See “Removing and replacing the latch and sensor assembly (all sizes)” on page 18. 2. Replace the cable. 3. Replace the planar board. Refer to your Hardware Service Guide.

Table 3. Cash drawer problems (continued)

Symptom	Repair action
The cash drawer does not stay closed.	<ol style="list-style-type: none"> 1. Make sure the lock is not stuck in the open position. Replace the lock if necessary. See “Removing and replacing the lock assembly (all sizes)” on page 20. 2. Replace the cam, pawl, and spring kit. See “Removing and replacing components of the latch and sensor assembly (all sizes)” on page 19. 3. Replace the latch and sensor assembly card. See “Removing and replacing the latch and sensor assembly (all sizes)” on page 18. 4. Replace the drawer. See “Removing and replacing the cash drawer (full-size)” or “Removing and replacing the cash drawer (compact)” on page 12. 5. Replace the planar board. Refer to your Hardware Service Guide.
The status displayed by the cash drawer tests does not match the physical status of the cash drawer being tested. For example, the test says CD A IS CLOSED when cash drawer A is actually open.	<ol style="list-style-type: none"> 1. Replace the latch and sensor assembly card. See “Removing and replacing the latch and sensor assembly (all sizes)” on page 18. 2. Replace the cam, pawl, and spring kit. See “Removing and replacing components of the latch and sensor assembly (all sizes)” on page 19. 3. Replace the planar board. Refer to your Hardware Service Guide.

Service procedures for full-size cash drawers

Use these procedures to service full-size cash drawers, which are about 435 mm (17 in.) wide. These cash drawers can be integrated with Store Systems that have a wide footprint. They can also be used in a distributed configuration with any Store System.

Removing and replacing the cash drawer (full-size)

To remove the cash drawer:

1. If the cash drawer is mounted to the underside of a counter, refer to the instructions that came with the mounting brackets.
2. Switch OFF the power to the Store System. Unplug the system power cord from the external power source.
3. Remove the Store System base cover as described in your Hardware Service Guide, and unplug the power cord from the system unit at the power supply.
4. Open the cash-drawer rear cover.
5. Unplug the cable from the rear of the cash drawer.
6. Remove the integration tray (refer to your Hardware Service Guide).
7. Open the cash drawer, and pull it all of the way out.
8. Remove the till.

9. Push in on the buttons in the rails (see Figure 2), and pull up on the front of the drawer until the drawer is free from the slides. Pull the drawer forward out of the base.

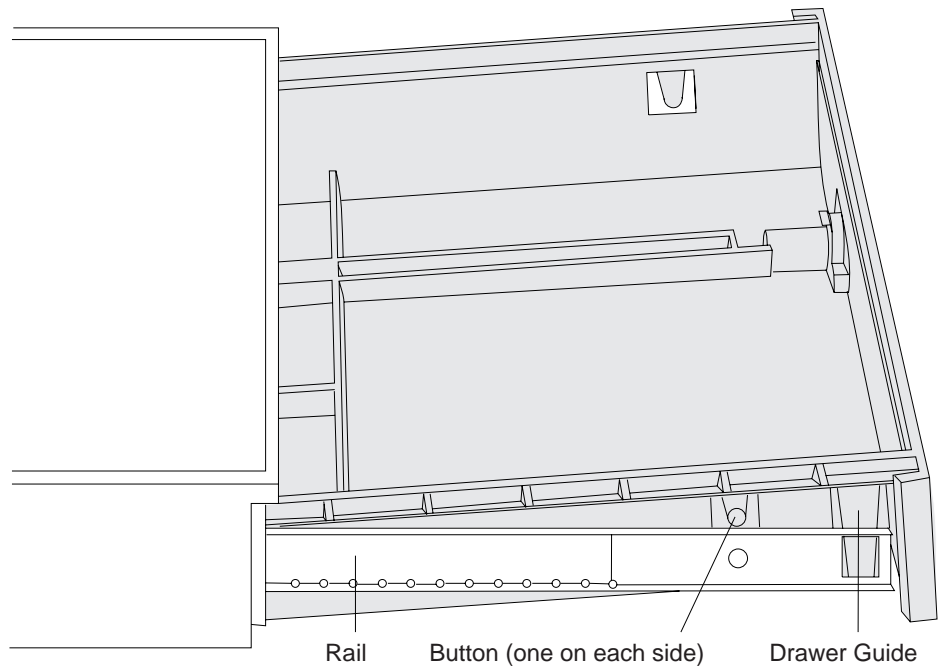

Figure 2. Removing and replacing a full-size cash drawer

To replace the cash drawer:

1. Make sure the latch assembly is unlatched; otherwise the drawer will not close properly.
2. Pull both slides all of the way out.
3. Position the rear of the drawer into the slides so that the drawer guide on each side of the drawer aligns with the corresponding opening on each side (see Figure 2).
4. Pivot the front of the drawer downward until it is positioned fully into the slides.
5. Close the drawer to make sure it closes correctly and stays closed.

Removing and replacing the slide assembly (full-size)

To remove the cash drawer slide assembly:

1. Disconnect the cash drawer cable.
2. Remove the drawer (see “Removing and replacing the cash drawer (full-size)” on page 6).
3. Remove the latch assembly (see “Removing and replacing the latch and sensor assembly (all sizes)” on page 18).
4. Remove the three screws that secure the slide to the base, and lift the slide assembly out (see Figure 3 on page 8).

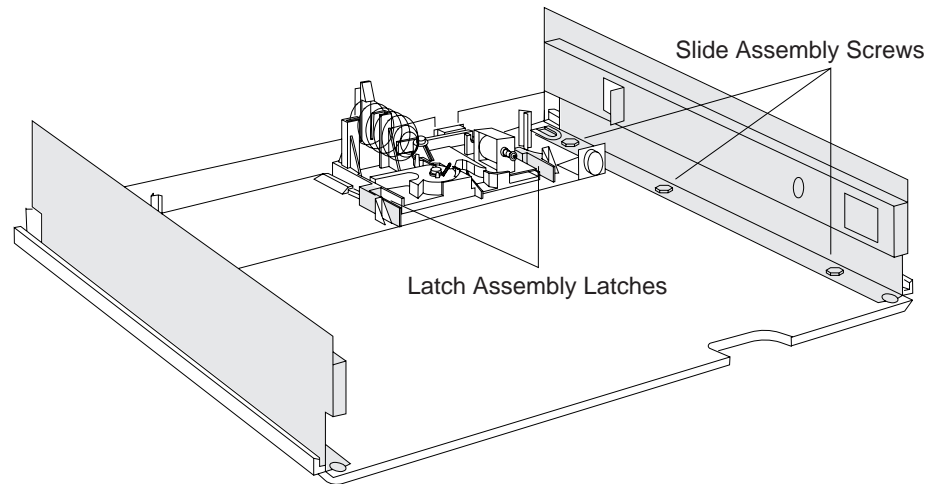

Figure 3. Cash drawer slide assembly

5. If necessary, remove the top cover from the base (see “Removing and replacing the top cover (all sizes)” on page 18).

To replace the cash drawer slide assembly:

1. Place the slide assembly into the base so that the screw holes are aligned.
2. Insert the screws that secure the slides into the base.
3. Reinstall the latch assembly.
4. Reinstall the top cover, if it was removed.
5. Reinstall the drawer.

Removing and replacing the slanted cash drawer I/O tray (full-size)

To remove an I/O tray:

1. Disconnect the system unit power cord.
2. Disconnect the power cords for all I/O devices that are contained in the I/O tray.
3. Remove any installed filler panels.
4. Remove any I/O devices that are contained in the I/O tray.
5. Remove the two screws that secure the rear of the I/O tray to the cash drawer.
6. Lift the I/O tray off of the cash drawer.
7. If you are going to replace the I/O tray, then push each of the front mounting tabs forward until it unlatches. Lift each mounting tab up, and lift the I/O tray out to remove it.

To replace an I/O tray, reverse this procedure.

Installing filler panels (full-size)

For each type of filler panel, Figure 4 on page 9 illustrates the two locations where you can install the filler panel. One side of each filler panel must overlap a tab on the side of the I/O tray.

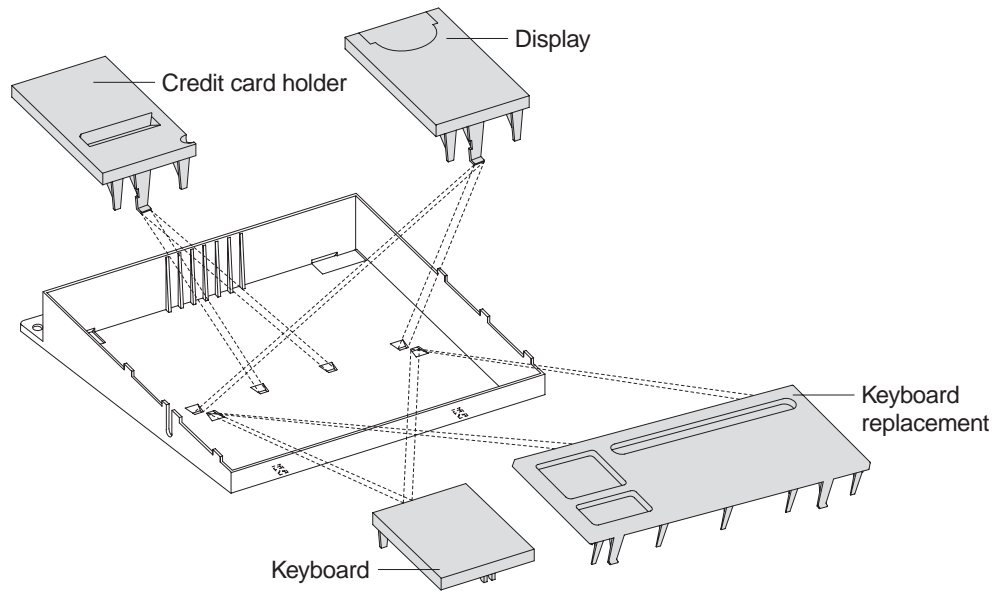

Figure 4. Mounting locations of the filler panels

Note: The dashed lines indicate alternative locations for mounting each filler panel.

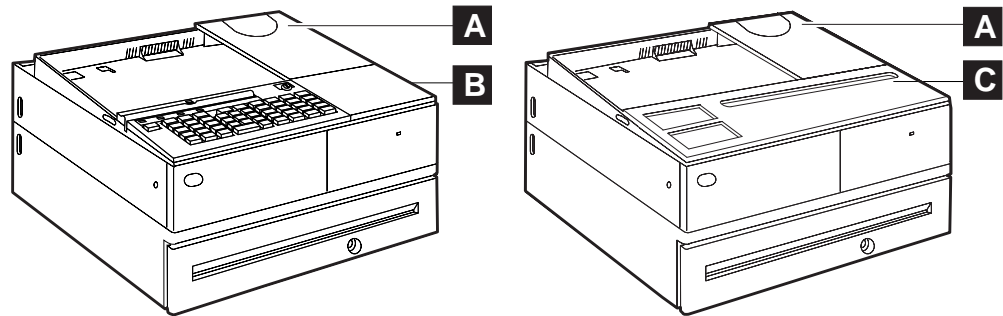

Figure 5. Installed filler panels for displays and keyboards

Figure 6 on page 10 through Figure 8 on page 11 shows how to install the keyboard and display filler panels. (The credit card holder filler panel is installed in a similar manner.)

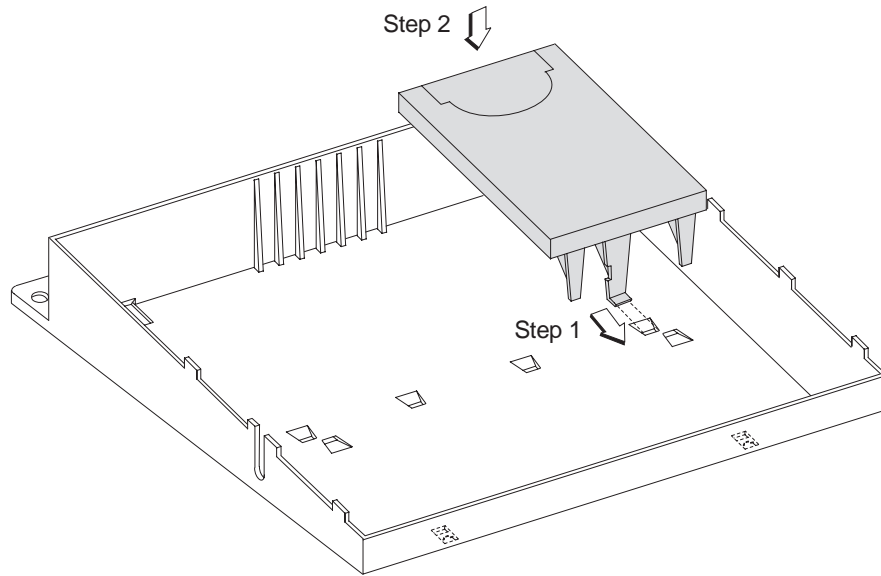

Figure 6. Installing the display filler panel

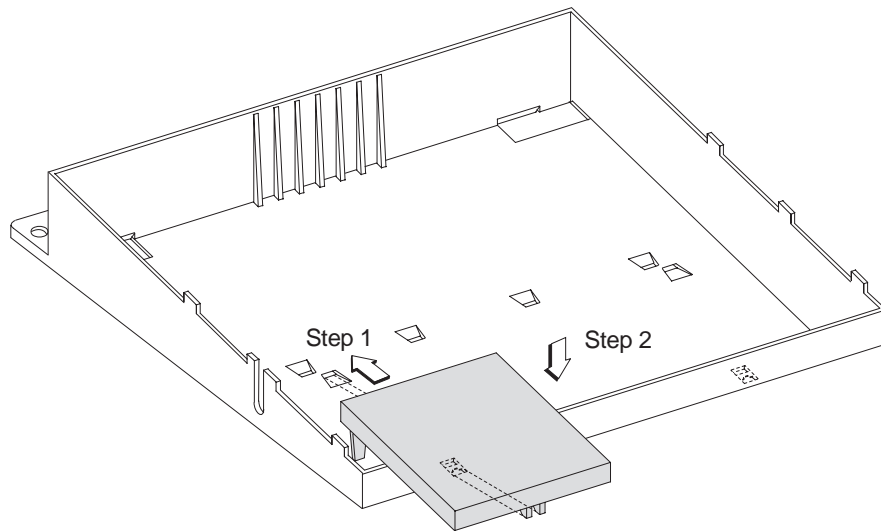

Figure 7. Installing the keyboard filler panel

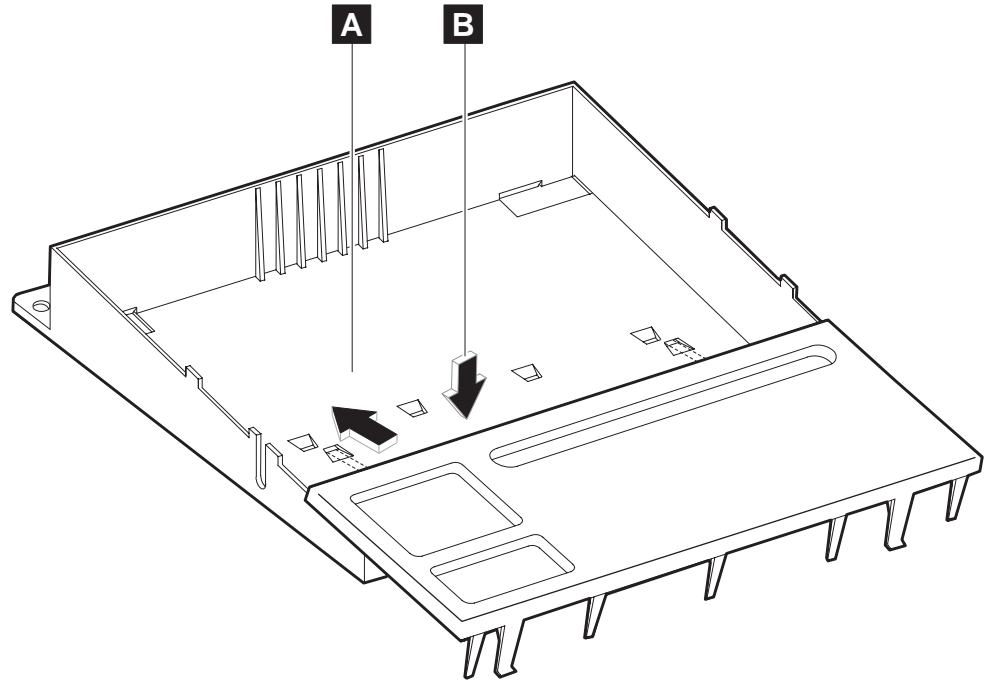

Figure 8. Installing the keyboard replacement filler panel

To install the filler panels:

1. Position the display filler panel (**A** in Figure 5 on page 9) on the system unit. **Do not remove** the knockout section.
2. If you have a short keyboard, place the keyboard filler panel (**B** in Figure 5 on page 9) beside the keyboard. Hook the foot of the keyboard filler panel into the hole, and snap the front of the filler panel into place.
3. If you are using a touch screen and therefore are not using a keyboard, place the keyboard replacement filler panel (**C** in Figure 5 on page 9) beside the keyboard. Hook the foot of the keyboard replacement filler panel into the hole, and snap the front of the filler panel into place.

Fillers for character/graphics display and printer (Japan only)

Figure 9 on page 12 shows the location of the fillers and how to install them. Insert the tab in the slot and push the filler toward the tab until it snaps into place.

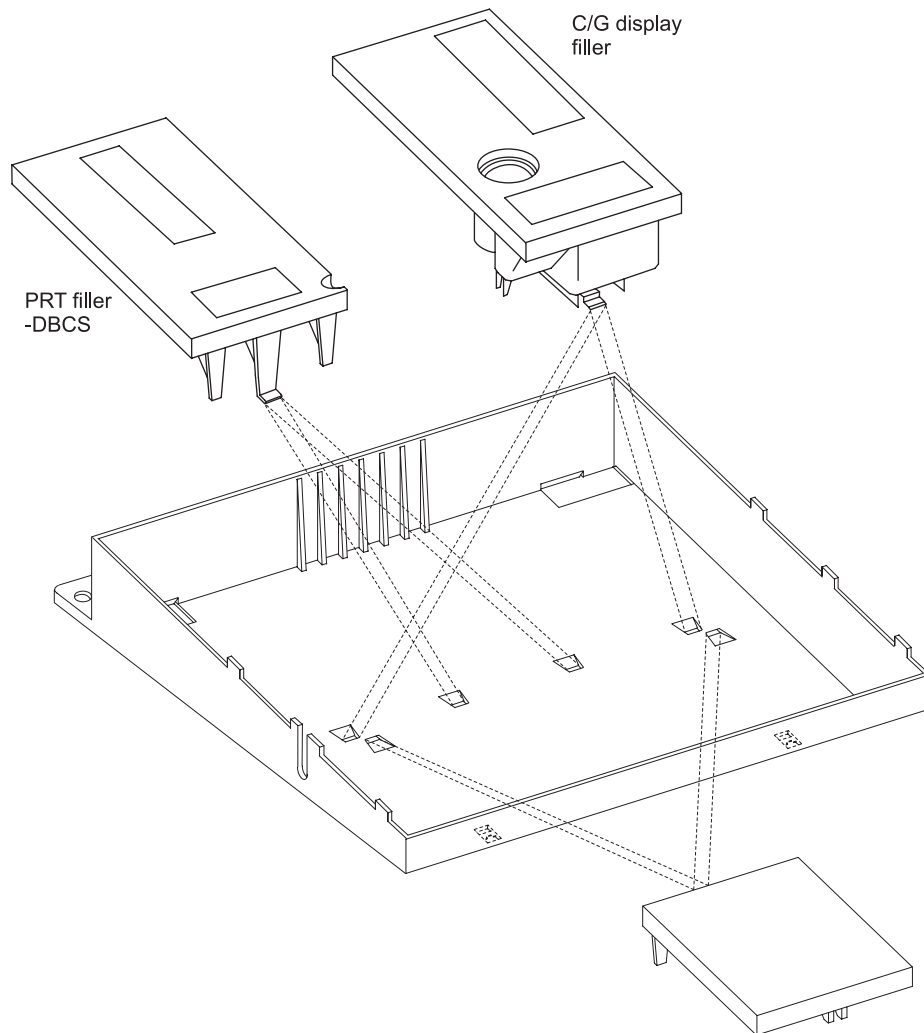

Figure 9. C/G Display and Printer Fillers

Service procedures for compact cash drawers

Use these procedures to service compact cash drawers, which are about 318 mm (12.5 in.) wide. These cash drawers can be integrated with Store Systems that have a narrow footprint. They can also be used in a distributed configuration with any Store System.

Removing and replacing the cash drawer (compact)

To remove the compact cash drawer:

1. Disconnect the cash drawer cable.
2. Open the cash drawer, and pull it all of the way out.
3. Remove the till.
4. Using a coin or large screwdriver, move the drawer slide latches to the right (facing the front of the drawer; see Figure 10 on page 13 and Figure 11 on page 13) until the drawer is released from the slide assembly. Lift the drawer out.

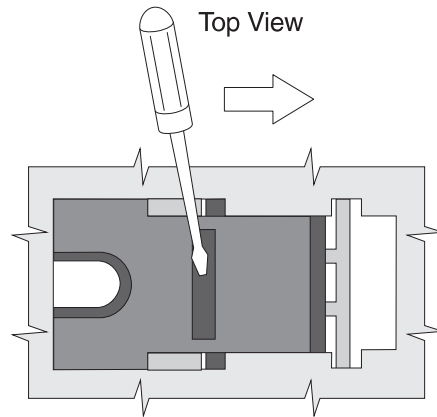

Figure 10. Releasing the drawer from the slide assembly

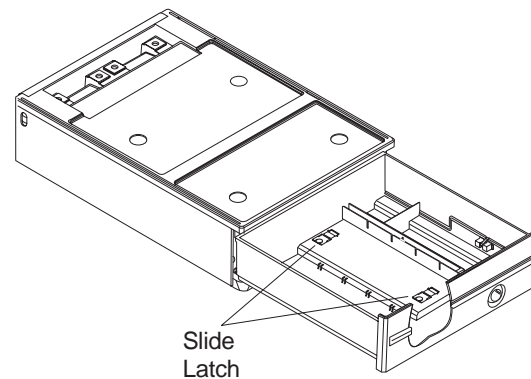

Figure 11. Removing and replacing the compact cash drawer

5. If you will be replacing the drawer, remove the lock assembly, and install it in the new drawer (see “Removing and replacing the lock assembly (all sizes)” on page 20).

To replace the compact cash drawer, reverse this procedure.

Removing and replacing the slide latches (compact)

To remove the cash drawer slide latches:

1. Disconnect the cash drawer cable.
2. Remove the drawer (see “Removing and replacing the cash drawer (compact)” on page 12).
3. Remove the slide latch by sliding it all of the way to the left (latched position).
4. Gently pry and press at the point shown in Figure 12 on page 14.

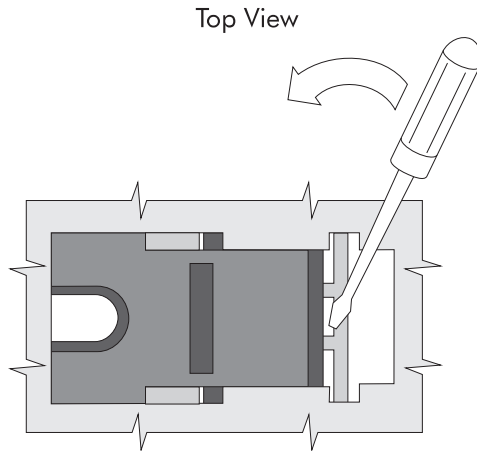

Figure 12. Removing and replacing the slide latches

To replace the latch, insert it through the opening in the bottom of the drawer, and rotate it into position. Then push up from the bottom until it latches.

Removing and replacing the slide assembly (compact)

To remove the slide assembly:

1. Disconnect the cash drawer cable.
2. Remove the cash drawer (see "Removing and replacing the cash drawer (compact)" on page 12).
3. Remove the three screws that secure the slide to the base, and lift the slide assembly out (see Figure 13 on page 15).

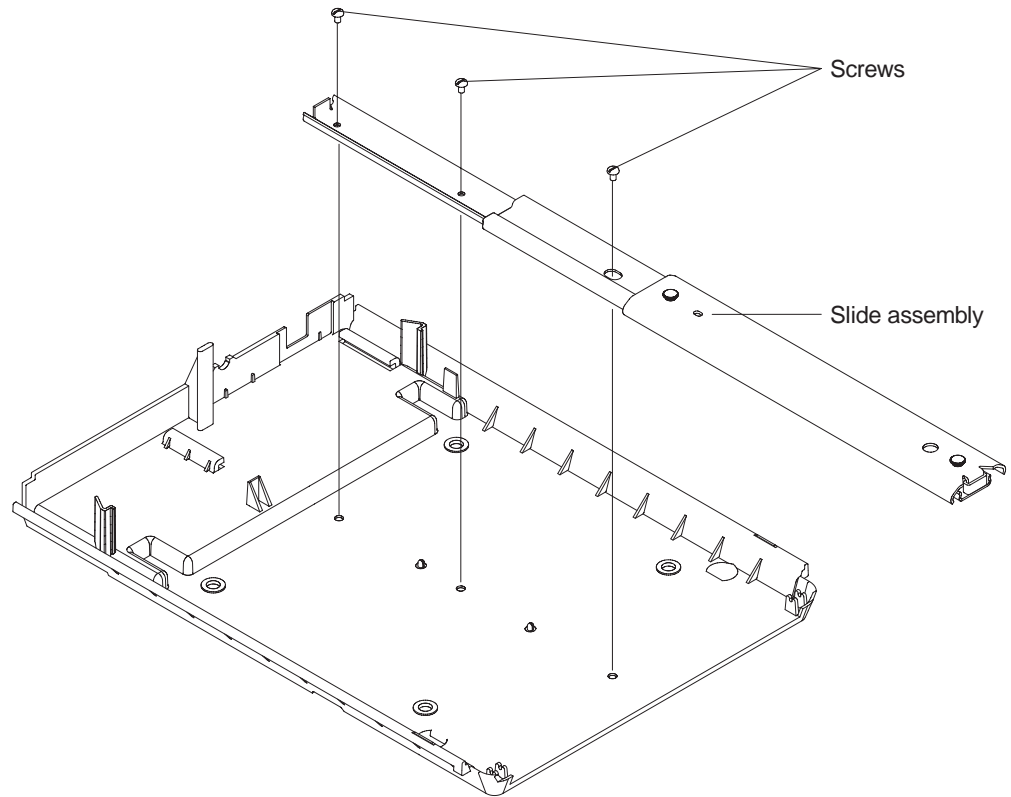

Figure 13. Compact cash drawer slide assembly

To replace the slide assembly:

1. Place the slide assembly into the base so that the screw holes are aligned.
2. Insert and tighten the screws that secure the slide to the base.

Removing and replacing the rollers (compact)

To remove and replace the cash drawer rollers:

1. Disconnect the cash drawer cable.
2. Remove the cash drawer (see "Removing and replacing the cash drawer (compact)" on page 12).

Note: There are four rollers: two ball-bearing rollers at the front of the base and two plastic rollers at the rear of the drawer assembly (see Figure 14 on page 16). They should all be replaced at the same time.

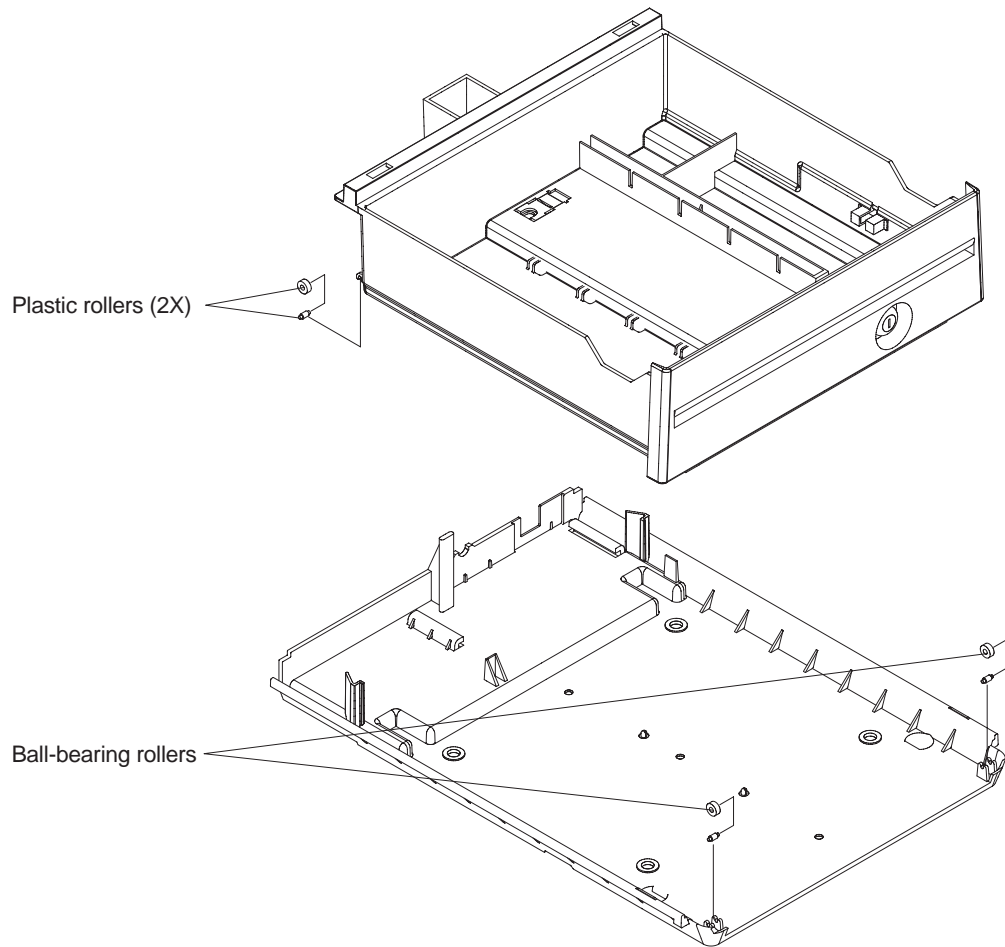

Figure 14. Compact cash drawer rollers

3. Each roller shaft is snapped into two plastic posts. To replace the roller and shaft, gently pry the roller and shaft out, and snap the new set into position. Be sure to use the ball-bearing rollers on the base and the plastic rollers on the drawer.

Removing and replacing the coin-roll cutter (compact)

To remove the coin roll cutter:

1. Open the cash drawer, and pull it all of the way out.
2. Remove the till.
3. From inside the drawer, squeeze the cutter latches together with your fingers and push the cutter outward until it can be removed from the outside (see Figure 15 on page 17).

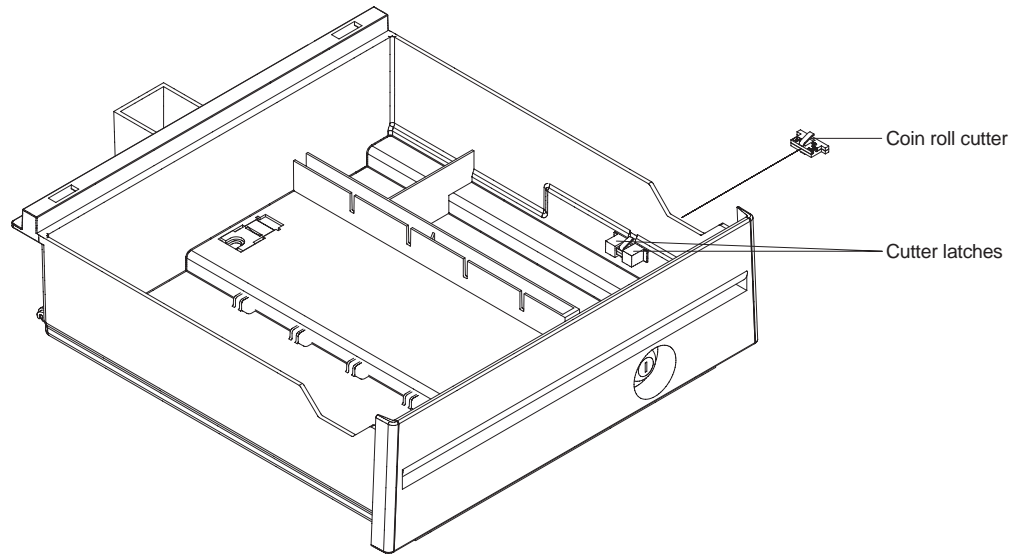

Figure 15. Removing the coin roll cutter

4. To replace the cutter, snap the new cutter into position from the outside.
5. Reassemble.

Removing and replacing the security clip (compact)

To remove the security clip:

1. Disconnect the cash drawer cable.
2. Open the rear cover of the cash drawer, and remove the cash drawer (see "Removing and replacing the cash drawer (compact)" on page 12).
3. Remove the top cover (see "Removing and replacing the top cover (all sizes)" on page 18).
4. Remove the security clip (see Figure 16).

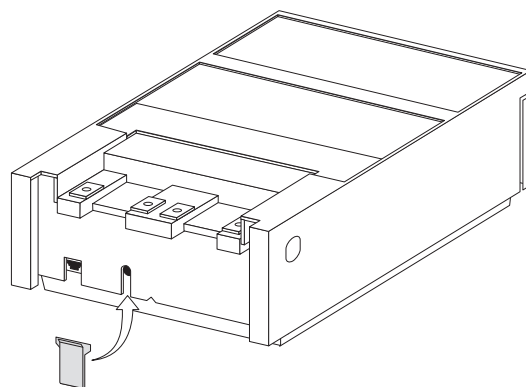

Figure 16. Removing the security clip (compact cash drawer)

To replace the security clip, reverse this procedure.

Service procedures for cash drawers (all sizes)

Use these procedures to remove and replace parts that are common to both compact and full-size cash drawers.

Removing and replacing the top cover (all sizes)

To remove the top cover of a cash drawer:

1. Disconnect the cash drawer cable from the rear of the cash drawer. (There may be other cables routed through the rear of the top cover.) Remove the rear panel by releasing it at the pivots. Separate the top cover and base without disturbing these cables. Only disconnect cables from the terminal unit when necessary.
2. Open the rear panel by pushing the buttons at the upper rear corners of the cover.
3. Set the devices mounted on the top cover to the side.
4. Remove the drawer (see “Removing and replacing the cash drawer (full-size)” on page 6 or “Removing and replacing the cash drawer (compact)” on page 12).
5. To separate the top cover from the base, reach in from the front and push the cover latches outward while pushing them to the rear. The cover slides off toward the rear (see Figure 17).

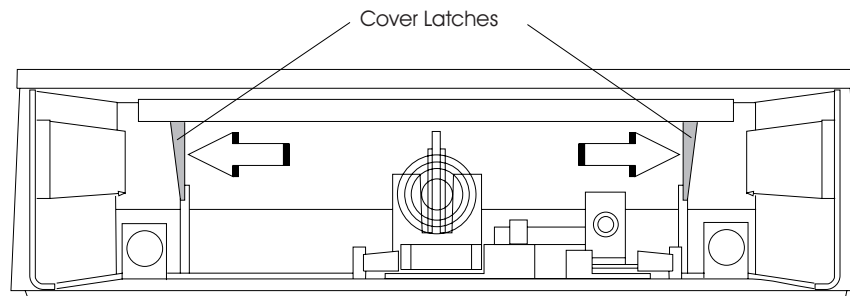

Figure 17. Removing and replacing the top cover

Removing and replacing the latch and sensor assembly (all sizes)

To remove the latch and sensor assembly:

1. Disconnect the cash drawer cable from the connector at the rear of the cash drawer.

Note: The assembly must be replaced with an assembly of the same voltage. See “Assembly 1: Cash drawer, wide” on page 70 and “Assembly 3: Cash drawer, compact” on page 74 for the assembly part numbers and voltages.
2. Remove the cash drawer (see “Removing and replacing the cash drawer (full-size)” on page 6 or “Removing and replacing the cash drawer (compact)” on page 12).
3. Reach in from the front and push the latch on each side of the latch assembly inward while pulling the assembly toward the front (see Figure 3 on page 8).

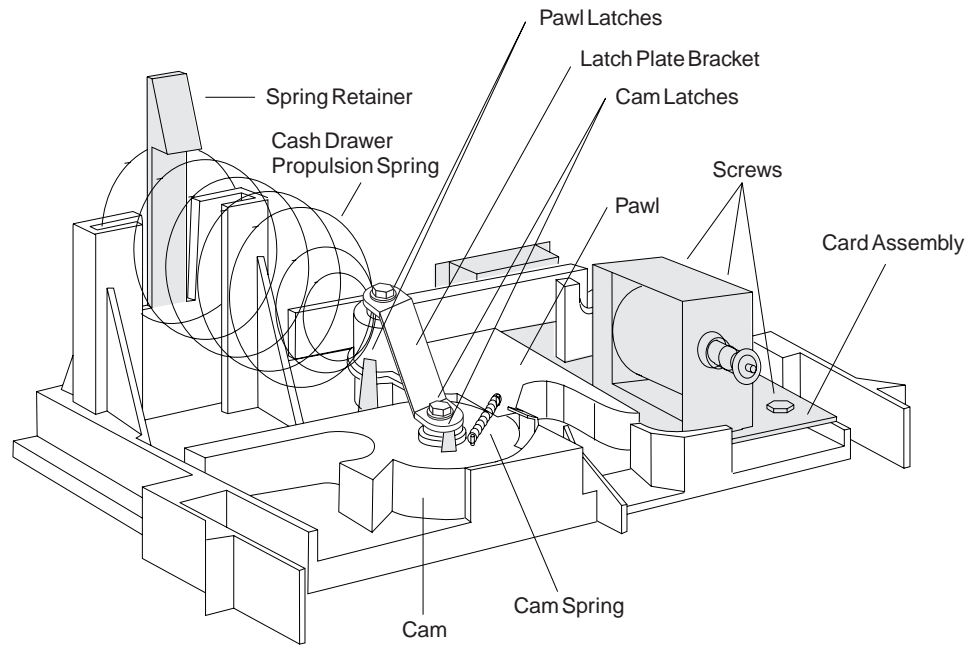

Figure 18. Cash drawer latch and sensor assembly

4. Slide the assembly out of the base.

To replace the latch and sensor assembly:

1. Slide the assembly into the base from the front, and align it with the slots in the base. Push the assembly to the rear until it locks into place.
2. Make sure that the latching mechanism is unlatched.
3. Reinstall the drawer.
4. Reconnect the cash drawer cable.

Removing and replacing components of the latch and sensor assembly (all sizes)

To remove the individual components of the latch and sensor assembly:

1. Disconnect the cash drawer cable.
2. Remove the cash drawer (see “Removing and replacing the cash drawer (full-size)” on page 6 or “Removing and replacing the cash drawer (compact)” on page 12).
3. Remove the latch assembly (see “Removing and replacing the latch and sensor assembly (all sizes)” on page 18).
4. Remove the cash drawer propulsion spring by pushing the spring retainer back then sliding the spring up and out of its mounting slots (see Figure 18).
5. Remove the latch plate bracket by removing the screw in the cam pivot post and the screw in the pawl pivot post (see Figure 18).
6. Remove the cam spring by lifting the ends of the small posts on the cam and the pawl (see Figure 18).
7. Spread apart the two pawl latches that hold the pawl on the pivot post, while lifting the pawl off of the post (see Figure 18).
8. Spread apart the two cam latches that hold the cam on the pivot post, while lifting the cam off of the post (see Figure 18).

9. Remove the three screws that retain the card assembly, and remove the card assembly (see Figure 18 on page 19).

To replace the individual components of the latch and sensor assembly, reverse this procedure.

Removing and replacing the lock assembly (all sizes)

To remove the lock assembly:

1. Remove the cash drawer (see “Removing and replacing the cash drawer (compact)” on page 12 or “Removing and replacing the cash drawer (full-size)” on page 6).
2. Remove the lock retainer clip holding the lock assembly on the inside of the drawer (see Figure 19).

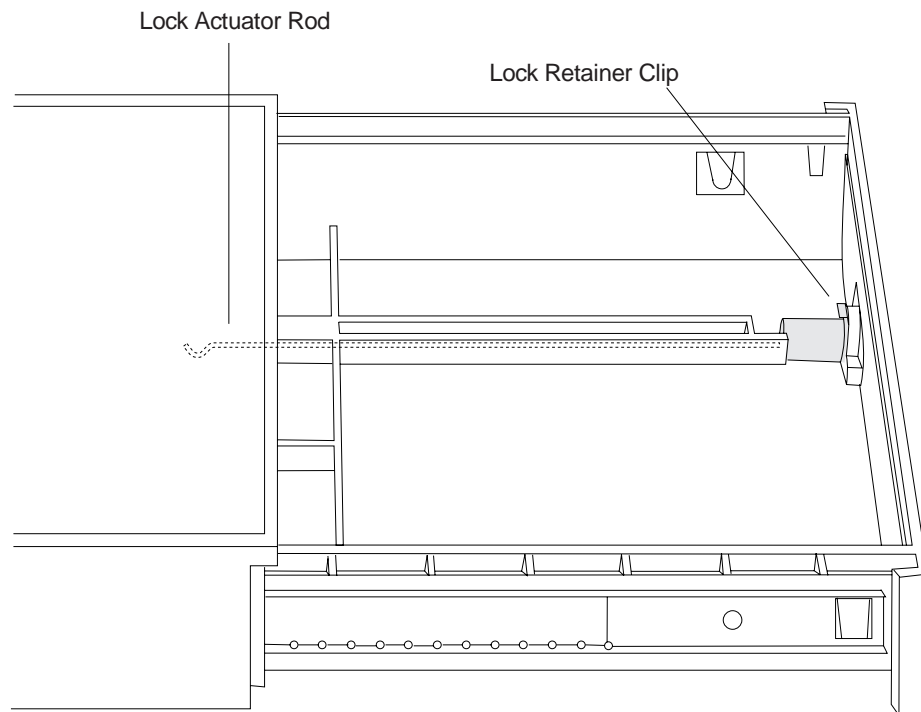

Figure 19. Lock assembly

3. Slide the lock assembly out of the front of the drawer.

Note: It might take some force to free the lock assembly.

To replace the lock assembly:

1. Make sure the lock actuator rod is in the position shown in Figure 19.
2. Slide the lock assembly all of the way into the opening in the front of the drawer, making sure that the end of the lock actuator rod is interlocked with the rear of the lock.
3. Reinstall the lock retainer clip.
4. Reinstall the drawer.

Removing and replacing the lock insert

This figure shows the blank lock and accessories:

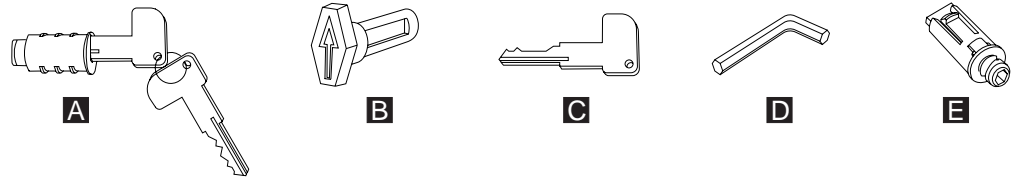

Figure 20. Lock inserts and accessories

To install a lock insert, you need the following items:

- Lock insert and keys **A**
- Aligner **B** (The aligner is a tool that is used to ensure that the slot at the bottom of the lock cylinder aligns with the lock insert being installed.)
- Brass installation-removal key **C**

To install a blank lock insert, you need the following items:

- Blank lock installation handle **D**
- Blank lock insert **E**

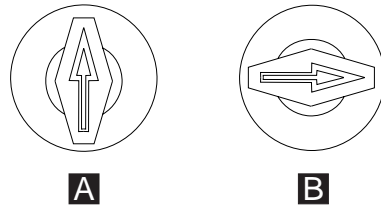

Figure 21. Aligner positions

That figure shows these positions:

- **A** – the aligner in place in the lock cylinder of the keyboard
- **B** – cash drawer
- **C** – service for system units

Note: When the aligner is in place, the arrow points in different directions, depending on the kind of device. Refer to this figure when you install a lock in the different devices.

To remove the lock insert:

1. The lock must be in the appropriate position (**C** in Figure 21).
2. To remove the lock insert, place the brass installation-removal key (**C** in Figure 20) fully into the lock until you hear it click into place.

Note: There are two installation-removal keys. Use the one that you can insert into the lock insert.

3. Pivot the brass key slightly downward while pulling the lock insert out of the cylinder until the insert is disengaged from the cylinder.

Note: The brass key and the lock insert come out of the lock cylinder together. Pressing downward or sideways on the brass key as you pull makes it easier for the lock insert to come out along with the brass key.

4. Remove the brass key.

To install the lock insert:

1. Place the aligner into the empty cylinder, and gently turn the aligner until you feel it go into the slot at the bottom of the lock cylinder. Turn it to the appropriate position (**C** in Figure 21 on page 21).
2. Push the lock insert into the empty lock cylinder until it is flush with the top of the cylinder.
3. Hold the lock insert in place with your finger, and remove the brass key.
4. Test the lock to be sure it operates correctly with the keys.

Removing and replacing the blank lock insert

To remove the blank lock insert:

1. Insert the blank lock insert handle into the blank lock insert.
2. Using the blank insert handle, turn the locking screw counterclockwise until the insert can be removed from the cylinder.
3. When replacing the blank lock insert, switch the lock to the service position (**C** in Figure 21 on page 21).
4. Hold the blank lock insert so that the lug is aligned with the slot.
5. Push the blank lock insert into the empty lock cylinder until it is flush with the top of the lock cylinder.
6. Use the blank lock insert handle to turn the locking screw clockwise until it reaches the bottom of the hole. Do not overtighten.

To replace the blank lock insert, reverse this procedure.

Chapter 3. Point-of-sale displays

Display symptoms	23
Service procedures for 40-character VFD	24
Removing and replacing the 40-character VFD	24
Removing, replacing, and cleaning the VFD lens	25
Removing and replacing the 40-character LCD	26
Removing and replacing the character/graphics display	27
Service procedures for CRTs	28
Removing and replacing the post-mounted CRT	28
Removing and replacing the wedge-mounted CRT	29
Removing and replacing the table-mounted CRT	30
Removing and replacing the CRT mounting plate	30
Removing and replacing the CRT post mount attached to the counter.	31
Removing and replacing the table mount attached to the post	32

Refer to your Hardware Service Guide for problem determination and test procedures for displays. If necessary, replace the display.

Note: For detailed information about the SurePoint Solution display, refer to the *4820 SurePoint Solution: Installation and Service Guide*.

DANGER

To avoid a shock hazard:

- **Do not connect or disconnect any cables or perform installation, maintenance, or reconfiguration of this product during an electrical storm.**
- **The power cord must be connected to a properly wired and grounded receptacle.**
- **Any equipment to which this product will be attached must also be connected to properly wired receptacles.**

DANGER

When possible, use one hand to connect or disconnect signal cables to prevent a possible shock from touching two surfaces with different electrical potentials.

Note: Translations of these safety notices are available in Appendix C, "Safety information," on page 133.

Display symptoms

You must use your Hardware Service Guide to determine that a display is the cause of the failure.

Use Table 4 to determine the repair action for a display.

Table 4. Repair actions for display problems

Symptom	Repair actions
Incorrectly displayed character or device offline error.	<ol style="list-style-type: none"> 1. Check the voltage output of the powered USB cable (see "Voltage for USB connectors" on page 124). <ul style="list-style-type: none"> • If the voltages are correct, replace the display. • If the voltages are incorrect, replace the cable with a known good cable. <ul style="list-style-type: none"> – If the new cable fails to produce the correct voltage, refer to your Hardware Service Guide for information about servicing the system unit. – If the new cable produces the correct voltage then the first cable needs to be replaced. 2. Replace the display.
Totally blank display.	<ol style="list-style-type: none"> 1. Check that the Store System unit is on. 2. Check the voltage output of the powered USB cable (see "Voltage for USB connectors" on page 124). <ul style="list-style-type: none"> • If the voltages are correct, replace the display. • If the voltages are incorrect, replace the cable with a known good cable. <ul style="list-style-type: none"> – If the new cable fails to produce the correct voltage, refer to your Hardware Service Guide for information about servicing the system unit. – If the new cable produces the correct voltage then the first cable needs to be replaced. 3. Replace the display.

Service procedures for 40-character VFD

Use these procedures to repair the 40-character vacuum fluorescent display (VFD).

Removing and replacing the 40-character VFD

To remove the 40-character VFD:

1. Disconnect the display cable.

Note: For illustration, a single-sided display is shown. The yoke for a double-sided display is taller than the yoke for a single-sided display. However, the removal procedure is similar for both.

2. Gently spread the arms of the yoke open slightly, and slide the display out of the yoke. Pry the yoke with a tool, if necessary.
3. Unplug the display cable from the display.

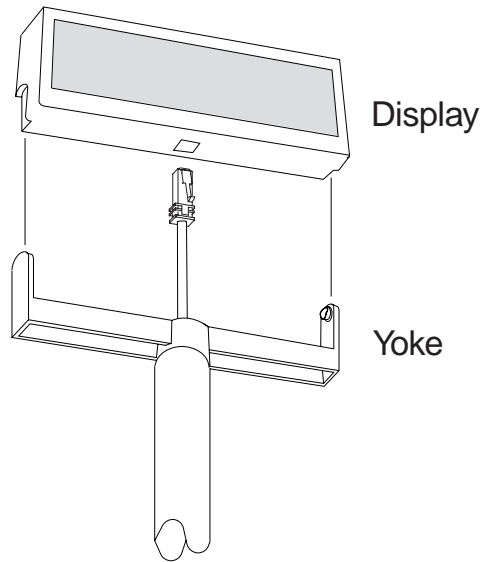

Figure 22. Removing and replacing the display

To replace the 40-character VFD, reverse this procedure.

Removing, replacing, and cleaning the VFD lens

To remove, clean, and replace the VFD lens:

1. Remove the display from the yoke (see "Removing and replacing the 40-character VFD" on page 24).
2. At the bottom of the display, press in on the plastic grille at the locations illustrated by the arrows in Figure 23, and snap the lens frame free from the display. **Do not** spray the cleaning solution into the display.

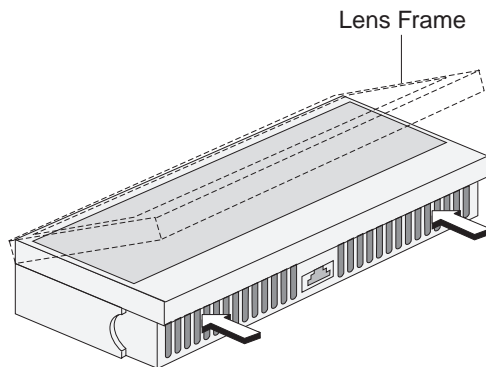

Figure 23. Removing the frame

3. Use a soft cloth that is dampened with a mild cleaning solution to clean the display glass and the lens.
4. To remove the lens from the frame for replacement, flex the frame outward (as shown by the arrows in Figure 24 on page 26), and snap the lens out.

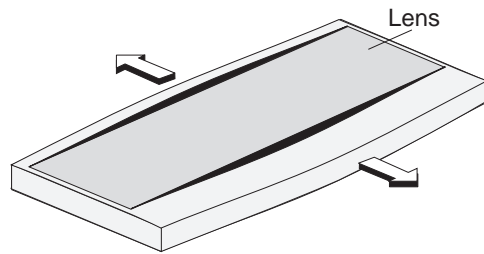

Figure 24. Removing the lens

5. Place the replacement lens into the frame from the outside, and snap it into position in the frame.
6. Snap the frame onto the display, and place the display into the yoke.

Removing and replacing the 40-character LCD

Note: Two displays can be stacked on a single post. They can face toward the front or the rear.

To remove the 40-character liquid crystal display (LCD):

1. Disconnect the display cable from the system unit.
2. Remove the post cap from the top of the post, and rotate the display away from you to a horizontal position (see the center section in Figure 25).

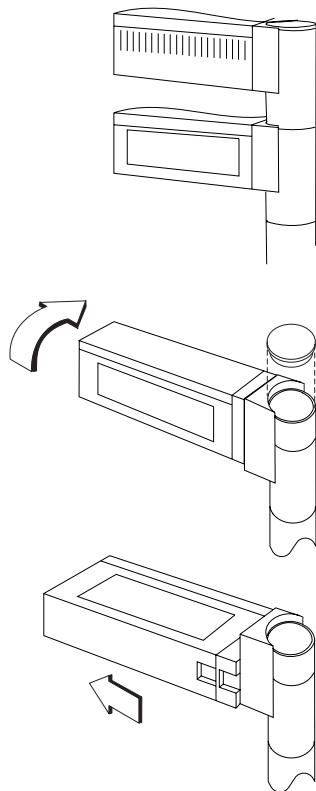

Figure 25. Disassembling the display

3. Slide the display away from the post.

4. Disconnect the cable from the display (see Figure 26).

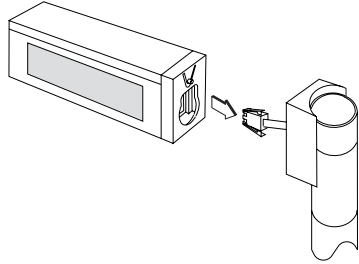

Figure 26. Disconnecting the display cable from the post

5. Remove the display by sliding it out of the holder (see Figure 27).

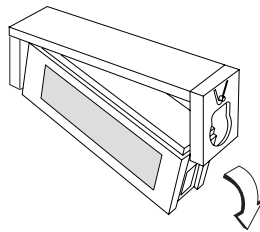

Figure 27. Sliding the display out of the holder

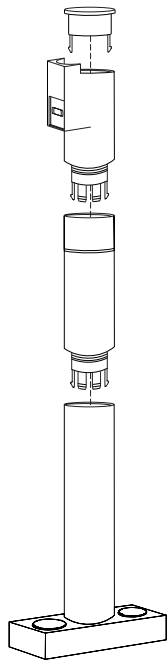

Figure 28. Assembling and disassembling the post

To replace the 40-character LCD, reverse this procedure.

Removing and replacing the character/graphics display

To remove the character/graphics display:

1. Disconnect the display cable.

-
2. Gently spread the arms of the yoke (**1**) open slightly, and slide the display (**2**) out of the yoke. Pry the yoke with a tool, if necessary.
3. Unplug the display cable from the display.

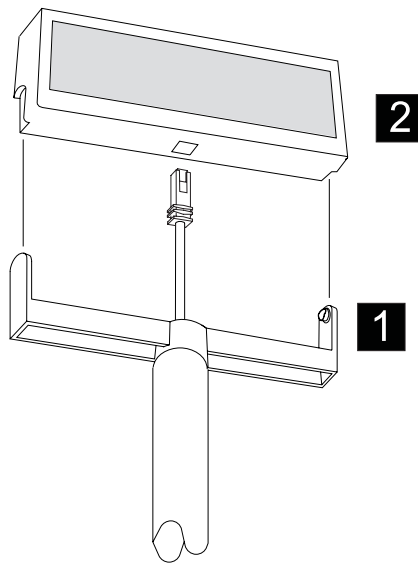

Figure 29. Removing and replacing the character/graphics display

To replace the character/graphics display, reverse this procedure.

Service procedures for CRTs

The 9-in. monochrome cathode ray tubes (CRTs) that are manufactured by IBM contain no repairable parts. If the CRT fails, you must replace it.

Removing and replacing the post-mounted CRT

To remove the post-mounted CRT:

1. Unplug the system unit power cord.
2. Disconnect the CRT power cord and CRT signal cable.
3. Remove the screw from under the arm of the post mount. The screw attaches the swivel mount to the top of the post mount (see Figure 30 on page 29).

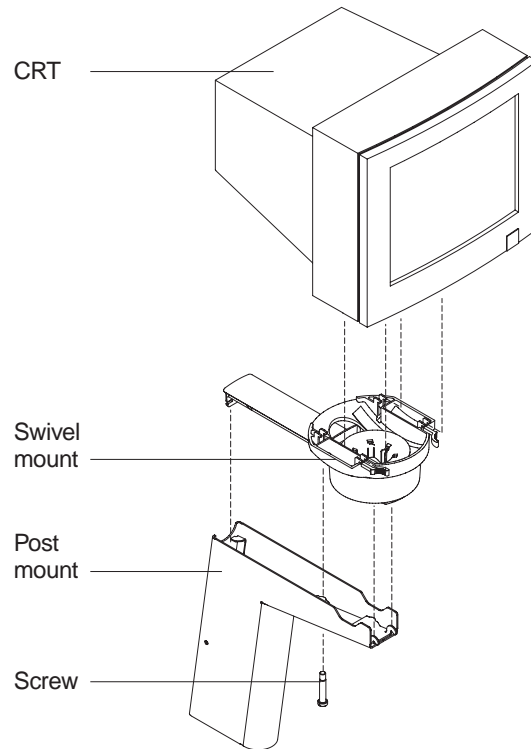

Figure 30. Post-mounted CRT

4. Slide the CRT and the swivel mount forward until the swivel mount disconnects from the post mount.
5. Carefully draw the CRT power cord and CRT signal cable up through the post.
6. Set the CRT and swivel mount upside down on a convenient work space.
7. Press the tabs on the base of the swivel mount, and slide the swivel mount back until it disconnects from the CRT.
8. Carefully pull the CRT power cord and CRT signal cable through the swivel mount.

To replace a post-mounted CRT, reverse this procedure. If you route the power cord and signal cable through the notch in the rear of the swivel mount cup, pull gently on the cables to minimize the size of the loop that is outside the cup.

Removing and replacing the wedge-mounted CRT

To remove the wedge-mounted CRT:

1. Disconnect the system unit power cord.
2. Disconnect the CRT power cord and CRT signal cable.
3. Turn the CRT and wedge mount upside down.
4. Unlatch the latching tabs, and slide the wedge mount rearward to disconnect it from the CRT (see Figure 31 on page 30).

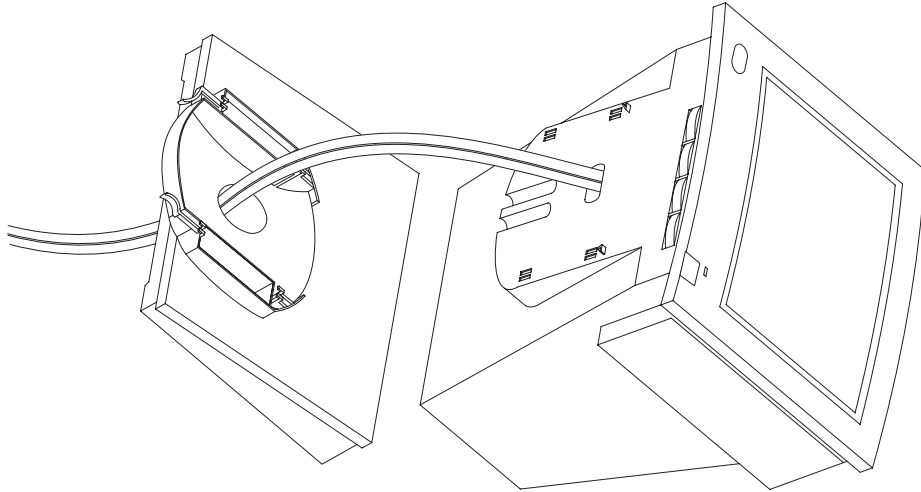

Figure 31. Location of the power cord and video cable for a wedge-mounted monochrome CRT

5. Carefully pull the CRT power cord and CRT signal cable through the wedge mount (see Figure 31).

To replace the wedge-mounted CRT, reverse this procedure.

Removing and replacing the table-mounted CRT

To remove the table-mounted CRT:

1. Disconnect the system unit power cord.
2. Disconnect the CRT power cord and CRT signal cable.
3. Cut the tie wraps that secure the CRT to the table mount.
4. Lift the CRT off of the table mount. Carefully pull the CRT power cord and CRT signal cable up through the post mount.

To replace the table-mounted CRT, reverse this procedure.

Removing and replacing the CRT mounting plate

If you use a CRT that is attached to a short post mount, you can attach the post mount to either the counter (see “Removing and replacing the CRT post mount attached to the counter” on page 31) or to a mounting plate.

To remove the CRT mounting plate:

1. Disconnect the system unit power cord.
2. Disconnect the CRT power cord and CRT signal cable.
3. Remove the CRT from the post mount (see “Removing and replacing the post-mounted CRT” on page 28).
4. Turn the post mount and mounting plate upside down on a convenient working space.
5. Remove the four screws that attach the mounting plate to the bottom of the post mount (see Figure 32 on page 31).

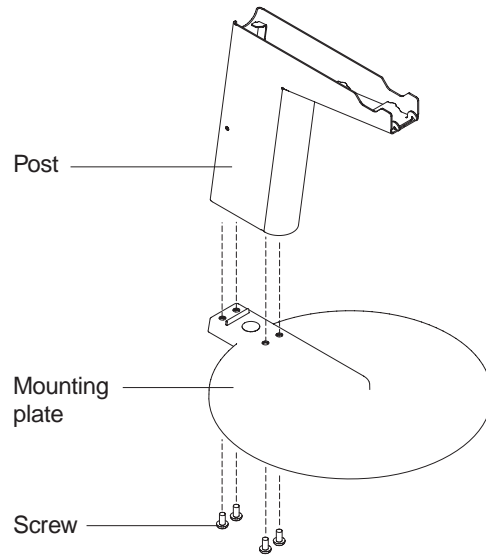

Figure 32. Mounting plate for CRT that is mounted on short post

Removing and replacing the CRT post mount attached to the counter

To remove the CRT post mount that is attached to the counter:

1. Disconnect the system unit power cord.
2. Disconnect the CRT power cord and CRT signal cable.
3. Remove the CRT from the post mount (see "Removing and replacing the post-mounted CRT" on page 28).
4. Remove the four screws that attach the post mount to the counter (see Figure 33 on page 32).

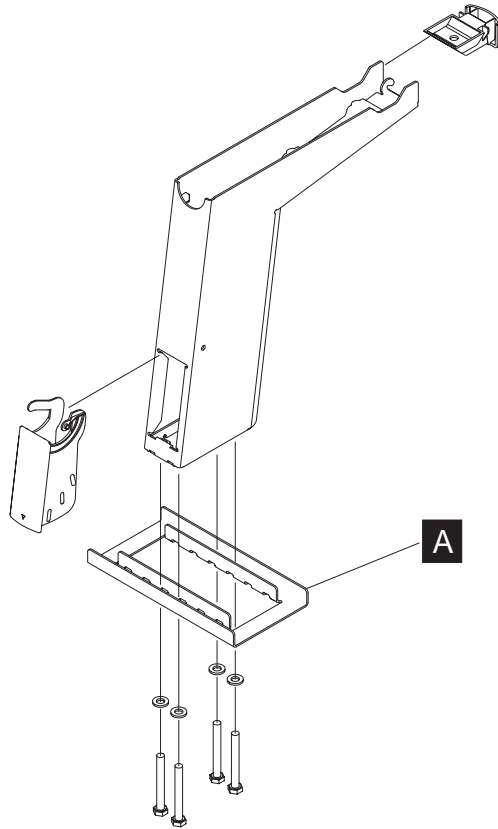

Figure 33. Attaching CRT to the counter

To reattach a CRT post mount to the counter, reverse this procedure.

Note: Be sure that you install the stiffener (**A** in Figure 33) when reattaching the post mount. If the nut inserts in the post mount are not self-locking, use the lock washers that are provided.

Removing and replacing the table mount attached to the post

To remove the CRT table mount from the post mount:

1. Disconnect the system unit power cord.
2. Disconnect the CRT power cord and CRT signal cable.
3. Remove the CRT from the table mount (see “Removing and replacing the post-mounted CRT” on page 28).
4. Remove the two screws that attach the table mount to the post mount (see Figure 34 on page 33).

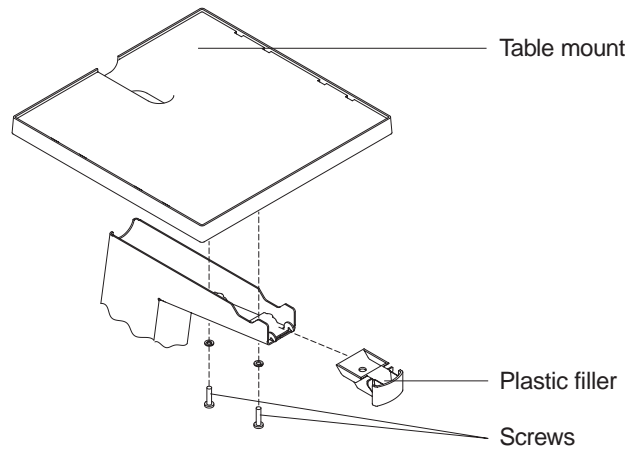

Figure 34. Table mount attached to post mount

5. Lift the table mount off from the post mount. Remove the plastic filler.

To reattach the CRT post mount to the counter, reverse this procedure.

Chapter 4. Point-of-sale keyboards

Keyboard types	36
Attaching the cables to the system unit	37
Securing IBM USB POS keyboard cables	37
Securing the cable using cable ties	38
Keyboard messages	38
Keyboard/pointer symptoms	38
Using the joystick on the PS/2 ANPOS keyboard with integrated pointing device	40
Device driver considerations	40
Ergonomic considerations	41
Removing and replacing CANPOS keyboard components	42
Removing and replacing the CANPOS keypad assembly	43
Removing and replacing the CANPOS keyboard logic card	45
Removing and replacing the CANPOS keyboard with MSR	46
Removing and replacing retail POS keyboard components	48
Removing and replacing the keypad assembly	50
Removing and replacing the MSR	50
Removing and replacing the MSR flexible cable	51
Removing and replacing the LCD	52
Removing and replacing the keyboard logic card	52
Removing and replacing the lock insert	53
Removing and replacing the blank lock insert	53
Removing and replacing USB keyboard-V components	54
Opening the cover	54
Removing and replacing the logic board	54
Removing and replacing the magnetic stripe reader	56
Removing and replacing the speaker assembly	57
Removing and replacing the keyboard matrix unit	58
Removing and replacing the top cover assembly	59
Removing and replacing USB PLU keyboard/display components	59
Opening the cover	59
Removing and replacing the VFD assembly	60
Removing and replacing the keyboard matrix unit	61
Removing and replacing the logic board	62
Removing and replacing the bottom cover assembly	64
Removing and replacing the top cover assembly	64
USB PLU extension box	65

This chapter contains repair and usage information for keyboards that can be used with Store System units.

DANGER

To avoid a shock hazard:

- **Do not connect or disconnect any cables or perform installation, maintenance, or reconfiguration of this product during an electrical storm.**
- **The power cord must be connected to a properly wired and grounded receptacle.**
- **Any equipment to which this product will be attached must also be connected to properly wired receptacles.**

DANGER

When possible, use one hand to connect or disconnect signal cables to prevent a possible shock from touching two surfaces with different electrical potentials.

Note: Translation of these safety notices are available in Appendix C, "Safety information," on page 133.

Keyboard types

Several kinds of keyboards are available with a variety of features. Most have a built-in magnetic stripe reader (MSR), and one has a liquid crystal display (LCD). Figure 35 shows the keyboard types that are available for IBM Store Systems.

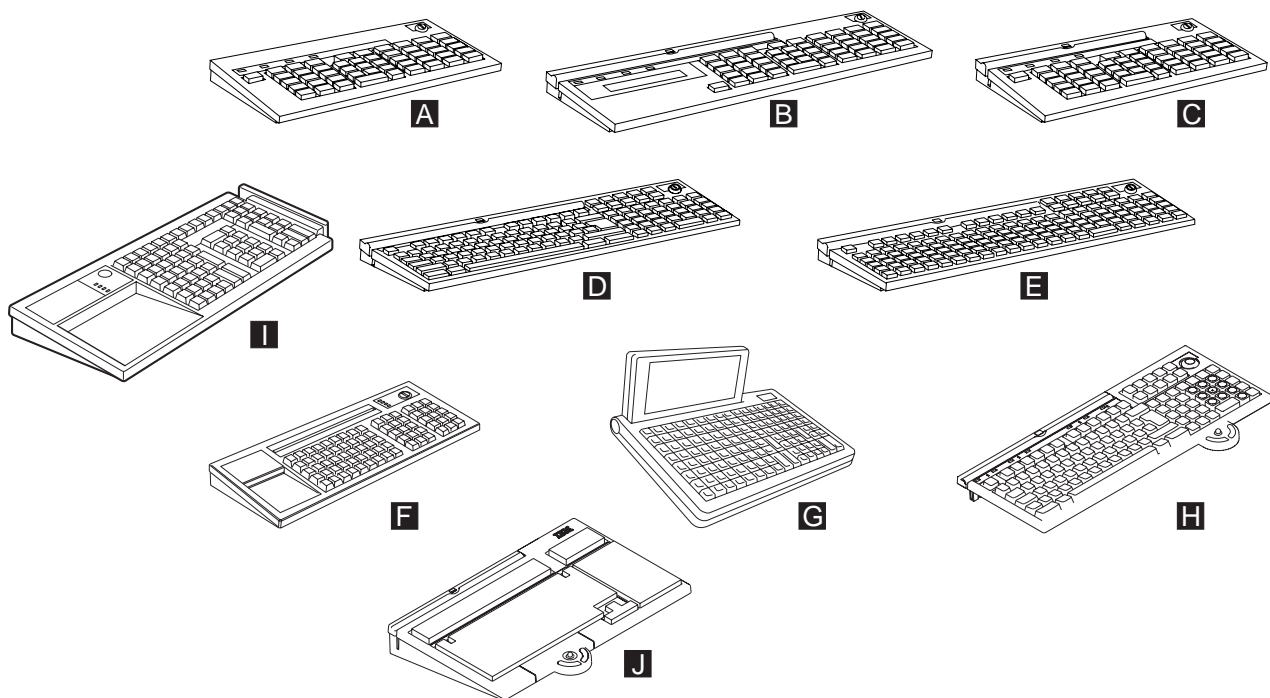

Figure 35. Keyboard types for IBM Store Systems

Figure 35 shows the types of keyboards as follows:

A	50-key keyboard
B	50-key keyboard with magnetic stripe reader (MSR) and display
C	50-key keyboard with MSR, 50-key keyboard with JUCC MSR
D	ANPOS keyboard, ANKPOS keyboard
E	133-key keyboard with MSR
F	Keyboard-V
G	PLU keyboard
H	PS/2 ANPOS keyboard with integrated pointing device
I	Keyboard VII
J	CANPOS keyboard

Attaching the cables to the system unit

The POS I/O cables developed by IBM all have latches or screws to secure them to the system unit and, thus, prevent accidental disconnection. Cables are sometimes used that do not provide latches or screws, such as standard PC USB cables. IBM Store Systems provide several methods to secure such cables.

Securing IBM USB POS keyboard cables

If you ordered a USB POS keyboard from IBM with a standard PC USB connection, the cable ships with a locking clip. Figure 36 shows the steps to secure the cable using the clips and brackets.

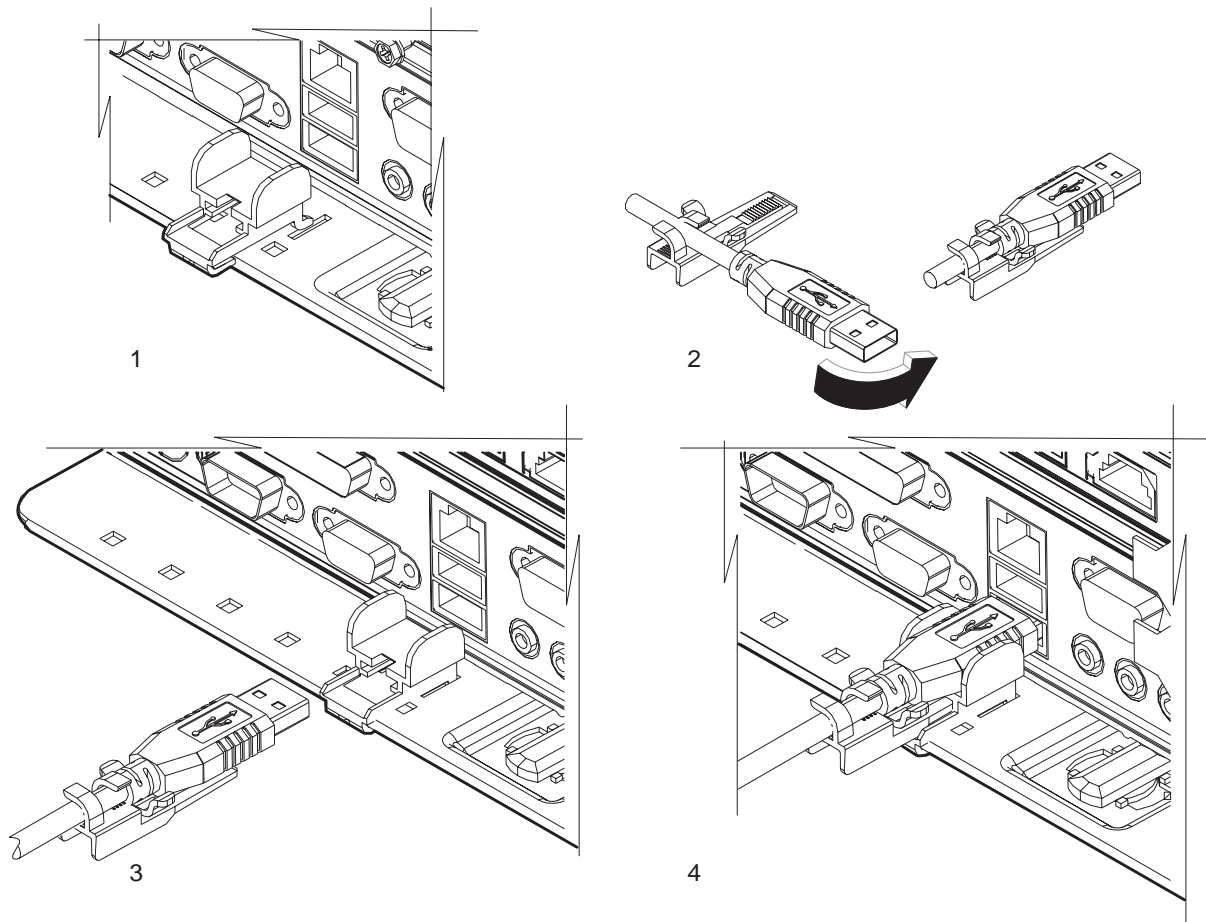

Figure 36. Pictorial steps to attach the cable with clips and brackets

1. As shown in picture 1, align the clip bracket with the holes provided on the rear base of the system unit. Press down and push forward on the bracket to lock into place.
2. As shown in picture 2, align the USB cable with the cable clip. Holding the clip and the cable together, rotate the clip clockwise around the cable to connect the clip to the cable.
3. As shown in picture 3, slide the USB cable and attached clip into the bracket.
4. As shown in picture 4, connect the cable to the system unit. Be sure to push the cable and clip assembly firmly against the edge of the system unit to secure the connection.

Securing the cable using cable ties

Without a provision to latch or screw a cable in position, you can secure the cable using cable ties, as follows:

1. Plug the cable into the system unit. Loosely place the cable cord to either the left or right side of the connector.
2. As shown in Figure 37, wrap the cable tie around the cable cord and through the hole located in the base of the system unit. Tighten the cable tie to secure. Your connection should place no pressure on the cable connector, but instead secure the cable cord to the system unit.

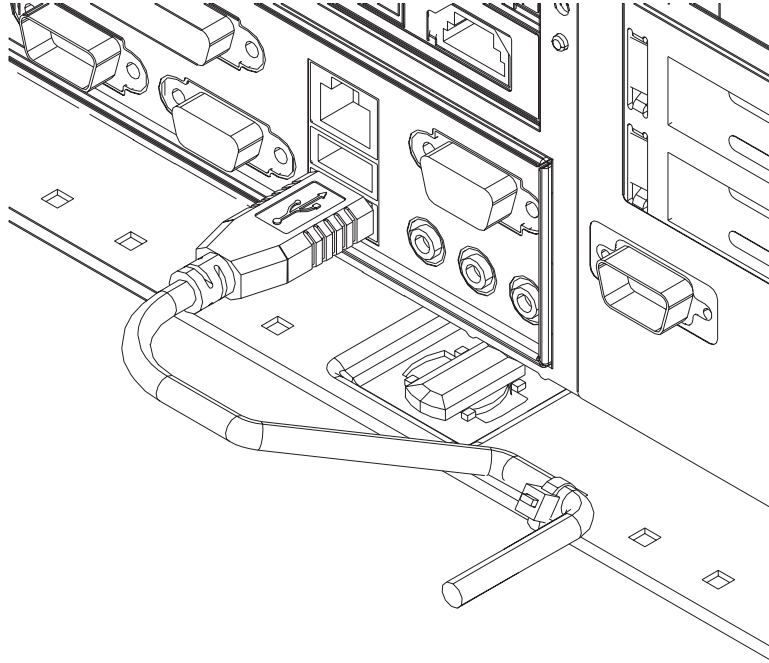

Figure 37. Securing the cable with cable ties

Keyboard messages

Use your Hardware Service Guide to identify keyboard error messages.

Note: When you use a keyboard that has a **Ctrl** key, the **S1** and **S2** functions require a combination of two keys. First press and hold the **Ctrl** key; then press the **S1** or **S2** key.

Keyboard/pointer symptoms

You must use your Hardware Service Guide to determine whether the keyboard is the cause of the failure.

Use Table 5 to determine the failing FRU.

Table 5. Repair actions for keyboard/pointer problems

Symptom	Repair actions
One or several keyboard keys is failing (keyboard is operational).	<ol style="list-style-type: none"> 1. Replace the keypad assembly (see "Removing and replacing the keypad assembly" on page 50). 2. Replace the keyboard logic card (see "Removing and replacing the keyboard logic card" on page 52).
Keyboard tone is failing.	Replace the keyboard logic card (see "Removing and replacing the keyboard logic card" on page 52).
All keyboard lights are on (keyboard is not operational).	Replace the keyboard logic card (see "Removing and replacing the keyboard logic card" on page 52).
One or more keyboard lights are failing (keyboard is operational).	<ol style="list-style-type: none"> 1. Replace the LED assembly. 2. Replace the keyboard logic card (see "Removing and replacing the keyboard logic card" on page 52).
All keyboard lights are failing (keyboard is not operational).	<ol style="list-style-type: none"> 1. Ensure that the USB cable is attached securely at the keyboard and the system unit. 2. Try a known operational I/O device and cable in the port where the keyboard is attached. If the device is operational, then continue checking the keyboard. If the device is not operational, then the port is not operational. 3. Replace the USB keyboard cable. 4. Replace the keyboard logic card (see "Removing and replacing the keyboard logic card" on page 52).
The manager lock does not turn with the key.	Replace the keypad assembly (see "Removing and replacing the keypad assembly" on page 50).
The manager lock turns with the key but is not detected by the test or application program.	Replace the keyboard logic card (see "Removing and replacing the keyboard logic card" on page 52).
The display in the combined keyboard/display is failing.	Replace the display (see "Removing and replacing the LCD" on page 52).
The card reader in the keyboard is failing.	<ol style="list-style-type: none"> 1. Replace the card reader (see "Removing and replacing the MSR" on page 50). 2. Replace the keyboard logic card (see "Removing and replacing the keyboard logic card" on page 52).

Table 5. Repair actions for keyboard/pointer problems (continued)

Symptom	Repair actions
The cursor responds sluggishly or does not move when using the PS/2 ANPOS keyboard with integrated pointing device.	<p>When the computer initially boots up, the cursor may respond sluggishly. After a few seconds, the device will calibrate itself. If the sluggishness persists, follow these steps:</p> <ol style="list-style-type: none"> 1. Push the joystick to its maximum deflection in each direction—up, down, left, and right—for 2-3 seconds in each direction. 2. If the problem is not resolved, then replace the keypad assembly.

Using the joystick on the PS/2 ANPOS keyboard with integrated pointing device

The PS/2 ANPOS keyboard with integrated pointing device, shown in Figure 38, provides a miniature joystick for controlling the cursor. The right and left mouse buttons allow you to select items and use click-and-drag functions.

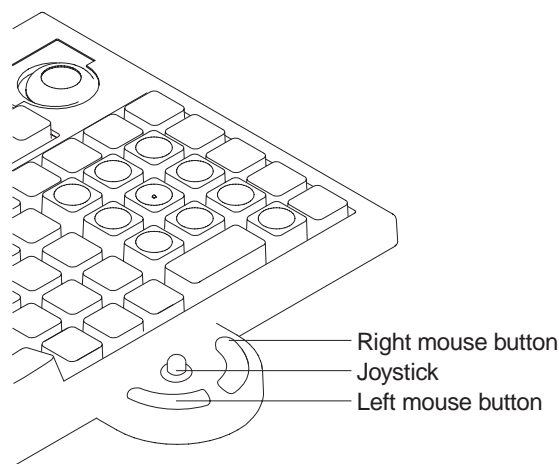

Figure 38. PS/2 ANPOS keyboard with integrated pointing device

To operate the device, apply pressure to the tip of the joystick in the direction of the desired cursor movement. The stick deflects slightly as you press it. The more the stick deflects, the faster the cursor moves.

Note: The redesigned cap (with the textured surface) for the keyboard pointing device (joystick) is a consumable item; the customer is responsible for cap replacement. If you have this style cap, replacement caps can be purchased by calling 1-800-IBM-CALL (1-800-426-2255) in the US and Canada. Customers outside the US and Canada should contact their IBM representative.

Device driver considerations

The integrated pointing device does not require a special driver. The device uses the standard PS/2-mouse driver that is shipped with the operating system.

Some mouse drivers allow you to adjust certain motion parameters. For the best performance, you should turn off acceleration. The other motion parameters do not affect the performance of the integrated pointing device.

Refer to the documentation for your operating system to obtain instructions about adjusting the device driver settings.

Ergonomic considerations

Use the stick in a way that is most comfortable for you. However, most people prefer to operate the stick in one of the following ways:

- With their forefinger while resting the third, fourth, and fifth fingers on the edge of the keyboard (see Figure 39).

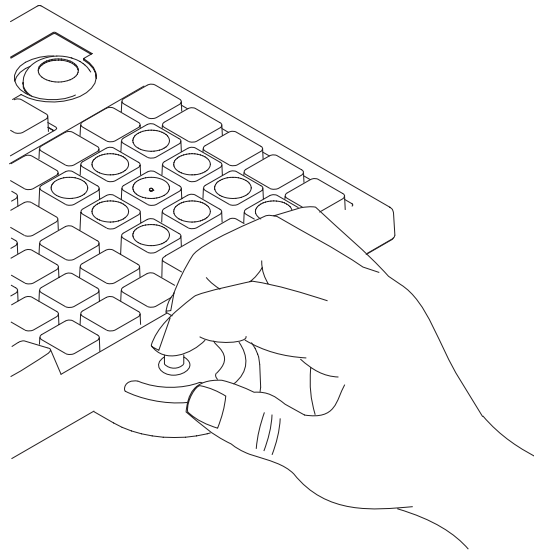

Figure 39. Resting finger positions

- With their thumb while pinching the device with the forefinger from below (see Figure 40 on page 42).



Figure 40. Thumb position

Note: Do not press downward too hard on the joystick or squeeze the device tightly between your thumb and forefinger. For your comfort, use a light touch on the joystick. Heavy, downward pressure on the stick causes the cursor to move more slowly.

Removing and replacing CANPOS keyboard components

Figure 41 shows the CANPOS keyboard and its components:

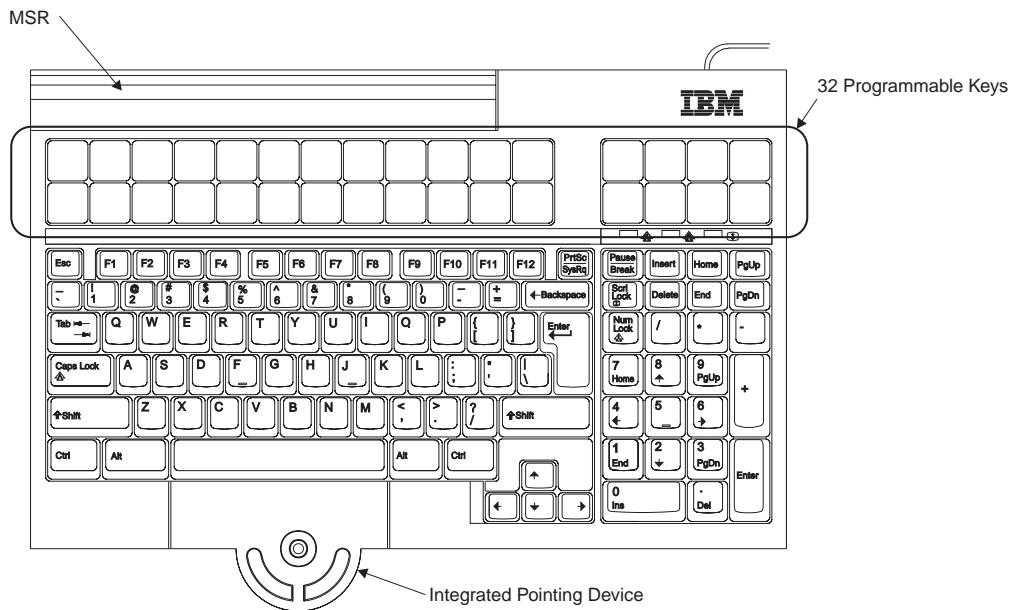

Figure 41. CANPOS Keyboard

Notes:

1. The redesigned cap (with the textured surface) for the keyboard pointing device (joystick) is a consumable item; the customer is responsible for cap

replacement. If you have this style cap, replacement caps (P/N 30R0037) can be purchased by calling 1-800-IBM-CALL (1-800-426-2255) in the US and Canada. Customers outside the US and Canada should contact their IBM representative.

2. FRUs for the keyboards listed in the following table are no longer available; the entire keyboard should be replaced. If you have one of these keyboards, you do not need to remove any keyboard components. See "Assembly 9: Keyboard, USB and RS-485, 50-key, with or without MSR" on page 90 for new keyboard FRU part numbers.

Keyboard P/N	Description	
54P8779	US English	no MSR
54P8780	UK English	
54P8781	French	
54P8782	Canadian French	
54P8783	Spanish	
54P8784	Brazilian Portuguese	
54P8785	German	
54P8786	US English	with MSR
54P8787	UK English	
54P8788	French	
54P8789	Canadian French	
54P8790	Spanish	
54P8791	Brazilian Portuguese	
54P8792	German	

Removing and replacing the CANPOS keypad assembly

You must remove the keyboard from the keyboard integration tray to service the keyboard.

1. To remove the keyboard from the keyboard integration tray, perform the following steps:
 - a. Remove the keyboard **E** from the keyboard integration tray by lifting the keyboard up and off the keyboard integration tray, as show in Figure 42 on page 44.

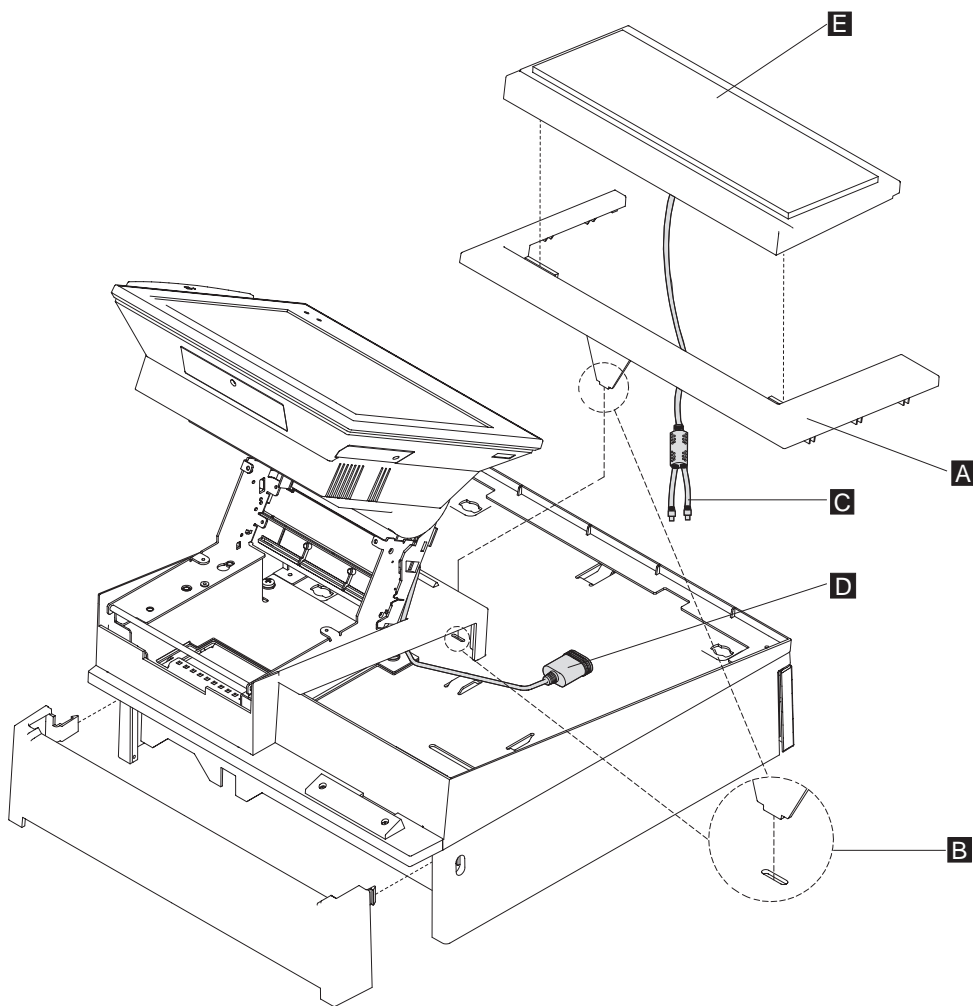

Figure 42. Removing the keyboard from the integration tray

- b. Remove the keyboard filler panel **A**. For reassembling, observe that the keyboard filler panel is inserted into the slot on integration tray, as show in exploded view **B**, as show in Figure 42.
 - c. Detach the keyboard cable **C** from the Y-cable **D**, if the Y-cable is used.
2. Replace the internal FRUs in the CANPOS keyboard keypad assembly:
 - a. Disconnect the cable from the rear of the keyboard.
 - b. Remove the three screws from the underside of the front edge of the keyboard.
 - c. Lift the front edge of the keyboard enough to access the cables inside the keyboard.
 - d. Disconnect all cables between the keypad assembly and the keyboard logic card. See Figure 43 on page 45 for cable callouts and locations.

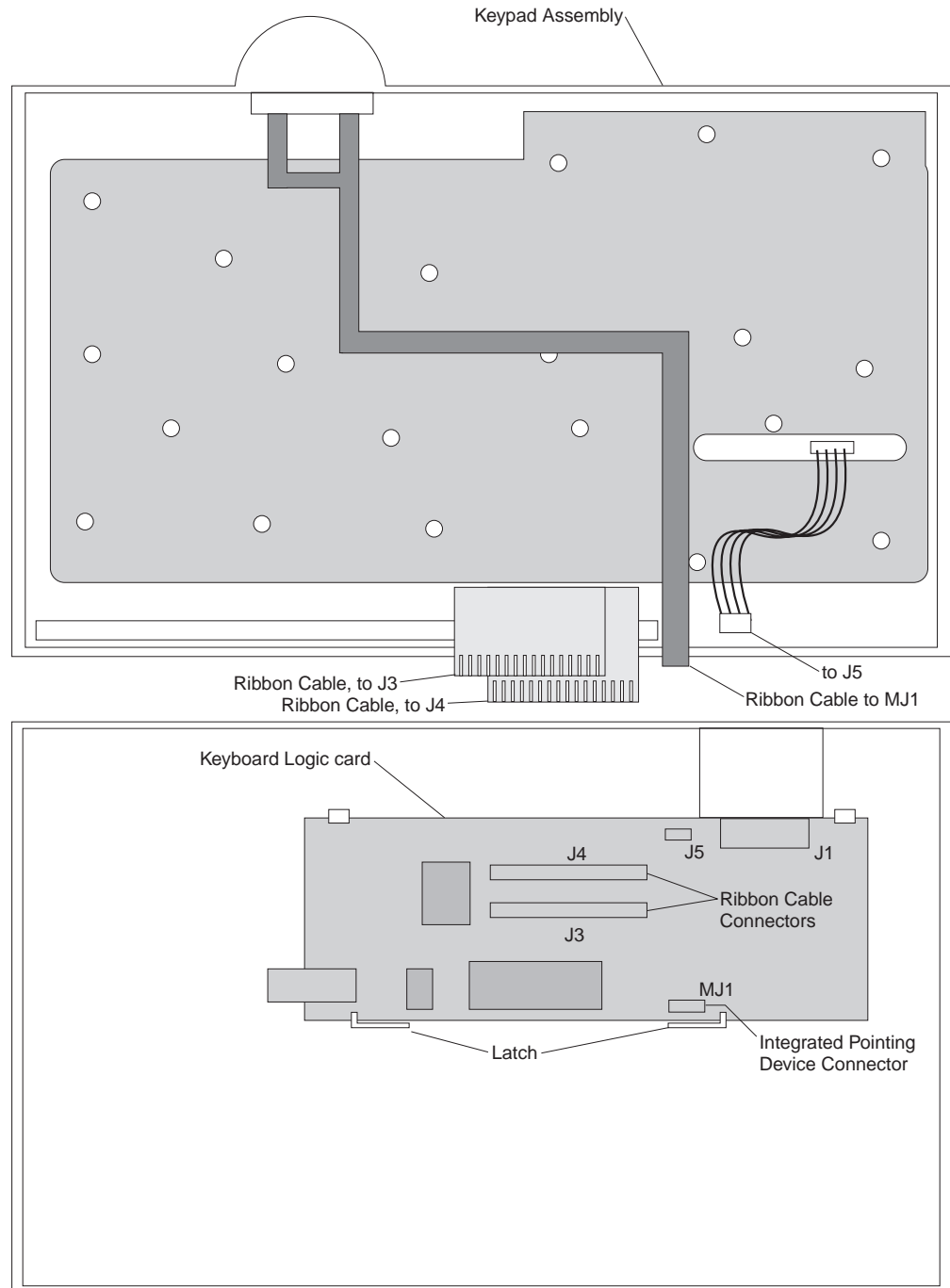

Figure 43. CANPOS keypad assembly without MSR

3. Lift and remove the keypad assembly.

To replace the keypad assembly, reverse these steps.

Removing and replacing the CANPOS keyboard logic card

To remove the keyboard logic card:

1. Remove the keypad assembly. See "Removing and replacing the keypad assembly" on page 50.

2. Pull the two card-retention latches away from the card, and lift the logic card out of the keyboard base. See Figure 43 on page 45 for card and latch locations.

To replace the logic card, reverse these steps. Contact the customer to use the CANPOS Keyboard Utility program to download the information about the 32 programmable keys to the CANPOS keyboard.

Removing and replacing the CANPOS keyboard with MSR

To remove the MSR:

1. Remove the keypad assembly. See “Removing and replacing the keypad assembly” on page 50.
2. Remove the two screws holding the MSR to the keypad assembly as shown in Figure 44 on page 47. Lift the MSR up and off of the two plastic guides on the keypad assembly.

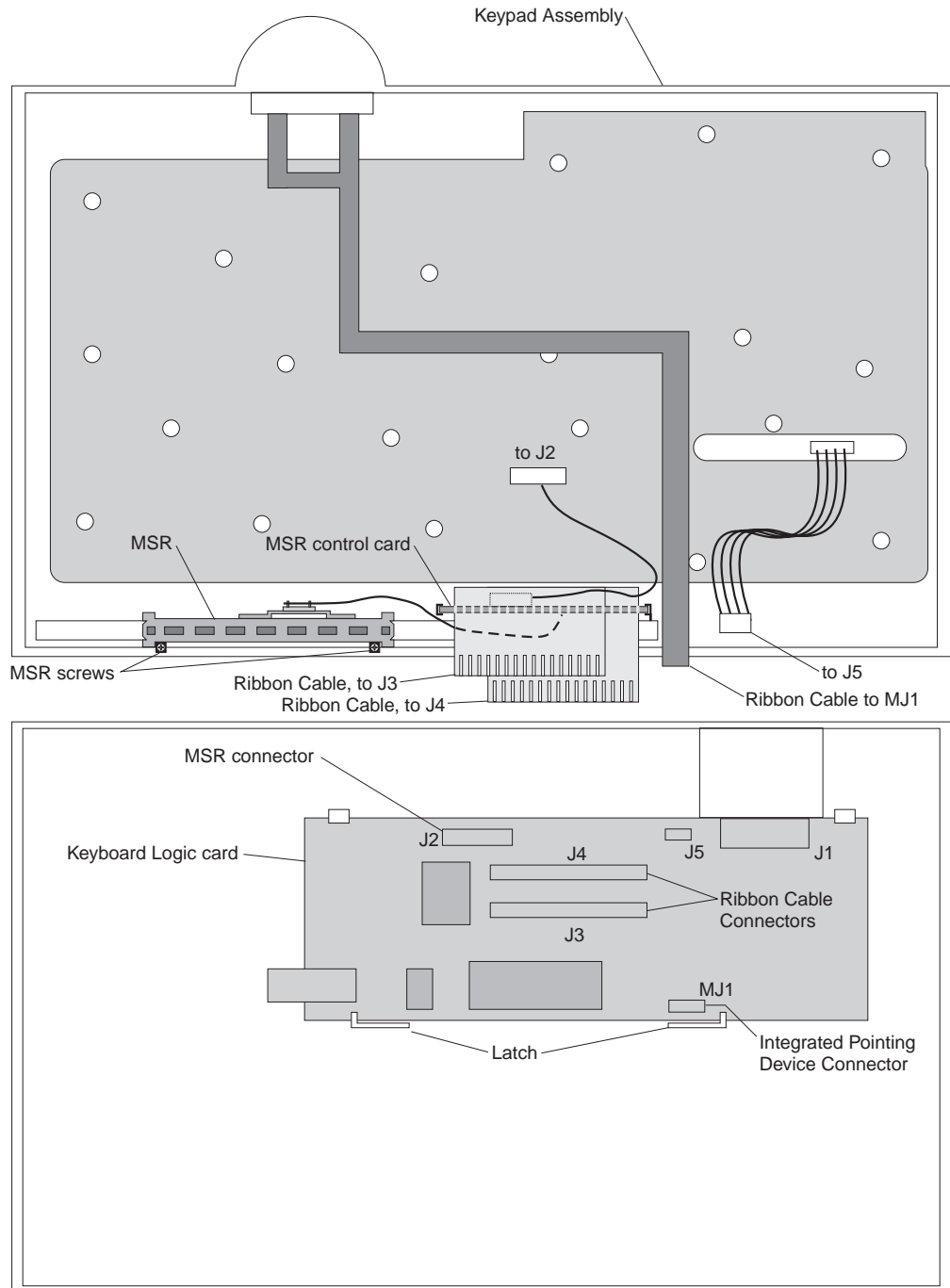

Figure 44. CANPOS keypad assembly with MSR

3. To remove the MSR control card, place a small slotted screwdriver between the metal keypad assembly and the bottom of the MSR control card **A**, and pry the control card up and off the two plastic guides as shown in Figure 45 on page 48.

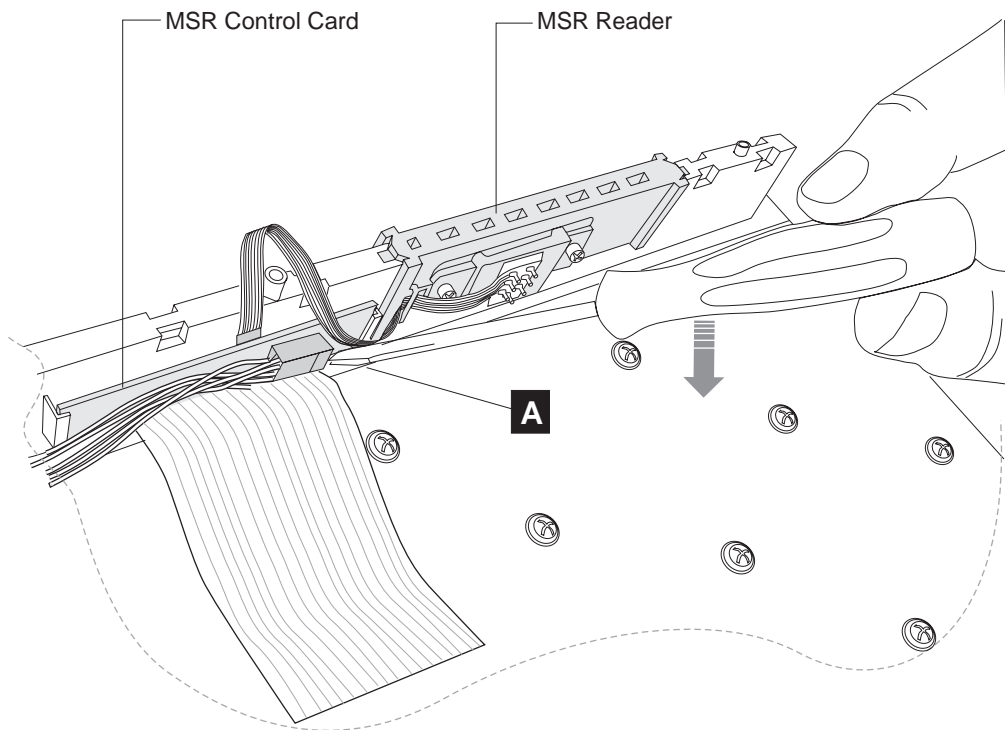

Figure 45. Removing the MSR control card

To replace the MSR:

1. Install the MSR control card onto the keypad assembly by inserting the control card into the two plastic guide, as shown in Figure 45.
2. Before installing the MSR onto the keypad assembly, route the thin ribbon cable from the MSR control card to the MSR under the plastic clip on the MSR.
3. Align the MSR's two screw-holes tabs with the screw holes on the keypad assembly, and slide the MSR into the two plastic guides. Install and tighten the two screws, as shown in Figure 44 on page 47.
4. Install the keypad assembly. See "Removing and replacing the keypad assembly" on page 50.

Contact the customer to use the CANPOS Keyboard Utility program to download the programmable MSR information to the CANPOS keyboard.

Removing and replacing retail POS keyboard components

Use the procedures in this section to repair keyboard components.

Figure 46 on page 49 shows the USB 50-key keyboard with MSR and LCD. The components for other USB keyboards are similar.

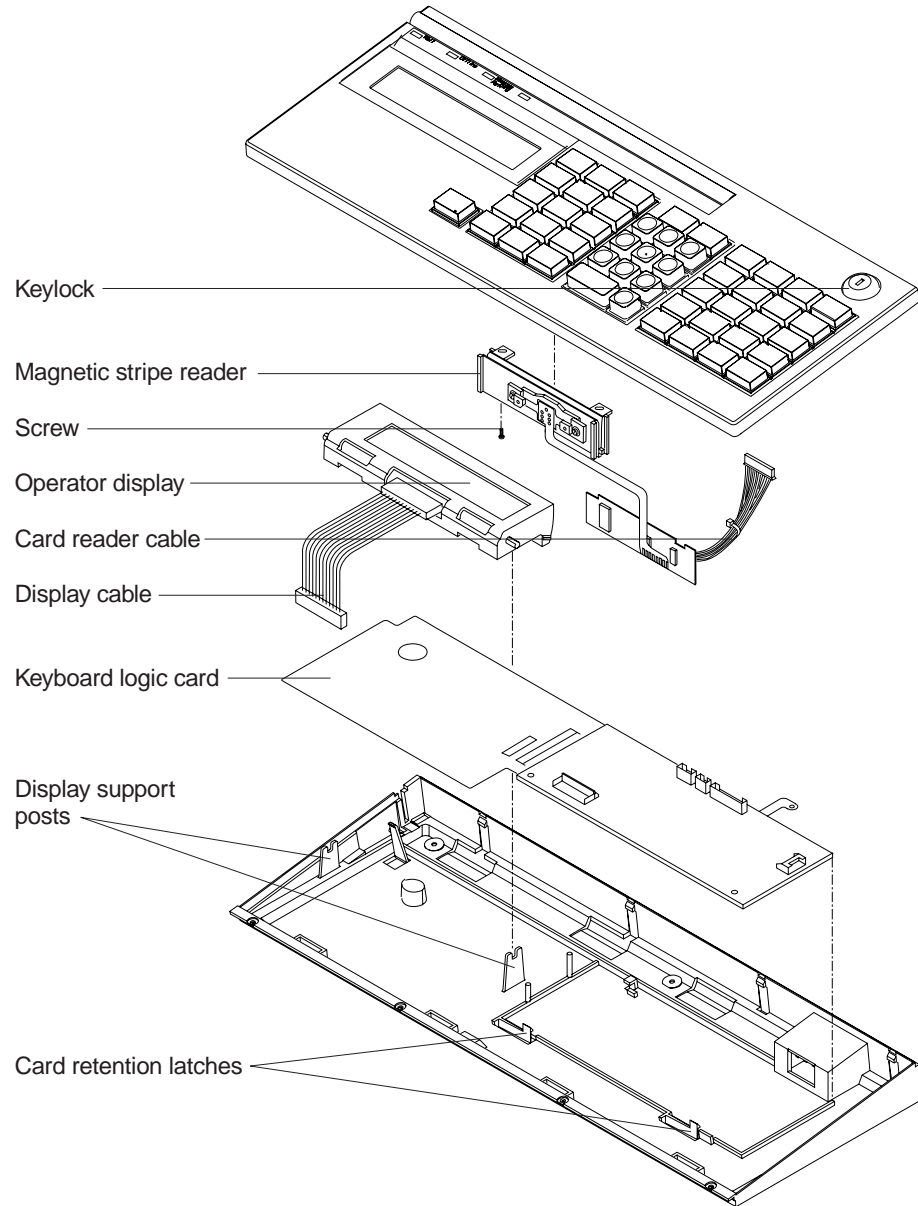

Figure 46. Removing keyboard components

Note: FRUs for the keyboards listed in the following table are no longer available; the entire keyboard should be replaced. If you have one of these keyboards, you do not need to remove any keyboard components. See “Assembly 8: CANPOS keyboard with integrated pointing device” on page 86 for new keyboard FRU part numbers.

Keyboard P/N	Language	Color
10J0902	US English	Pearl white/storm gray
10J0905	UK English	Pearl white/storm gray
10J0903	Spanish	Pearl white/storm gray
10J0904	French	Pearl white/storm gray
10J0793	US English	Pearl white/litho gray
10J0796	UK English	Pearl white/litho gray

Keyboard P/N	Language	Color
10J0795	French	Pearl white/litho gray
10J0794	Spanish	Pearl white/litho gray
14J0601	US English	Iron gray
14J0694	UK English	Iron gray
14J0696	French	Iron gray
14J0695	Spanish	Iron gray

Removing and replacing the keypad assembly

To remove the keypad assembly:

1. Disconnect the USB cable from the rear of the keyboard.
2. Remove the screws (3 or 4, depending on the type of keyboard) from the underside of the front edge of the keyboard (see Figure 47).

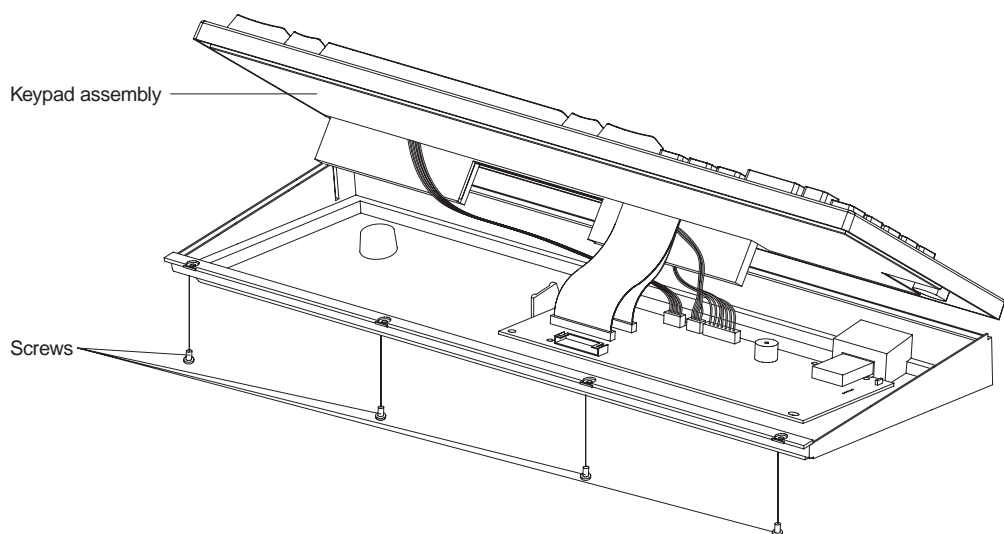

Figure 47. Removing the keypad assembly

3. Lift the front edge of the keyboard enough to access the cables underneath.
4. Disconnect all cables between the keypad assembly and the logic card.
5. Lift and remove the keypad assembly.
6. For keyboards that have a card reader, remove the reader before replacing the keypad assembly (see "Removing and replacing the MSR").

To replace the keypad assembly, reverse this procedure.

Removing and replacing the MSR

To remove the MSR:

1. Remove the keypad assembly (see "Removing and replacing the keypad assembly").
2. Disconnect the card reader cable (see Figure 41 on page 42).
3. Remove the screw holding the card reader (see Figure 41 on page 42).

To reassemble the MSR, reverse this procedure.

Removing and replacing the MSR flexible cable

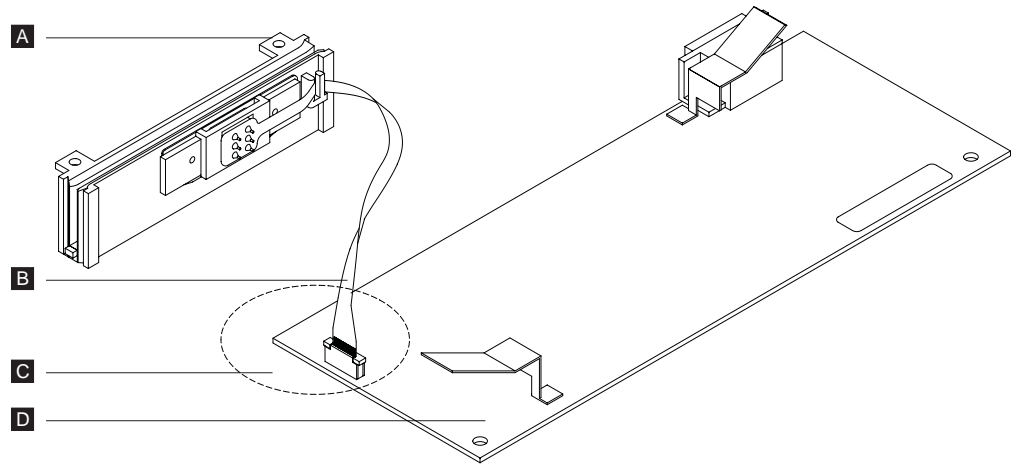

Figure 48. Example of MSR flexible cable assembly

Figure 48 shows the components of the MSR flexible cable assembly as follows:

- A** MSR assembly
- B** Flexible cable
- C** Connector area
- D** Logic board

To remove the MSR flexible cable:

1. Pull up on the connector holder to unlock the cable (see Figure 51 on page 52).
2. Remove the flexible cable from the connector (see Figure 50 on page 52).

To replace the MSR flexible cable:

1. Pull up on the connector holder (see Figure 49).

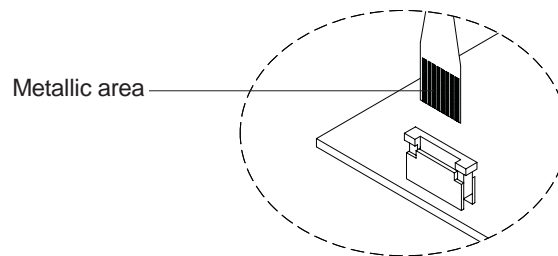

Figure 49. Removing the flexible cable from the connector holder

2. Insert the flexible cable into the connector, making sure that the shiny side is the position shown in Figure 50 on page 52.

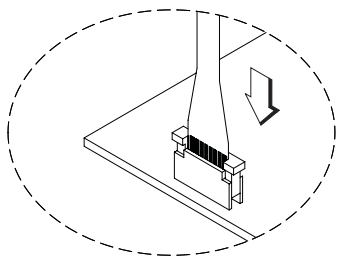

Figure 50. Inserting the flexible cable

3. Push down on the connector holder to lock the cable in place (see Figure 51).

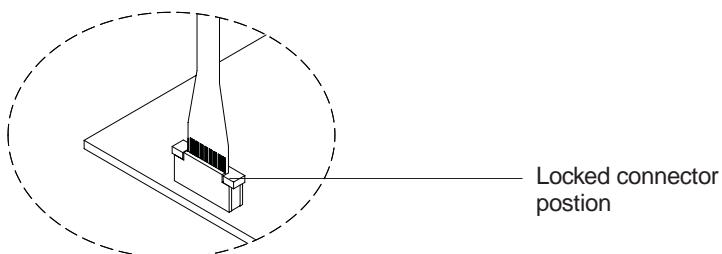

Figure 51. Locked connector position

Removing and replacing the LCD

To remove the LCD (operator display):

1. Remove the keypad assembly (see “Removing and replacing the keypad assembly” on page 50).
2. Disconnect the display cable (see Figure 41 on page 42).
3. Unsnap the display from the support posts (see Figure 41 on page 42).

To replace the keyboard display, reverse these steps.

Removing and replacing the keyboard logic card

To remove the keyboard logic card:

1. Remove the keypad assembly (see “Removing and replacing the keypad assembly” on page 50).
2. If the keyboard has a display, remove the display (see “Removing and replacing the LCD”).
3. Pull the two card-retention latches away from the card, and lift the logic card out of the keyboard base (see Figure 41 on page 42).

To replace the logic card, reverse this procedure.

Removing and replacing the lock insert

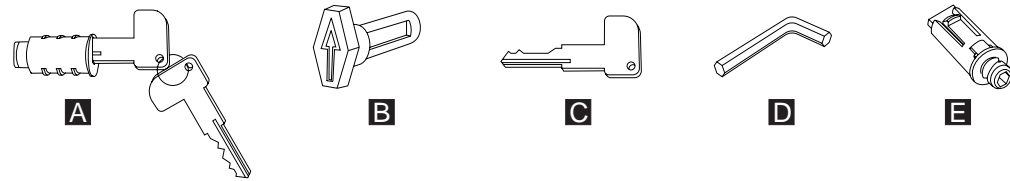

Figure 52. Lock accessories

Figure 52 shows the components of the lock insert assembly as follows:

- A** Lock insert and keys
- B** Aligner. This tool is used to ensure that the slot at the bottom of the lock cylinder aligns with the lock insert being installed. For the keyboard, the arrow on the aligner should point away from you. (The arrow points in different directions for other types of devices.)
- C** Brass installation-removal key
- D** Blank lock installation handle
- E** Blank lock insert

To remove the lock insert:

1. The lock must be in the unlocked position.
2. Insert the brass installation-removal key fully into the lock until it clicks into place.
3. Pivot the brass key slightly downward while pulling the lock insert out of the cylinder until the insert is disengaged from the cylinder.

Note: The brass key and the lock insert come out of the lock cylinder together. Pressing downward or sideways on the brass key as you pull makes it easier for the lock insert to come out along with the brass key.

4. Remove the brass key.

To replace the lock insert:

1. The lock insert fits all of the way into the lock cylinder only when the slot in the bottom of the cylinder and the lug on the end of the insert are both in alignment. If necessary, insert the aligner tool (see Figure 52) into the lock cylinder and rotate it until you feel it engage the slot at the bottom of the cylinder, then turn the aligner tool until the arrow points up.
2. Remove the key that came with the new lock insert.
3. Push the brass installation-removal key into the lock insert. Be sure the key is fully inserted.
4. With the brass installation-removal key still in the lock insert, push the lock insert fully into the lock cylinder.
5. While holding the lock insert in place with your finger, remove the installation-removal key.
6. Test the lock using the keys that came with the insert to be sure that the lock operates correctly.

Removing and replacing the blank lock insert

To remove the blank lock insert:

1. Insert the blank lock insert handle into the blank lock cylinder (see Figure 52).

2. Using the blank insert handle, turn the locking screw counterclockwise until the insert can be removed from the cylinder.
3. When replacing the blank lock insert, the lug on one end of the insert must be aligned with the slot in the bottom of the lock cylinder. Hold the blank lock insert so that the lug is aligned with the slot.
4. Push the blank lock insert into the empty lock cylinder until it is flush with the top of the lock cylinder.
5. Use the blank lock insert handle to turn the locking screw clockwise until it reaches the bottom of the hole. Do not overtighten.

To replace the blank lock insert, reverse this procedure.

Removing and replacing USB keyboard-V components

This section describes procedures to repair the USB keyboard-V.

Opening the cover

To open the cover:

1. Set the USB keyboard-V upside-down on a flat surface.
2. Remove the eight screws (see **A** in Figure 53).

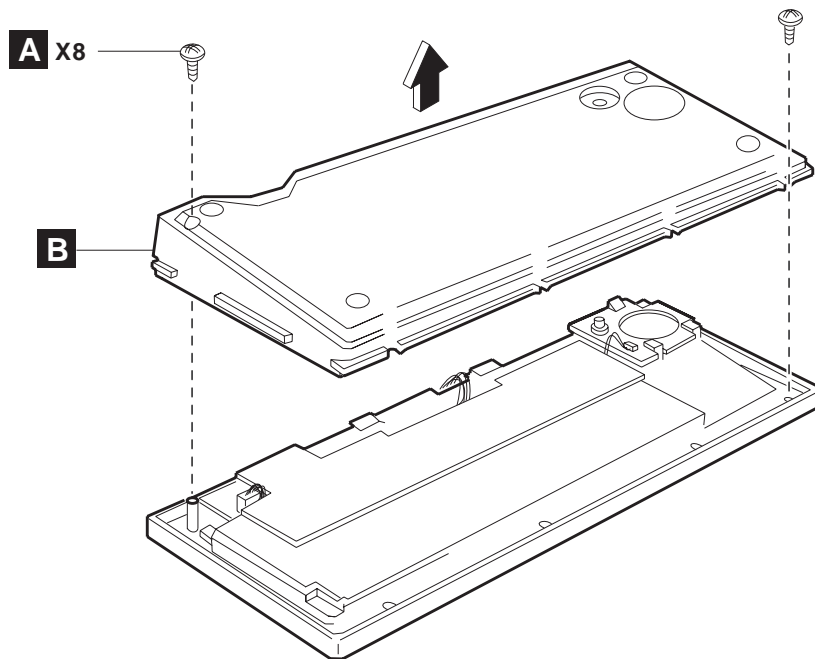

Figure 53. USB keyboard-V components – part 1

3. Lift the bottom cover assembly (see **B** in Figure 53).
4. Remove the bottom cover.

Removing and replacing the logic board

To remove the logic board:

1. Use the procedure in “Opening the cover” to remove the bottom cover assembly.

2. Disconnect the cable from the magnetic stripe reader unit (see **C** in Figure 54). Do not disconnect the cable from the logic board.

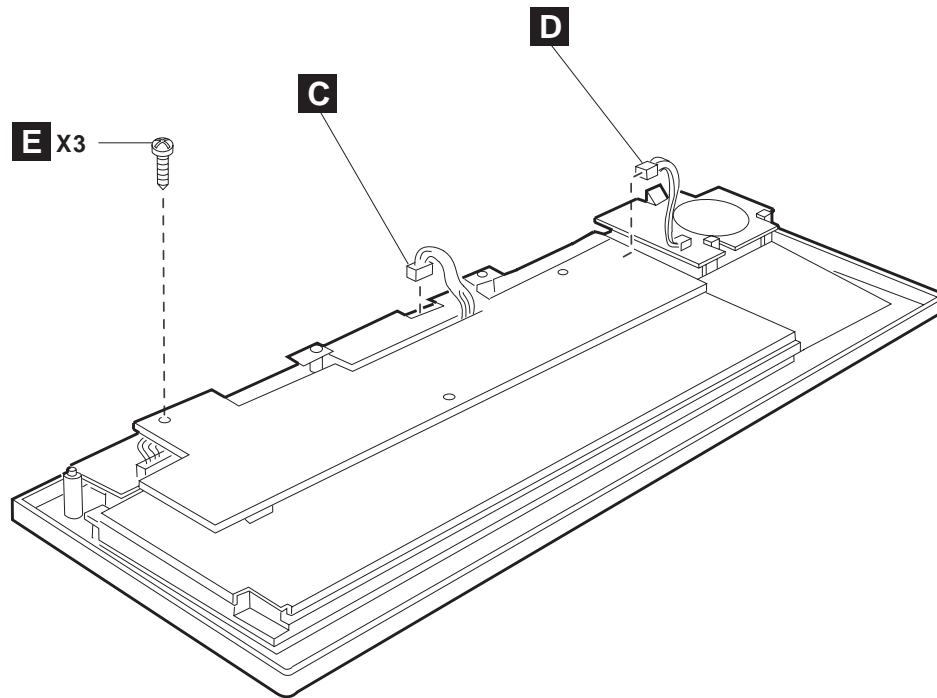

Figure 54. USB keyboard-V components – part 2

3. Disconnect the cable to the speaker assembly at the logic board end (**D**). Do not disconnect the cable from the speaker assembly.
4. Remove the three screws (**E**).
5. Lift the logic board, and turn it over (see Figure 55 on page 56).

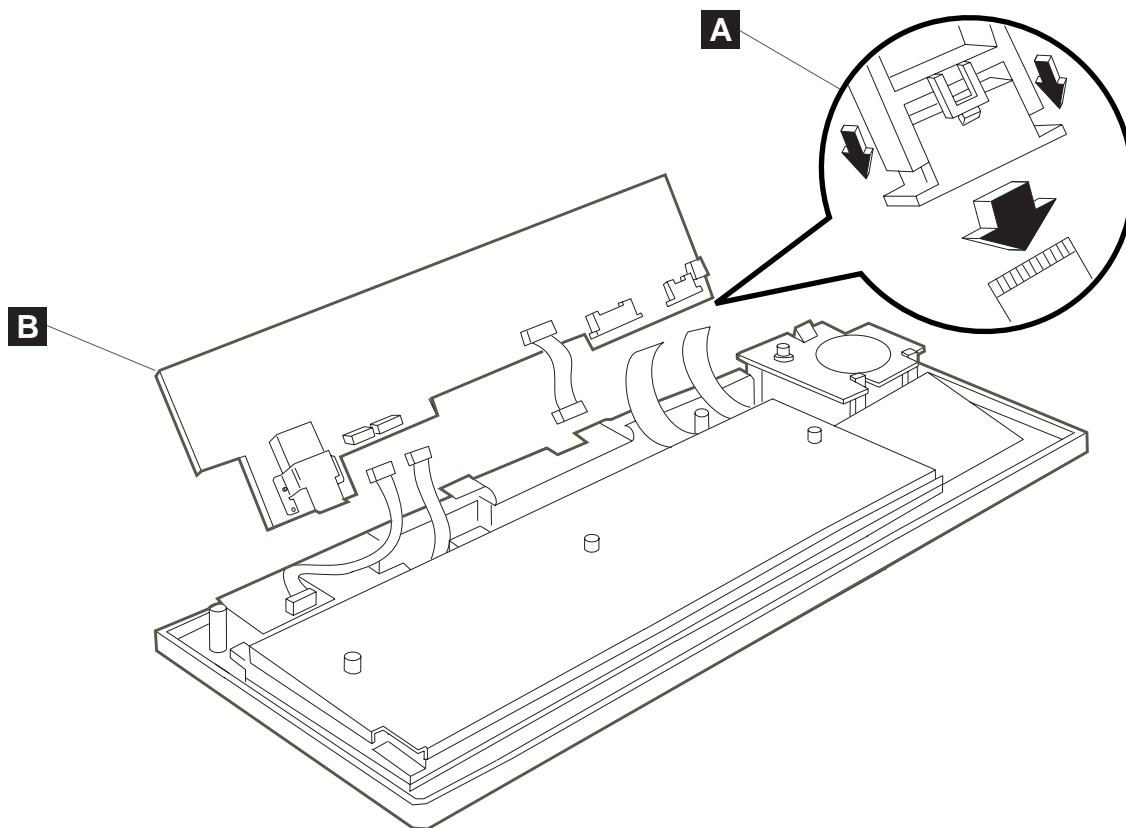

Figure 55. USB keyboard-V components – part 3

6. Disconnect the membrane sheet JP6 and JP7 by releasing the lock of the connector (**A** .)

Note: When replacing the logic board, be careful not to damage the membrane sheet. Do not forget to lock the connectors after inserting the membrane sheet.

7. Disconnect the cable to the LED card at the logic board end (JP4). See **B** .
8. Disconnect the cable to the mode key lock switch at the logic board end (JP3).
9. Replace the logic board.

To reassemble the unit, reverse this procedure.

Removing and replacing the magnetic stripe reader

To remove the MSR:

1. Use the procedure in “Opening the cover” on page 54 to remove the bottom cover assembly.
2. Disconnect the cable to the magnetic stripe reader unit at the magnetic stripe reader unit end (see **C** in Figure 54 on page 55).
3. Remove the two screws (**C** in Figure 56 on page 57).

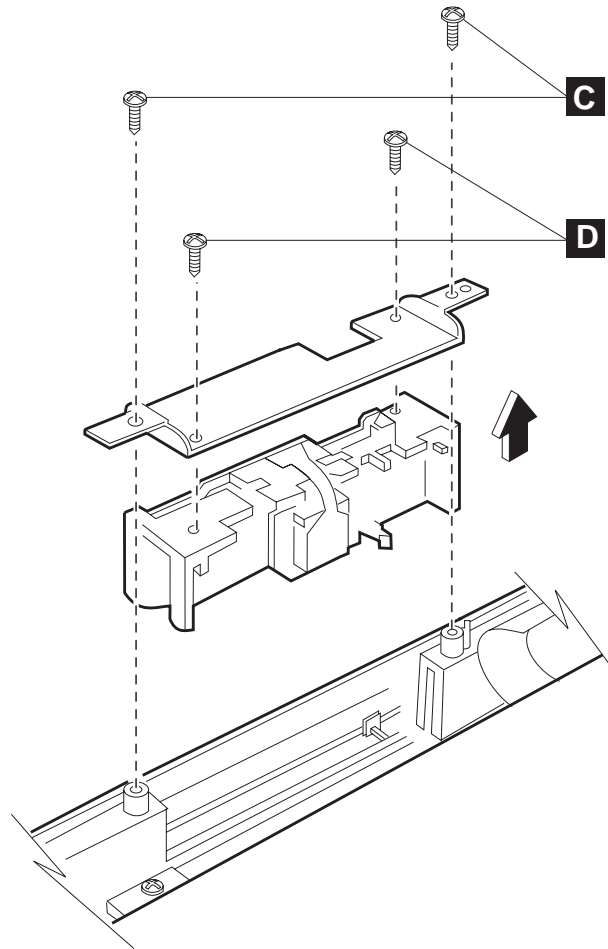

Figure 56. USB keyboard-V components – part 4

4. Remove two additional screws (**D**).
5. Remove the old magnetic stripe reader unit.
6. Install the new magnetic stripe reader unit.

Note: Be careful to correctly orient the magnetic stripe reader unit (see Figure 56).

To reassemble the unit, reverse this procedure.

Removing and replacing the speaker assembly

To remove the speaker assembly:

1. Use the procedure in “Opening the cover” on page 54 to remove the bottom cover assembly.
2. Disconnect the cable from the speaker assembly on the logic board (JP5). See **D** in Figure 54 on page 55.
3. Press the three tabs to unlatch the speaker card.

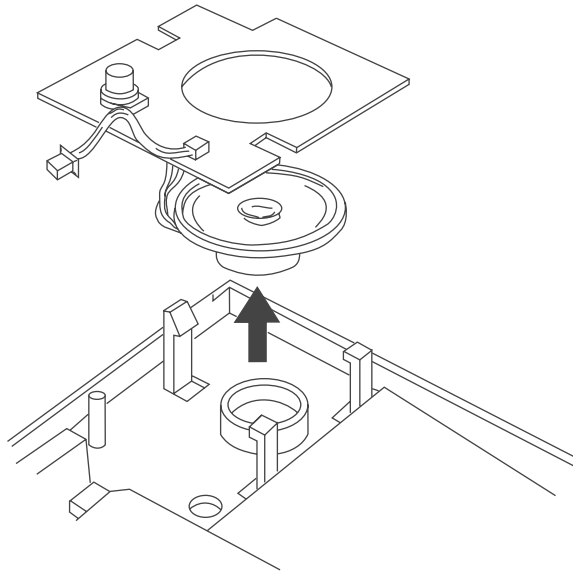

Figure 57. USB keyboard-V components – part 5

4. Remove the old speaker assembly.
5. Install the new speaker assembly.

To reassemble the unit, reverse this procedure.

Removing and replacing the keyboard matrix unit

To remove the keyboard matrix unit:

1. Remove the bottom cover assembly and the logic board as instructed in “Opening the cover” on page 54 and in “Removing and replacing the logic board” on page 54.
2. Remove the three screws as shown in Figure 58 on page 59.

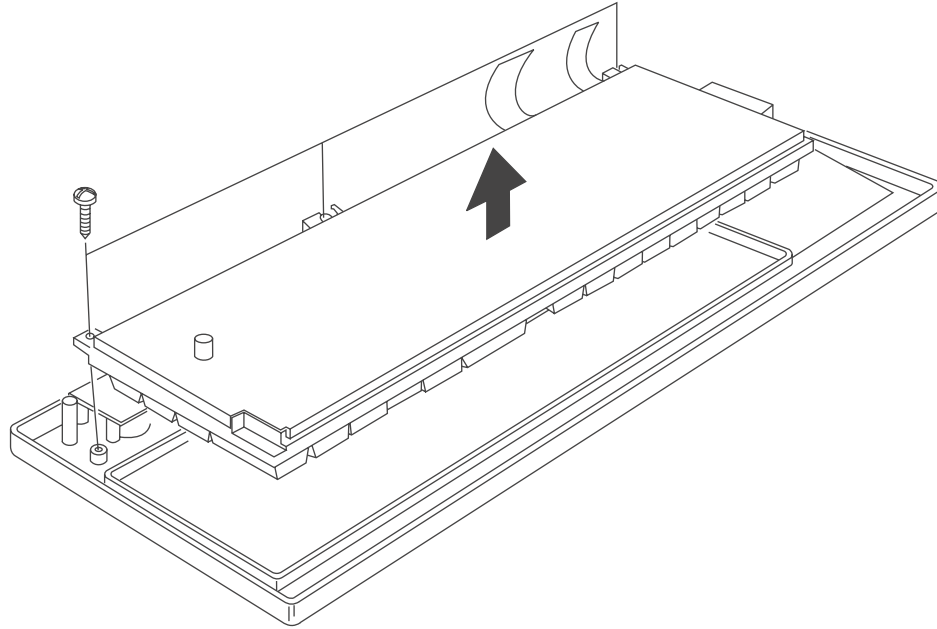

Figure 58. USB keyboard-V components – part 6

3. Remove the old keyboard matrix unit.
4. Install the new keyboard matrix unit.

To reassemble the unit, reverse this procedure.

Removing and replacing the top cover assembly

To remove the top cover assembly:

1. Remove the bottom cover assembly, the logic board, and the key matrix unit using the procedures given in “Opening the cover” on page 54, “Removing and replacing the logic board” on page 54, and “Removing and replacing the keyboard matrix unit” on page 58.

CAUTION:

The mode key lock assembly and the LED assembly are not field-replacable units (FRUs). Do not remove these parts from the top cover assembly.

2. Remove the old top cover assembly.
3. Install the new top cover assembly.

To reassemble the unit, reverse this procedure.

Removing and replacing USB PLU keyboard/display components

This section provides information for repairing the USB PLU keyboard/display. The display unit can not be repaired. You must replace the entire display.

Opening the cover

To open the cover:

1. Remove the eight screws (**A** in Figure 59 on page 60).

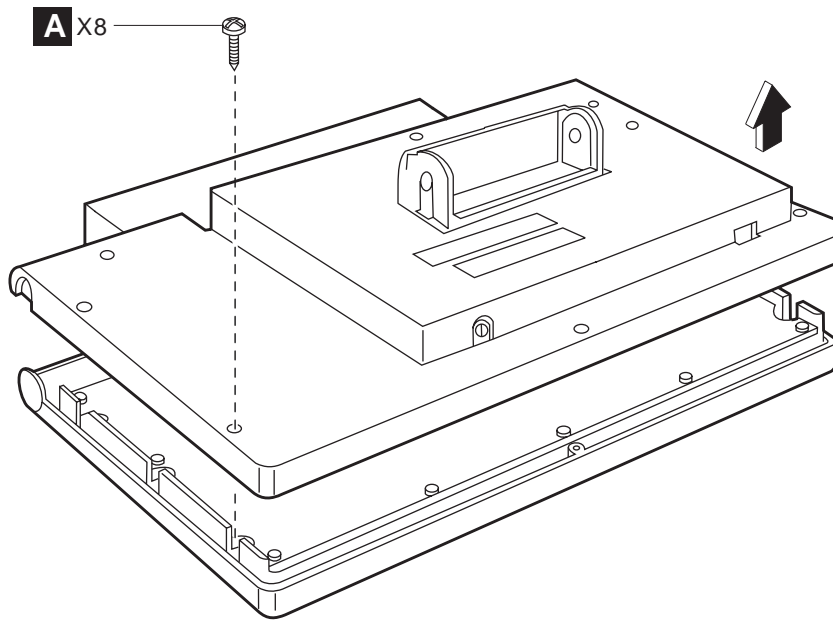

Figure 59. Removing the cover of the USB PLU keyboard/display

2. Lift up the bottom cover assembly.

Removing and replacing the VFD assembly

To remove the VFD assembly:

1. Open the cover as described in the procedure “Opening the cover” on page 59.
2. Lift up the bottom cover assembly.
3. Disconnect the connector to the VFD assembly at the end to the logic board (**B** in Figure 60 on page 61)

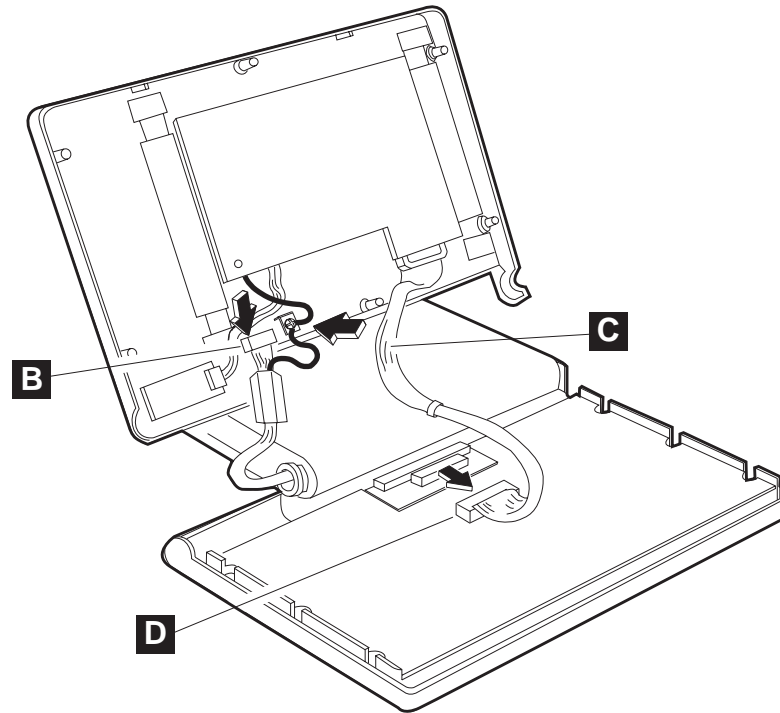

Figure 60. Removing the screws

4. Release the screw (**C**), then disconnect the two cables and one tooth washer.
5. Remove the old VFD assembly.
6. Install the new VFD assembly.

CAUTION:

The VFD assembly contains no FRUs inside. Do not open the case of the VFD assembly.

To reassemble the unit, reverse this procedure.

Removing and replacing the keyboard matrix unit

To remove the keyboard matrix unit:

1. Open the cover by the procedure provided in “Opening the cover” on page 59.
2. Lift the bottom cover assembly
3. Disconnect the cable from the keyboard matrix unit (**D** in Figure 60).
4. Remove the two screws (**A** in Figure 61 on page 62).

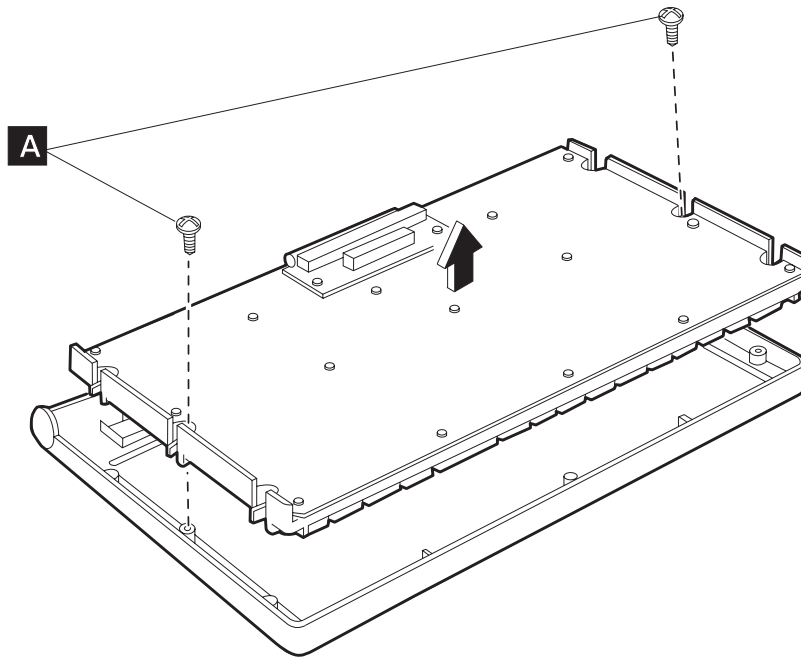

Figure 61. Removing the screws

5. Remove the old keyboard matrix unit.
6. Install the new keyboard matrix unit.

To reassemble the unit, reverse this procedure.

Removing and replacing the logic board

To remove the logic board:

1. Open the cover as described in “Opening the cover” on page 59.
2. Lift up the bottom cover assembly as shown in Figure 62 on page 63

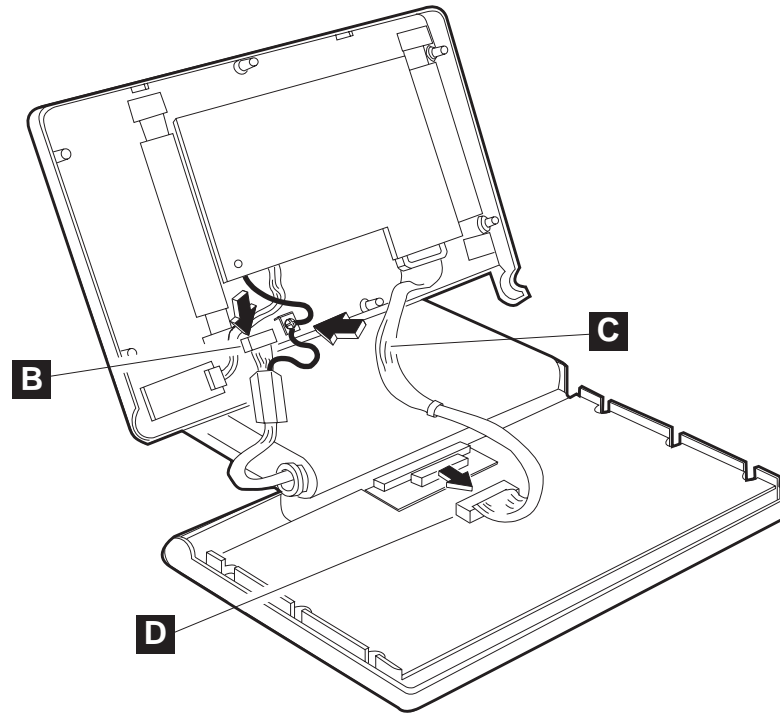

Figure 62. Disconnecting the connector, screws, and cables

3. Disconnect the connector to the VFD assembly at the end of the logic board (**B**).
4. Release the screw (area **C**), then disconnect two cables and one tooth washer.
5. Disconnect the cable from the matrix unit (area **D**).
6. Remove the four screws (**A** in Figure 63).

Note: Two of these four screws have washers.

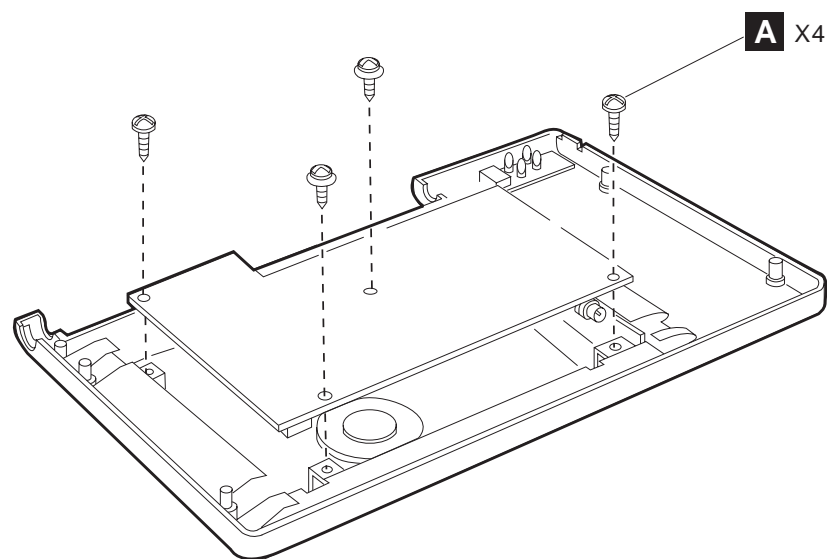

Figure 63. Removing the screws

- Lift up the logic board as shown in Figure 64.

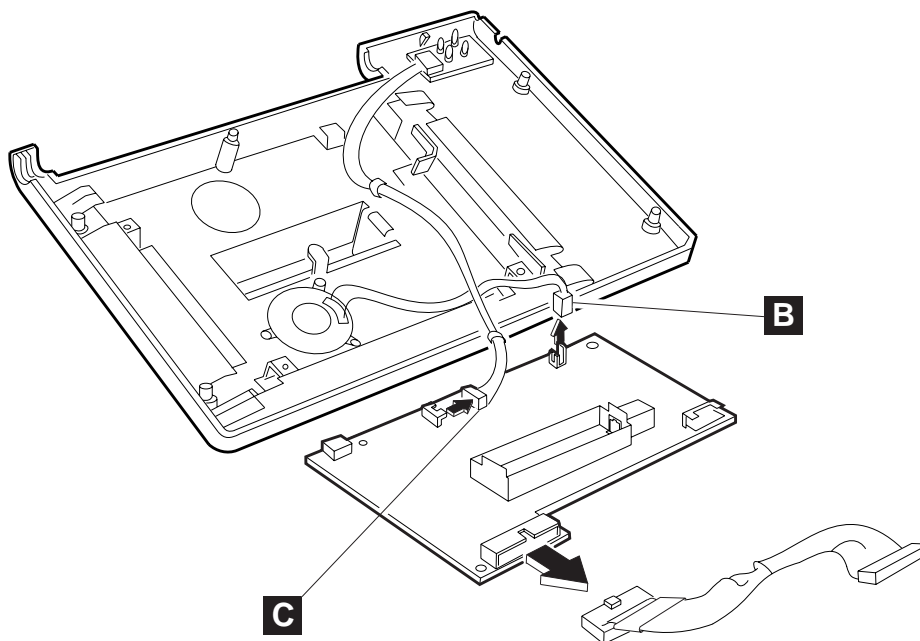

Figure 64. Disconnecting the connector to the LED assembly

- Disconnect the connector to the LED assembly at the end to the logic board (**B** and **C** in Figure 64).
- Remove the old logic board.
- Install the new logic board.

To reassemble the unit, reverse this procedure.

Removing and replacing the bottom cover assembly

To remove the bottom cover assembly:

- Open the cover as described in the procedure “Opening the cover” on page 59.
- Remove the logic board as described in the procedure “Removing and replacing the logic board” on page 62.

CAUTION:

The speaker and the LED assembly attached to the bottom cover are not FRUs. Do not remove those parts from the bottom cover assembly.

- Remove the old bottom cover assembly.
- Install the new bottom cover assembly.
- Write the serial number (S/N) on the blank S/N label on the new bottom cover assembly.

To reassemble the unit, reverse this procedure.

Removing and replacing the top cover assembly

To remove the top cover assembly:

- Open the cover as described in the procedure “Opening the cover” on page 59.
- Remove the keyboard matrix unit as described in the procedure “Removing and replacing the keyboard matrix unit” on page 58.

3. Remove the old top cover assembly.
4. Install the new top cover assembly.

To reassemble the unit, reverse this procedure.

USB PLU extension box

The USB PLU extension box can not be repaired. You must replace the entire unit when necessary. Table 6 and Table 7 will assist you in isolating problems.

Table 6. Symptom explanation and cause

Symptom explanation	Conditions that might cause this symptom
The logic LED on the system unit is on, but both the ac power LED (green) and the dc power LED (yellow) are off.	The symptom might be caused by incomplete cable connections. Disconnect all signal cables and the ac power cables from the USB PLU extension box. Then, reconnect only the ac power cord to the USB PLU extension box. Follow the steps in Table 7.

Table 7. Problem isolation steps

Step 1: Is the ac power (green) LED on?	No	<ul style="list-style-type: none"> • Make sure that the ac power cord is connected to a good ac source. • Replace the USB PLU extension box or the ac power cable.
	Yes	Connect the signal cable to the system unit and the USB PLU extension box when the logic LED on the system unit is on. Go to Step 2.
Step 2. Is the dc power (yellow) LED on, while the ac power (green) is on?	No	<ul style="list-style-type: none"> • Make sure that the dc power (yellow) LED does not turn on when it is connected to the other system unit. • Replace the USB PLU extension box or its signal cables.
	Yes	Connect the I/O devices one by one. Go to Step 3.
Step 3. Is the dc power (yellow) LED still on?	No	<ul style="list-style-type: none"> • Replace the I/O device that caused the dc power (yellow) LED to turn off. • Replace the USB PLU Extension Box.
	Yes	Go to Step 4.
Step 4. The enumeration of all I/O devices connected to the USB PLU extension box is complete.	No	<ul style="list-style-type: none"> • Replace the I/O device that failed its enumeration. • Make sure that all USB I/O devices are connected to the system unit.
	Yes	Quit the problem isolation.

Chapter 5. Parts catalog

How to use this parts catalog	67
Assembly 1: Cash drawer, wide	70
Assembly 2: Cash drawer (4693/4694, 4683/4684)	72
Assembly 3: Cash drawer, compact	74
Assembly 4: Video displays	76
Assembly 5: 40-character displays	78
Assembly 6: USB and RS-485 character/graphics display	80
Assembly 7: PS/2 ANPOS keyboard with integrated pointing device	82
Assembly 8: CANPOS keyboard with integrated pointing device	86
Assembly 9: Keyboard, USB and RS-485, 50-key, with or without MSR	90
Assembly 10: Keyboard, USB and RS-485, 50-key, with MSR and LCD	92
Assembly 11: Keyboard, USB, 50-key, with JUCC (Japan)	94
Assembly 12: Keyboard, USB and Modifiable Layout RS-485, 133-key, with MSR	96
Assembly 13: Keyboard, USB and RS-485, ANPOS, with MSR	98
Assembly 14: Keyboard, USB and RS-485, ANKPOS, with MSR (Japan)	102
Assembly 15: Keyboard-V, USB (Japan)	104
Assembly 16: USB PLU keyboard/display (Japan, Korea)	106
Assembly 17: USB PLU extension box (Japan, Korea)	108
Assembly 18: Fillers for character/graphics display and printer (SurePOS 700 Japan and Korea)	110
Assembly 19: Fillers and table-top slanted I/O tray (SurePOS 700)	112
Assembly 20: Countertop non-keyboard integration tray and filler panels (SurePOS 500)	114
Assembly 21: Cash drawer non-keyboard integration tray and filler panels (SurePOS 500)	116
Assembly 22: Countertop and cash drawer keyboard integration tray and filler panels (SurePOS 500)	118
Assembly 23: Other FRUs that are not shown	120

This chapter lists the part numbers for cash drawers, displays, keyboards, and their associated cables and mounts. This chapter also includes additional options, such as filler panels and I/O trays, that you can use with Store Systems.

Note: The part numbers in this catalog can be used to repair products installed before or after July 1, 2006.

How to use this parts catalog

This parts catalog contains reference drawings and a corresponding index for field-replaceable parts. The parts index provides the part number, the quantity that is required (units), and a description of the part.

Listed below is additional information about the parts assembly index.

Similar assemblies

If two assemblies contain a majority of identical parts, they are broken down on the same list. Common parts are shown by one index number. Parts that are specific to one or the other of the assemblies are listed separately and identified by their descriptions.

- AR (As Required)** Specified in the Units column. Indicates that the quantity is not the same for all machines.
- NP (Not Procurable)** Specified in the Units column. Indicates that the part is non-procurable and that the individual parts or the next higher assembly should be ordered.
- NR (Not Recommended)** Specified in the Units column. Indicates that the part is procurable, but not recommended for field replacement, and that the next higher assembly should be ordered.
- R (Restricted)** Specified in the Units column. Indicates that the part has a restricted availability.

The indenture is marked by a series of dots that are located before the parts description. The indenture indicates the relationship of a part to the next higher assembly, in the following manner:

- | Indenture | Relationship of Parts |
|-------------------|--|
| No dot | Main assembly |
| One dot | • Detail parts of a main assembly |
| One dot | • Subassembly of the main assembly |
| Two dots | •• Detail part of a one-dot subassembly |
| Two dots | •• Subassembly of a one-dot subassembly |
| Three dots | ••• Detail part of a two-dot subassembly |

Assembly n: Example assembly

Asm-Index	Part Number	Units	Description
<i>n-</i>	2512667	1	Cover assembly, rear, red
-	2512668	1	Cover assembly, rear, yellow For next-higher assembly, see assembly 1-2
-1	5373637	1	• Seal, top
-2	5356429	2	• Clip, retaining
-3	2513013	3	• Liner, cover
-4	5373727	1	• Seal, left side
-5	1847630	R	• Finger stock assembly
-6	1847602	NR	•• Channel, finger stock
-7	1847604	NR	•• Finger stock, 2.0 cm long
-8	5373639	AR	• Seal, bottom

last update: March 22, 2007

Assembly 1: Cash drawer, wide

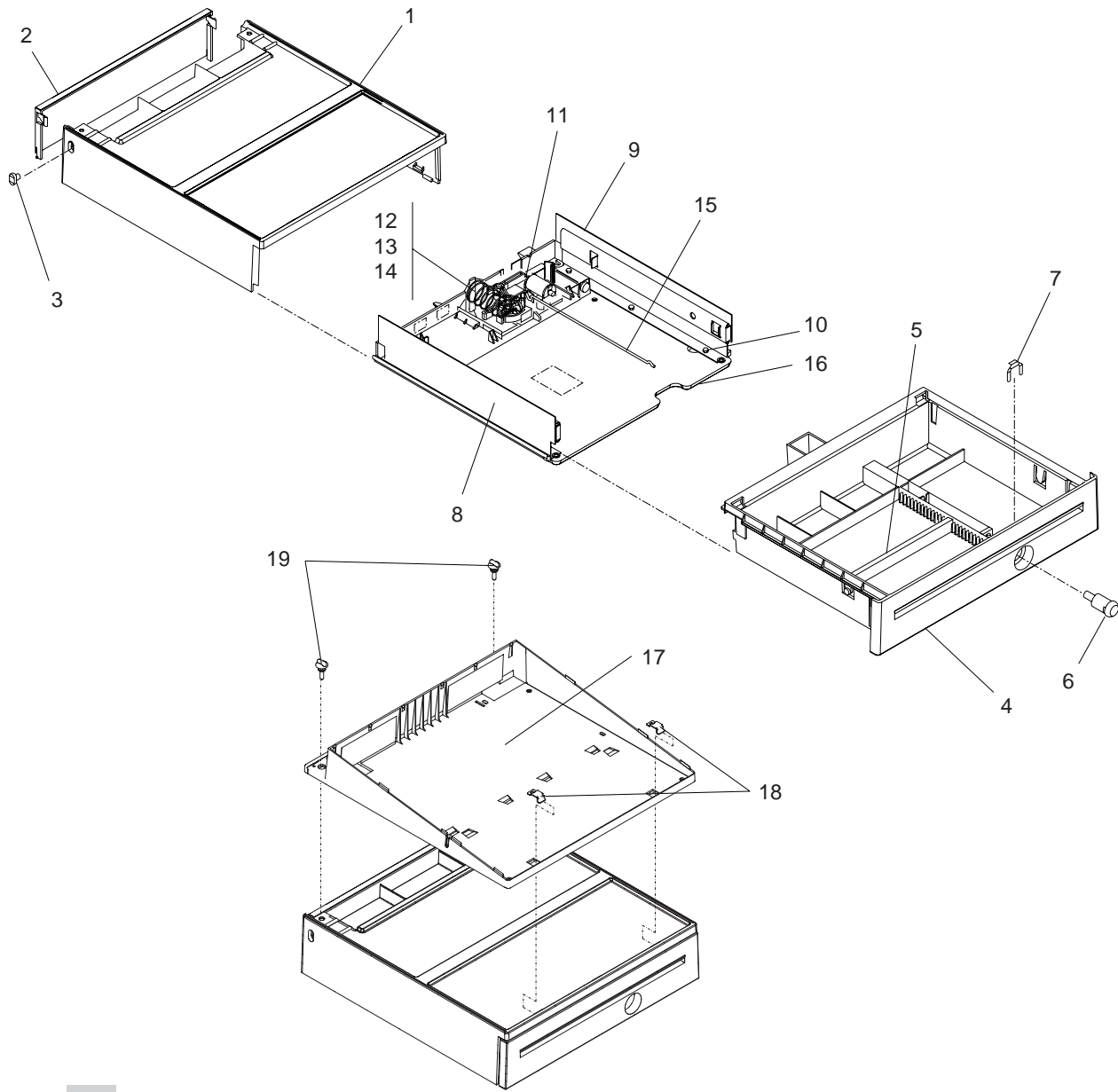

Asm-Index	Part Number	Units	Description
1-		NP	Cash drawer assembly, wide
-1	41J9271	1	• Cover, top, storm (light) gray
-1	41J7272	1	• Cover, top, iron (dark) gray
-1	41J9251	1	• Cover, top, litho gray
-2	55H6864	1	• Panel, rear, storm (light) gray
-2	20P0279	1	• Panel, rear, iron (dark) gray
-2	93F1901	1	• Panel, rear, litho gray
-3	13H8313	2	• Button, storm (light) gray
-3	20P0276	2	• Button, iron (dark) gray
-3	93F1902	2	• Button, litho gray
-4	55H6865	1	• Drawer, storm (light) gray
-4	20P0278	1	• Drawer, iron (dark) gray
-4	93F1908	1	• Drawer, litho gray
-5	93F1897	1	• Stop, document
-6	41J9487	1	• Lock
-			• See Standard Lock Inserts and Premium Lock Inserts in “Assembly 23: Other FRUs that are not shown” on page 120 for additional lock options.
-	93F1912	1	• Lock blank, litho gray only (not shown)
-7	41J9282	1	• Lock, clip
-8	41J9275	1	• Slide, left
-9	41J9276	1	• Slide, right
-10	1621594	6	• Screw
-11	41J9307	1	• Latch asm (without card)
-12	93F1915	1	• Propulsion spring
-13	41J7271	1	• Motor card asm, 24 V
-13	41J7232	1	• Motor card asm, 38 V
-14	93F1913	1	• Cam, pawl, and spring kit
-15	41J9274	1	• Actuator rod
-16	93F1904	1	• Base, raven black
-17	30L6223	1	Slanted I/O tray, cash drawer, storm (light) gray
-17	34L4286	1	Slanted I/O tray, cash drawer, iron (dark) gray
-18	30L6224	2	Mounting tab, cash drawer integration
-19	30L6240	2	Screw, molded, storm (light) gray
-19	10N1346	2	Screw, molded, iron (dark) gray
-	42P8025		Till, Euro (not illustrated)
-	4783879	AR	Till, fixed (not illustrated)
-	4783880	AR	Till, adjustable (not illustrated)
-	6316718	AR	Till cover, locking (not illustrated)
-	4783875	AR	Mount (not illustrated)
-	4783876	AR	Bill holder (not illustrated)
-	4783877	AR	Coin divider (not illustrated)
-	4783878	AR	Bill divider (not illustrated)
-	13H9612	AR	Under-counter mounting bracket (not illustrated)
-	42H3791		Drawer/slide repair kit

Assembly 2: Cash drawer (4693/4694, 4683/4684)

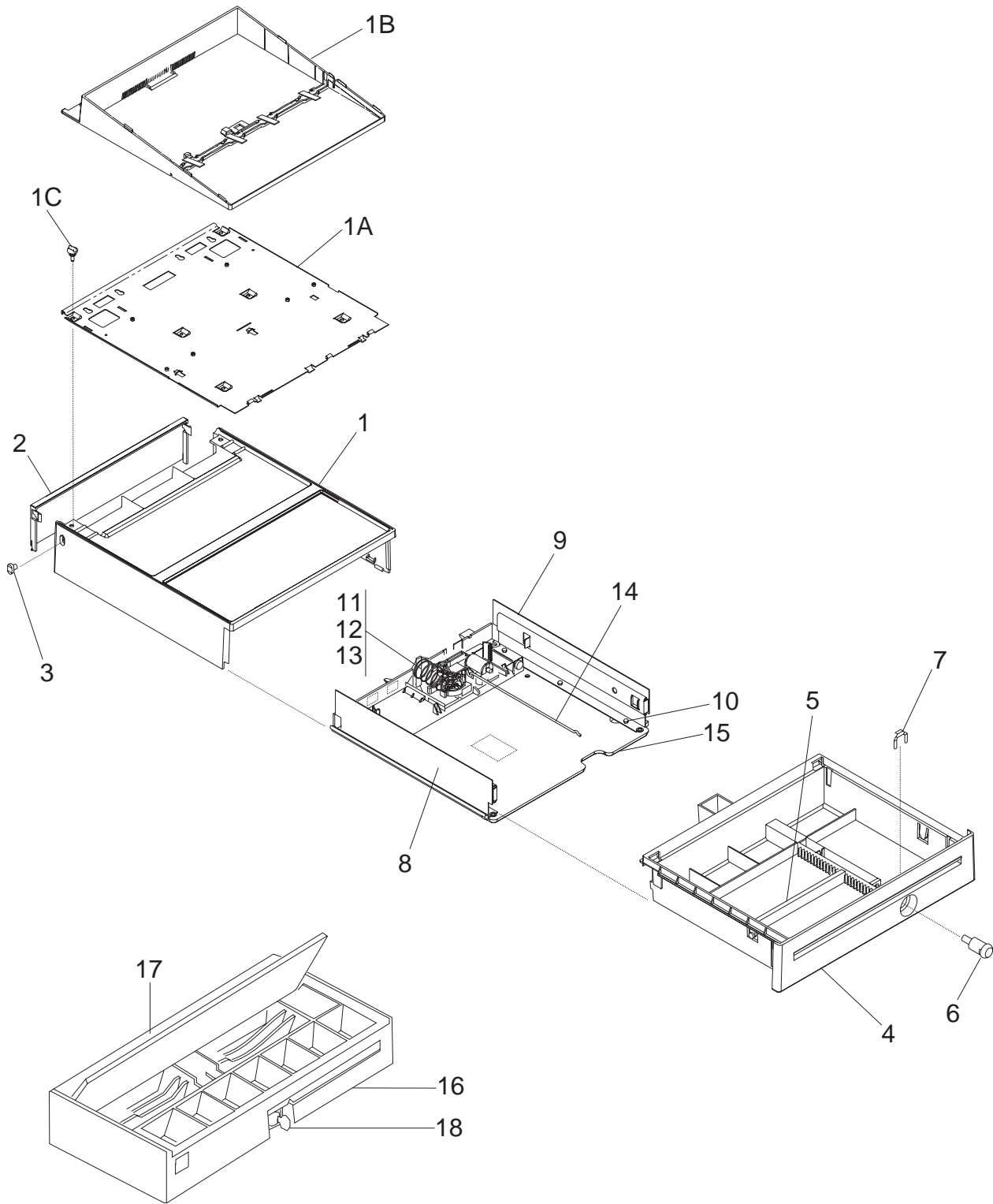

Asm-Index	Part Number	Units	Description
2-		NP	Cash drawer assembly (4693/4694)
-1	41J9251	1	• Cover, top, litho gray
-1A	93F1780	1	• Plate, I/O mounting, flat
-1B	93F1795	1	• Fence asm, Integrated I/O (requires 93F1780, index 1A)
-1C	93F1779	2	• Screw, mounting
-2	93F1901	1	• Panel, rear
-3	93F1902	2	• Button
-4	93F1908	1	• Drawer
-5	93F1897	1	• Stop, document
-6	41J9487	1	• Lock
-			• See Standard Lock Inserts and Premium Lock Inserts in “Assembly 23: Other FRUs that are not shown” on page 120 for additional lock options.
-7	93F1910	1	• Lock, clip
-8	41J9275	1	• Slide, left
-9	41J9276	1	• Slide, right
-10	1621594	6	• Screw
-11	93F1915	1	• Propulsion spring
-12	41J7271	1	• Motor card asm, 24 V
-12	41J7232	1	• Motor card asm, 38V
-13	93F1913	1	• Cam, pawl, and spring kit
-14	41J9274	1	• Actuator rod
-15	93F1904	1	• Base, raven black
-	4783879	AR	Till, fixed (not illustrated)
-	4783880	AR	Till, adjustable (not illustrated)
-	6316718	AR	Till cover, locking (not illustrated)
-	4783875	AR	Flipper mount (not illustrated)
-	4783876	AR	Bill holder (not illustrated)
-	4783877	AR	Coin divider (not illustrated)
-	4783878	AR	Bill divider (not illustrated)
-	76X0200	NR	Cash drawer asm, tilt top, light gray, single-byte (4683/4684)
-	74F6307	NR	Cash drawer asm, tilt top, light gray, double-byte (4683/4684)
-	41J7693	NR	Cash drawer asm, tilt top, dark gray, single-byte (4693/4694)
-	41J7694	NR	Cash drawer asm, tilt top, dark gray, double-byte (4693/4694)
-16	25H4178	NR	• Housing, light gray (4683/4684)
-16	25H4179	NR	• Housing, dark gray (4693/4694)
-17	41J9488	1	• Release mechanism kit, single-byte
-17	41J9489	1	• Release mechanism kit, double-byte
-18	25H4183	1	• Keylock asm

Assembly 3: Cash drawer, compact

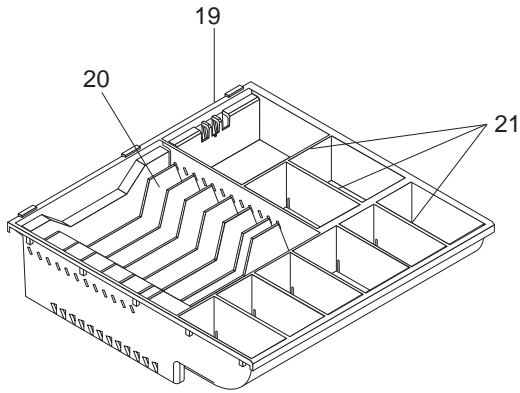
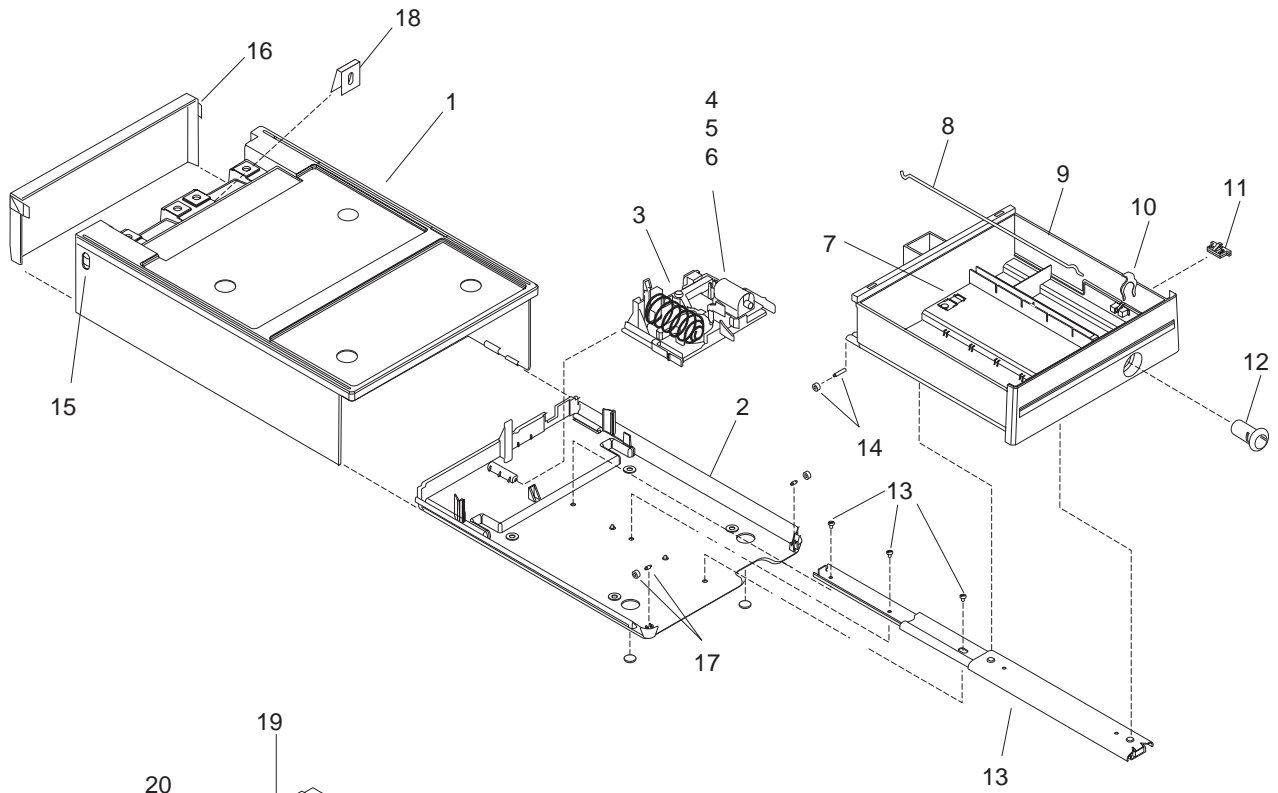

Vertical Till

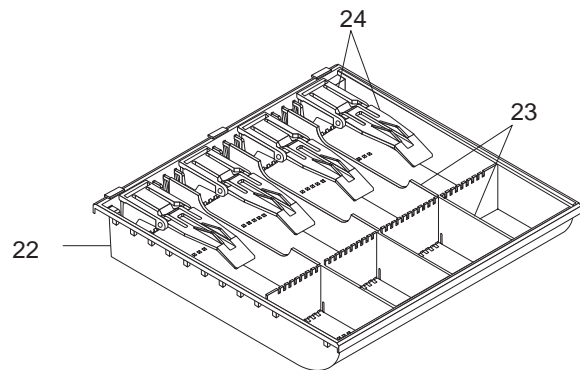

Horizontal Till

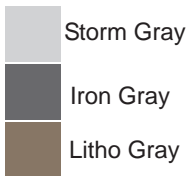

Asm-Index	Part Number	Units	Description
3-		NP	Cash drawer, compact
-1	41J9293	1	• Cover, top, storm (light) gray
-1	41J9294	1	• Cover, top, iron (dark) gray
-1	41J9292	1	• Cover, top, litho gray (and 4694 Models 001, 004, and 024/4695) Includes index 15
-2	10H3315	1	• Base, cash drawer, raven black
-3	41J9307	1	• Latch asm (without card)
-3	93F1903	1	• Latch and sensor asm (4694 Models 001, 004, and 024/4695)
-4	93F1915	1	• • Propulsion spring
-5	41J7271	1	• • Motor card asm, 24 V
-5	41J7232	1	• • Motor card asm, 38 V
-6	93F1913	1	• • Cam, pawl, and spring kit
-7	10H3375	2	• Slide latch, cash drawer
-8	41J9274	1	• Actuator rod
-9	13H8311	1	• Drawer asm, storm (light) gray
-9	15K2010	1	• Drawer asm, iron (dark) gray
-9	10H3317	1	• Drawer asm, litho gray (and 4694 Models 001, 004, and 024/4695) Drawer assemblies include index 7 and 14.
-10	41J9282	1	• Lock, clip
-11	10H3355	1	• Coin-roll opener asm
-12	41J9487	1	• Lock
-			• See Standard Lock Inserts and Premium Lock Inserts in “Assembly 23: Other FRUs that are not shown” on page 120 for additional lock options.
-13	41J9299	1	• Slide asm (includes 3 screws)
-14	10H3373	1	• Roller and shaft kit (2 pairs)
-15	13H8313	2	• Button, modesty panel, storm (light) gray
-15	20P0276	2	• Button, modesty panel, iron (dark) gray
-15	93F1902	1	• Button, modesty panel, litho gray (and 4694 Models 001, 004, and 024/4695)
-16	13H8312	1	• Modesty panel, storm (light) gray
-16	20P0329	1	• Modesty panel, iron (dark) gray
-16	10H3318	1	• Modesty panel, litho gray (and 4694 Models 001, 004, and 024/4695)
-17	10H3374	1	• Bearing and shaft kit (2 pairs)
-18	41J9672	1	• Security clip
-	13H9612		• Under-counter mounting bracket FRU (not illustrated)
			Vertical till
-19	10H3331	AR	Till asm, vertical
-20	10H3379	AR	• Bill divider kit Includes 7 dividers.
-21	10H3380	AR	• Coin divider kit Includes 5 dividers and 1 storage partition.
-	10H3341	AR	• Locking till cover (not illustrated)
-	10H3340	AR	• Locking till cover (not illustrated) (4694 Models 001, 004, and 024/4695)
			Horizontal till
-22	10H3371	AR	Till asm, horizontal
-23	10H3381	AR	• Divider kit (not illustrated) Includes 3 coin dividers, 3 bill dividers, and 1 document stop.
-24	10H3319	AR	• Bill holder kit Includes holder and mount.
-	10H3341	AR	Locking till cover (not illustrated)
-	10H3340	AR	Locking till cover (not illustrated) (4694 Models 001, 004, and 024/4695)

Assembly 4: Video displays

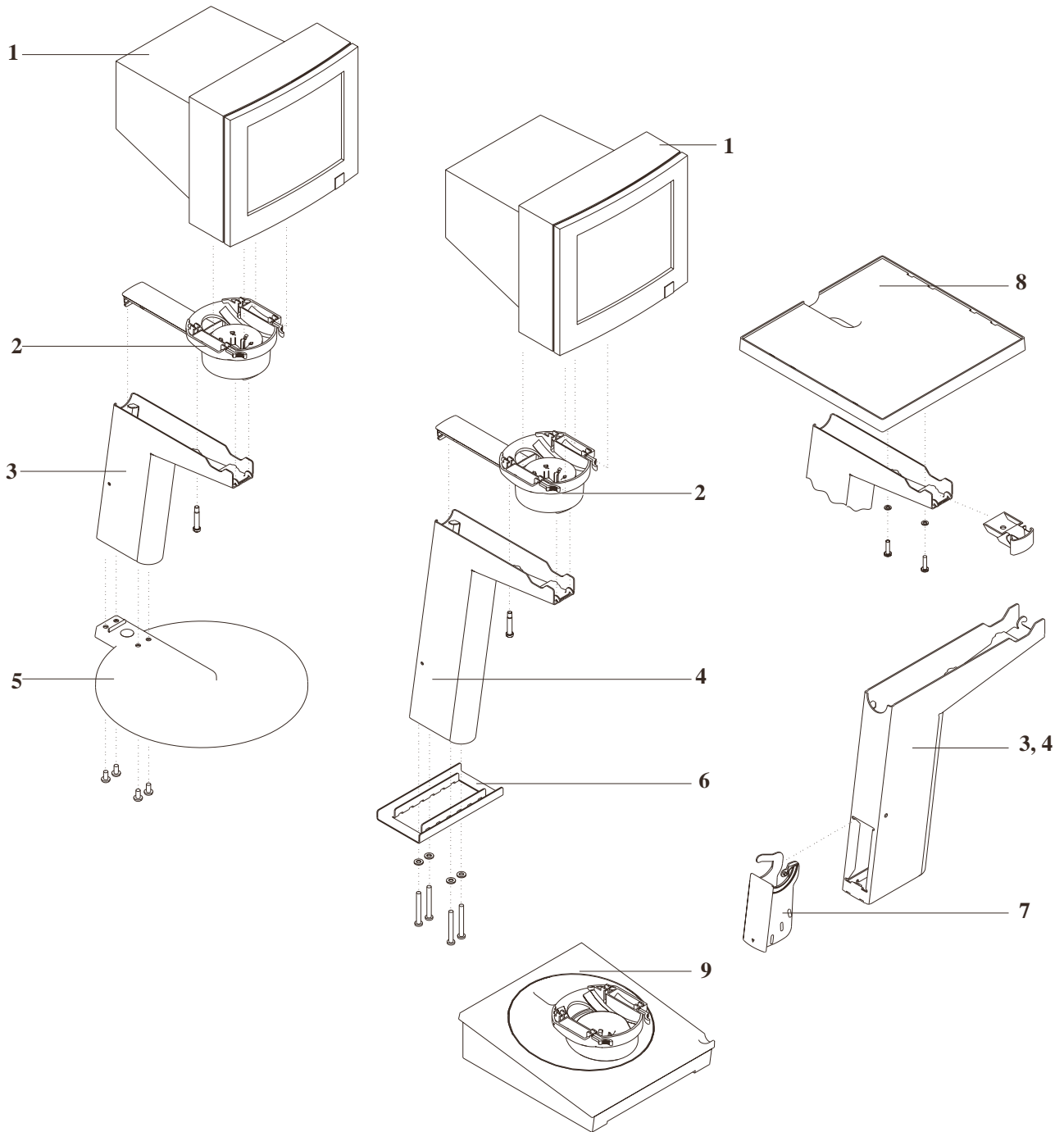

Asm- Index	Part Number	Units	Description
4-1	10J0584	1	Display, 9-in. monochrome, 1.0 m cables
-1	10J0585	1	Display, 9-in. monochrome, 2.6 m cables
-2	30L6193	1	Mount, mono swivel
-3	30L6190	1	Mount, short post
-4	30L6189	1	Mount, tall postl
-5	30L6191	1	Plate, mounting
-6	30L6257	1	Plate, stiffener
-7	30L6214	1	Cable cover
-8	30L6194	1	Table, display
-	30L6304	AR	Miscellaneous fasteners and mounting feet (not illustrated)
-9	30L6188	1	Mount, monochrome display, wedge

Assembly 5: 40-character displays

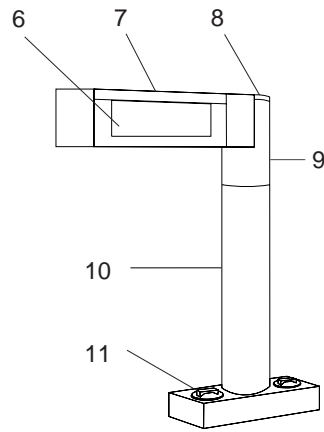
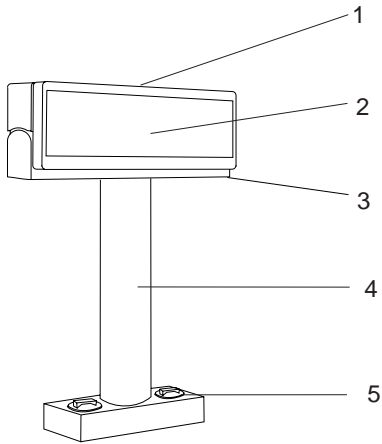

Asm-Index	Part Number	Units	Description
5-			40-character VFD
-1	41J6865	1	Asm, single-sided, USB, storm (light) gray
-1	41J6683	1	Asm, single-sided, USB, iron (dark) gray
-1	41D0161	1	Asm, single-sided, RS-232, iron (dark) gray
-1	41K6848	1	Asm, single-sided, RS-485, litho gray
-1	41J7207	1	Asm, single-sided, RS-485, iron (dark) gray
-1	41J7207	1	Asm, two-sided, USB, storm (light) gray
-1	41K6876	1	Asm, two-sided, RS-485, litho gray
-1	41J6648	1	Asm, two-sided, RS-485, storm (light) gray
-1	41J8009	1	Asm, AP, RS-485
-2	13H4850	1	Lens kit, contains one (1) lens and instructions
-3	25L5486	1	Yoke asm, single-sided display, storm (light) gray
-3	25L5487	1	Yoke asm, two-sided display, storm (light) gray
-3	20P0338	1	Yoke asm, single-sided display, iron (dark) gray
-4	25L5488	1	Post, storm (light) gray
-4	20P0334	1	Post, iron (dark) gray
-5	25L5505	2	Thumbscrew, short, storm (light) gray
-5	20P0337	2	Thumbscrew, short, iron (dark) gray
-			Note: Long thumbscrews* are used on SurePOS 700 Models 721, 741, and 781 when an integration tray is not installed.
-5	14J0747	2	Thumbscrew, long, iron (dark) gray*
-5	14J0797	2	Thumbscrew, long, storm (light) gray*
-5	14J0802	2	Thumbscrew, long, litho gray*
-	25L5498	1	Post, extension (not illustrated), storm (light) gray
-	20P0360	1	Post extension (not illustrated), iron (dark) gray
			40-character LCD
-6	41J7306	1	USB asm, storm (light) gray
-6	41J7307	1	USB asm, iron (dark) gray
-6	41J7308	1	RS-485 asm, storm (light) gray
-7	25L5519	1	Cover, top, storm (light) gray
-7	10N1327	1	Cover, top, iron (dark) gray
-8	25L5521	1	Cap, post, storm (light) gray
-8	10N1328	1	Cap, post, iron (dark) gray
-9	25L5520	1	Head asm post, storm (light) gray
-9	10N1326	1	Head asm post, iron (dark) gray
-10	25L5488	1	Post, storm (light) gray
-10	20P0334		Post, iron (dark) gray
-11	25L5505	2	Thumbscrew, short, storm (light) gray
-11	20P0337	2	Thumbscrew, short, iron (dark) gray
-			Note: Long thumbscrews* are used on SurePOS 700 Models 721, 741, and 781 when an integration tray is not installed.
-11	14J0747	2	Thumbscrew, long, iron (dark) gray*
-11	14J0797	2	Thumbscrew, long, storm (light) gray*
-11	14J0802	2	Thumbscrew, long, litho gray*
-			
-	25L5498	1	Post, extension (not illustrated), storm (light) gray
-	20P0360	1	Post, extension (not illustrated), iron (dark) gray

Assembly 6: USB and RS-485 character/graphics display

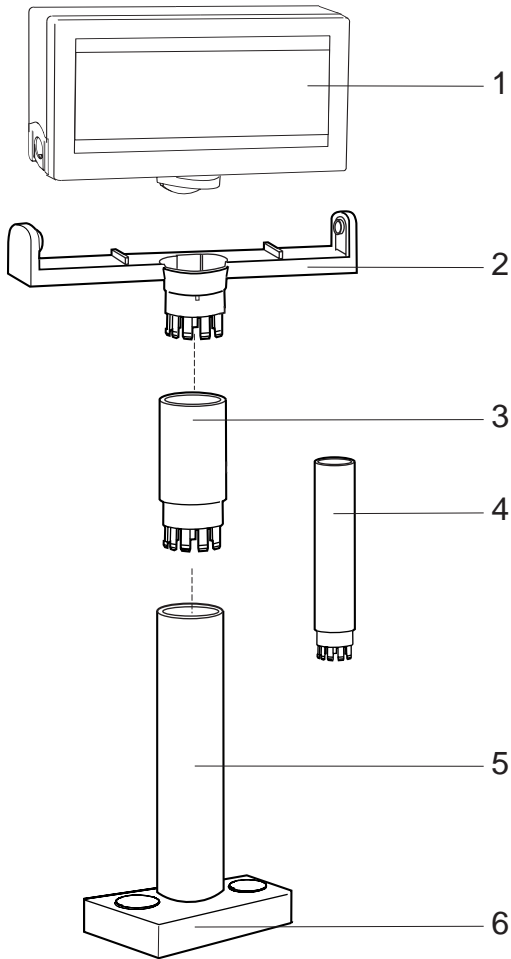

Asm-Index	Part Number	Units	Description
6-1	41J8004	1	VFD unit, USB worldwide, except DBCS
-2	41D0163	1	VFD unit, distributed, customer (APA)
-1	42M5937	1	VFD unit, USB, Japan
-1	44D0271	1	VFD unit, USB, Korea
-1	42M5938	1	VFD unit, USB, People's Republic of China
-1	42M5939	1	VFD unit, USB, Taiwan
-1	41J8005	1	VFD unit, RS-485
-1	41J8006	1	VFD unit, RS-485, tall, Japan
-1	41J8007	1	VFD unit, RS-485, short, Japan
-1	41J8008	1	VFD unit, RS-485, tall, Korea
-1	41J8010	1	VFD unit, RS-485, short, Korea
-6	14J0797	2	Thumbscrew, long*
-	42M5643	1	Cable, display, USB, short
-	41J6835	1	Cable, display, USB, medium
-	42M5641	1	Cable, display, USB, long
-	42M5649	1	Cable, display, RS-485, short (0.8 m)
-	42M5646	1	Cable, display, RS-485, medium (1.8 m)
-	42M5634	1	Cable, display, RS-485, long (3.8 m)
-	42M5647	1	Cable, display, RS-485, 4694, long (3.8 m)

Assembly 7: PS/2 ANPOS keyboard with integrated pointing device

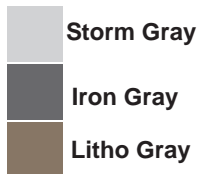
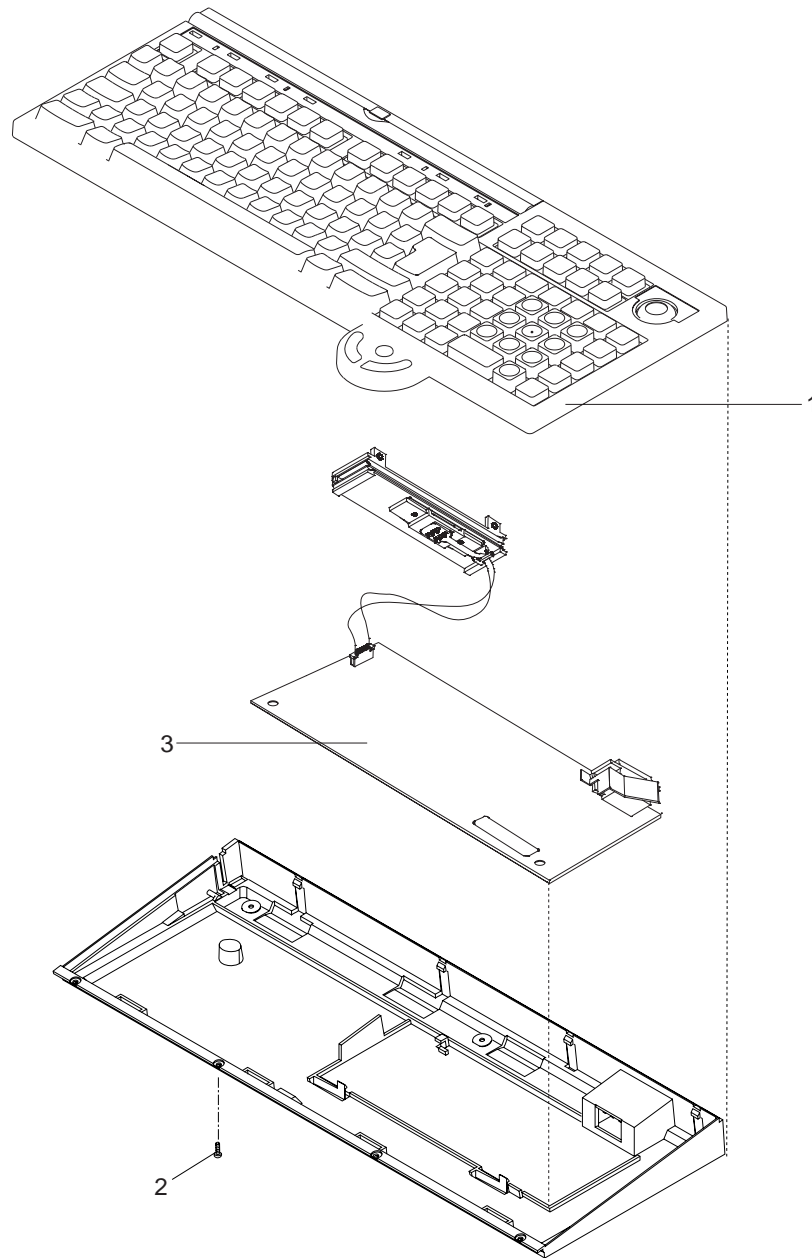

Asm-Index	Part Number	Units	Description
7-			Note: FRUs for the keyboards listed in the note following this parts list are no longer available; the entire keyboard should be replaced.
-1	41K6951	1	PS/2 ANPOS keyboard with integrated pointing device asm, US English, litho gray
-1	41K6945	1	PS/2 ANPOS keyboard with integrated pointing device asm, US English, storm (light) gray
-1	41K6963	1	PS/2 ANPOS keyboard with integrated pointing device asm, US English, iron (dark) gray
-1	41K6953	1	PS/2 ANPOS keyboard with integrated pointing device asm, UK English, litho gray
-1	41K6943	1	PS/2 ANPOS keyboard with integrated pointing device asm, UK English, storm (light) gray
-1	41K6965	1	PS/2 ANPOS keyboard with integrated pointing device asm, UK English, iron (dark) gray
-1	41K6957	1	PS/2 ANPOS keyboard with integrated pointing device asm, Spanish, litho gray
-1	41K6947	1	PS/2 ANPOS keyboard with integrated pointing device asm, Spanish, storm (light) gray
-1	41K6969	1	PS/2 ANPOS keyboard with integrated pointing device asm, Spanish, iron (dark) gray
-1	41K6955	1	PS/2 ANPOS keyboard with integrated pointing device asm, French, litho gray
-1	41K6949	1	PS/2 ANPOS keyboard with integrated pointing device asm, French, storm (light) gray
-1	41K6967	1	PS/2 ANPOS keyboard with integrated pointing device, asm, French, iron (dark) gray
-1	41K6959	1	PS/2 ANPOS keyboard with integrated pointing device, asm, Canadian French, litho gray
-1	41K6961	1	PS/2 ANPOS keyboard with integrated pointing device, asm, Canadian French, iron (dark) gray
-	41J8043	1	Key button asm, top, US English, litho gray keys
-	41J8040	1	Key button asm, top, US English, storm (light) gray keys
-	41J8049	1	Key button asm, top, US English, iron (dark) gray keys
-	41J8044	1	Key button asm, top, UK English, litho gray keys
-	41J8039	1	Key button asm, top, UK English, storm (light) gray keys
-	41J8050	1	Key button asm, top, UK English, iron (dark) gray keys
-	41J8046	1	Key button asm, top, Spanish, litho gray keys
-	41J8041	1	Key button asm, top, Spanish, storm (light) gray keys
-	41J8052	1	Key button asm, top, Spanish, iron (dark) gray keys
-	41J8045	1	Key button asm, top, French, litho gray keys
-	41J8042	1	Key button asm, top, French, storm (light) gray keys
-	41J8051	1	Key button asm, top, French, iron (dark) gray keys
-	41J8047	1	Key button asm, top, Canadian French, storm (light) gray keys
-	41J8048	1	Key button asm, top, Canadian French, iron (dark) gray keys
-2	41J9163	4	Screw, M3 self-tapping
-3	41J9168	1	Card asm, keyboard logic, and MSR
-	90X9640	1	Test card, MSR
-	41J9165	1	Lock asm, NANPOS
-			See Standard Lock Inserts in "Assembly 23: Other FRUs that are not shown" on page 120 for additional lock options.
-	42M5599	1	Straight connector, CANPOS or PS/2 ANPOS, short (0.7 m)
-	41J6860	1	Straight connector, CANPOS or PS/2 ANPOS, medium (1.475 m)
-	42M5597	1	Straight connector, CANPOS or PS/2 ANPOS, long (3.8 m)
-	41J6862	1	Cable, PS/2 ANPOS keyboard with integrated pointing device, pebble gray (1.275 m)
-	41J9171	1	LED asm, 3 lights
-	41J9170	1	LED asm, 4 lights

Asm-Index	Part Number	Units	Description
-	93F1950	1	Lens cap 1 in. 1x1 (25), pearl white
-	93F1951	1	Lens cap 1 in. 1x2 (25), pearl white
-	93F1952	1	Lens cap 1 in. 1x1 Tall (25), pearl white
-	93F1953	1	Lens cap 1 in. 1x2 Tall (25), pearl white
-	30R0037	1	Pointer cap, rubber (10)
-			Note: The redesigned cap (with the textured surface) for the keyboard pointing device (joystick) is a consumable item; the customer is responsible for cap replacement. If you have this style cap, replacement caps can be purchased by calling 1-800-IBM-CALL (1-800-426-2255) in the US and Canada. Customers outside the US and Canada should contact their IBM representative.

Note: FRUs for the keyboards listed in the following table are no longer available; the entire keyboard should be replaced. If you have one of these keyboards, you do not need to remove any keyboard components. See the preceding parts list for "Assembly 7: PS/2 ANPOS keyboard with integrated pointing device" on page 82 for new keyboard FRU part numbers.

Keyboard P/N	Language	Color
10J0902	US English	Pearl white/storm gray
10J0905	UK English	Pearl white/storm gray
10J0903	Spanish	Pearl white/storm gray
10J0904	French	Pearl white/storm gray
10J0793	US English	Pearl white/litho gray
10J0796	UK English	Pearl white/litho gray
10J0795	French	Pearl white/litho gray
10J0794	Spanish	Pearl white/litho gray
14J0601	US English	Iron gray
14J0694	UK English	Iron gray
14J0696	French	Iron gray
14J0695	Spanish	Iron gray

last update: March 22, 2007

Assembly 8: CANPOS keyboard with integrated pointing device

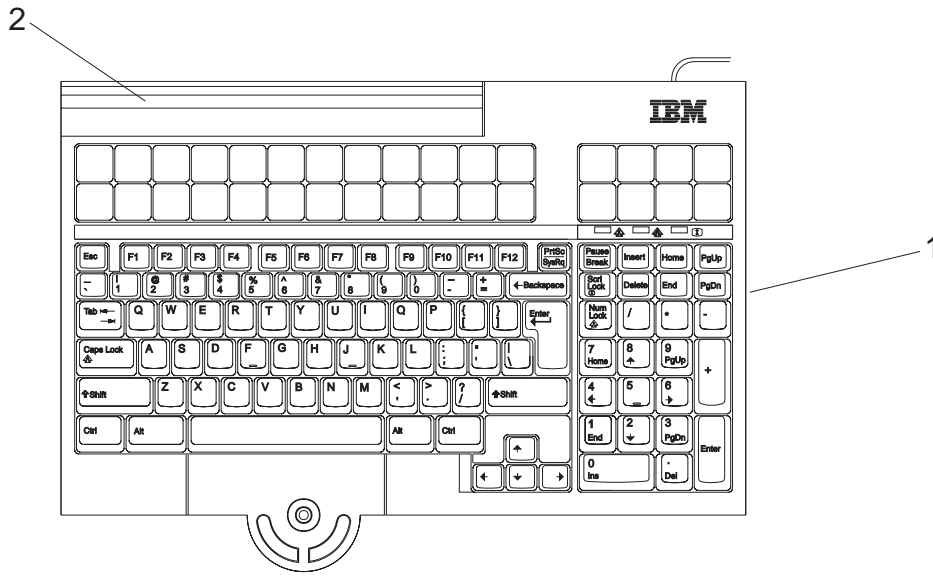

Asm-Index	Part Number	Units	Description
8-			Note: FRUs for the keyboards listed in the note following this parts list are no longer available; the entire keyboard should be replaced.
-1	42K0131	1	Keyboard, CANPOS, US English
-1	42K0172	1	Keyboard, CANPOS, UK English
-1	42K0175	1	Keyboard, CANPOS, French
-1	42K0178	1	Keyboard, CANPOS, Canadian French
-1	42K0181	1	Keyboard, CANPOS, Spanish
-1	42K0184	1	Keyboard, CANPOS, Brazilian Portuguese
-1	42K0187	1	Keyboard, CANPOS, German
-1	42K0197	1	Keyboard with MSR, CANPOS, US English
-1	42K0241	1	Keyboard with MSR, CANPOS, UK English
-1	42K0261	1	Keyboard with MSR, CANPOS, French
-1	42K0264	1	Keyboard with MSR, CANPOS, Canadian French
-1	42K0267	1	Keyboard with MSR, CANPOS, Spanish
-1	42K0270	1	Keyboard with MSR, CANPOS, Brazilian Portuguese
-1	42K0273	1	Keyboard with MSR, CANPOS, German
-	41J8032	1	Top cover, CANPOS keyboard, US English
-	41J8033	1	Top cover, CANPOS keyboard, UK English
-	41J8034	1	Top cover, CANPOS keyboard, French
-	41J8035	1	Top cover, CANPOS keyboard, Canadian French
-	41J8036	1	Top cover, CANPOS keyboard, Spanish
-	41J8037	1	Top cover, CANPOS keyboard, Brazilian Portuguese
-	41J8038	1	Top cover, CANPOS keyboard, German
-	41J9169	1	Internal card asm, CANPOS keyboard
-	54P8829	10	1 x 2 keycap, CANPOS keyboard (Quantity x10)
-	54P8830	10	1 x 1 keycap, CANPOS keyboard (Quantity x10)
-	42M5602	1	Split cable, CANPOS, integrated (0.7 m)
-	41J6864	1	Split cable, CANPOS, medium, black (1.275 m)
-	42M5600	1	Split cable, CANPOS, long (3.8 m)
-	42M5599	1	Straight connector, CANPOS or PS/2 ANPOS, short (0.7 m)
-	41J6860	1	Straight connector, CANPOS or PS/2 ANPOS, medium (1.475 m)
-	42M5597	1	Straight connector, CANPOS or PS/2 ANPOS, long (3.8 m)
-	41J9163	4	Screw (4), keyboard housing
-2	41J9164	1	MSR, three-track, for CANPOS keyboard
-	90X9640	1	Test card, MSR
-	30R0037	1	Cap, pointer (joystick) (10)
-			Note: The redesigned cap (with the textured surface) for the keyboard pointing device (joystick) is a consumable item; the customer is responsible for cap replacement. If you have this style cap, replacement caps can be purchased by calling 1-800-IBM-CALL (1-800-426-2255) in the US and Canada. Customers outside the US and Canada should contact their IBM representative.

Note: FRUs for the keyboards listed in the following table are no longer available; the entire keyboard should be replaced. See the preceding parts list for "Assembly 8: CANPOS keyboard with integrated pointing device" on page 86 for new keyboard FRU part numbers.

Keyboard P/N	Description	
54P8779	US English	no MSR
54P8780	UK English	
54P8781	French	
54P8782	Canadian French	
54P8783	Spanish	
54P8784	Brazilian Portuguese	
54P8785	German	
54P8786	US English	with MSR
54P8787	UK English	
54P8788	French	
54P8789	Canadian French	
54P8790	Spanish	
54P8791	Brazilian Portuguese	
54P8792	German	

last update: March 22, 2007

Assembly 9: Keyboard, USB and RS-485, 50-key, with or without MSR

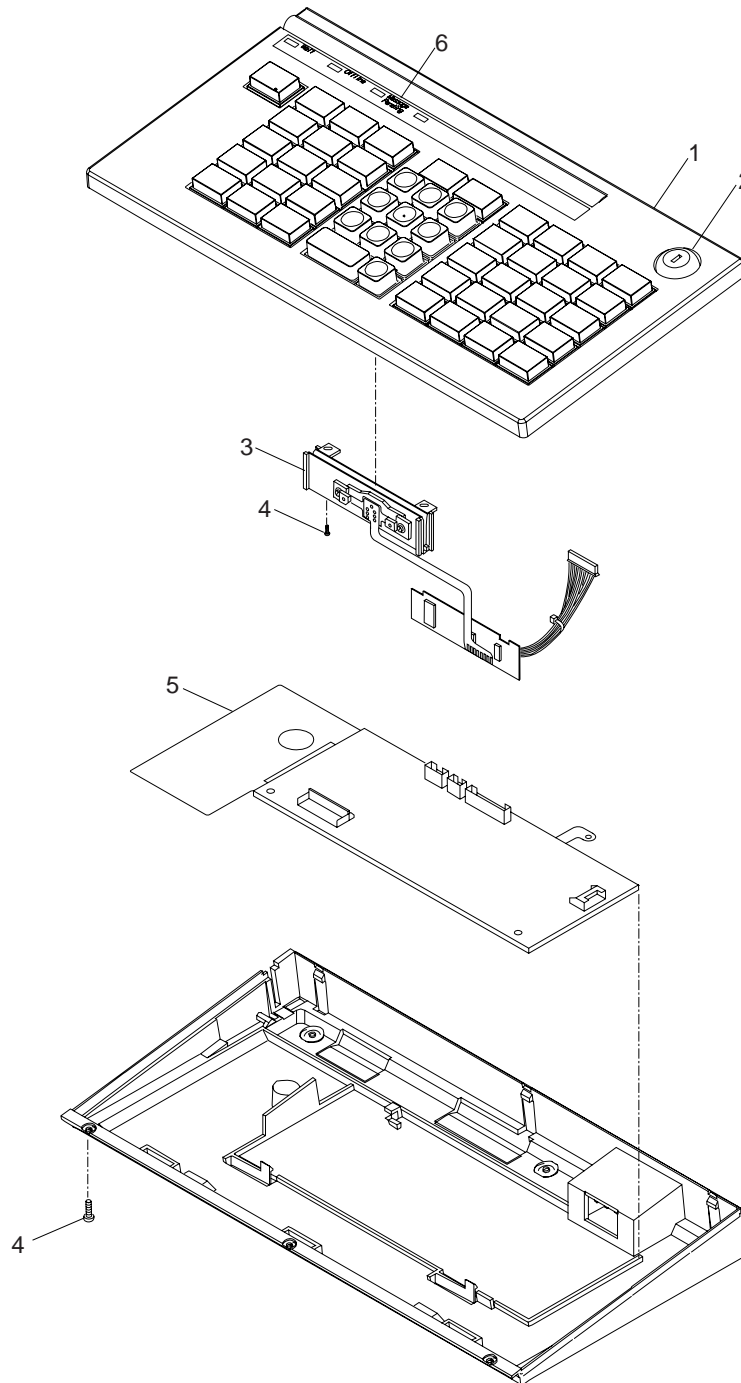

Asm-Index	Part Number	Units	Description
9-	41J7252	NR	Keyboard, USB, 50-key, with MSR, storm (light) gray
-	41J7253	NR	Keyboard, USB, 50-key, with MSR, iron (dark) gray
-	41J7251	NR	Keyboard, USB, 50-key, without MSR, storm (light) gray
-	41J7258	NR	Keyboard, RS-485, 50-key, with MSR, litho gray
-	41J7257	NR	Keyboard, RS-485, 50-key, without MSR
-1	41J7262	1	• Key button asm, top, with MSR, storm (light) gray
-1	41J7263	1	• Key button asm, top, with MSR, iron (dark) gray
-1	41J7261	1	• Key button asm, top, without MSR, storm (light) gray
-1	41J7268	1	• Key button asm, top, with MSR, RS-485
-1	41J7267	1	• Key button asm, top, without MSR, RS-485
-2	41J9195	1	• Lock and clip
-			• See Standard Lock Inserts in “Assembly 23: Other FRUs that are not shown” on page 120 for additional lock options.
-3	41J9166	1	• Magnetic stripe reader, USB
-3	41J9176	1	• Magnetic stripe reader, RS-485
-4	41J9163	4	• Screw
-5	41J9177	1	• Card asm, keyboard logic, USB
-5	41J9180	1	• Card asm, keyboard logic, RS-485
-6	41J9170	1	• LED asm, 4 lights
-	90X9640	2	• Test card, MSR (not illustrated)

Assembly 10: Keyboard, USB and RS-485, 50-key, with MSR and LCD

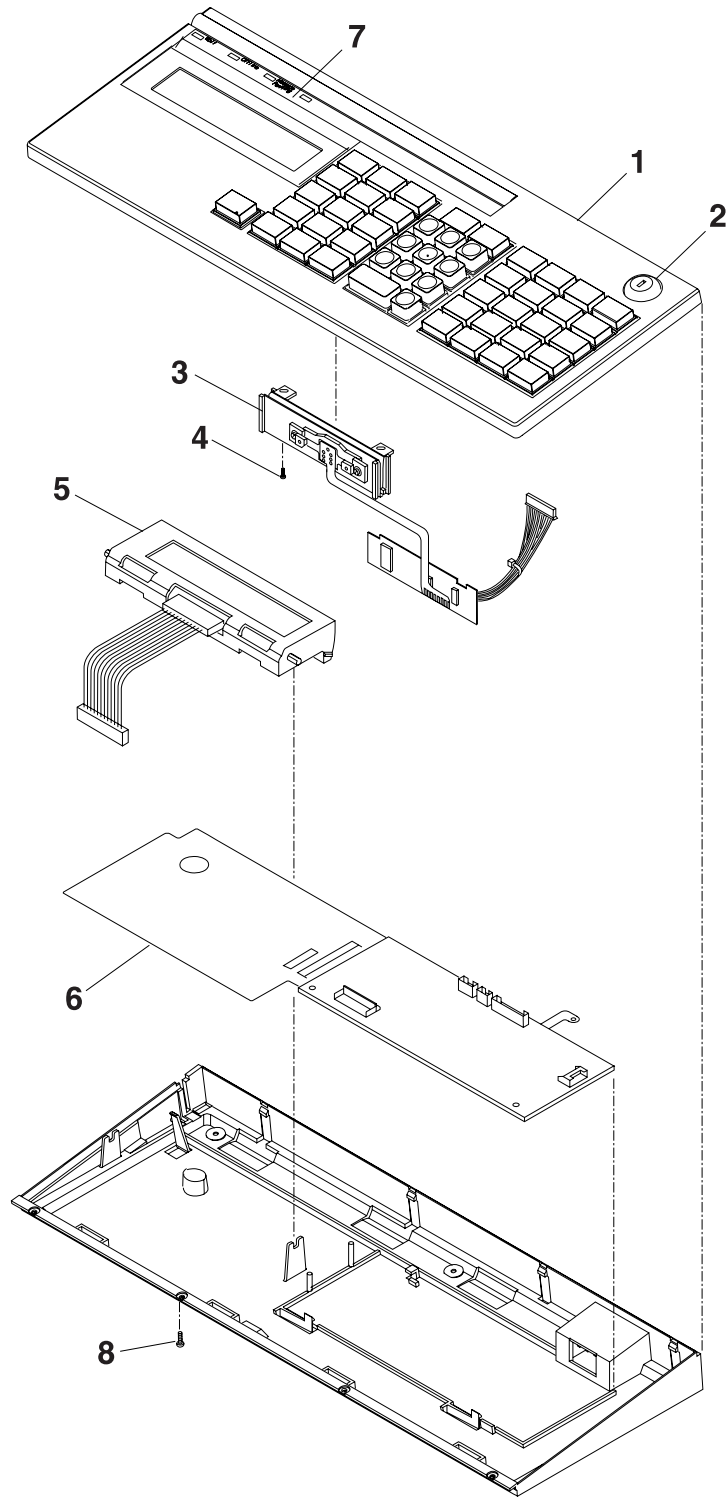

Asm-Index	Part Number	Units	Description
10-	41J7255	NR	Keyboard, USB, 50-key, with MSR and LCD
-	41J7256	NR	Keyboard, USB, 50-key, with MSR and LCD, iron (dark) gray
-	41J7260	NR	Keyboard, RS-485, 50-key, with MSR and LCD
-1	41J7265	1	• Key button asm, top
-1	41J7266	1	• Key button asm, top, iron (dark) gray
-1	41J7270	1	• Key button asm, top, RS-485
-2	41J9165	1	• Lock and clip
-			• See Standard Lock Inserts in “Assembly 23: Other FRUs that are not shown” on page 120 for additional lock options.
-3	41J9166	1	• Magnetic stripe reader
-3	41J9176	1	• Magnetic stripe reader, RS-485
-4	41J9163	1	• Screw
-5	41J9178	1	• Display asm, operator, with cable
-5	41J9179	1	• Display asm, operator, with cable, RS-485
-6	41J9167	1	• Card asm, keyboard logic
-6	41J9175	1	• Card asm, keyboard logic, RS-485
-7	41J9170	1	• LED asm, 4 lights
-8	41J9163	AR	• Screw
-	90X9640	1	• Test card, MSR (not illustrated)

Assembly 11: Keyboard, USB, 50-key, with JUCC (Japan)

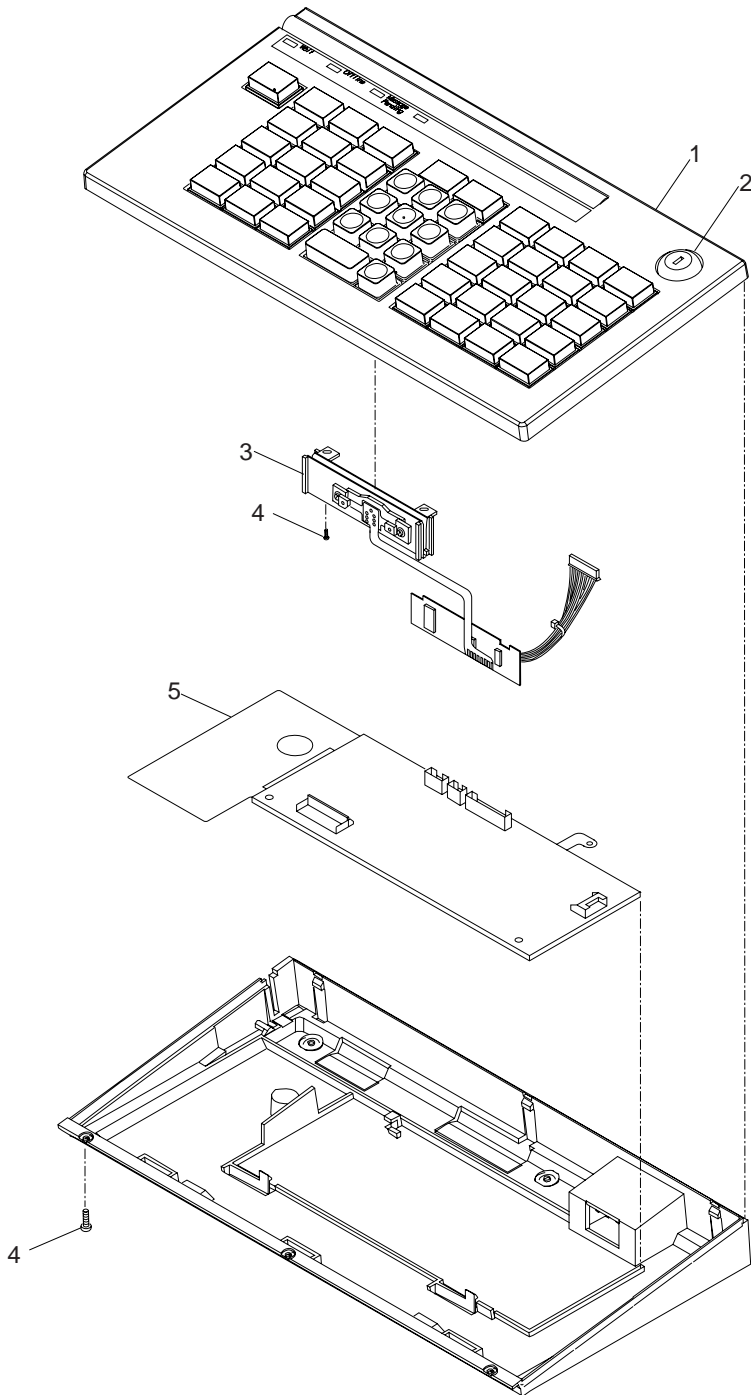

Asm-Index	Part Number	Units	Description
11-	41J7254	NR	Keyboard, USB, Japan, 50-key, with MSR
-	41J7259	NR	Keyboard, RS-485, Japan, 50-key, with MSR
-1	41J7264	1	• Key button asm, top, without MSR
-1	41J7269	1	• Key button asm, top, with MSR, RS-485
-2	41J9174	1	• Lock and clip
-			• See Standard Lock Inserts in “Assembly 23: Other FRUs that are not shown” on page 120 for additional lock options.
-3	41J9173	1	• Magnetic stripe reader
-4	41J9163	4	• Screw
-5	41J9177	1	• Card asm, keyboard logic, USB
-5	41J9180	1	• Card asm, keyboard logic, RS-485
-	48G9045	1	• Test card and cleaning card, MSR (not illustrated)

Assembly 12: Keyboard, USB and Modifiable Layout RS-485, 133-key, with MSR

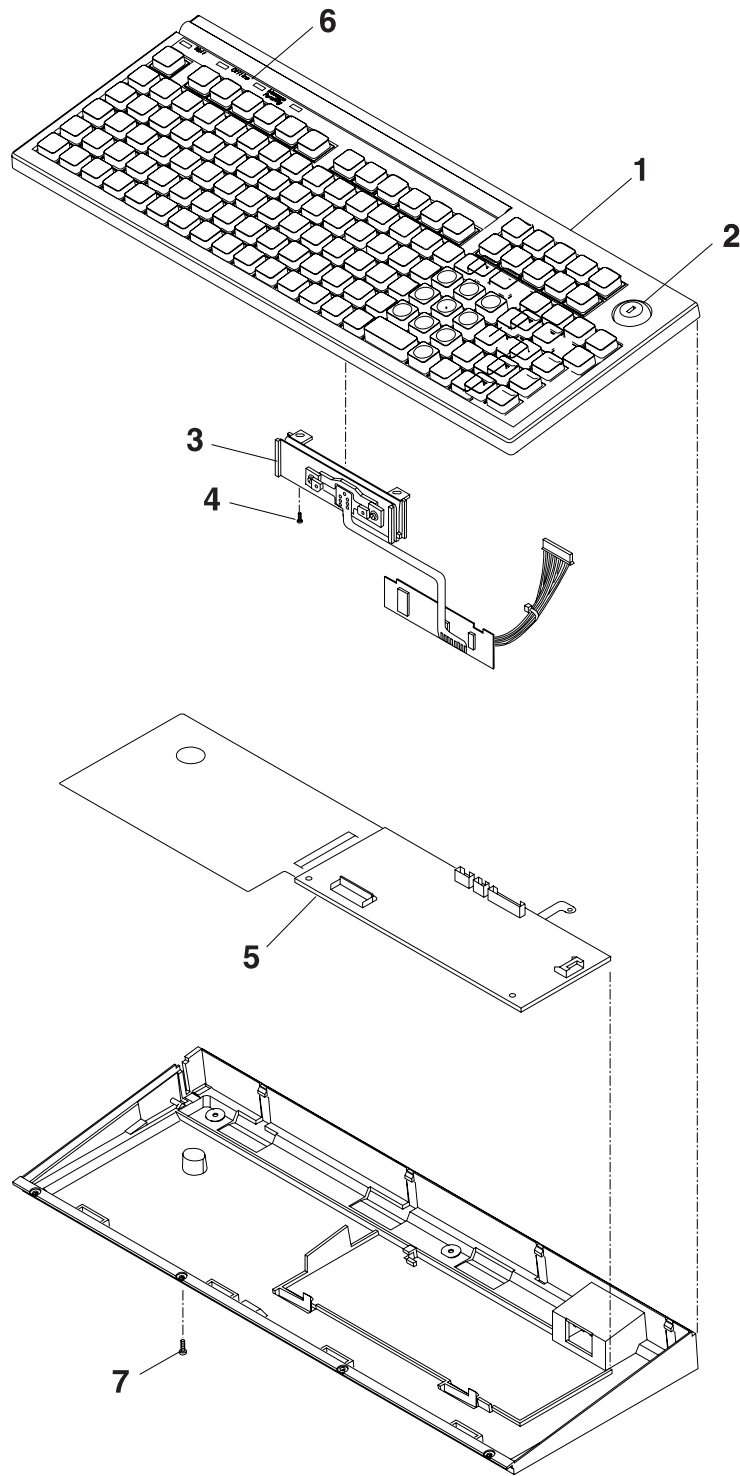

Asm-Index	Part Number	Units	Description
12-	41J8020	NR	Keyboard, USB, 133-key, with MSR
-	41J8021	NR	Keyboard, RS-485, Modifiable Layout, 133-key, with MSR
-1	41J8023	1	• Key button asm, top, USB
-1	41J8024	1	• Key button asm, top, RS-485
-2	41J9165	1	• Lock and clip
-			• See Standard Lock Inserts in “Assembly 23: Other FRUs that are not shown” on page 120 for additional lock options.
-3	41J9166	1	• Magnetic stripe reader, USB
-3	41J9176	1	• Magnetic stripe reader, RS-485
-4	41J9163	1	• Screw
-5	41J9167	1	• Card asm, keyboard logic, USB
-5	41J9175	1	• Card asm, keyboard logic, RS-485
-6	41J9170	1	• LED asm, 4 lights
-7	41J9163	AR	• Screw
-	90X9640	1	• Test card, MSR (not illustrated)

Assembly 13: Keyboard, USB and RS-485, ANPOS, with MSR

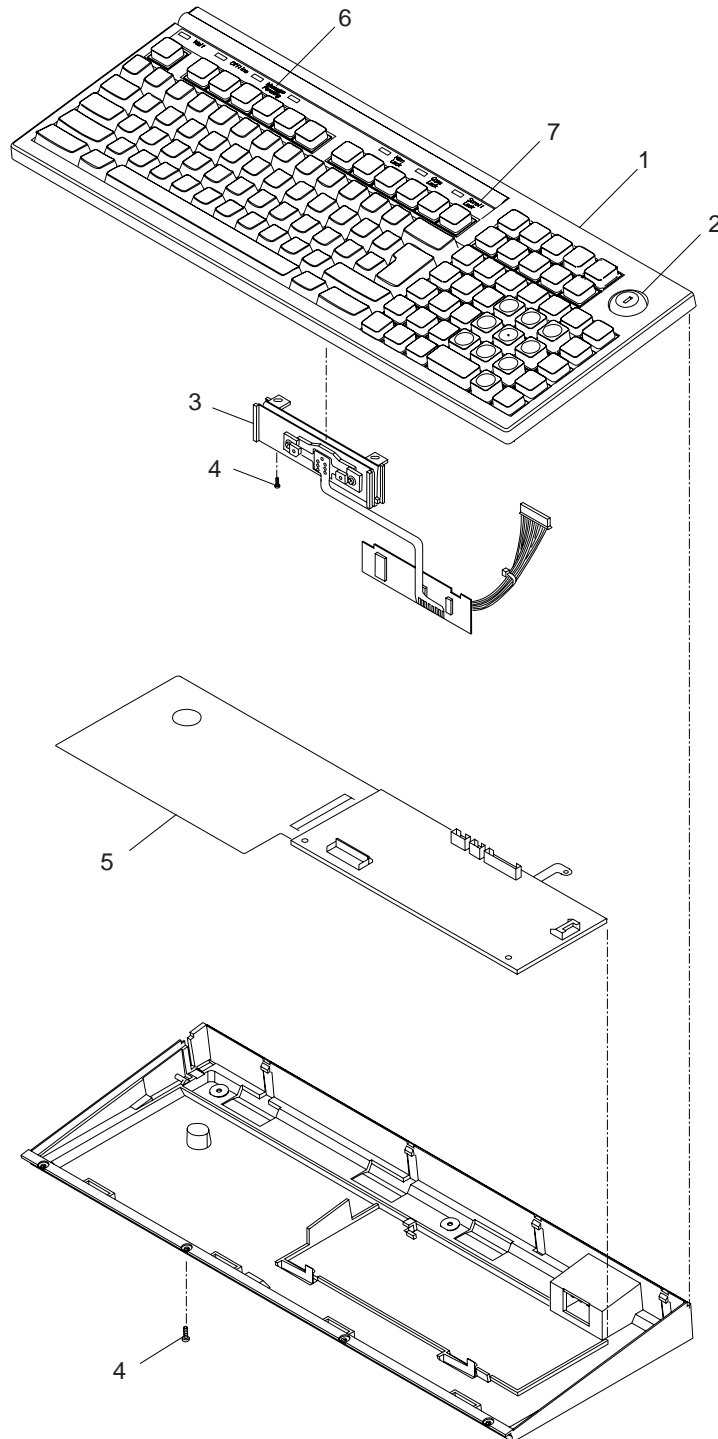

Asm- Index	Part Number	Units	Description
13-	41J6911	NR	Keyboard, USB, ANPOS, with MSR, US English, storm (light) gray
-	41J6913	NR	Keyboard, USB, ANPOS, with MSR, US English, iron (dark) gray
-	41J6959	NR	Keyboard, RS-485, ANPOS, with MSR, US English, RS-485
-	41J6895	NR	Keyboard, USB, ANPOS, with MSR, UK English, storm (light) gray
-	41J6897	NR	Keyboard, USB, ANPOS, with MSR, UK English, iron (dark) gray
-	41J6949	NR	Keyboard, RS-485, ANPOS, with MSR, UK English, RS-485
-	41J6907	NR	Keyboard, USB, ANPOS, with MSR, Spanish, storm (light) gray
-	41J6909	NR	Keyboard, USB, ANPOS, with MSR, Spanish, iron (dark) gray
-	41J6955	NR	Keyboard, RS-485, ANPOS, with MSR, Spanish, RS-485
-	41J6899	NR	Keyboard, USB, ANPOS, with MSR, French, storm (light) gray
-	41J6901	NR	Keyboard, USB, ANPOS, with MSR, French, iron (dark) gray
-	41J6951	NR	Keyboard, RS-485, ANPOS, with MSR, French, RS-485
-	41J6891	NR	Keyboard, USB, ANPOS, with MSR, Canadian French, storm (light) gray
-	41J6893	NR	Keyboard, USB, ANPOS, with MSR, Canadian French, iron (dark) gray
-	41J6947	NR	Keyboard, RS-485, ANPOS, with MSR, Canadian French, RS-485
-	41J6903	NR	Keyboard, USB, ANPOS, with MSR, German, storm (light) gray
-	41J6905	NR	Keyboard, USB, ANPOS, with MSR, German, iron (dark) gray
-	41J6953	NR	Keyboard, RS-485, ANPOS, with MSR, German, RS-485
-	41J6887	NR	Keyboard, USB, ANPOS, with MSR, Brazilian Portuguese, storm (light) gray
-	41J6889	NR	Keyboard, USB, ANPOS, with MSR, Brazilian Portuguese, iron (dark) gray
-	41J6945	NR	Keyboard, RS-485, ANPOS, with MSR, Brazilian Portuguese, RS-485
-	92F6315	NR	Keyboard, RS-485, ANPOS, with MSR, Danish, RS-485
-	92F6316	NR	Keyboard, RS-485, ANPOS, with MSR, Finnish and Swedish, RS-485
-	92F6317	NR	Keyboard, RS-485, ANPOS, with MSR, Norwegian, RS-485
-1	41J8065	1	• Key button asm, top, US English, USB, storm (light) gray
-1	41J8066	1	• Key button asm, top, US English, USB, iron (dark) gray
-1	41J8075	1	• Key button asm, top, US English, RS-485
-1	41J8057	1	• Key button asm, top, UK English, USB, storm (light) gray
-1	41J8058	1	• Key button asm, top, UK English, USB, iron (dark) gray
-1	41J8070	1	• Key button asm, top, UK English, RS-485
-1	41J8063	1	• Key button asm, top, Spanish, USB, storm (light) gray
-1	41J8064	1	• Key button asm, top, Spanish, USB, iron (dark) gray
-1	41J8073	1	• Key button asm, top, Spanish, RS-485
-1	41J8059	1	• Key button asm, top, French, USB, storm (light) gray
-1	41J8060	1	• Key button asm, top, French, USB, iron (dark) gray
-1	41J8071	1	• Key button asm, top, French, RS-485
-1	41J8055	1	• Key button asm, top, Canadian French, USB, storm (light) gray
-1	41J8056	1	• Key button asm, top, Canadian French, USB, iron (dark) gray
-1	41J8069	1	• Key button asm, top, Canadian French, RS-485
-1	41J8061	1	• Key button asm, top, German, USB, storm (light) gray
-1	41J8062	1	• Key button asm, top, German, USB, iron (dark) gray
-1	41J8072	1	• Key button asm, top, German, RS-485
-1	93F1937	1	• Key button asm, top, Italian, RS-485
-1	41J8053	1	• Key button asm, top, Brazilian Portuguese, USB, storm (light) gray
-1	41J9168	1	• Key button asm, top, Brazilian Portuguese, USB, iron (dark) gray
-1	41J8068	1	• Key button asm, top, Brazilian Portuguese, RS-485
-2	41J9165	1	• Lock and clip
-			• See Standard Lock Inserts in "Assembly 23: Other FRUs that are not shown" on page 120 for additional lock options.
-3	41J9166	1	• Magnetic stripe reader, USB
-3	41J9176	1	• Magnetic stripe reader, RS-485
-4	41J9163	AR	• Screw
-5	41J9167	1	• Card asm, keyboard logic, USB

Assembly 13: (continued)

last update: March 22, 2007

Asm- Index	Part Number	Units	Description
-5	41J9175	1	• Card asm, keyboard logic, RS-485
-6	41J9170	AR	• LED asm, 4 lights
-7	41J9171	AR	• LED asm, 3 lights
-	90X9640	1	• Test card, MSR (not illustrated)

last update: March 22, 2007

Assembly 14: Keyboard, USB and RS-485, ANKPOS, with MSR (Japan)

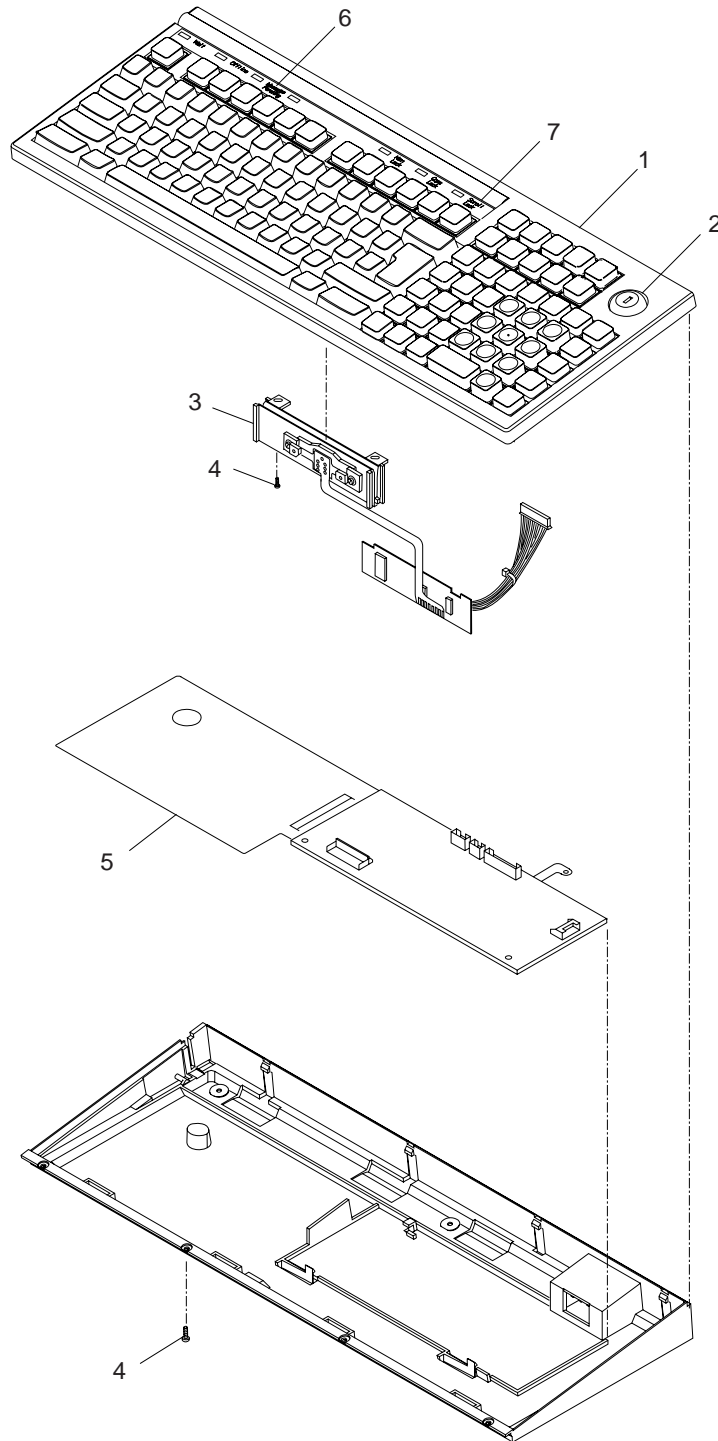

Asm-Index	Part Number	Units	Description
14-	41J6915	NR	Keyboard, USB, ANKPOS, with MSR, storm (light) gray
-	41J6957	NR	Keyboard, RS-485, ANKPOS/2, with MSR
-1	41J8067	1	• Key button asm, USB, top, Japan, storm (light) gray
-1	41J7260	1	• Key button asm, RS-485, top, Japan
-2	41J9174	1	• Lock and clip
-			• See Standard Lock Inserts in “Assembly 23: Other FRUs that are not shown” on page 120 for additional lock options.
-3	41J9173	1	• Magnetic stripe reader
-4	41J9163	AR	• Screw
-5	41J9167	1	• Card asm, keyboard logic
-6	41J9217	AR	• LED asm, ANKPOS, 4 lights
-7	41J9171	AR	• LED asm, 3 lights
-	48G9045	1	• Test and cleaning cards, MSR (not illustrated)

Assembly 15: Keyboard-V, USB (Japan)

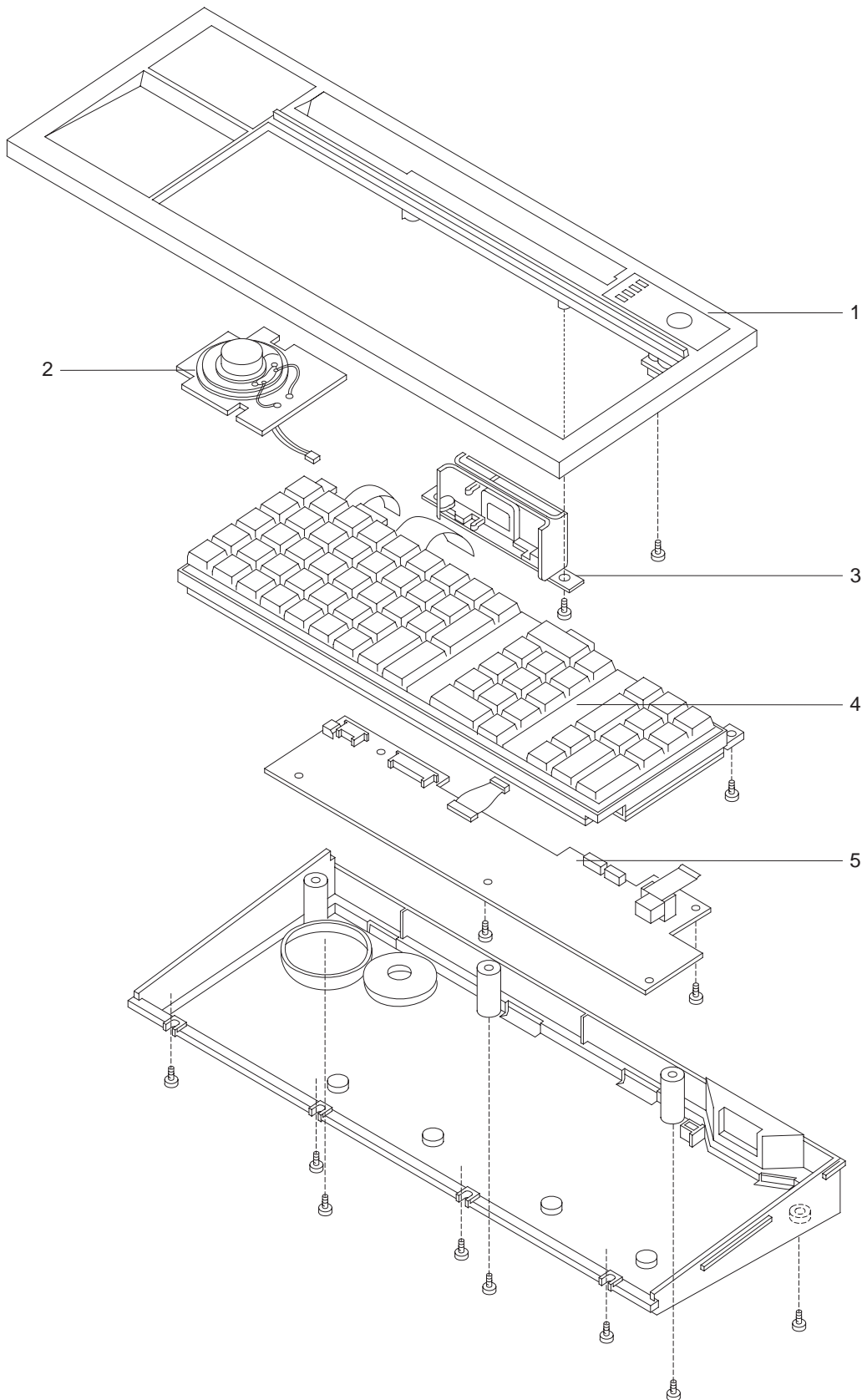

Asm- Index	Part Number	Units	Description
15-1	95F3184	1	Top cover
-2	95F3181	1	Speaker asm
-3	95F3182	1	Magnetic stripe reader
-4	95F3180	1	Keyboard matrix unit, which includes the following parts:
-	48G9012	AR	• Key top, cap, gum dome (single)
-	48G9013	AR	• Key top, cap, gum dome (double)
-	48G9028	AR	• Quadruple keytop cap
-	48G9014	AR	• Ten-key set
-	48G9015	AR	• Dummy key cover (single)
-	48G9029	AR	• Dummy key cover (1x5)
-5	47L8035	1	Control card
-	95F3229	1	Mode switch key

Assembly 16: USB PLU keyboard/display (Japan, Korea)

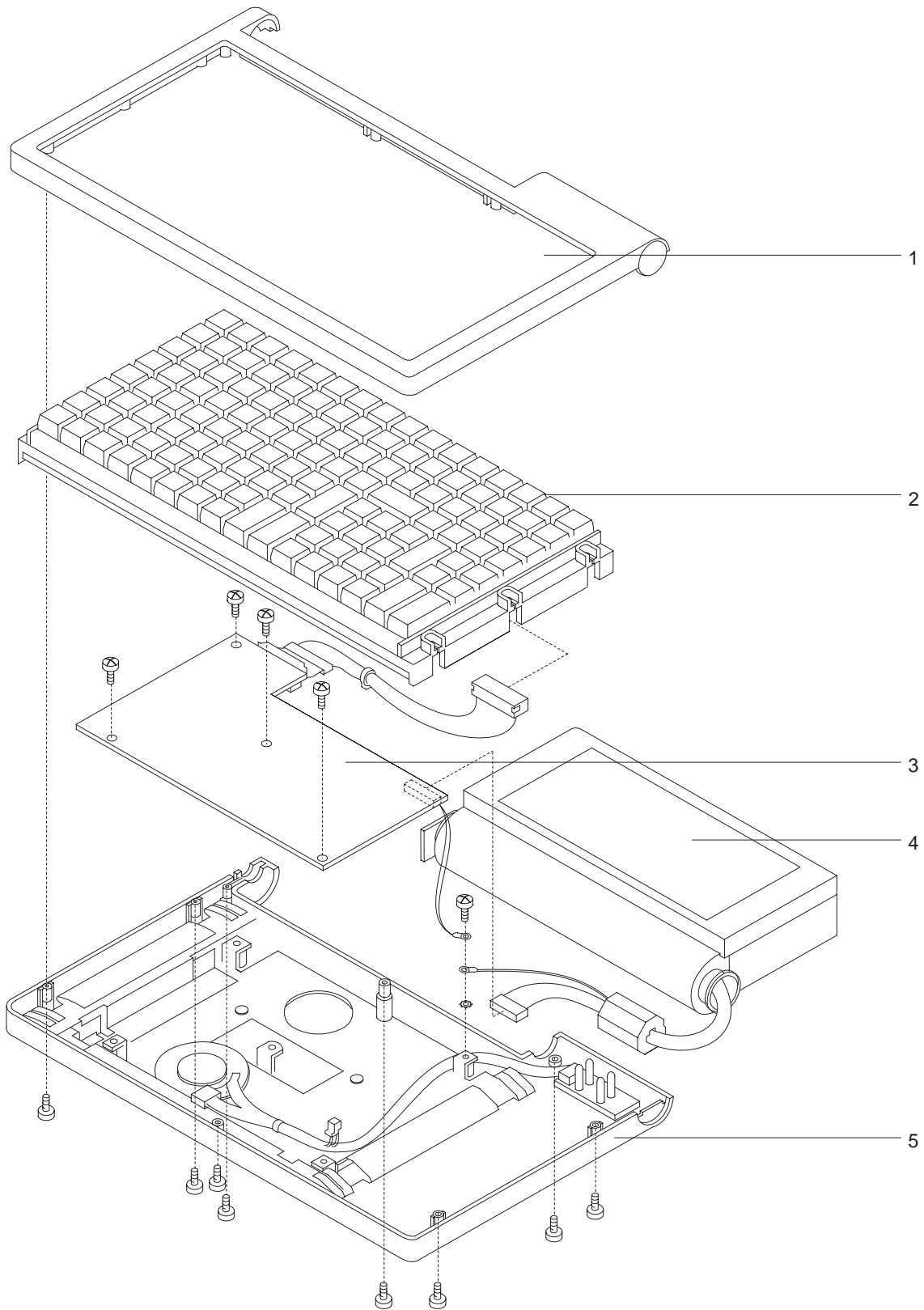

Asm-Index	Part Number	Units	Description
16-1	95F3195	1	Top cover (for Japan)
-1	95F3196	1	Top cover (for Korea)
-2	94G3245	1	Keyboard matrix unit, which includes the following parts:
-	48G9012	1	• Key top, cap, gum dome (single)
-	48G9013	1	• Key top, cap, gum dome (double)
-	48G9028	1	• Quadruple keytop cap
-	48G9014	1	• Ten-key set
-	48G9015	1	• Dummy key cover (single)
-	48G9029	1	• Dummy key cover (1x5)
-3	47F8031	1	Control card
-4	47L8032	1	VFD unit (for Japan)
-4	47L8040	1	VFD unit (for Korea)
-5	95F3278	1	Bottom cover (for Japan)
-5	48G9027	1	Bottom cover (for Korea)

Assembly 17: USB PLU extension box (Japan, Korea)

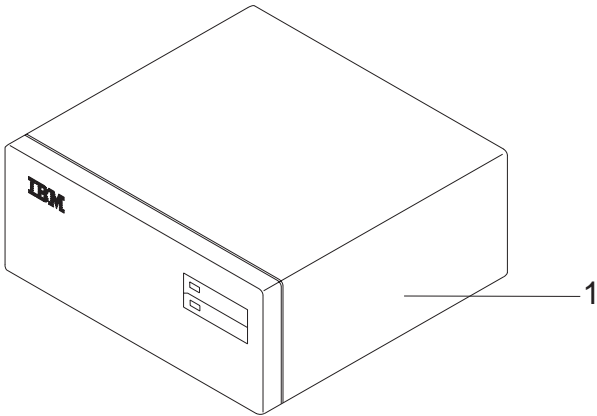

Asm- Index	Part Number	Units	Description
17-1	47L8033	1	PLU extension box

Assembly 18: Fillers for character/graphics display and printer (SurePOS 700 Japan and Korea)

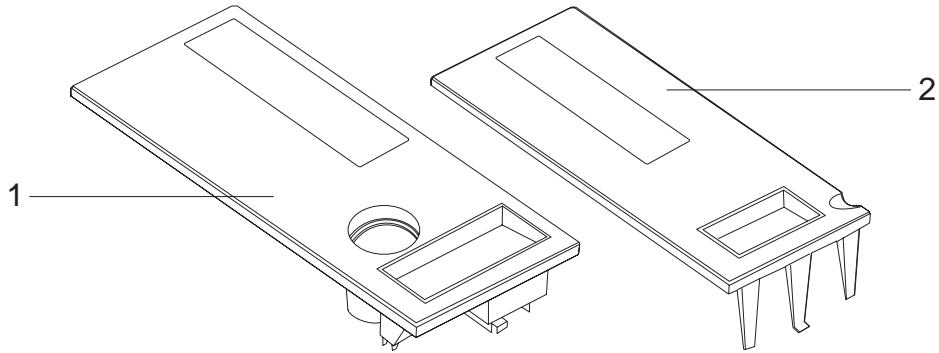

Asm- Index	Part Number	Units	Description
18-1	47L7995	1	Character/graphics display filler
-2	47L7994	1	PRT filler, double-byte character set

Assembly 19: Fillers and table-top slanted I/O tray (SurePOS 700)

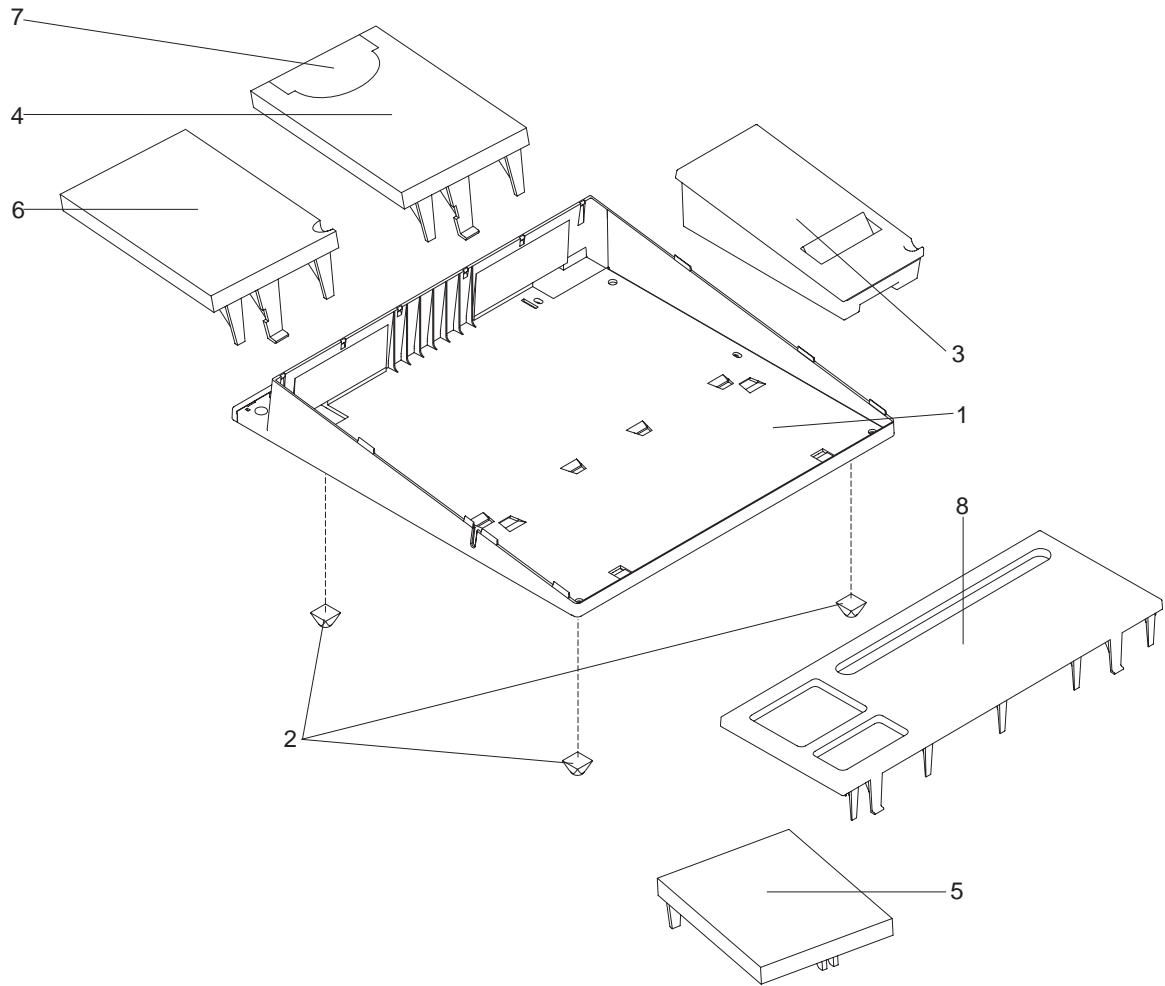

Asm- Index	Part Number	Units	Description
19-1	30L6320	1	Table-top slanted I/O Tray, storm (light) gray
-1	34L4289	1	Table-top slanted I/O Tray, iron (dark) gray
-2	30L6228	5	• Foot
-3	30L6322	1	Printer filler/narrow credit card holder, storm (light) gray, pearl white
-3	10N1253	1	Printer filler/narrow credit card holder, iron (dark) gray
-4	30L6218	1	Display filler panel, storm (light) gray
-4	10N1248	1	Display filler panel, iron (dark) gray
-5	30L6216	1	Keyboard filler panel, storm (light) gray
-5	10N1193	1	Keyboard filler panel, iron (dark) gray
-6	30L6217	1	Printer filler/wide credit card holder, storm (light) gray
-6	10N1259	1	Printer filler/wide credit card holder, iron (dark) gray
-7	30L6230	1	Filler insert for display filler panel, storm (light) gray
-7	10N1274	1	Filler insert for display filler panel, iron (dark) gray
-8	30L6365	1	Keyboard replacement filler panel, storm (light) gray
-8	34L4315	1	Keyboard replacement filler panel, iron (dark) gray

Assembly 20: Countertop non-keyboard integration tray and filler panels (SurePOS 500)

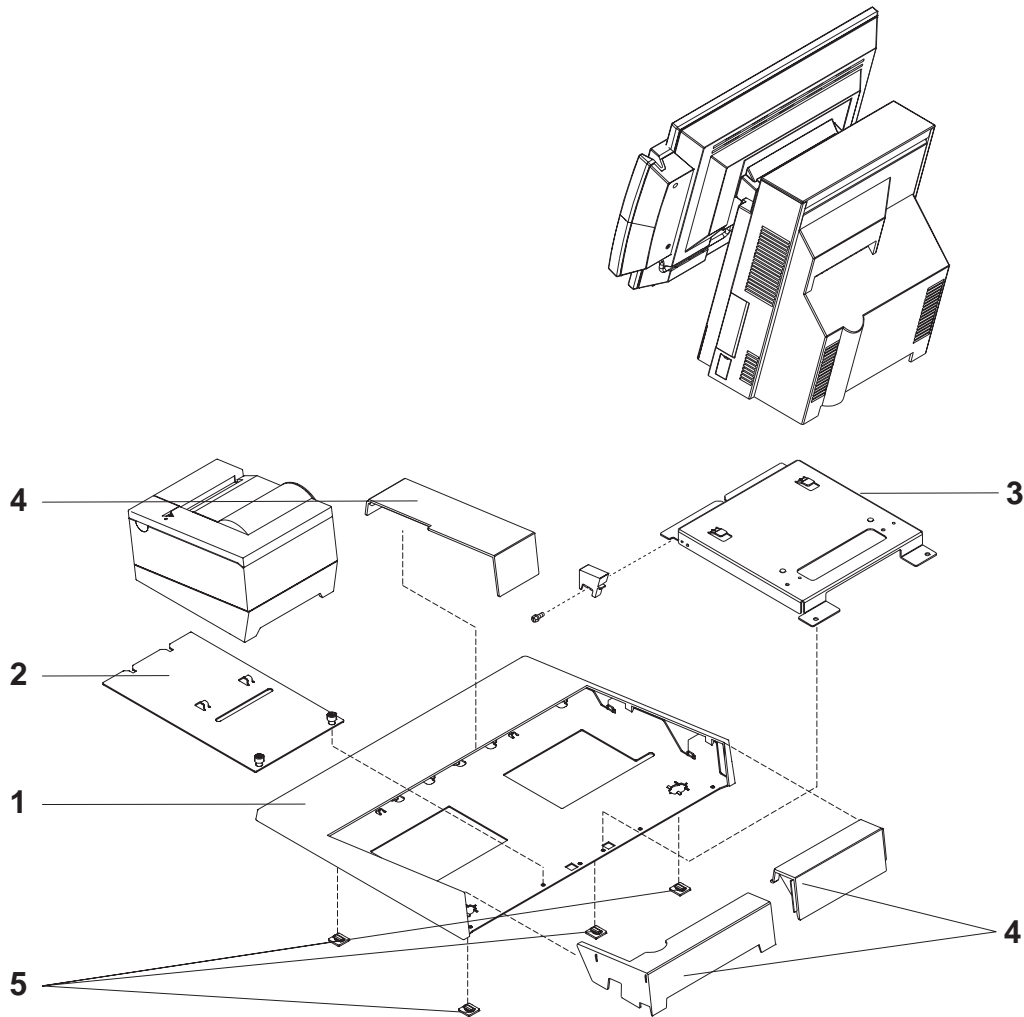

Asm- Index	Part Number	Units	Description
20-1	41D0261	1	Plate and fence, countertop mount
-1	41D0213	1	Plate and fence, countertop mount, fits filler panel for non-printer use
-2	41D0211	1	Plate, printer mounting
-3	41D0207	1	Plate, terminal mounting (includes screws)
-4	14R1998	1	Panels, filler
-	41D0212	1	Hardware, non-keyboard integration tray (kit - includes feet and screws, not illustrated)
-	41D0209	1	FRU, printer filler panel kit, non-keyboard (not shown)
-5	93F0663	1	Feet, rubber (5)

Assembly 21: Cash drawer non-keyboard integration tray and filler panels (SurePOS 500)

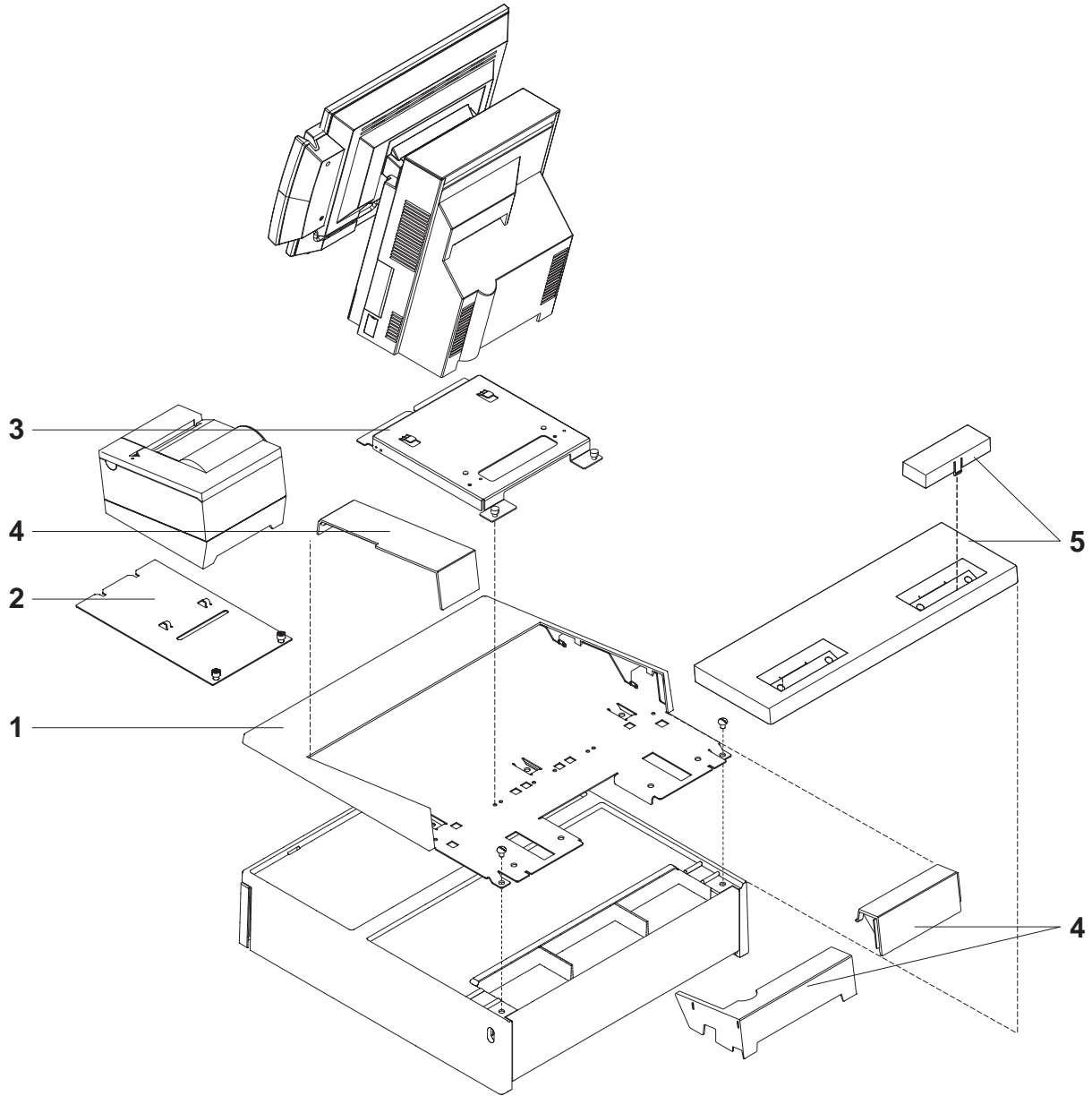

Asm- Index	Part Number	Units	Description
21-1	41D0210	1	Plate and fence, cash drawer mount
-2	41D0211	1	Plate, printer mounting
-3	41D0207	1	Plate, terminal mounting
-4	14R1998	1	Panels, filler
-5	20P0308	1	Cover, modesty
-	41D0212	1	Hardware, non-keyboard integration tray (kit - includes screws, not illustrated)
-	41D0209	1	FRU, printer filler panel kit, non-keyboard (not shown)

Assembly 22: Countertop and cash drawer keyboard integration tray and filler panels (SurePOS 500)

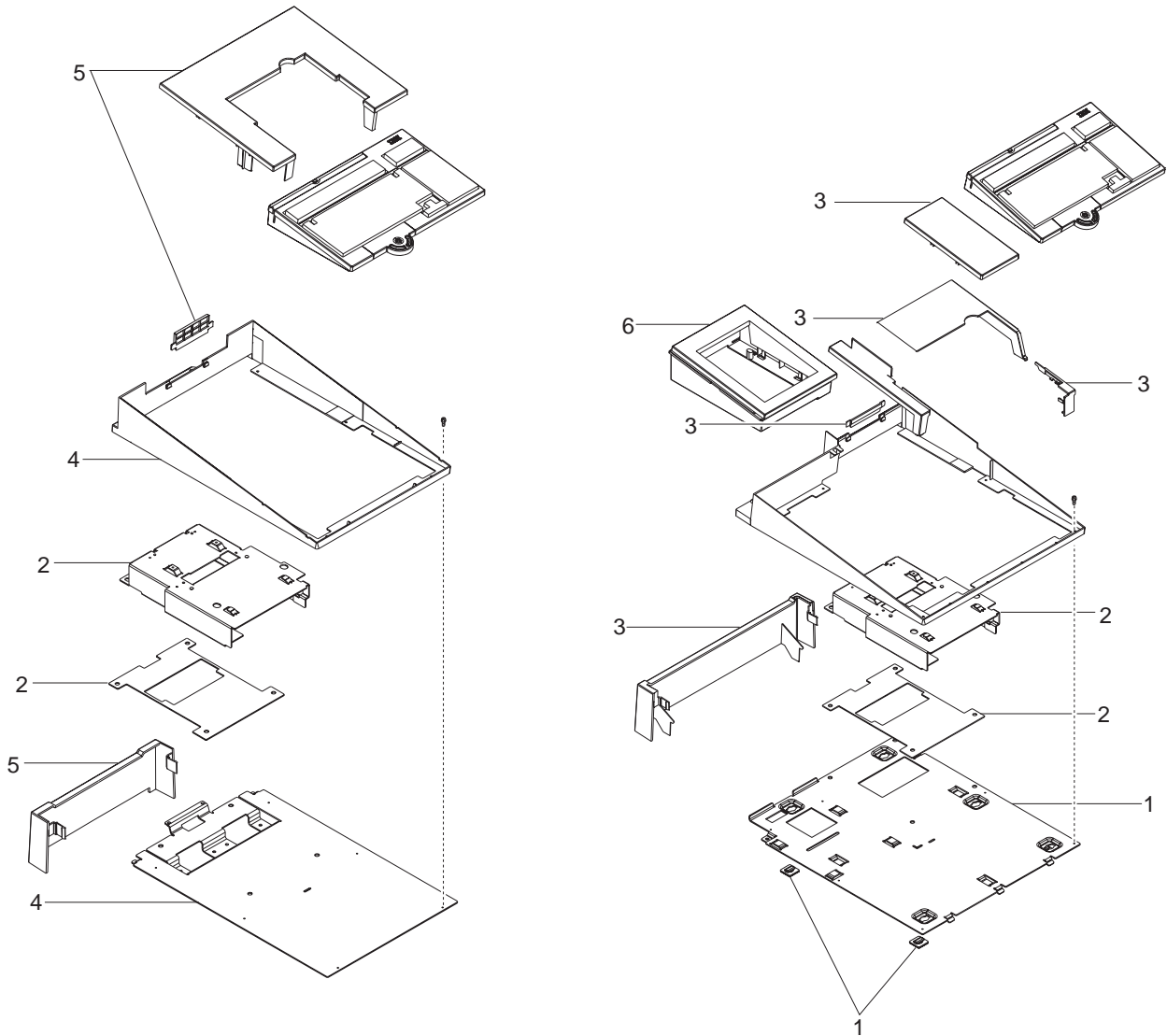

Asm-Index	Part Number	Units	Description
22-1	41D0214	1	Plate/fence asm, wide cash drawer or countertop (includes hardware)
-		1	• M6x8 screws, cash drawer mount
-		1	• Fence, wide
-		1	• M3x5 screws, fence mounting
-		1	• Feet, rubber
-2	41D0208	1	Plate asm, terminal mounting
-		1	• Plate, terminal mount insulator
-		1	• Washer, insulating
-		1	• M6X12 screws, terminal mount
-3	14R0024	1	Filler panels, wide and countertop
-		1	• Cover, keyboard filler, retail keyboard
-		1	• Cover, terminal filler, wide tray and countertop
-		1	• Cover, wide CD rear curtain
-		1	• Fence, plug
-4	41D0215	1	Plate/fence asm, narrow cash drawer or countertop (includes hardware)
-		1	• M6x8 screws, cash drawer mount
-		1	• Fence, narrow
-		1	• M3x5 screws, fence mounting
-5	14R0023	1	Filler panels, narrow
-		1	• Cover, keyboard filler, retail keyboard
-		1	• Cover, narrow CD rear curtain
-		1	• Fence, plug
-6	47P9273	1	Printer footprint adapter, SST to 4610, iron gray
-		1	• Base, SST to 4610 footprint, iron gray
-		1	• Panel, SST to 4610 footprint, iron gray
-		1	• Feet, printer base
-	41D0216	1	Retail integration, installation hardware kit (not shown)
-		1	• M3x5 screws, fence mounting (6)
-		1	• M5x10 screws, system unit mounting (4)
-		1	• M6x12 screws, terminal mounting (4)
-		1	• Washer, insulation, for terminal mount screws (4)
-		1	• M6x8 screws, CD plate mounting (4)
-		1	• Feet, CD plate countertop mounting (5)

Assembly 23: Other FRUs that are not shown

Asm-Index	Part Number	Units	Description
23-			Cable assemblies
-	42M5593	1	Cable, PS/2 mouse and keyboard, pebble gray (0.65 m)
-	42M5591	1	Cable, PS/2 mouse and keyboard, pebble gray (3.8 m)
-	42M5596	1	Cable, PS/2 mouse and keyboard, black (0.65 m)
-	42M5594	1	Cable, PS/2 mouse and keyboard, black (3.8 m)
-	42M5639	AR	Cable asm, keyboard or USB 40-character LCD, powered USB (0.65 m)
-	42M5606	AR	Cable asm, keyboard or all USB 40-character LCD or PLU extension box, powered USB (3.8 m)
-	42M5608	1	Cable asm, keyboard, USB (0.65 m)
-	42M5610	1	Cable asm, keyboard, USB (3.8 m)
-	47L8067	1	Cable asm, keyboard-V, powered USB (0.7 m)
-	47L8064	1	Cable asm, keyboard-V, powered USB (3.8 m)
-	42M5653	1	Cable asm, cash drawer, integrated
-	41J6856	1	Cable asm, cash drawer, medium (1.12 m)
-	42M5653	1	Cable asm, cash drawer, integrated (0.5 m) (cable 3)
-	42M5659	1	Cable asm, cash drawer, distributed (1.4 m) (cable 3)
-	42M5657	1	Cable asm, cash drawer, distributed (3.8 m) (cable 3)
-	42M5630	AR	Cable asm, 40-character VFD, USB (0.7 m)
-	42M5632	AR	Cable asm, 40-character VFD, USB (3.8 m)
-	42M5667	1	Cable, analog video, long (3.8 m)
-	42M5668	1	Cable, analog video to DVI-I adapter (0.3 m)
-	41D0301	1	Cable, LCD, powered USB, medium (1.8 m)
-	42M5626	1	Cable, display, distributed (0.8 m)
-	42M5663	1	Cable, display, distributed (3.8 m)
-	41J6831	1	Cable, display, integrated, RS-232 for Garage
-	41J6833	1	Cable, display, integrated, RS-485 for Garage
-	41D0303	1	Cable, keyboard, USB, medium (1.475 m)
-	41D0301	1	Cable, keyboard, powered USB, medium
-	42M5603	1	Cable, keyboard, double-byte character set, short
-	42M5605	1	Cable, keyboard, double-byte character set, long
-	42M5615	1	Cable, keyboard, distributed, RS-485
-	42M5612	1	Cable, keyboard, integrated, RS-485
-	41D0307	1	Cable, keyboard, integrated, RS-485 (1.475 m)
-	42M5622	1	Cable, keyboard, integrated, RS-485 to PS/2
-	41D0305	1	Cable, keyboard, integrated, RS-485 to PS/2 (1.475 m)
-	42M5625	1	Cable, keyboard, distributed, RS-485 to PS/2
-	42M5662	1	Dongle, cash drawer, OEM
-	41J9250	1	Cash drawer top cover, light (storm) gray
-	41J9272	1	Cash drawer top cover, dark (litho) gray
-	41J9490	1	Flip-top cash drawer hardware kit
-	16K9075	1	CRT power extension cable (1.7 m)
-	42M5628	1	CRT signal extension cable (1.7 m)
-	39M5377	1	Universal coupler cord
-	41D0313	1	Y-Cable, mouse and keyboard (4840 Models 521, 541, 542, 561, and 562)
-	41D0312	1	Y-Cable, mouse and keyboard, thin black (4840 Models 531, 532, 551, 552, 611, 621, 622, 651, and 652)
-	42M5637	1	Y-Cable, RS-485 Port 4
-	42M5616	1	Y-Cable, RS-485 keyboard Port 5
-	72H3118	1	Y-Cable, RS-485 Port 9
-			External drives
-	06P5223	1	Floppy disk drive

Asm-Index	Part Number	Units	Description
-	41D7531	1	CD-ROM drive
-			Standard lock inserts
-	41J8077	1	Non-operative lock
-	41J8078	1	Lock insert 2 for cash drawer and keyboard
-	41J8079	1	Lock insert 3 for cash drawer and keyboard
-	41J8080	1	Lock insert 4 for cash drawer and keyboard
-	41J8081	1	Lock insert 5 for cash drawer and keyboard
-	41J8082	1	Lock insert 6 for cash drawer and keyboard
-	41J8083	1	Lock insert 7 for cash drawer and keyboard
-	41J8084	1	Lock insert 8 for cash drawer and keyboard
-	41J8085	1	Lock insert 9 for cash drawer and keyboard
-	41J8086	1	Lock insert 10 for cash drawer and keyboard
-	41J8087	1	Lock insert 11 for cash drawer and keyboard
-			Cash drawer premium lock inserts
-	41J8088	1	Premium lock insert 1 for cash drawer
-	41J8089	1	Premium lock insert 2 for cash drawer
-	41J8090	1	Premium lock insert 3 for cash drawer
-	41J8091	1	Premium lock insert 4 for cash drawer
-	41J8092	1	Premium lock insert 5 for cash drawer
-	41J8093	1	Premium lock insert 6 for cash drawer
-	41J8094	1	Premium lock insert 7 for cash drawer
-	41J8095	1	Premium lock insert 8 for cash drawer
-	41J8096	1	Premium lock insert 9 for cash drawer
-	41J8097	1	Premium lock insert 10 for cash drawer

Appendix A. Understanding USB

USB advantages	123
USB device identification and enumeration process	123
Voltage for USB connectors.	124

This section describes the Universal Serial Bus (USB) technology and the necessary information to communicate with the human interface devices (HID). This section also explains the powered USB connectors.

For information on USB as it relates to the Point-of-Sale Subsystem, refer to the *Point-of-Sale Subsystem Programming Reference and User's Guide*.

USB advantages

IBM Store Systems use USB technology to provide open-system interfaces. Advantages of this technology include:

- Plug-and-Play capability
- Cascading of devices
- Additional communication bandwidth
- One-size-fits-all connections for low-speed and full-speed point-of-sale peripherals
- Hot plugging of USB I/O devices

USB device identification and enumeration process

The process the host uses when an USB device is attached to or removed from the USB is referred to as *bus enumeration*. Bus enumeration identifies and manages the necessary device state changes during attachment and removal.

For more information about the USB enumeration process, go to the Web site at <http://www.usb.org/developers/>.

Voltage for USB connectors

Table 8 describes the pins and provides an example of the USB cable connector on the display end of a VFD cable.

Table 8. USB power and voltage – VFD display connectors

Pin	dc voltage
1	4.5 to 5.5 V
2, 3	Data
4, 5	Ground
6	10.8 to 13.2 V

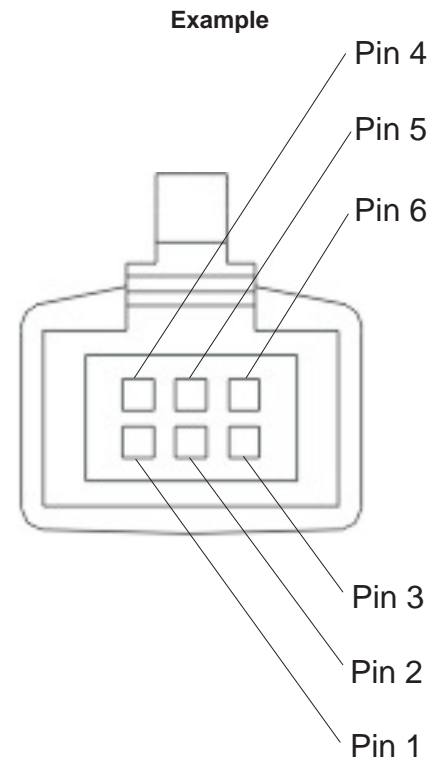
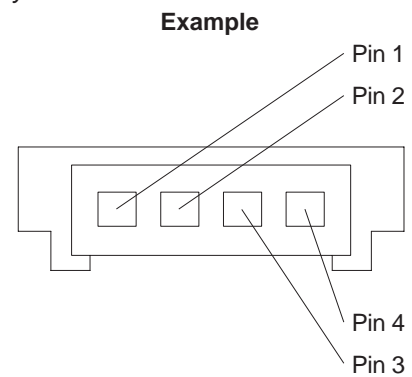

Table 9 describes the pins and provides an example of the USB cable connector on the device end of a keyboard or LCD cable.

Table 9. USB power and voltage – LCD display and keyboard connectors

Pin	dc voltage
1	4.5 to 5.5 V
2	Data
3	Data
4	Ground



Appendix B. Notices

This information was developed for products and services offered in the U.S.A.

IBM may not offer the products, services, or features discussed in this document in other countries. Consult your local IBM representative for information on the products and services currently available in your area. Any reference to an IBM product, program, or service is not intended to state or imply that only that IBM product, program, or service may be used. Any functionally equivalent product, program, or service that does not infringe any IBM intellectual property right may be used instead. However, it is the user's responsibility to evaluate and verify the operation of any non-IBM product, program, or service.

IBM may have patents or pending patent applications covering the subject matter in this document. The furnishing of this document does not give you any license to these patents. You can send license inquiries, in writing, to:

IBM Director of Licensing
IBM Corporation
North Castle Drive
Armonk, NY 10504-1785
U.S.A.

For license inquiries regarding double-byte character set (DBCS) information, contact the IBM Intellectual Property Department in your country or send inquiries, in writing, to:

IBM World Trade Asia Corporation
Licensing
2-31 Roppongi 3-chome, Minato-ku
Tokyo 106, Japan

The following paragraph does not apply to the United Kingdom or any other country where such provisions are inconsistent with local law: INTERNATIONAL BUSINESS MACHINES CORPORATION PROVIDES THIS PUBLICATION "AS IS" WITHOUT WARRANTY OF ANY KIND, EITHER EXPRESS OR IMPLIED, INCLUDING, BUT NOT LIMITED TO, THE IMPLIED WARRANTIES OF NON-INFRINGEMENT, MERCHANTABILITY, OR FITNESS FOR A PARTICULAR PURPOSE. Some states do not allow disclaimer of express or implied warranties in certain transactions, therefore, this statement may not apply to you.

This information could include technical inaccuracies or typographical errors. Changes are periodically made to the information herein; these changes will be incorporated in new editions of the publication. IBM may make improvements and/or changes in the product(s) and/or program(s) described in this publication at any time without notice.

IBM may use or distribute any of the information you supply in any way it believes appropriate without incurring any obligation to you.

Any references in this information to non-IBM Web sites are provided for convenience only and do not in any manner serve as an endorsement of those Web sites. The materials at those Web sites are not part of the materials for this IBM product and use of those Web sites is at your own risk.

Information concerning non-IBM products was obtained from the suppliers of those products, their published announcements or other publicly available sources. IBM has not tested those products and cannot confirm the accuracy of performance, compatibility or any other claims related to non-IBM products. Questions on the capabilities of non-IBM products should be addressed to the suppliers of those products.

This information is for planning purposes only. The information herein is subject to change before the products described become available.

Electronic emission notices

Federal Communications Commission (FCC) statement

This equipment has been tested and found to comply with the limits for a Class A digital device, pursuant to Part 15 of the FCC Rules. These limits are designed to provide reasonable protection against harmful interference when the equipment is operated in a commercial environment. This equipment generates, uses, and can radiate radio frequency energy and, if not installed and used in accordance with the instruction manual, may cause harmful interference to radio communications. Operation of this equipment in a residential area is likely to cause harmful interference, in which case the user will be required to correct the interference at his own expense.

Properly shielded and grounded cables and connectors must be used in order to meet FCC emission limits. IBM is not responsible for any radio or television interference caused by using other than recommended cables and connectors or by unauthorized changes or modifications to this equipment. Unauthorized changes or modifications could void the user's authority to operate the equipment.

This device complies with part 15 of the FCC Rules. Operation is subject to the following two conditions:

1. This device may not cause harmful interference, and
2. This device must accept any interference received, including interference that may cause undesired operation.

Industry Canada Class A Emission Compliance statement

This Class A digital apparatus complies with Canadian ICES-003.

Avis de conformité aux normes d'Industrie Canada

Cet appareil numérique de la classe A est conforme à la norme NMB-003 du Canada.

European Union (EU) Mark of Conformity statement

This product has been tested and found to comply with the limits for Class A Information Technology Equipment according to European Standard EN 55022. The limits for Class A equipment were derived for commercial and industrial environments to provide reasonable protection against interference with licensed communication equipment.

Attention: This is a Class A product. In a domestic environment this product may cause radio interference in which case the user may be required to take adequate measures.

Properly shielded and grounded cables and connectors must be used in order to reduce the potential for causing interference to radio and TV communications and to other electrical or electronic equipment. Such cables and connectors are available from IBM authorized dealers. IBM cannot accept responsibility for any interference caused by using other than recommended cables and connectors.

Germany

Zulassungsbescheinigung laut dem Deutschen Gesetz über die elektromagnetische Verträglichkeit von Geräten (EMVG) vom 30. August 1995 (bzw. der EMC EG Richtlinie 89/336).

Dieses Gerät ist berechtigt in Übereinstimmung mit dem Deutschen EMVG das EG-Konformitätszeichen - CE - zu führen.

Verantwortlich für die Konformitätserklärung nach Paragraph 5 des EMVG ist die IBM Deutschland Informationssysteme GmbH, 70548 Stuttgart

Informationen in Hinsicht EMVG Paragraph 3 Abs. (2) 2:

Das Gerät erfüllt die Schutzanforderungen nach EN 50082–1 und EN 55022 Klasse A.
--

EN 55022 Klasse A Geräte müssen mit folgendem Warnhinweis versehen werden:

"Warnung: dies ist eine Einrichtung der Klasse A. Diese Einrichtung kann im Wohnbereich Funkstörungen verursachen; in diesem Fall kann vom Betreiber verlangt werden, angemessene Maßnahmen durchzuführen und dafür aufzukommen."

EN 50082–1 Hinweis:

"Wird dieses Gerät in einer industriellen Umgebung betrieben (wie in EN 50082–2 festgelegt), dann kann es dabei eventuell gestört werden. In solch einem Fall ist der Abstand bzw. die Abschirmung zu der industriellen Störquelle zu vergrößern."

Anmerkung:

Um die Einhaltung des EMVG sicherzustellen sind die Geräte, wie in den IBM Handbüchern angegeben, zu installieren und zu betreiben.

Australia and New Zealand

Attention: This is a Class A product. In a domestic environment this product may cause radio interference, in which case the user may be required to take adequate measures.

Chinese Class A warning statement

Attention: This is a Class A product. In a domestic environment this product may cause radio interference in which case the user may be required to take adequate measures.

中华人民共和国“A类”警告声明

声 明

此为 A 级产品，在生活环境中，该产品可能会造成无线电干扰。在这种情况下，可能需要用户对其干扰采取切实可行的措施。

Japanese power line harmonics compliance statement

高調波ガイドライン適合品

高調波ガイドライン適合品

Japanese Voluntary Control Council for Interference (VCCI) statement

Attention: This product is a Class A Information Technology Equipment and conforms to the standards set by the Voluntary Control Council for Interference by Technology Equipment (VCCI). In a domestic environment this product may cause radio interference in which case the user may be required to take adequate measures.

この装置は、情報処理装置等電波障害自主規制協議会（VCCI）の基準に基づくクラスA情報技術装置です。この装置を家庭環境で使用すると電波妨害を引き起こすことがあります。この場合には使用者が適切な対策を講ずるよう要求されることがあります。

Korean communications statement

Please note that this device has been approved for business purposes with regard to electromagnetic interference. If you find this is not suitable for your use, you may exchange it for a non-business purpose one.

A급 기기(업무용)

이 기기는 업무용으로 전자파적합등록을 받은 기기이오니 판매자 또는 이용자는 이점을 주의하시기 바라며, 만약 구입하였을 때에는 구입한 곳에서 가정용으로 교환하시기 바랍니다.

Taiwanese Class A warning statement

警告使用者：
這是甲類的資訊產品，在
居住的環境中使用時，可
能會造成射頻干擾，在這
種情況下，使用者會被要
求採取某些適當的對策。

Taiwan contact information

台灣IBM 產品服務聯絡方式：
台灣國際商業機器股份有限公司
台北市松仁路7號3樓
電話：0800-016-888

IBM Taiwan Product Service Contact Info:
IBM Taiwan Corporation
3F, No 7, Song Ren Road, Taipei Taiwan
Telephone: 0800-016-888

Taiwanese battery recycling statement

Waste batteries, please recycle.

 廢電池請回收

Cable ferrite requirement

All cable ferrites are required to suppress radiated EMI emissions and must not be removed.

Electrostatic Discharge (ESD)

Attention: ESD damage can occur when there is a difference in charge between the part, the product, and the service person. No damage will occur if the service person and the part being installed are at the same charge level.

ESD Damage Prevention

Anytime a service action involves physical contact with logic cards, modules, back-panel pins, or other ESD sensitive (ESDS) parts, the service person must be connected to an ESD common ground point on the product through the ESD wrist strap and cord.

The ESD ground clip can be attached to any frame ground, ground braid, green wire ground, or the round ground prong on the AC power plug. Coax or connector outside shells can also be used.

Handling Removed Cards

Logic cards removed from a product should be placed in ESD protective containers. No other object should be allowed inside the ESD container with the logic card. Attach tags or reports that must accompany the card to the outside of the container.

End of life disposal

This unit must be recycled or discarded according to applicable local and national regulations. IBM encourages owners of information technology (IT) equipment to responsibly recycle their equipment when it is no longer needed. IBM offers a variety of product return programs and services in several countries to assist equipment owners in recycling their IT products. Information on IBM product recycling offerings can be found on IBM's Internet site at <http://www.ibm.com/ibm/environment/products/prp.shtml>.



Notice: This mark applies only to countries within the European Union (EU) and Norway.

Appliances are labeled in accordance with European Directive 2002/96/EC concerning waste electrical and electronic equipment (WEEE). The Directive determines the framework for the return and recycling of used appliances as applicable throughout the European Union. This label is applied to various products to indicate that the product is not to be thrown away, but rather reclaimed upon end of life per this Directive.

In accordance with the European WEEE Directive, electrical and electronic equipment (EEE) is to be collected separately and to be reused, recycled, or recovered at end of life. Users of EEE with the WEEE marking per Annex IV of the WEEE Directive, as shown above, must not dispose of end of life EEE as unsorted municipal waste, but use the collection framework available to customers for the return, recycling, and recovery of WEEE. Customer participation is important to minimize any potential effects of EEE on the environment and human health due to the potential presence of hazardous substances in EEE. For proper collection and treatment, contact your local IBM representative.

Disposal of IT products should be in accordance with local ordinances and regulations.

Trademarks

The following are trademarks of International Business Machines Corporation in the United States or other countries, or both:

IBM and the IBM logo
PS/2
SureMark
SurePoint
SurePOS
Wake on LAN

Microsoft, Windows, Windows NT, and the Windows logo are trademarks of Microsoft Corporation in the United States, other countries, or both.

Celeron and Intel are trademarks of Intel corporation in the United States, or other countries.

Java and all Java-based trademarks and logos are trademarks or registered trademarks of Sun Microsystems, Inc. in the United States, or other countries, or both.

Other company, product, or service names may be trademarks or service marks of others.

Appendix C. Safety information



Danger:

Before you begin to install this product, read the safety information in *IBM Safety Information — Read This First*, GA27-4004. This booklet describes safe procedures for cabling and plugging in electrical equipment.



Gevaar:

Voordat u begint met de installatie van dit product, moet u eerst de veiligheidsinstructies lezen in de brochure *Veiligheidsinstructies—Lees dit eerst*, GA27-4004. Hierin wordt beschreven hoe u elektrische apparatuur op een veilige manier moet bekabelen en aansluiten.



Perigo:

Antes de começar a instalar este produto, leia as informações de segurança contidas em *Informações Sobre Segurança—Leia Isto Primeiro*, GA27-4004. Esse folheto descreve procedimentos de segurança para a instalação de cabos e conexões em equipamentos elétricos.



Fare!

Før du installerer dette produkt, skal du læse sikkerhedsforskrifterne i *Sikkerhedsforskrifter—Læs dette først* GA27-4004. Vejledningen beskriver den fremgangsmåde, du skal bruge ved tilslutning af kabler og udstyr.



Gevaar

Voordat u begint met het installeren van dit produkt, dient u eerst de veiligheidsrichtlijnen te lezen die zijn vermeld in de publikatie *IBM Safety Information — Read This First*, GA27-4004. In dit boekje vindt u veilige procedures voor het aansluiten van elektrische apparatuur.



VAARA

Ennen kuin aloitat tämän tuotteen asennuksen, lue julkaisussa *Turvaohjeet—Luetämä ensin*, GA27-4004, olevat turvaohjeet. Tässä kirjasessa on ohjeet siitä, miten sähkölaitteet kaapeloidaan ja kytketään turvallisesti.



Danger

Avant d'installer le présent produit, consultez le livret *Informations pour la sécurité—Lisez-moi d'abord*, GA27-4004, qui décrit les procédures à respecter pour effectuer les opérations de câblage et brancher les équipements électriques en toute sécurité.



Vorsicht

Bevor mit der Installation des Produktes begonnen wird, die Sicherheitshinweise in *Sicherheitsinformationen—Bitte zuerst lesen*, IBM Form GA27-4004. Diese Veröffentlichung beschreibt die Sicherheitsvorkehrungen für das Verkabeln und Anschließen elektrischer Geräte.



Vigyázat

Mielőtt megkezdi a berendezés üzembe helyezését, olvassa el a *IBM Safety Information — Read This First*, GA27-4004 könyvecskében leírt biztonsági információkat. Ez a könyv leírja, milyen biztonsági intézkedéseket kell megtenni az elektromos berendezés húzalozásakor illetve csatlakoztatásakor.



Pericolo

prima di iniziare l'installazione di questo prodotto, leggere le informazioni relative alla sicurezza riportate nell'opuscolo *Informazioni di sicurezza—Prime informazioni da leggere* in cui sono descritte le procedure per il cablaggio ed il collegamento di apparecchiature elettriche.



Fare

Før du begynner å installere dette produktet, må du lese sikkerhetsinformasjonen i *Sikkerhetsinformasjon—Les dette først*, GA27-4004 som beskriver sikkerhetsrutinene for kabling og tilkobling av elektrisk utstyr.



Perigo

Antes de iniciar a instalação deste produto, leia as informações de segurança *Informações de Segurança—Leia Primeiro*, GA27-4004. Este documento descreve como efectuar, de um modo seguro, as ligações eléctricas dos equipamentos.



Peligro

Antes de empezar a instalar este producto, lea la información de seguridad en *Información de Seguridad—Lea Esto Primero, GA27-4004*. Este documento describe los procedimientos de seguridad para cablear y enchufar equipos eléctricos.



Varning—livsfara

Innan du börjar installera den här produkten bör du läsa säkerhetsinformationen i dokumentet *Säkerhetsföreskrifter—Läs detta först, GA27-4004*. Där beskrivs hur du på ett säkert sätt ansluter elektrisk utrustning.

危險：安裝本產品之前，請先閱讀
"IBM Safety Information--Read
This First" GA27-4004 手冊中所提
供的安全注意事項。這本手冊將會說明
使用電器設備的纜線及電源的安全程序。

Opasnost: Prije nego sto počnete sa instalacijom produkta,
pročitajte naputak o pravilima o sigurnom rukovanju u
Upozorenje: Pravila o sigurnom rukovanju - Prvo pročitaj ovo,
GA27-4004. Ovaj privitak opisuje sigurnosne postupke za
priključivanje kabela i priključivanje na električno napajanje.

Upozornění: než zahájíte instalaci tohoto produktu, přečtěte si
nejprve bezpečnostní informace v pokynech „Bezpečnostní
informace“ č. GA27-4004. Tato brožurka popisuje bezpečnostní
opatření pro kabeláž a zapojení elektrického zařízení.

Κίνδυνος: Πριν ξεκινήσετε την εγκατάσταση αυτού του προϊόντος,
διαβάστε τις πληροφορίες ασφάλειας στο φυλλάδιο *IBM Safety
Information-Read this first, GA27-4004*. Στο φυλλάδιο αυτό
περιγράφονται οι ασφαλείς διαδικασίες για την καλωδίωση των
ηλεκτρικών συσκευών και τη σύνδεσή τους στην πρίζα.

危險：導入作業を開始する前に、安全に関する
小冊子 GA27-4004 の「最初にお読みください」
(Read This First) の項をお読みください。
この小冊子は、電気機器の安全な配線と接続の
手順について説明しています。

위험: 이 제품을 설치하기 전에 반드시
"주의: 안전 정보-시작하기 전에"
(GA27-4004) 에 있는 안전 정보를
읽으십시오.

סכנה : לפני שמתחילים בהתקנת מוצר זה, יש לקרוא את הוראות הבטיחות בחוברת
Caution: Safety Information - Read This First, GA27-4004
חוברת זו מתארת את הוראות הבטיחות לחיבור הכבלים ולחיבור לחשמל של ציוד חשמלי.

خطر: قبل عملية بدء تركيب هذا المنتج، قم بقراءة معلومات
الحمية الموجودة في التحذير: معلومات الحماية - Read This First
GA27-4004 . يقوم هذا الكتيب بوصف اجراءات الأمان
لتوصيل الأدوات الكهربائية بالكابلات والمقبس الكهربائي.

ОПАСНОСТ

Пред да почнете да го инсталирате овој продукт, прочитајте ја информацијата за безбедност:
"Предупредување: Информација за безбедност: Прочитајте го прво ова", GA27-4004.
Оваа брошура опишува безбедносни процедури за каблирање и вклучување на електрична опрема.

Uwaga:

Przed rozpoczęciem instalacji produktu należy zapoznać się z instrukcją: "IBM Safety Information - Read This First", GA27-4004.
Zawiera ona warunki bezpieczeństwa przy podłączaniu do sieci elektrycznej i eksploatacji.

ОСТОРОЖНО: Прежде чем устанавливать этот продукт, прочтите Инструкцию по технике безопасности в документе "Внимание: Инструкция по технике безопасности -- Прочестъ в первую очередь", GA27-4004. В этой брошюре описаны безопасные способы каблирования и подключения электрического оборудования.

Nebezpečenstvo: Pred inštaláciou výrobku si prečítajte bezpečnosté predpisy v
Výstraha: Bezpečnosté predpisy - Prečítaj ako prvé, GA27-4004. V tejto brožúrke sú opísané bezpečnosté postupy pre pripojenie elektrických zariadení.

Pozor: Preden začnete z instalacijo tega produkta preberite poglavje: "Opozorilo: Informacije o varnem rokovanju-preberi pred uporabo," GA27-4004. To poglavje opisuje pravilne postopke za kabliranje,

危險：

開始安裝此產品之前，請先閱讀安全資訊。

注意：

請先閱讀 - 安全資訊 GA27-4004

此冊子說明插接電器設備之電纜線的安全程序。

危險：

在开始安装本产品之前，请阅读
IBM Safety Information - Read This First,
GA27-4004 中的安全信息。
此手册描述了如何安全地连接和插拔电气设备。

Glossary

This glossary includes terms and definitions from:

- *American National Standard Dictionary for Information Systems*, ANSI X3.172-1990, copyright 1990 by the American National Standards Institute (ANSI). Copies may be purchased from the American National Standards Institute, 11 West 42nd Street, New York, New York 10036. Definitions are identified by the symbol (A) after the definition.
- The *Information Technology Vocabulary*, developed by Subcommittee 1, Joint Technical Committee 1, of the International Organization for Standardization and the International Electrotechnical Commission (ISO/IEC JTC1/SC1). Definitions of published parts of this vocabulary are identified by the symbol (I) after the definition; definitions taken from draft international standards, committee drafts, and working papers being developed by ISO/IEC JTC1/SC1 are identified by the symbol (T) after the definition, indicating that final agreement has not yet been reached among the participating National Bodies of SC1.

A

active. (1) Able to communicate on the network. A token-ring network adapter is active if it is able to transmit and receive on the network (2) Operational. (3) Pertaining to a node or device that is connected or is available for connection to another node or device. (4) Currently transmitting or receiving.

adapter. (1) In the point-of-sale terminal, a circuit card that, with its associated software, enables the terminal to use a function or feature. (2) In a LAN, within a communicating device, a circuit card that, with its associated software and/or microcode, enables the device to communicate over the network.

address. (1) In data communication, the IEEE-assigned unique code or the unique locally administered code assigned to each device or workstation connected to a network. (2) A character or group of characters that identifies a register, a particular part of storage, or some other data source or destination. (A) (3) To refer to a device or an item of data by its address. (I) (A) (4) The location in the storage of a computer where data is stored.

addressing. (1) The assignment of addresses to the instructions of a program. (2) In data communication, the way in which a station selects the station to which it is to send data.

alphanumeric. Pertaining to data consisting of letters, digits, and usually other characters, such as punctuation marks. (T) (A)

analog. (1) Pertaining to data consisting of continuously variable physical quantities. (A) (2) Contrast with *digital*.

application. (1) A collection of one or more programs that work together to accomplish goals for a business. (2) A set of executable files and data files required to perform a desired function, which can consist of multiple programs running on different workstations.

architecture. A logical structure that encompasses operating principles including services, functions, and protocols. See *network architecture*.

attach. (1) To connect a device physically. (2) To make a device a part of a network logically. Compare with *connect*.

attaching device. Any device that is physically connected to a network and can communicate over the network.

B

bit. Either of the digits 0 or 1 when used in the binary numeration system. Synonymous with binary digit. (T)

bus. (1) In a processor, a physical facility on which data is transferred to all destinations, but from which only addressed destinations may read in accordance with appropriate conventions. (2) A network configuration in which nodes are interconnected through a bidirectional transmission medium. (3) One or more conductors used for transmitting signals or power. (A)

C

cash drawer. An optional I/O device attached to a point-of-sale terminal. The cash drawer contains a till. The cash drawer will open upon receiving a command. See *till*.

circuit. (1) A logic device. (2) One or more conductors through which an electric current can flow.

cluster. (1) A station that consists of a control unit (a cluster controller) and the terminals attached to it. (2) A group of APPN nodes that have the same network ID and the same topology database. A cluster is a subset of a NETID subnetwork. (3) In high-availability cluster multiprocessing (HACMP), a set of independent systems (called nodes) that are organized into a network for the purpose of sharing resources and communicating with each other.

collision. (1) An unwanted condition that results from concurrent transmissions on a channel. (T) (2) When a frame from a transmitting adapter encounters any other signal in its path (frame, noise, or another type of signal), the adapter stops transmitting and a collision is registered.

command. (1) A request for performance of an operation or execution of a program. (2) A character string from a source external to a system that represents a request for system action.

component. (1) Any part of a network other than an attaching device, such as an IBM 8228 Multistation Access Unit. (2) Hardware or software that is part of a functional unit.

configuration. (1) The devices and programs that make up a system, subsystem, or network. (A) See also *system configuration*. (2) In the IBM StorePlace Distributed Data Services for OS/2, program options that are initially set at installation, and that can be changed later. Changing these options requires an IPL. These changes must be performed by a programmer or store operations personnel. These options are used to tune the product's use of the operating system and machine resources.

connect. In a LAN, to physically join a cable from a station to an access unit or network connection point. Contrast with *attach*.

controller. A unit that controls input/output operations for one or more devices.

cursor. A movable point of light (or a short line) that indicates where the next character is to be entered on the display screen.

D

data. (1) A representation of facts, concepts, or instructions in a formalized manner suitable for communication, interpretation, or processing by human or automatic means. (I) (A) (2) Any representations such as characters or analog quantities to which meaning is or might be assigned. (A)

data file. A collection of related data records organized in a specific manner; for example, a payroll file (one record for each employee, showing such information as rate of pay and deductions) or an inventory file (one record for each inventory item, showing such information as cost, selling price, and number in stock.) See also *data set, file*.

data processing system. A system, including computer systems and associated personnel, that performs input, processing, storage, output, and control functions to accomplish a sequence of operations on data. (A) (I)

data set. Logically related records treated as a single unit. See also *file*.

DBCS. See *double-byte character set*.

device. (1) A mechanical, electrical, or electronic contrivance with a specific purpose. (2) An input/output unit such as a terminal, display, or printer. See also *attaching device*.

diagnostic diskette. A diskette containing diagnostic modules or tests used by computer users and service personnel to diagnose hardware problems.

diagnostics. Modules or tests used by computer users and service personnel to diagnose hardware problems.

digital. (1) Pertaining to data in the form of digits. (A) Contrast with *analog*. (2) Pertaining to data consisting of numerical values or discrete units.

DIP switch. A two-position switch on a circuit board that is preset to control certain functions. The user can change the position of a DIP switch to satisfy special requirements.

disk. A round, flat, data medium that is rotated in order to read or write data. (T) See also *diskette, hard-disk drive*.

disk operating system (DOS). A computer operating system that can perform only one task at a time.

diskette. A thin, flexible magnetic disk permanently enclosed in a protective jacket. A diskette is used to store information for processing.

diskette drive. The mechanism used to seek, read, and write data on diskettes.

display. (1) A visual presentation of data. (2) A device that presents visual information to the point-of-sale terminal operator and to the customer.

distributed. Physically separate but connected by cables.

DOS. See *disk operating system*.

double-byte character set (DBCS). A set of characters in which each character is represented by 2 bytes. Languages such as Japanese, Chinese, and Korean, which contain more symbols than can be represented by 256 code points, require double-byte character sets. Because each character requires 2 bytes, the typing, display, and printing of DBCS characters requires hardware and programs that support DBCS. Contrast with *single-byte character set*.

DRAM. Dynamic RAM. See *RAM*.

driver. A software component that controls a device.

dump. (1) To record, at a particular instant, the contents of all or part of one storage device in another storage device. Dumping is usually for the purpose of debugging. (T) (2) Data that has been dumped. (T)

DVD-ROM. Digital-video-disk read-only memory.

E

error message. A message that is issued because an error has been detected.

F

FCC. See *Federal Communications Commission*.

feature. A part of an IBM product that may be ordered separately by the customer.

Federal Communications Commission (FCC). A board of commissioners appointed by the President under the Communications Act of 1934, having the power to regulate all interstate and foreign communications by wire and radio originating in the United States.

field. On a data medium or a storage medium, a specified area used for a particular category of data; for example, a group of character positions used to enter or display wage rates on a panel. (T)

file. A named set of records stored or processed as a unit. (T) For example, an invoice may form a record and the complete set of such records may form a file. See also *data set*.

flash memory. A data-storage device that is programmable, erasable, and does not require continuous power. The chief benefit of flash memory over other programmable and erasable data storage devices is that it can be reprogrammed without being removed from the circuit board.

formatted diskette. A diskette on which track and sector control information has been written and that can be used by the computer to store data. **Note:** A diskette must be formatted before it can receive data.

frame . (1) The unit of transmission in some LANs, including the IBM Token-Ring Network and the IBM PC Network. It includes delimiters, control characters, information, and checking characters. On a token-ring network, a frame is created from a token when the token has data appended to it. On a token-bus network (IBM PC Network), all frames including the token frame contain a preamble, start delimiter, control address, optional data and checking characters, end delimiter, and are followed by a minimum silence period. (2) A housing for machine elements. (3) In synchronous data link control (SDLC), the vehicle for every command,

every response, and all information that is transmitted using SDLC procedures. Each frame begins and ends with a flag.

function. (1) A specific purpose of an entity, or its characteristic action. (A) (2) In data communications, a machine action such as a carriage return or line feed. (A)

H

hard-disk drive. In a personal computer system unit, a disk storage device that reads and writes on rigid magnetic disks. It is faster and has a larger storage capacity than a diskette and is permanently installed. Synonymous with *fixed disk*.

HID. See *human interface devices*.

hot pluggable. Refers to a hardware component that can be installed or removed without disturbing the operation of any other resource that is not connected to, or dependent on, this component.

human interface devices (HID). Devices which allow humans to interact and communicate with a computer. Examples are a keyboard or a mouse.

hot plugging. Process of installing connections to the serial bus while the system is running and without powering down.

hot unplugging. Process of removing connections from the serial bus while the system is running and without powering down.

hypertext. (1) A method of presenting text in discrete units, or nodes, that are connected by links for navigation. (2) Text designed to be read or accessed in a nonlinear manner using nodes that are connected by links for navigation.

I

I/O. See *input/output*.

I/O device. A device in a data processing system by means of which data can be entered into the system, received from the system, or both. (I) (A)

IBM Disk Operating System (DOS) . A disk operating system based on MS-DOS that operates with all IBM-compatible personal computers.

IEEE. Institute of Electrical and Electronics Engineers.

input/output (I/O). (1) Pertaining to a device whose parts can perform an input process and an output process at the same time. (I) (2) Pertaining to a functional unit or channel involved in an input process, output process, or both, concurrently or not, and to the data involved in such a process.

integrated. Arranged together as one unit.

interference. (1) The prevention of clear reception of broadcast signals. (2) The distorted portion of a received signal.

interrupt. (1) A suspension of a process, such as execution of a computer program, caused by an external event and performed in such a way that the process can be resumed. (A) (2) To stop a process in such a way that it can be resumed. (3) A means of passing processing control from one software or microcode module or routine to another, or of requesting a particular software, microcode, or hardware function.

J

jabber. Transmission by a data station beyond the time interval allowed by the protocol. (T)

K

K. When referring to storage capacity, a symbol that represents two to the tenth power, or 1024.

keyboard. A group of numeric keys, alphabetic keys, special character keys, or function keys used for entering information into the terminal and into the system.

L

LAN. See *local area network*.

LAN adapter. The circuit card within a communicating device (such as a personal computer) that, together with its associated software, enables the device to be attached to a LAN.

LED. Light-emitting diode.

light-emitting diode (LED). A semiconductor chip that gives off visible or infrared light when activated.

line. On a terminal, one or more characters entered before a return to the first printing or display position.

link. (1) The logical connection between nodes including the end-to-end link control procedures. (2) The combination of physical media, protocols, and programming that connects devices on a network. (3) In computer programming, the part of a program, in some cases a single instruction or an address, that passes control and parameters between separate portions of the computer program. (4) To interconnect items of data or portions of one or more computer programs. (5) In SNA, the combination of the link connection and link stations joining network nodes. See also *link connection*. **Note:** A link connection is the physical medium of transmission; for example, a telephone wire or a microwave beam. A link includes the physical

medium of transmission, the protocol, and associated devices and programming; it is both logical and physical.

link connection. (1) All physical components and protocol machines that lie between the communicating link stations of a link. The link connection may include a switched or leased physical data circuit, a LAN, or an X.25 virtual circuit. (2) In SNA, the physical equipment providing two-way communication and error correction and detection between one link station and one or more other link stations. (3) In the IBM Store System, the logical link providing two-way communication of data from one network node to one or more other network nodes.

load. In computer programming, to enter data into memory or working registers.

local area network (LAN). A computer network located on a user's premises within a limited geographical area. **Note:** Communication within a LAN is not subject to external regulations; however, communication across the LAN boundary may be subject to some form of regulation.

logon. The procedure for starting up a point-of-sale terminal or store controller for normal sales operations by sequentially entering the correct security number and transaction number. Synonymous with *sign-on*.

M

magnetic ink character reader (MICR). An input unit that reads characters by magnetic ink character recognition. (A)

magnetic ink character recognition. (1) MICR. Character recognition of magnetic ink characters. (T) (2) The identification of characters through the use of magnetic ink.

MB. See *megabyte*.

Mbps. One million bits per second.

megabyte (MB). A unit of measure for data. 1 megabyte = 1 048 576 bytes.

memory. Program-addressable storage from which instructions and other data can be loaded directly into registers for subsequent execution or processing.

message. (1) An arbitrary amount of information whose beginning and end are defined or implied. (2) A group of characters and control bit sequences transferred as an entity. (3) In telecommunication, a combination of characters and symbols transmitted from one point to another. (4) A logical partition of the user device's data stream to and from the adapter. See also *error message*, *operator message*.

MICR. See magnetic ink character reader and magnetic ink character recognition.

module. A program unit that is discrete and identifiable with respect to compiling, combining with other units, and load; for example, the input to, or output from, an assembler, compiler, linkage editor, or executive routine.

N

network. (1) A configuration of data processing devices and software connected for information interchange. (2) An arrangement of nodes and connecting branches. Connections are made between data stations.

network architecture. The logical structure and operating principles of a computer network. **Note:** The operating principles of a network include those of services, functions, and protocols.

noise. (1) A disturbance that affects a signal and that can distort the information carried by the signal. (2) Random variations of one or more characteristics of any entity, such as voltage, current, or data. (3) Loosely, any disturbance tending to interfere with normal operation of a device or system.

nonvolatile random access memory (NVRAM) . Random access memory that retains its contents after electrical power is shut off. Contrast with *volatile memory*.

NVRAM. See nonvolatile random access memory.

O

operating system. Software that controls the execution of programs and that may provide services such as resource allocation, scheduling, input/output control, and data management. Although operating systems are predominantly software, partial hardware implementations are possible. (T)

Operating System/2® (OS/2®). A set of programs that control the operation of high-speed large-memory IBM Personal Computers providing multitasking. Contrast with *Disk Operating System (DOS)*.

operator. A person who operates a machine.

operator message. A message from the operating system or a program telling the operator to perform a specific function or informing the operator of a specific condition within the system, such as an error condition.

option. (1) A specification in a statement, a selection from a menu, or a setting of a switch, that can be used to influence the execution of a program. (2) A hardware or software function that can be selected or enabled as part of a configuration process. (3) A piece of hardware

(such as a network adapter) that can be installed in a device to modify or enhance device function.

OS. Operating system.

OS/2. Operating System/2.

P

page. The information displayed at the same time on the screen of a display device.

panel. (1) A thin flat sheet, usually (a) of pressed metal and carrying controls and indicators, (b) of glass, or (c) of plastic. (2) A formatted display of information that appears on a display screen.

parallel port. A port that transmits the bits of a byte in parallel along the lines of the bus, one byte at a time, to an I/O device. On a personal computer, it is used to connect a device that uses a parallel interface, such as a dot matrix printer, to the computer. Contrast with *serial port*.

PC. See *personal computer*.

personal computer (PC). A desk-top, free-standing, or portable microcomputer that usually consists of a system unit, a display, a keyboard, one or more diskette drives, internal fixed-disk storage, and an optional printer. PCs are designed primarily to give independent computing power to a single user and are inexpensively priced for purchase by individuals or small businesses. Examples include the various models of the IBM Personal Computers.

plug. (1) A connector for attaching wires from a device to a cable, such as a store loop. A plug is inserted into a receptacle or plug. (2) To insert a connector into a receptacle or socket.

Plug and Play (PnP). Pertaining to the capability of a hardware or software component to be installed on a system with minimal effort and to be available for use immediately thereafter.

PnP. See *Plug and Play*.

point-of-sale (POS). A method of providing information to support sales and of collecting the resulting sales information from retail devices located in stores.

port. (1) An access point for data entry or exit. (2) A connector on a device to which cables for other devices such as display stations and printers are attached. Synonymous with *socket*.

POS. See *point-of-sale*.

POST . Power-on self-test.

power-on self-test (POST) . A series of diagnostic tests that are run automatically each time the computer's power is switched on.

problem determination. The process of determining the source of a problem; for example, a program component, machine failure, telecommunication facilities, user or contractor-installed programs or equipment, environmental failure such as a power loss, or user error.

procedure. (1) A set of related control statements that cause one or more programs to be performed. (2) A set of instructions that gives a service representative a step-by-step procedure for tracing a symptom to the cause of failure.

processor. In a computer, a functional unit that interprets and executes instructions. (A) (I)

protocol. (1) A set of semantic and syntactic rules that determine the behavior of functional units in achieving communication. (I) (2) A specification for the format and relative timing of information exchanged between communicating parties.

R

RAM. See *random access memory*.

random access memory (RAM). A computer's or adapter's volatile memory, which can be accessed nonsequentially.

read. To acquire or to interpret data from a storage device, from a data medium, or from another source. (I) (A)

real-time. (1) Pertaining to the actual time during which a physical process occurs. (2) Pertaining to data collected concurrently with physical events, so that the results of the collection operation may be used to influence the sequence of events.

receive. To obtain and store information transmitted from a device.

record. A collection of related items of data, treated as a unit; for example, in stock control, each invoice could constitute one record. A complete set of such records may form a file.

repeater. A device that amplifies or regenerates data signals in order to extend the range of transmission between devices in a network.

S

SBCS. See *single-byte character set*.

scanner. A device that examines the bar code on merchandise tickets, credit cards, and employee badges and generates analog or digital signals corresponding to the bar code.

serial port. On personal computers, a port used to attach devices such as display devices, letter-quality printers, modems, plotters, and pointing devices such as light pens and mice; it transmits data one bit at a time. Contrast with *parallel port*.

signal. A variation of a physical attribute, used to convey data. (A)

single-byte character set (SBCS). Single-byte character set. A character set in which each character is represented by a one-byte code. Contrast with *double-byte character set*.

socket. (1) An opening that holds something. (2) Synonym for *port*.

source. The origin of any data involved in a data transfer.

subsystem. A secondary or subordinate system, usually capable of operating independently of, or asynchronously with, a controlling system. (T)

switch. (1) A device for making and breaking electrical connections, for making a selection, or for requesting a function or operation. (2) On an adapter, a mechanism used to select a value for, enable, or disable a configurable option or feature.

system. (1) In data processing, a collection of people, machines, and methods organized to accomplish a set of specific functions. (I) (A) See also *data processing system*, *operating system*, and *system unit*. (2) In the IBM StorePlace Distributed Data Services for OS/2, a group of nodes for which files are managed.

system board. In a system unit, the main circuit board that supports a variety of basic system devices, such as a keyboard or a mouse, and provides other basic system functions.

system configuration. A process that specifies the devices and programs that form a particular data processing system.

system unit. (1) A part of a computer that contains the processing unit and may contain devices such as disk and diskette drives. (2) In an IBM Personal Computer, the unit that contains the processor circuitry, read-only memory (ROM), random access memory (RAM), and the I/O channel. It may have one or more disk or diskette drives. (3) In an IBM Store System terminal, the part of the terminal that contains the processing unit, ROM, RAM, disk and diskette drives, and the I/O channel.

T

terminal. In data communication, a device, usually equipped with a keyboard and a display, that is capable of sending and receiving information.

till. A tray in the cash drawer of the point-of-sale terminal, used to keep the different denominations of bills and coins separated and easily accessible.

transmit. To send information from one place for reception elsewhere. (A)

twisted pair. A transmission medium that consists of two insulated electrical conductors twisted together. (A)

typematic. The ability of a key on a keyboard to repeatedly type a character as long as it is held down.

U

Universal Serial Bus (USB). A serial interface standard for telephony and multimedia connections to personal computers.

Universal Serial Bus (USB), powered. A powered-USB connector provides additional power from the host system. A powered-USB receptacle consists of two connectors stacked vertically inside the common housing. The upper connector contains four contacts that are used for powering the attached device.

unshielded twisted pair (UTP). One or more twisted pairs of copper wire in the unshielded voice-grade cable commonly used to connect a telephone to its wall jack.

user. (1) A category of identification defined for file access protection. (2) A person using a program or system.

USB. See *Universal Serial Bus*.

V

version . A separately licensed program that usually has significant new code or new function.

vital product data (VPD). Information about the computer, such as machine type and model or serial number, stored in the BIOS.

volatile memory. Memory that loses its contents when power is turned off.

VPD. See *vital product data*.

Index

Numerics

- 40-character LCD, removing and replacing 26
- 40-character vacuum fluorescent display (VFD)
 - lens, cleaning 25
 - removing and replacing 24

A

- advantages of USB 123
- assembly, VFD 60
- attached to counter, CRT post mount 31

B

- blank lock insert, removing and replacing
 - cash drawer, removing and replacing 22
 - keyboard, removing and replacing 53
- bus, universal serial 123

C

- cable ferrite requirement 130
- cash drawer
 - blank lock insert, removing and replacing 22
 - common service procedures 17
 - latch and sensor assembly, removing and replacing 18
 - lock assembly, removing and replacing 20
 - lock insert, removing and replacing 21
 - messages 4
 - removing and replacing coin-roll cutter, compact 16
 - removing and replacing compact 12
 - removing and replacing rollers, compact 15
 - removing and replacing security clip, compact 17
 - removing and replacing slanted I/O tray, full-size 8
 - removing and replacing slide assembly, compact 14
 - removing and replacing slide assembly, full-size 7
 - removing and replacing slide latches, compact 13
 - removing and replacing, full-size 6
 - service procedures for full-size 6
 - symptoms 5
 - top cover, removing and replacing 18
- character graphics display filler 11
- character/graphics display 27
- Class A compliance statement
 - Australia and New Zealand 128
 - China 129
 - European Union 127
 - FCC (USA) 127
 - Germany 127
 - Industry Canada 127
 - Japan 129
 - Taiwan 130
- cleaning VFD lens 25
- coin roll cutter 16
- CRT mounting plate 30
- CRT post mount, counter-attached 31

- CRT table mount 32
- CRTs, service procedures 28

D

- damage from electrostatic discharge 130
- device enumeration 123
- devices
 - standalone testing 2
- diagnostics 1
- display symptoms
 - character/graphics display 23
 - LCD 23
 - VFD 23
- disposal of equipment 131

E

- electronic emissions notices 127
 - Australia and New Zealand 128
 - China 129
 - European Union 127
 - FCC (USA) 127
 - Germany 127
 - Industry Canada 127
 - Japan 129
 - Korea 129
 - Taiwan 130
- electrostatic discharge (ESD) 130
- end of life disposal 131
- enumeration, device 123
- equipment disposal 131

F

- ferrite requirement 130
- filler panels
 - character/graphics display 11
 - installing 8
 - printer 11

I

- IBM publications, related xi
- identification, USB device 123

J

- Japanese power line harmonics compliance statement 129
- Japanese Voluntary Control Council for Interference statement 129

K

- keyboard
 - keypad assembly, replacing 43

keyboard (*continued*)
 logic card, replacing 45
 messages 38
 MSR 46
 MSR control card 47
 service 42
 symptoms 38
 types 36

keyboard (CANPOS) logic card, removing and replacing 45
 keyboard logic card, removing and replacing 52
 keyboard matrix unit, removing and replacing 61
 keylock insert, removing and replacing
 keyboard 53
 keypad assembly, removing and replacing 43, 50
 Korean communications statement 129

L

latch and sensor assembly, removing and replacing 18
 LCD
 40-character, removing and replacing 26
 keyboard, removing and replacing 52
 lock aligner 21
 lock insert, remove and replace 21
 logic board, removing and replacing 62
 logic card, removing and replacing CANPOS
 keyboard 45
 logic card, removing and replacing keyboard 52

M

magnetic stripe reader (MSR)
 keyboard flexible cable, removing and replacing 51
 on keyboard-V, removing and replacing 56
 messages, keyboards 38
 MSR (magnetic stripe reader)
 keyboard flexible cable, removing and replacing 51
 on keyboard-V, removing and replacing 56
 MSR, keyboard, removing and replacing 50

N

notices 125, 133
 battery recycling 130
 cable ferrites 130
 electronic emissions 127
 electrostatic discharge (ESD) 130
 end of life disposal 131
 IBM 125

P

parts catalog 67
 PLU extension box, USB 65
 post-mounted CRT 28
 powered USB connectors 124
 printer filler 11
 problem determination 1

PS/2 ANPOS keyboard with integrated pointing device
 ergonomic considerations 41
 using the joystick 40

R

related publications xi
 removal and replacement procedures
 40-character liquid crystal display (LCD) 26
 blank lock insert, cash drawer 22
 blank lock insert, keyboard 53
 cash blank lock insert 22
 cash drawer latch and sensor assembly 18
 character graphics display filler 11
 character/graphics display 27
 coin-roll cutter, cash drawer, compact 16
 compact cash drawer 12
 compact cash drawer coin-roll cutter 16
 compact cash drawer rollers 15
 compact cash drawer security clip 17
 compact cash drawer slide assembly 14
 compact cash drawer slide latches 13
 control card, CANPOS keyboard 47
 counter-attached CRT post mount 31
 CRT mounting plate 30
 CRT post mount, counter-attached 31
 CRT table mount 32
 CRT, post-mounted 28
 CRT, table-mounted 30
 CRT, wedge-mounted 29
 displays 23
 full-size cash drawer 6
 full-size cash drawer slide assembly 7
 keyboard blank lock insert 53
 keyboard LCD 52
 keyboard lock insert 53
 keyboard logic card 52
 keyboard logic card, CANPOS 45
 keypad assembly 43, 50
 latch and sensor assembly components, cash drawer 19
 latch and sensor assembly, cash drawer 18
 LCD, keyboard 52
 lens, vacuum fluorescent display (VFD) 25
 lock assembly, cash drawer 20
 lock insert 21
 lock insert, keyboard 53
 logic card, CANPOS keyboard 45
 logic card, keyboard 52
 mounting plate, CRT 30
 MSR flexible cable 51
 MSR, CANPOS keyboard 46
 MSR, keyboard 50
 post-mounted CRT 28
 printer filler 11
 removing, CANPOS keyboard 46
 rollers, cash drawer, compact 15
 security clip, cash drawer, compact 17
 slanted I/O tray on wide cash drawer 8
 slide assembly, compact cash drawer 14
 slide assembly, full-size cash drawer 7

last update: March 22, 2007

removal and replacement procedures *(continued)*
slide latches, compact cash drawer 13
table mount, CRT 32
table-mounted CRT 30
top cover, cash drawer 18
USB keyboard-V components
logic board 54
matrix unit 58
MSR 56
opening the cover 54
speaker assembly 57
top cover assembly 59
USB PLU extension box 65
USB PLU keyboard components
bottom cover assembly 64
keyboard matrix unit 61
logic board 62
opening the cover 59
top cover assembly 64
VFD assembly 60
vacuum fluorescent display (VFD), 40-character 24
VFD (vacuum fluorescent display), 40-character 24
VFD lens 25
wedge-mounted CRT 29
wide cash drawer 6

W

wedge-mounted CRT 29

S

safety information 133
security clip, compact cash drawer 17
service procedure
keyboard components 42
symptoms
cash drawer 5
character/graphics display 23
keyboards 38
LCD 23
VFD 23

T

Taiwanese battery recycling statement 130
testing devices 2
tests 1
trademarks 131
troubleshooting the USB PLU extension box 65

U

universal serial bus (USB) 123
USB (universal serial bus) 123
USB advantages 123
USB device identification 123
USB PLU extension box
symptom explanation and cause 65

V

VFD assembly, removing and replacing 60
VFD, removing and replacing 24

Part number index

Part Number	Asm-Index	Page	Part Number	Asm-Index	Page
06P5223	23-	121	16K9075	23-	121
10H3315	3-2	75	20P0276	1-3	71
10H3317	3-9	75	20P0276	3-15	75
10H3318	3-16	75	20P0278	1-4	71
10H3319	3-24	75	20P0279	1-2	71
10H3331	3-19	75	20P0308	21-5	117
10H3340	3-	75	20P0329	3-16	75
10H3340	3-	75	20P0334	5-10	79
10H3341	3-	75	20P0334	5-4	79
10H3341	3-	75	20P0337	5-11	79
10H3355	3-11	75	20P0337	5-5	79
10H3371	3-22	75	20P0338	5-3	79
10H3373	3-14	75	20P0360	5-	79
10H3374	3-17	75	20P0360	5-	79
10H3375	3-7	75	25H4178	2-16	73
10H3379	3-20	75	25H4179	2-16	73
10H3380	3-21	75	25H4183	2-18	73
10H3381	3-23	75	25L5486	5-3	79
10J0584	4-1	77	25L5487	5-3	79
10J0585	4-1	77	25L5488	5-10	79
10N1193	19-5	113	25L5488	5-4	79
10N1248	19-4	113	25L5498	5-	79
10N1253	19-3	113	25L5498	5-	79
10N1259	19-6	113	25L5505	5-11	79
10N1274	19-7	113	25L5505	5-5	79
10N1326	5-9	79	25L5519	5-7	79
10N1327	5-7	79	25L5520	5-9	79
10N1328	5-8	79	25L5521	5-8	79
10N1346	1-19	71	30L6188	4-9	77
13H4850	5-2	79	30L6189	4-4	77
13H8311	3-9	75	30L6190	4-3	77
13H8312	3-16	75	30L6191	4-5	77
13H8313	1-3	71	30L6193	4-2	77
13H8313	3-15	75	30L6194	4-8	77
13H9612	1-	71	30L6214	4-7	77
13H9612	3-	75	30L6216	19-5	113
14J0747	5-11	79	30L6217	19-6	113
14J0747	5-5	79	30L6218	19-4	113
14J0797	5-11	79	30L6223	1-17	71
14J0797	5-5	79	30L6224	1-18	71
14J0797	6-6	81	30L6228	19-2	113
14J0802	5-11	79	30L6230	19-7	113
14J0802	5-5	79	30L6240	1-19	71
14R0023	22-5	119	30L6257	4-6	77
14R0024	22-3	119	30L6304	4-	77
14R1998	20-4	115	30L6320	19-1	113
14R1998	21-4	117	30L6322	19-3	113
15K2010	3-9	75	30L6365	19-8	113
1621594	1-10	71	30R0037	7-	84
1621594	2-10	73	30R0037	8-	87

Part Number	Asm-Index	Page
34L4286	1-17	71
34L4289	19-1	113
34L4315	19-8	113
39M5377	23-	121
41D0161	5-1	79
41D0163	6-2	81
41D0207	20-3	115
41D0207	21-3	117
41D0208	22-2	119
41D0209	20-	115
41D0209	21-	117
41D0210	21-1	117
41D0211	20-2	115
41D0211	21-2	117
41D0212	20-	115
41D0212	21-	117
41D0213	20-1	115
41D0214	22-1	119
41D0215	22-4	119
41D0216	22-	119
41D0261	20-1	115
41D0301	23-	121
41D0301	23-	121
41D0303	23-	121
41D0305	23-	121
41D0307	23-	121
41D0312	23-	121
41D0313	23-	121
41D7531	23-	122
41J6648	5-1	79
41J6683	5-1	79
41J6831	23-	121
41J6833	23-	121
41J6835	6-	81
41J6856	23-	121
41J6860	7-	83
41J6860	8-	87
41J6862	7-	83
41J6864	8-	87
41J6865	5-1	79
41J6887	13-	99
41J6889	13-	99
41J6891	13-	99
41J6893	13-	99
41J6895	13-	99
41J6897	13-	99
41J6899	13-	99
41J6901	13-	99
41J6903	13-	99
41J6905	13-	99
41J6907	13-	99
41J6909	13-	99
41J6911	13-	99

Part Number	Asm-Index	Page
41J6913	13-	99
41J6915	14-	103
41J6945	13-	99
41J6947	13-	99
41J6949	13-	99
41J6951	13-	99
41J6953	13-	99
41J6955	13-	99
41J6957	14-	103
41J6959	13-	99
41J7207	5-1	79
41J7207	5-1	79
41J7232	1-13	71
41J7232	2-12	73
41J7232	3-5	75
41J7251	9-	91
41J7252	9-	91
41J7253	9-	91
41J7254	11-	95
41J7255	10-	93
41J7256	10-	93
41J7257	9-	91
41J7258	9-	91
41J7259	11-	95
41J7260	10-	93
41J7260	14-1	103
41J7261	9-1	91
41J7262	9-1	91
41J7263	9-1	91
41J7264	11-1	95
41J7265	10-1	93
41J7266	10-1	93
41J7267	9-1	91
41J7268	9-1	91
41J7269	11-1	95
41J7270	10-1	93
41J7271	1-13	71
41J7271	2-12	73
41J7271	3-5	75
41J7272	1-1	71
41J7306	5-6	79
41J7307	5-6	79
41J7308	5-6	79
41J7693	2-	73
41J7694	2-	73
41J8004	6-1	81
41J8005	6-1	81
41J8006	6-1	81
41J8007	6-1	81
41J8008	6-1	81
41J8009	5-1	79
41J8010	6-1	81
41J8020	12-	97

last update: March 22, 2007

Part Number	Asm- Index	Page	Part Number	Asm- Index	Page
41J8021	12-	97	41J8085	23-	122
41J8023	12-1	97	41J8086	23-	122
41J8024	12-1	97	41J8087	23-	122
41J8032	8-	87	41J8088	23-	122
41J8033	8-	87	41J8089	23-	122
41J8034	8-	87	41J8090	23-	122
41J8035	8-	87	41J8091	23-	122
41J8036	8-	87	41J8092	23-	122
41J8037	8-	87	41J8093	23-	122
41J8038	8-	87	41J8094	23-	122
41J8039	7-	83	41J8095	23-	122
41J8040	7-	83	41J8096	23-	122
41J8041	7-	83	41J8097	23-	122
41J8042	7-	83	41J9163	10-4	93
41J8043	7-	83	41J9163	10-8	93
41J8044	7-	83	41J9163	11-4	95
41J8045	7-	83	41J9163	12-4	97
41J8046	7-	83	41J9163	12-7	97
41J8047	7-	83	41J9163	13-4	99
41J8048	7-	83	41J9163	14-4	103
41J8049	7-	83	41J9163	7-2	83
41J8050	7-	83	41J9163	8-	87
41J8051	7-	83	41J9163	9-4	91
41J8052	7-	83	41J9164	8-2	87
41J8053	13-1	99	41J9165	10-2	93
41J8055	13-1	99	41J9165	12-2	97
41J8056	13-1	99	41J9165	13-2	99
41J8057	13-1	99	41J9165	7-	83
41J8058	13-1	99	41J9166	10-3	93
41J8059	13-1	99	41J9166	12-3	97
41J8060	13-1	99	41J9166	13-3	99
41J8061	13-1	99	41J9166	9-3	91
41J8062	13-1	99	41J9167	10-6	93
41J8063	13-1	99	41J9167	12-5	97
41J8064	13-1	99	41J9167	13-5	99
41J8065	13-1	99	41J9167	14-5	103
41J8066	13-1	99	41J9168	13-1	99
41J8067	14-1	103	41J9168	7-3	83
41J8068	13-1	99	41J9169	8-	87
41J8069	13-1	99	41J9170	10-7	93
41J8070	13-1	99	41J9170	12-6	97
41J8071	13-1	99	41J9170	13-6	100
41J8072	13-1	99	41J9170	7-	83
41J8073	13-1	99	41J9170	9-6	91
41J8075	13-1	99	41J9171	13-7	100
41J8077	23-	122	41J9171	14-7	103
41J8078	23-	122	41J9171	7-	83
41J8079	23-	122	41J9173	11-3	95
41J8080	23-	122	41J9173	14-3	103
41J8081	23-	122	41J9174	11-2	95
41J8082	23-	122	41J9174	14-2	103
41J8083	23-	122	41J9175	10-6	93
41J8084	23-	122	41J9175	12-5	97

Part Number	Asm-Index	Page	Part Number	Asm-Index	Page
41J9175	13-5	100	41K6965	7-1	83
41J9176	10-3	93	41K6967	7-1	83
41J9176	12-3	97	41K6969	7-1	83
41J9176	13-3	99	42H3791	1-	71
41J9176	9-3	91	42K0131	8-1	87
41J9177	11-5	95	42K0172	8-1	87
41J9177	9-5	91	42K0175	8-1	87
41J9178	10-5	93	42K0178	8-1	87
41J9179	10-5	93	42K0181	8-1	87
41J9180	11-5	95	42K0184	8-1	87
41J9180	9-5	91	42K0187	8-1	87
41J9195	9-2	91	42K0197	8-1	87
41J9217	14-6	103	42K0241	8-1	87
41J9250	23-	121	42K0261	8-1	87
41J9251	1-1	71	42K0264	8-1	87
41J9251	2-1	73	42K0267	8-1	87
41J9271	1-1	71	42K0270	8-1	87
41J9272	23-	121	42K0273	8-1	87
41J9274	1-15	71	42M5591	23-	121
41J9274	2-14	73	42M5593	23-	121
41J9274	3-8	75	42M5594	23-	121
41J9275	1-8	71	42M5596	23-	121
41J9275	2-8	73	42M5597	7-	83
41J9276	1-9	71	42M5597	8-	87
41J9276	2-9	73	42M5599	7-	83
41J9282	1-7	71	42M5599	8-	87
41J9282	3-10	75	42M5600	8-	87
41J9292	3-1	75	42M5602	8-	87
41J9293	3-1	75	42M5603	23-	121
41J9294	3-1	75	42M5605	23-	121
41J9299	3-13	75	42M5606	23-	121
41J9307	1-11	71	42M5608	23-	121
41J9307	3-3	75	42M5610	23-	121
41J9487	1-6	71	42M5612	23-	121
41J9487	2-6	73	42M5615	23-	121
41J9487	3-12	75	42M5616	23-	121
41J9488	2-17	73	42M5622	23-	121
41J9489	2-17	73	42M5625	23-	121
41J9490	23-	121	42M5626	23-	121
41J9672	3-18	75	42M5628	23-	121
41K6848	5-1	79	42M5630	23-	121
41K6876	5-1	79	42M5632	23-	121
41K6943	7-1	83	42M5634	6-	81
41K6945	7-1	83	42M5637	23-	121
41K6947	7-1	83	42M5639	23-	121
41K6949	7-1	83	42M5641	6-	81
41K6951	7-1	83	42M5643	6-	81
41K6953	7-1	83	42M5646	6-	81
41K6955	7-1	83	42M5647	6-	81
41K6957	7-1	83	42M5649	6-	81
41K6959	7-1	83	42M5653	23-	121
41K6961	7-1	83	42M5653	23-	121
41K6963	7-1	83	42M5657	23-	121

last update: March 22, 2007

Part Number	Asm-Index	Page	Part Number	Asm-Index	Page
42M5659	23-	121	6316718	2-	73
42M5662	23-	121	72H3118	23-	121
42M5663	23-	121	74F6307	2-	73
42M5667	23-	121	76X0200	2-	73
42M5668	23-	121	90X9640	10-	93
42M5937	6-1	81	90X9640	12-	97
42M5938	6-1	81	90X9640	13-	100
42M5939	6-1	81	90X9640	7-	83
42P8025	1-	71	90X9640	8-	87
44D0271	6-1	81	90X9640	9-	91
4783875	1-	71	92F6315	13-	99
4783875	2-	73	92F6316	13-	99
4783876	1-	71	92F6317	13-	99
4783876	2-	73	93F0663	20-5	115
4783877	1-	71	93F1779	2-1C	73
4783877	2-	73	93F1780	2-1A	73
4783878	1-	71	93F1795	2-1B	73
4783878	2-	73	93F1897	1-5	71
4783879	1-	71	93F1897	2-5	73
4783879	2-	73	93F1901	1-2	71
4783880	1-	71	93F1901	2-2	73
4783880	2-	73	93F1902	1-3	71
47F8031	16-3	107	93F1902	2-3	73
47L7994	18-2	111	93F1902	3-15	75
47L7995	18-1	111	93F1903	3-3	75
47L8032	16-4	107	93F1904	1-16	71
47L8033	17-1	109	93F1904	2-15	73
47L8035	15-5	105	93F1908	1-4	71
47L8040	16-4	107	93F1908	2-4	73
47L8064	23-	121	93F1910	2-7	73
47L8067	23-	121	93F1912	1-	71
47P9273	22-6	119	93F1913	1-14	71
48G9012	15-	105	93F1913	2-13	73
48G9012	16-	107	93F1913	3-6	75
48G9013	15-	105	93F1915	1-12	71
48G9013	16-	107	93F1915	2-11	73
48G9014	15-	105	93F1915	3-4	75
48G9014	16-	107	93F1937	13-1	99
48G9015	15-	105	93F1950	7-	84
48G9015	16-	107	93F1951	7-	84
48G9027	16-5	107	93F1952	7-	84
48G9028	15-	105	93F1953	7-	84
48G9028	16-	107	94G3245	16-2	107
48G9029	15-	105	95F3180	15-4	105
48G9029	16-	107	95F3181	15-2	105
48G9045	11-	95	95F3182	15-3	105
48G9045	14-	103	95F3184	15-1	105
54P8829	8-	87	95F3195	16-1	107
54P8830	8-	87	95F3196	16-1	107
55H6864	1-2	71	95F3229	15-	105
55H6865	1-4	71	95F3278	16-5	107
6316718	1-	71			

Readers' Comments — We'd Like to Hear from You

**Point of Sale
Options and I/O Devices Service Guide**

Publication No. GC30-9737-00

We appreciate your comments about this publication. Please comment on specific errors or omissions, accuracy, organization, subject matter, or completeness of this book. The comments you send should pertain to only the information in this manual or product and the way in which the information is presented.

For technical questions and information about products and prices, please contact your IBM branch office, your IBM business partner, or your authorized remarketer.

When you send comments to IBM, you grant IBM a nonexclusive right to use or distribute your comments in any way it believes appropriate without incurring any obligation to you. IBM or any other organizations will only use the personal information that you supply to contact you about the issues that you state on this form.

Comments:

Thank you for your support.

Submit your comments using one of these channels:

- Send your comments to the address on the reverse side of this form.

If you would like a response from IBM, please fill in the following information:

Name

Address

Company or Organization

Phone No.

E-mail address



Fold and Tape

Please do not staple

Fold and Tape



NO POSTAGE
NECESSARY
IF MAILED IN THE
UNITED STATES

BUSINESS REPLY MAIL

FIRST-CLASS MAIL PERMIT NO. 40 ARMONK, NEW YORK

POSTAGE WILL BE PAID BY ADDRESSEE

IBM Corporation
Retail Store Solutions Information Development
Dept ZBDA
P. O. Box 12195
RESEARCH TRIANGLE PARK NC 27709-9990

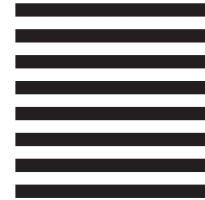

Fold and Tape

Please do not staple

Fold and Tape



last update: March 22, 2007

GC30-9737-00

