

TeamPoS 2000

FUJITSU

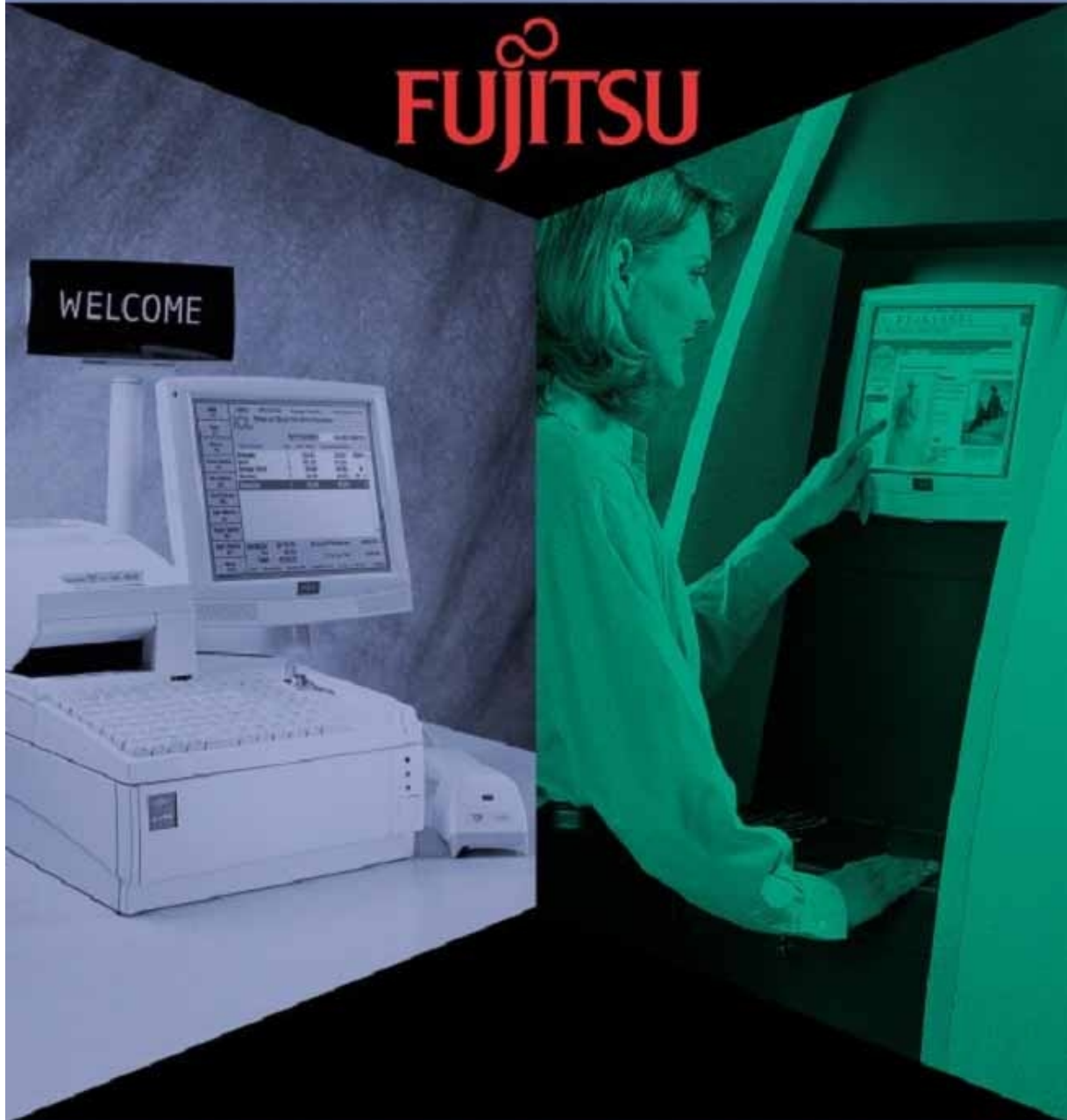

Installation and Maintenance Manual

*Team***PoS** 2000®

Installation and Maintenance
Manual

This page intentionally left blank

Fujitsu Transaction Solutions Inc. endeavors to ensure that the information in this document is correct and fairly stated but does not accept liability for any error or omission.

The development of Fujitsu products and services is continuous and published information may not be up to date. It is important to check the current position with Fujitsu Transaction Solutions Inc. This document is not part of a contract or license save insofar as may be expressly agreed.

This document was originally issued September 2000 with revisions as follows:

| Issue Date | Revision |
|---------------------------|----------|
| September 2000 (original) | 1.0 |
| November 2000 | 1.1 |
| October 2001 | 2.0 |
| March 2002 | 2.2 |
| October 2002 | 2.3 |
| September 2003 | 2.4 |
| July 2004 | 3.0 |

Regulatory Information

Emissions

Radio Frequency Interference Requirements – U.S.A.

This equipment has been tested and found to comply with the limits for a Class A digital device pursuant to Part 15 of the FCC Rules. These limits are designed to provide reasonable protection against harmful interference when the equipment is operated in a commercial environment. This equipment generates, uses, and can radiate radio frequency energy and, if not installed and used in accordance with the instruction manual, may cause harmful interference to radio communications. Operation of this equipment in a residential area is likely to cause harmful interference in which case the user will be required to correct the interference at his own expense.

Radio Frequency Interference Requirements – Canada

This Class A digital apparatus meets all the requirements of the Canadian Interference-Causing Equipment Regulations.

Cet appareil numérique de la classe A respecte toutes les exigences du Règlement sur le matériel brouilleur du Canada.

Radio Frequency Interference Requirements – Europe

This apparatus has been tested and found to comply with the limits for a Class A digital device, per EN55022, for use in Information Technology equipment. In a domestic environment this product may cause radio interference in which case the user may be required to take adequate measures. This apparatus also meets the susceptibility requirements per EN55024. Overall the product qualifies for and bears the CE mark.

Safety

Lithium & Lead Acid Battery



Caution: There is a danger of explosion if the lead acid battery is incorrectly replaced. Replace only with the battery listed in Chapter 10. Dispose of the used battery according to manufacturer's instruction.



Warning: Handling cords included with this product will expose you to lead, a chemical known to the State of California to cause birth defects or other reproductive harm. *Wash hands after handling.*

Warning: The LCD's used with this product may contain a backlight that contains mercury. Please dispose of according to local, state, or federal laws.

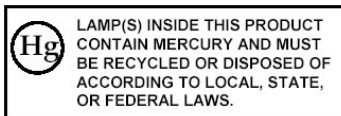

Table of Contents

Chapter 1 Overview **1-1**

 1.1 TeamPoS 2000 Control Unit Flow Diagram 1-2

 1.2 Front Panel LEDs and Switches 1-3

 1.2.1 TeamPoS 2000 Front Panel Switch and LCD Matrix 1-4

 1.3 Intelligent PINs (Product Identification Numbers) 1-5

Chapter 2 - EXTERNAL VIEW AND ENVIRONMENTAL SPECIFICATIONS **2-1**

 2.1 Environmental Specifications 2-2

Chapter 3 DIMENSIONS **3-1**

 3.1 Standard TeamPoS 2000 15" LCD Stacked Configuration 3-1

 3.2 Compact TeamPoS 2000 12.1" LCD Stacked Configuration Dimensions 3-2

 3.3 Standard TeamPoS 2000 12.1" LCD Stacked Configuration Dimensions 3-2

 3.4 Control Units 3-3

 3.5 Keyboards 3-4

 3.5.1 Model 133UQ Keyboard Dimensions 3-4

 3.5.2 Model 104P Keyboard Dimensions 3-4

 3.5.3 Model 133PQ Keyboard Dimensions 3-5

 3.5.4 Basic Model 92M and 92U Keyboard Dimensions 3-5

 3.5.5 Model 92M & 92U Keyboard with MSR and Display Dimensions 3-6

 3.5.6 Model 92M Keyboard with Vertical Key-Lock Dimensions 3-6

 3.6 Cash Drawers 3-7

 3.6.1 Model TP10 Cash Drawer 3-7

 3.6.2 MP5 Cash Drawer, Compact 3-7

 3.6.3 NF5 Cash Drawer 3-8

 3.6.4 Model NAF Cash Drawer 3-8

 3.7 Displays 3-9

| | | |
|--------|--|------|
| 3.7.1 | Model D15 LCD Displays (<i>New Release</i>) | 3-9 |
| 3.7.2 | LCD Bracket Mounting | 3-10 |
| 3.7.3 | Single Stacked D15 LCD | 3-10 |
| 3.7.4 | Single Stacked D15 LCD w/customer display | 3-11 |
| 3.7.5 | Single Dispersed D15 LCD | 3-11 |
| 3.7.6 | Single Dispersed LCD with MSR | 3-12 |
| 3.7.7 | Single Dispersed D15 with Keypad and MSR | 3-12 |
| 3.8 | Models D12 and A12 LCD Displays | 3-13 |
| 3.8.1 | LCD Bracket Mounting | 3-14 |
| 3.8.2 | Single Stacked LCD | 3-15 |
| 3.8.3 | Single Dispersed LCD with dispersed stand | 3-15 |
| 3.8.4 | Single Dispersed LCD – Alternate Mount | 3-16 |
| 3.8.5 | TeamKey | 3-16 |
| 3.8.6 | LCD with MSR (dispersed) | 3-17 |
| 3.8.7 | Dual Stacked LCD | 3-17 |
| 3.8.8 | Other Options | 3-18 |
| 3.8.9 | CRTs, 9" | 3-18 |
| 3.8.10 | CRT, 14" | 3-19 |
| 3.8.11 | VF50 & VF50U Customer Displays (dispersed configuration) | 3-20 |
| 3.9 | Printers | 3-21 |
| 3.9.1 | Model DT50/DT50II Printer | 3-21 |
| 3.9.2 | Model DT50II TranScan Printer | 3-21 |
| 3.9.3 | Model TM-T88III Printer | 3-22 |
| 3.9.4 | Model TM-T90 Printer | 3-22 |
| 3.9.5 | Model A758 & A760 Printers | 3-23 |
| 3.9.6 | Model A794 Printer | 3-23 |

Chapter 4 SITE PREPARATION 4-1

 4.1 Unpacking 4-1

 4.2 Inspecting the Shipment 4-1

 4.3 Reporting Shipment Damage 4-2

 4.4 Returning Equipment 4-2

 4.5 Using Anti-static Protection 4-2

 4.6 Preparing for Installation: 4-2

 4.7 Determining Power Requirements 4-3

 4.8 General Requirements 4-3

 4.9 Installation with Other Equipment 4-4

 4.10 Mains Power Cable 4-5

Chapter 5 INSTALLATION 5-1

 5.1 Cover Removal/Installation Process 5-1

 5.1.1 Front Cover 5-1

 5.1.2 Side Cover (Left) 5-2

 5.1.3 Rear Cover 5-3

 5.1.4 Top Cover 5-4

 5.1.5 Installing D12 and A12 LCD Brackets 5-7

 5.1.6 PCI Add-In Card(s) 5-10

 5.2 Adding Main Memory 5-11

 5.2.1 Memory Configuration 5-11

 5.3 Accessing and Configuring 5-12

 5.3.1 Retail I/O Board Pin layout 5-12

 5.3.2 Retail I/O Board Settings 5-13

 5.3.3 Printer Jumpers 5-14

 5.3.4 PTR (Printer) Connector Signals 5-15

 5.3.5 Retail I/O Board. Ports 1 and 2 Connector Signals 5-16

 5.3.6 Retail I/O Board.Port 5 Connector Signals 5-16

| | | |
|-------|--|------|
| 5.3.7 | Retail I/O BoardPorts 3, 4 & 6 Connector Signals | 5-17 |
| 5.3.8 | DRW Connector Signals | 5-17 |
| 5.4 | Installing the TeamCOMBO Board | 5-18 |
| 5.4.1 | TeamCOMBO Board Pin Layout | 5-18 |
| 5.4.2 | TeamCOMBO Board Settings | 5-19 |
| 5.4.3 | TeamCOMBO Board. Ports 1 and 2 Connector Signals | 5-20 |
| 5.4.4 | TeamCOMBO Board. Ports 3 and 4 Connector Signals | 5-21 |
| 5.4.5 | DRW Connector Signals | 5-21 |
| 5.4.6 | TeamCOMBO Board. USB Connectors – 4 Ports | 5-22 |
| 5.5 | TeamUSB Settings | 5-23 |
| 5.5.1 | TeamUSB Board. USB Connectors - 7 Ports | 5-24 |
| 5.5.2 | TeamUSB Board DRW Connector Signals | 5-25 |
| 5.5.3 | TeamUSB Board, Powered USB Connectors - 7 ports | 5-25 |
| 5.6 | Riser Card Connectors | 5-26 |
| 5.7 | CD-ROM/CD-RW/DVD (Media Player) Installation | 5-27 |
| 5.8 | PoS Peripheral Installation | 5-29 |
| 5.8.1 | Model 133UQ Keyboard Unit (programmable) | 5-29 |
| 5.8.2 | Model 92U Keyboard Unit (programmable) | 5-30 |
| 5.8.3 | Model 133PQ Keyboard Unit (not programmable) | 5-31 |
| 5.8.4 | Model 104P Keyboard Unit (Compact Keyboard) | 5-33 |
| 5.9 | Model D15 LCD Stands | 5-37 |
| 5.9.1 | D15 LCD Cable Requirements | 5-37 |
| 5.9.2 | D15 LCD Audio Cable Connections | 5-37 |
| 5.9.3 | D15 LCD Video Data Cable Connections | 5-39 |
| 5.9.4 | D15 LCD Dual Monitor Video Cable Connections | 5-40 |
| 5.9.5 | D15 LCD Power and Data (Touch, MSR and Keypad) Cable Connections | 5-41 |
| 5.9.6 | D15 Cable Summary | 5-45 |

5.9.7 Model D15 LCD Installation 5-46

5.10 Models D12 and A12 LCD Installation 5-54

5.10.1 Model D12 and A12 LCD Stand Option Summary 5-54

5.10.2 12.1" LCD Cable Requirements 5-55

5.10.3 A12/D12 Cable Summary 5-60

5.10.4. D12/A12 LCD Stand and Rotating Arm Assembly 5-61

5.10.5 Model VF50 & VF50U Integrated Customer Display with D12/A12 LCD 5-63

5.10.6 D12/A12 LCD with TeamKey Assembly 5-66

5.10.7 Models D12 and A12 LCD, 12.1” Adjustments 5-70

5.10.8 Model VF50 and VF50U Customer Display Settings 5-71

5.11 Cash Drawers 5-74

5.12 Connecting Retail I/O, TeamCOMBO & TeamUSB Board Cables 5-75

5.12.1 TeamPoS 2000 with Retail I/O Board Connector Layout-A Motherboard 5-76

5.12.2 TeamPoS 2000 with TeamCOMBO Board Connector Layout-A Motherboard 5-78

5.12.3 TeamPoS 2000 with TeamUSB Board Connector Layout
with A Motherboard 5-79

5.12.4 TeamPoS 2000 M with TeamUSB Board Connector Layout
with M Motherboard 5-80

Chapter 6 GENERAL OPERATIONS 6-1

6.1 System Operations 6-1

6.1.1 General Care and Maintenance 6-1

6.1.2 Power ON and OFF Sequence 6-2

6.1.3 Powering ON 6-2

6.1.4 Powering OFF 6-3

Chapter 7 MAINTENANCE 7-1

7.1. Power ON and OFF Sequence 7-1

7.1.1 Powering ON 7-2

7.1.2 Powering OFF 7-3

| | | |
|--|---|------------|
| 7.2 | PC Board Replacement | 7-3 |
| 7.3 | M Motherboard Layout | 7-5 |
| 7.3.1 | M Motherboard Settings | 7-6 |
| 7.3.2 | Picture of M Motherboard | 7-8 |
| 7.3.3 | A Motherboard Layout | 7-9 |
| 7.4 | A Motherboard Settings | 7-10 |
| 7.5 | Lead Acid Battery Replacement | 7-11 |
| 7.6 | Power Supply Unit Replacement | 7-12 |
| 7.7 | HDD Kit Replacement | 7-14 |
| 7.8 | FDD Unit Replacement | 7-16 |
| 7.9 | CD-ROM/CD-Read/Write/DVD (Media Player) Kit Replacement | 7-17 |
| 7.10 | Operator Panel | 7-18 |
| 7.10.1 | Operator Panel Layout | 7-19 |
| 7.10.2 | Operator Panel Settings | 7-19 |
| 7.11 | Memory (DIMM or SDRAM) | 7-20 |
| 7.12 | Chassis Fan | 7-22 |
| 7.13 | Retail I/O, TeamCOMBO and TeamUSB Board Replacement | 7-23 |
| 7.14 | Riser Card | 7-25 |
| Chapter 8 BIOS Setup Procedures - M Motherboard | | 8-1 |
| 8.1 | Opening CMOS Setup Screen | 8-1 |
| 8.1.1 | CMOS Settings | 8-1 |
| 8.1.2 | Main Menu - M Motherboard | 8-2 |
| 8.1.3 | Advanced Settings - M Motherboard | 8-3 |
| 8.1.4 | Configure Advanced CPU Settings - M Motherboard | 8-4 |
| 8.1.5 | IDE Configuration - M Motherboard | 8-5 |
| 8.1.6 | Primary IDE Master - M Motherboard | 8-6 |
| 8.1.7 | Primary IDE Slave - M Motherboard | 8-7 |

8.1.8 Secondary IDE Master - M Motherboard 8-8

8.1.9 Floppy configuration - M Motherboard 8-9

8.1.10 Configure Win627 Super IO Chipset - M Motherboard 8-10

8.1.11 Hardware Health Configuration - M Motherboard 8-11

8.1.12 ACPI Settings - M Motherboard 8-12

8.1.13 General ACPI Configuration - M Motherboard 8-13

8.1.14 Advanced ACPI Configuration - M Motherboard 8-14

8.1.15 Event Logging Details - M Motherboard 8-15

8.1.16 Configure Remote Access Type and Parameters - M Motherboard 8-16

8.1.17 USB Configuration - M Motherboard 8-17

8.1.18 Advanced PCI/PnP Settings - M Motherboard 8-18

8.1.19 Boot Settings - M Motherboard 8-19

8.1.20 Boot Settings Configuration - M Motherboard 8-20

8.1.21 Boot Group Priority - M Motherboard 8-21

8.1.22 Boot Device Priority - M Motherboard 8-22

8.1.23 Hard Disk Drives - M Motherboard 8-23

8.1.24 Removable Drive - M Motherboard 8-24

8.1.25 CD ROM Drives - M Motherboard 8-25

8.1.26 Security Settings - M Motherboard 8-26

8.1.27 Advanced Chipset Settings - M Motherboard 8-27

8.1.28 Configure Advanced Settings for NorthBridge - M Motherboard 8-28

8.1.29 Configure Advanced Settings for SouthBridge - M Motherboard 8-29

8.1.30 Advanced SMI Enable/Resume Event controls - M Motherboard 8-31

8.1.31 Clock Margin - M Motherboard 8-32

8.1.32 Exit Options - M Motherboard 8-33

8.2 BIOS Error Messages - M Motherboard 8-34

8.3 BIOS Reflash Instructions - M Motherboard 8-35

| | |
|--|-------------|
| Chapter 9 BIOS SETUP PROCEDURES - A Motherboard | 9-1 |
| 9.1 Opening CMOS Setup Screen - A Motherboard | 9-1 |
| 9.1.1 CMOS Settings - A Motherboard | 9-1 |
| 9.1.2 Main Menu - A Motherboard | 9-1 |
| 9.1.3 Standard CMOS Setup - A Motherboard | 9-2 |
| 9.1.4 BIOS Features Setup - A Motherboard | 9-3 |
| 9.1.5 Chipset Features Setup- A Motherboard | 9-4 |
| 9.1.6 Power Management Setup - A Motherboard | 9-5 |
| 9.1.7 PNP/PCI Configuration | 9-6 |
| 9.1.8 Load BIOS Defaults | 9-7 |
| 9.1.9 Load SETUP Defaults | 9-7 |
| 9.1.10 Clock and Sensor | 9-7 |
| 9.1.11 Integrated Peripherals | 9-9 |
| 9.1.12 Supervisor Password | 9-10 |
| 9.1.13 User Password | 9-10 |
| 9.1.14 IDE HDD Auto Detection | 9-10 |
| 9.1.15 Save & Exit SETUP | 9-10 |
| 9.1.16 Exit Without Saving | 9-10 |
| 9.1.17 BIOS Error Messages | 9-10 |
| 9.1.18 BIOS Beep Code | 9-13 |
| Chapter 10 SPARE AND UPGRADE PARTS LIST | 10-1 |

This page intentionally left blank.

Chapter 1 Overview

The following sections provide a brief overview of the TeamPoS 2000 control units and peripherals:



The TeamPoS 2000 is a state-of-the-art Point-of-Sale (PoS) terminal. It contains standard PC components such as CPU, memory, hard disk, video and audio and can be used as a PC, subject to operating system and licensing restrictions, to run standard PC applications, such as word processing, spreadsheets, etc. The TeamPoS 2000 also contains functionality required by retail application software and is "retail hardened" to support the harsh environments found in most retail stores. Depending on the application requirements, there are a very large number of possible configurations. Memory capacity, hard disk number, CPU speed and the numbers of powered RS232 and USB ports are selectable by the customer. Chassis configurations, memory, memory storage devices, and operating systems are also selectable.

1.1 TeamPoS 2000 Control Unit Flow Diagram

The following graphic shows a high level overview of the TeamPoS 2000 Control Unit.

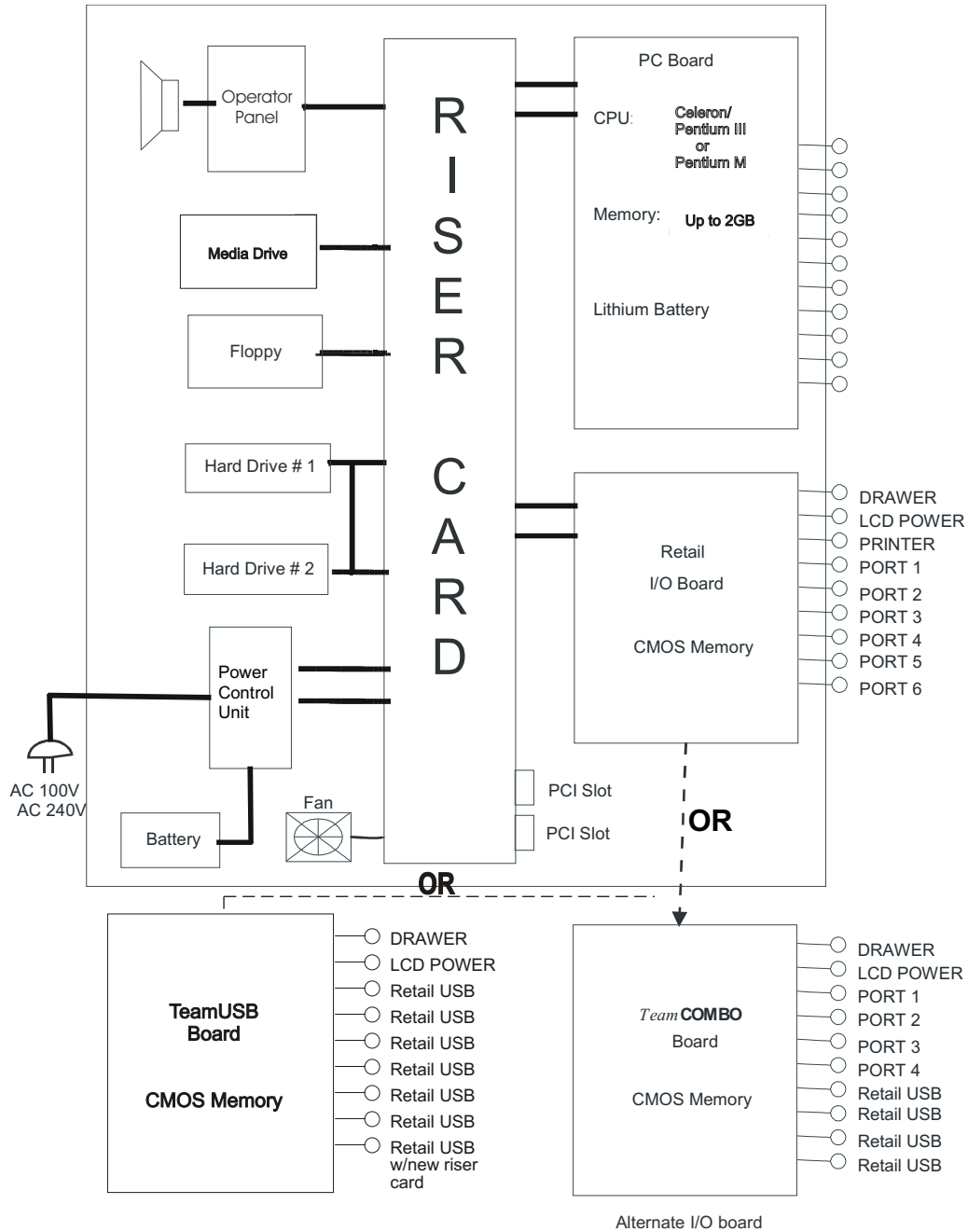

1.2 Front Panel LEDs and Switches

The following graphic and table show the TeamPoS 2000 unit LEDs and switches.

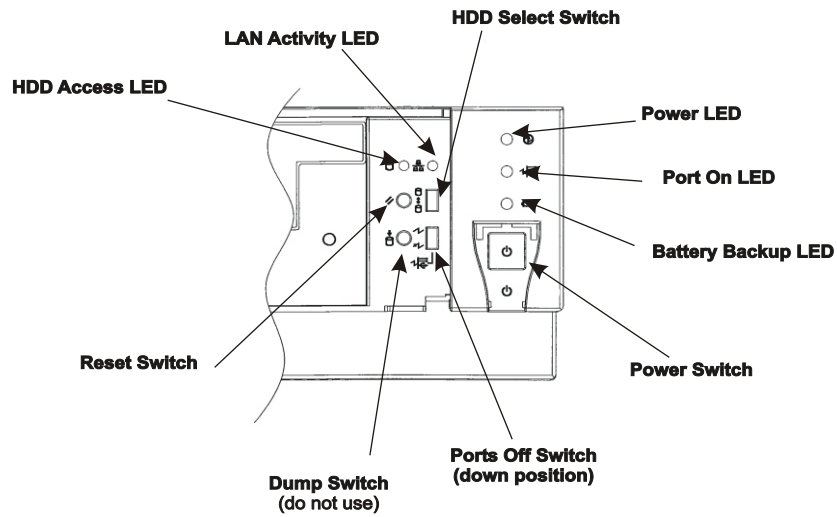

1.2.1 TeamPoS 2000 Front Panel Switch and LCD Matrix

| Name Switch/LED | Mounting Position | LED Color | Remark |
|-------------------------|-----------------------|-----------------|--|
| Power SW | Outside of Front Door | — | Depending on BIOS setup, the power switch can be instant off or delayed off. |
| Reset SW | Inside of Front Door | — | PC board resets. |
| Dump SW (DO NOT USE) | Inside of Front Door | — | Resets CMOS memory on Retail I/O, TeamCOMBO® or TeamUSB® Board. |
| Port On/Off SW | Inside of Front Door | — | Interrupts power to the I/O board's RS232 ports and the LCD power port. (For the original TeamCOMBO board, the switch also interrupts power to USB ports on the TeamCOMBO board. For the revised TeamCOMBO board, the switch interrupts power only for the RS232 and LCD power ports.) |
| HDD Select SW | Inside of Front Door | — | Selects master HDD between primary and secondary HDD. The hard drives must be jumpered to Cable Select (CS) in order to allow switching of disks. |
| Power LED | Outside of Front Door | Green | This LED is illuminated when power is supplied including during battery backup mode. It blinks when power switch is pressed in delayed off mode. |
| Port On LED | Outside of Front Door | Green | This LED is illuminated when the port on/off switch is set to on. |
| Battery Backup LED | Outside of Front Door | Blinking Yellow | This LED is turned on and blinking when the power is supplied from lead-battery (i.e., when battery backup is enabled due to AC power loss.). |
| HDD Access LED | Inside of Front Door | Green | Indicates hard disk access activity. |
| LAN Activity LED | Inside of Front Door | Green | Illuminates with LAN activity. |



Caution: It is assumed that the user of this manual fully understands and strictly adheres to proper Electrostatic Discharge (ESD) precautions. Failure to adhere to precautions can cause damage to this equipment.

Always remove the power cord from the unit prior to performing any controller maintenance.

1.3 Intelligent PINs (Product Identification Numbers)

All control units have a number called an Intelligent PIN. This number specifies the configuration as manufactured. The following lists the options. If the actual configuration of the control unit is different than the Intelligent PIN, it was upgraded/changed after being manufactured. An upgrade label will be added whenever an upgrade (memory, CPU, disk drive, etc.) is installed.

Intelligent PIN Digits Rev 22.0 (Pentium M version)

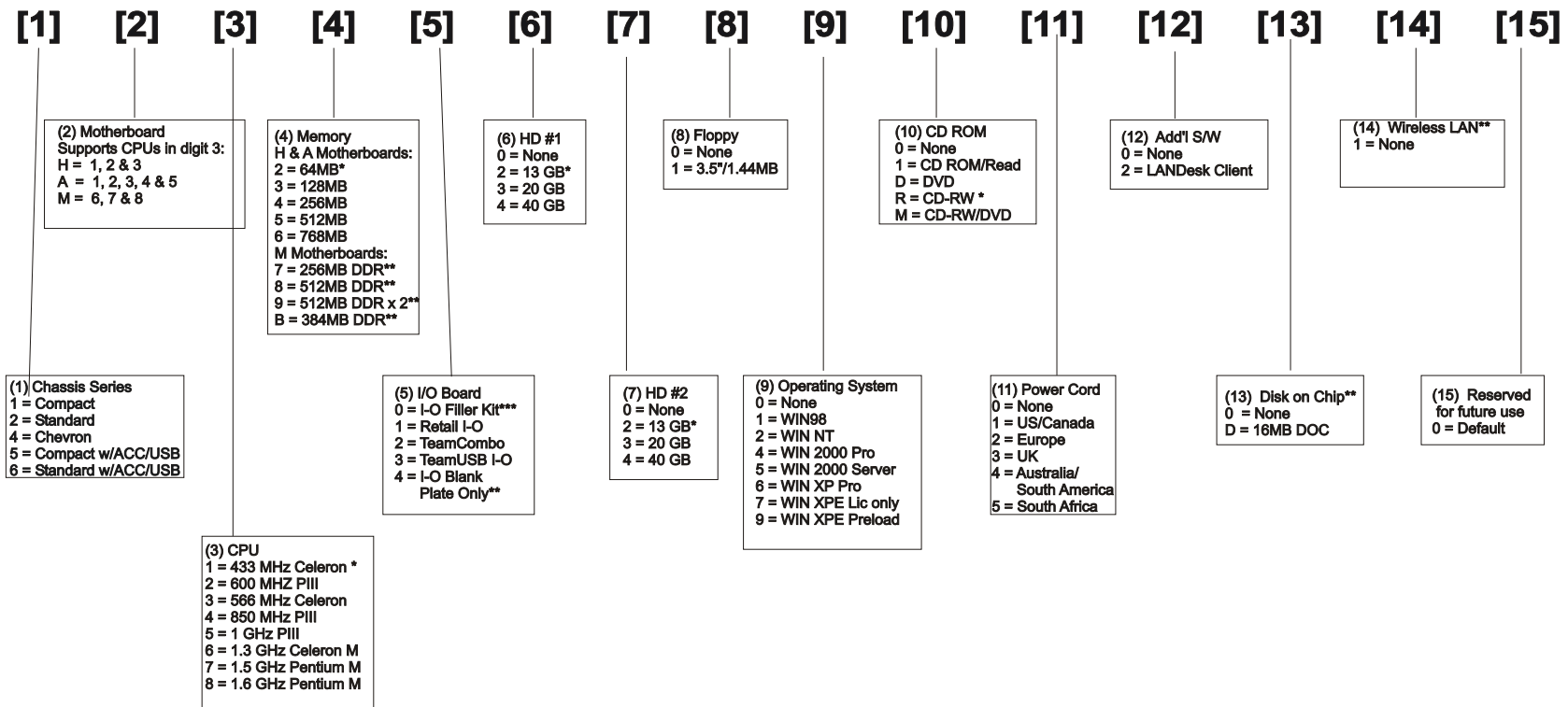

* = Withdrawn
 ** = M motherboard only
 *** = Non Pentium M motherboard only

This page intentionally left blank.

Chapter 2 - EXTERNAL VIEW AND ENVIRONMENTAL SPECIFICATIONS

EXTERNAL VIEW (Standard Series without cash drawer)



Note: This is a typical integrated configuration. Depending on the store environment, the configuration and components may differ.

2.1 Environmental Specifications

| Specifications | | Unit | | | | |
|--------------------------------|--------------------------------|-----------------------------|----------|--------------------------------|--------------------------------|---------------------------------|
| | | TP2000 Main Unit | | 133PQ/UQ Keyboards | 92M/U Keyboards | 104P Key Compact Keyboard |
| | | Compact | Standard | | | |
| Clearance Space | Front | 75mm 3" | | N/A | N/A | N/A |
| | Rear | 50mm 2" | | N/A | N/A | N/A |
| | Right | 0 | | N/A | N/A | N/A |
| | Left | 0 | | N/A | N/A | N/A |
| Weight (component only) | | 12kg. 26.5 lb. | | 1.1kg. 2.5 lb. | 1.2 kg. 2.5 lb. | 1.1 kg. 2.5 lb. |
| Power source condition | Voltage | 100 to 240 VAC ±10% | | Supplied from the main unit | Supplied from the main unit | Supplied from the main unit |
| | Amps | Max 15 Amp | | | | |
| | Grounding | Class 3 grounding | | | | |
| Temperature °C (°F) | Operating | 0 to 40 (32 to 104) | | 0 to 40 (32 to 104) | 0 to 40 (32 to 104) | 0 to 40 (32 to 104) |
| | Non- operating ¹ | -5 to 40 (+23 to +104) | | -30 to 60 (-22 to +140) | -30 to 60 (-22 to +140) | -5 to 50 (+23 to +122) |
| | Storage & shipping | -30 to +60 (-22 to +140) | | -30 to +60 (-22 to +140) | -30 to +60 (-22 to +140) | -30 to +60 (-22 to +140) |
| Humidity % (Non-condensing) | Operating | 20 to 80 | | 20 to 80 | 20 to 80 | 20 to 80 |
| | Non- operating | 10 to 95 | | 10 to 95 | 10 to 95 | 10 to 95 |
| | Storage & shipping | 10 to 95 | | 10 to 95 | 10 to 95 | 10 to 95 |
| Power Outlet | | CRT: 1.8 Amps (Max) | | N/A | N/A | N/A |

- ¹ Non-operating means that equipment can be powered on with no damage. Performance is not guaranteed until returned to normal temperature.

| Specifications | | Unit | | | | |
|--------------------------------|--------------------|--|-----------------------------|--|-----------------------------|-----------------------------|
| | | D15 LCD Display | A12/D12 LCD Display | Integrated Customer Display (low-pole) | DT50II Printer | Compact Cash Drawer |
| Weight (component only) | | 4.1 kg, 9.0 lb. | 3.3 kg. 7.3 lb. | 1.1 kg. 2.5 lb. | 5.8 kg. 12.8 lb. | 6.4kg. 14.1 lb. |
| Power source condition | Voltage | Supplied from the main unit or power brick | Supplied from the main unit | Supplied from the main unit | Supplied from the main unit | Supplied from the main unit |
| | Amps | | | | | |
| | Grounding | | | | | |
| Temperature °C (°F) | Operating | 0 to 40 (32 to 104) | 0 to 40 (32 to 104) | 5 to 40 (41 to 104) | 0 to 40 (32 to 104) | 5 to 40 (41 to 104) |
| | Non-Operating | -5 to +50 (+23 to 104) | -5 to +50 (+23 to 104) | -5 to +50 (+23 to 122) | -5 to +50 (+23 to 122) | -5 to +50 (+23 to 122) |
| | Storage & shipping | -40 to +70 (-40 to 158) | -5 to +40 (+23 to 104) | -5 to +50 (+23 to 122) | -5 to +50 (+23 to +122) | -5 to +50 (+23 to +122) |
| Humidity % (Non-condensing) | Operating | 10 to 85 | 10 to 95 | 10 to 95 | 10 to 95 | 10 to 95 |
| | Non-Operating | 10 to 90 | 8 to 95 | 8 to 95 | 10 to 95 | 8 to 95 |
| | Storage & shipping | 10 to 90 | 8 to 95 | 8 to 95 | 10 to 95 | 8 to 95 |

This page intentionally left blank.

Chapter 3 DIMENSIONS

This section shows the dimensions of the TeamPoS 2000 control unit and peripherals. Other peripherals may be included in the configurations. For peripherals not shown, refer to the appropriate documentation. Dimensions are approximate external and in millimeters (inches).

The TeamPoS 2000 control unit is available in two sizes, compact and standard. Both units can be stacked, where peripherals (printer, keyboard, operator display and customer display) are stacked on top of the control unit. This requires brackets to be installed on the control unit that restrain movement of the peripherals. The new D15 LCD display can only be stacked on the standard control unit. The 12.1" LCD can be stacked on either the standard or compact control unit. The cash drawer, if stacked, is located under the control unit. Only the model MP5 cash drawer can be stacked with the compact control unit and only the model TP10 with the standard unit

Dispersed configurations do not stack the peripherals. Instead the control unit and/or cash drawer is located under the checkstand or counter and peripherals are installed on the checkstand or counter. Dispersed configurations require longer cables. Partially dispersed configurations stack some peripherals and disperse others.

3.1 Standard TeamPoS 2000 15" LCD Stacked Configuration

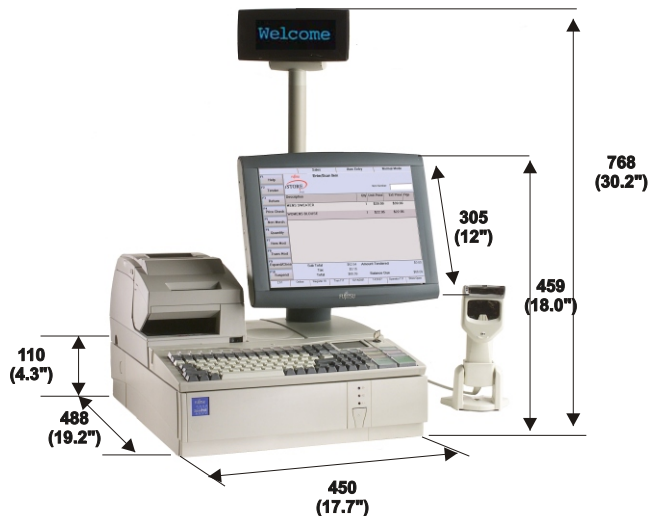

3.2 Compact TeamPoS 2000 12.1" LCD Stacked Configuration Dimensions



3.3 Standard TeamPoS 2000 12.1" LCD Stacked Configuration Dimensions

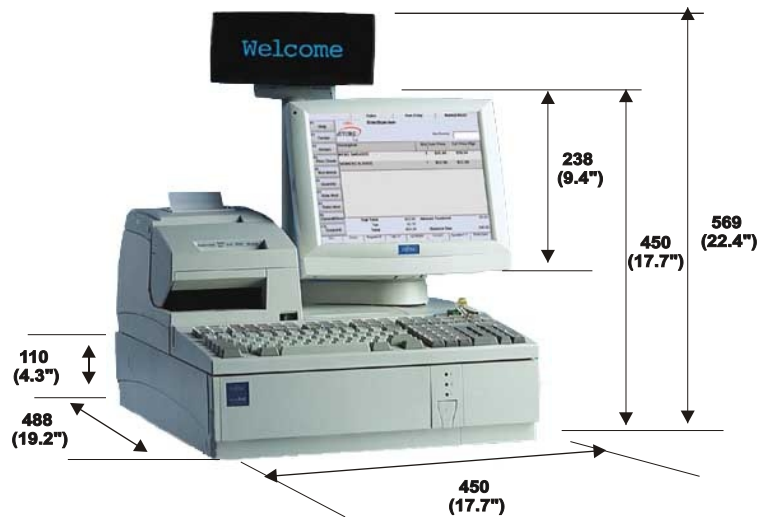

Note:

1. Both standard and compact units above with 12.1" LCD units are shown with long *integrated* customer display poles. The standard unit with 15" LCD on page 3-1 is shown with a long *dispersed* customer display pole. The compact unit does not support the 15" LCD display.
2. See cash drawer dimensions for configurations that include a cash drawer.
3. The 12.1" LCD in the compact configuration (3.2) is shown with speakers, the LCD in the standard configuration (3.3) is shown without the speakers. Please note the one inch dimension difference in the height of the LCD caused by the speakers.

3.4 Control Units

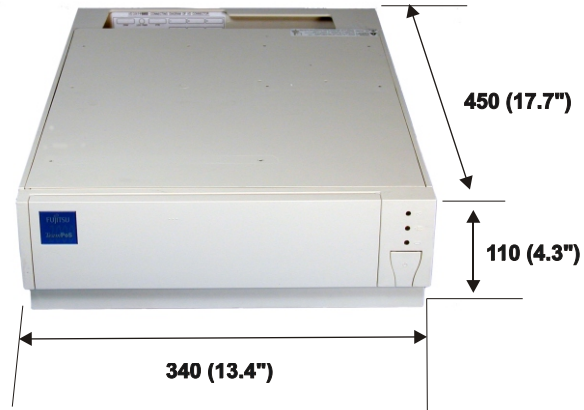

Compact TeamPoS 2000
Control Unit
(See Intelligent PIN # Section 1.3)



Standard TeamPoS 2000
Control Unit
(See Intelligent PIN Section 1.3)

3.5 Keyboards

3.5.1 Model 133UQ Keyboard Dimensions

(PIN #s 90000626-629 [90000629 shown])



3.5.2 Model 104P Keyboard Dimensions

(Pin #90000175)



3.5.3 Model 133PQ Keyboard Dimensions

(PIN #PB600335)



3.5.4 Basic Model 92M and 92U Keyboard Dimensions

(PIN # 53876001M 900000630)

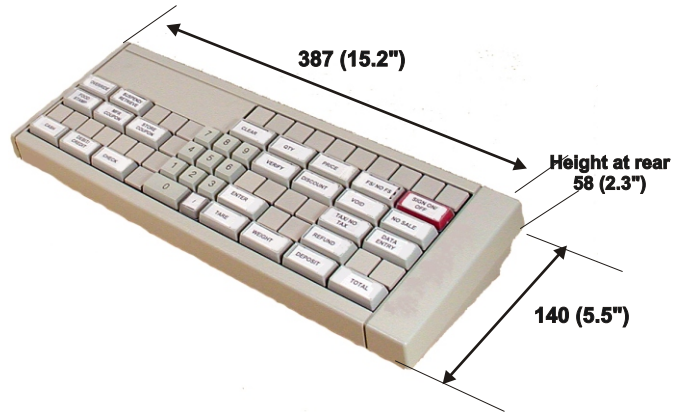

3.5.5 Model 92M & 92U Keyboard with MSR and Display Dimensions

(PIN #s 53876004M- 006M
90000630-32)



3.5.6 Model 92M Keyboard with Vertical Key-Lock Dimensions

(PIN #s 53876005EM, 007M, 008M, 009M, 010EM, 011EM, 012EM)

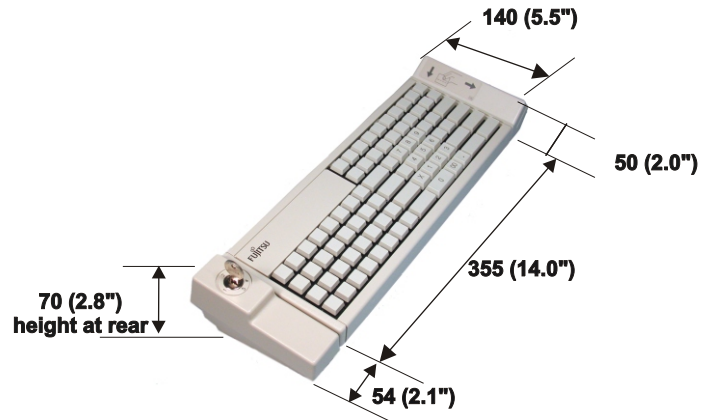

3.6 Cash Drawers

3.6.1 Model TP10 Cash Drawer

(PIN #s 54258001- 003)

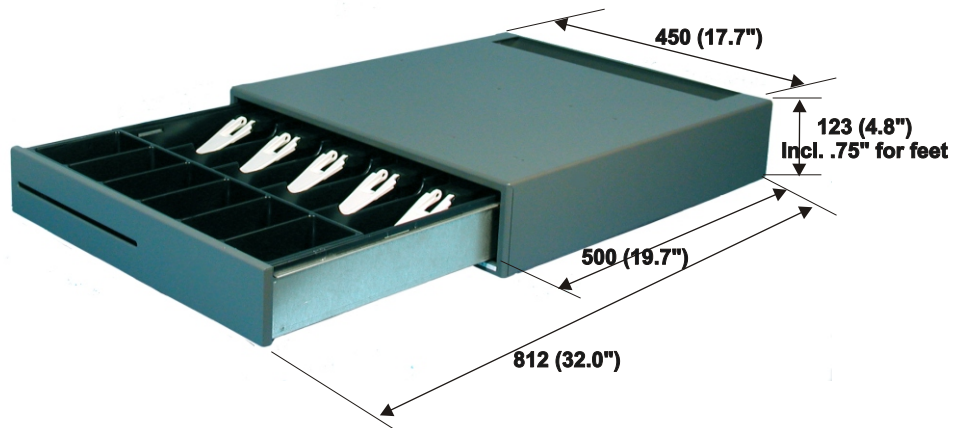

3.6.2 MP5 Cash Drawer, Compact

(PIN #s CA82003-5002 & -5003)

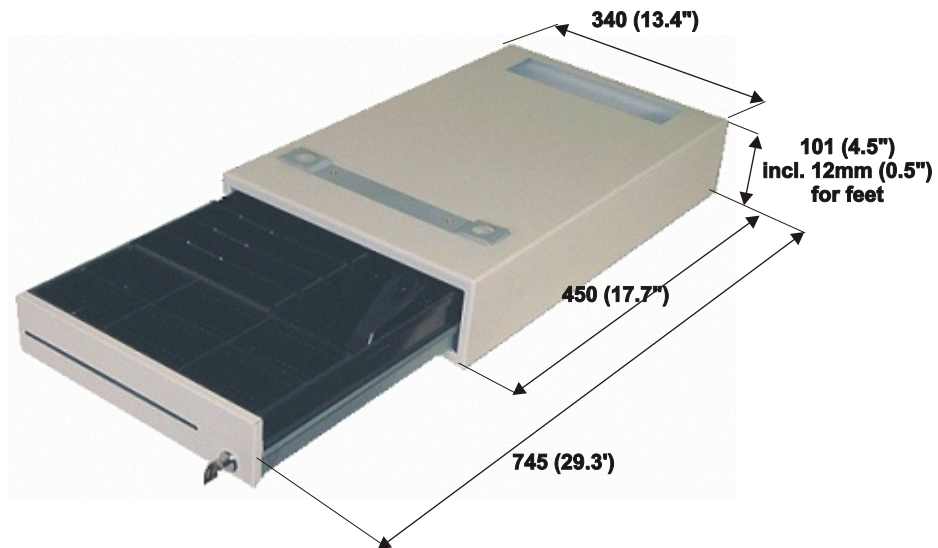

3.6.3 NF5 Cash Drawer

(PIN #s 90000576-577)

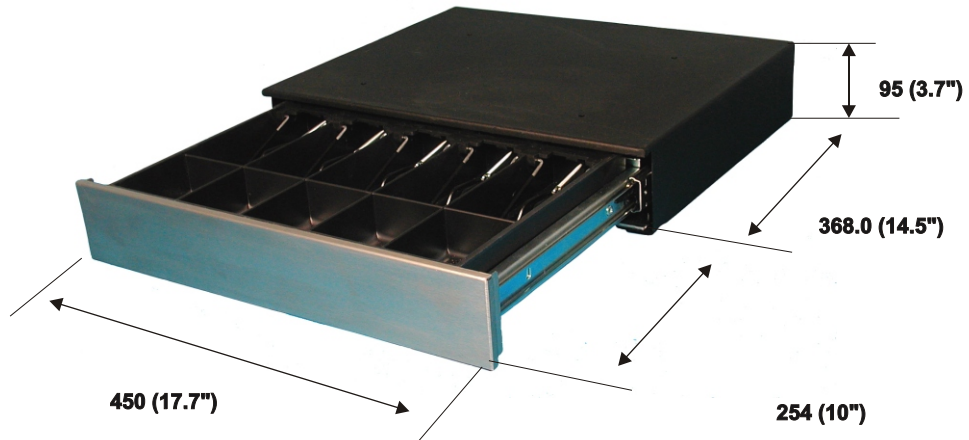

3.6.4 Model NAF Cash Drawer

(PIN #s 4669001-006) (withdrawn)

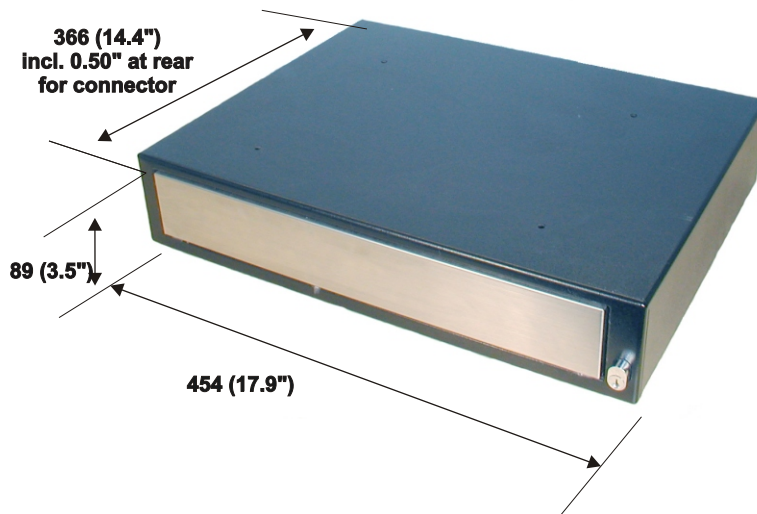

3.7 Displays

3.7.1 Model D15 LCD Displays (*New Release*)

The D15 LCD is a 15" LCD which supports both analog and digital interfaces in the same unit. To use the D15 as an analog device simply connect using a VGA cable. To switch from analog to digital use a DVI cable to connect it to the PoS unit and download video drivers from the following website: <http://us.fujitsu.com/support> then look for the heading Retail PoS Systems. Speakers are standard on the D15.

The D15 comes in non-touch or 5-wire resistive or capacitive touch. Options include a 5x8 keypad and 3-track MSR which can be added either separately or in combination. There are three stand options; stacked (not available for compact TP2K), dispersed and in-counter mount.

(PIN #s 90000820-21,90000855)



3.7.2 LCD Bracket Mounting

The D15 LCD uses a standard 100mm (4") vesa mount..

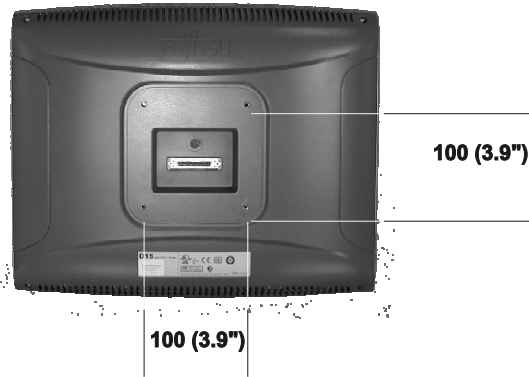

3.7.3 Single Stacked D15 LCD

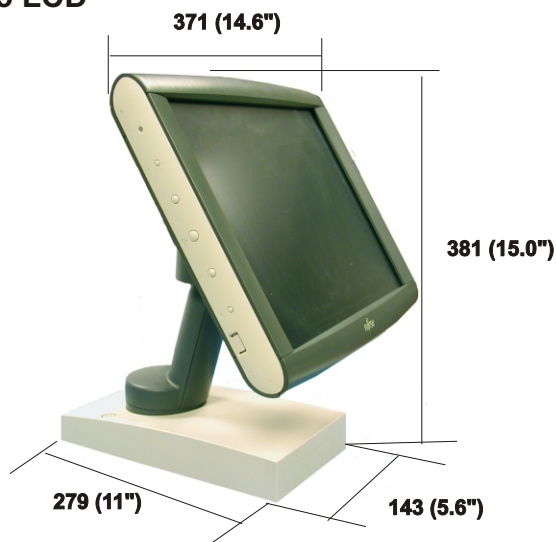

3.7.4 Single Stacked D15 LCD w/customer display

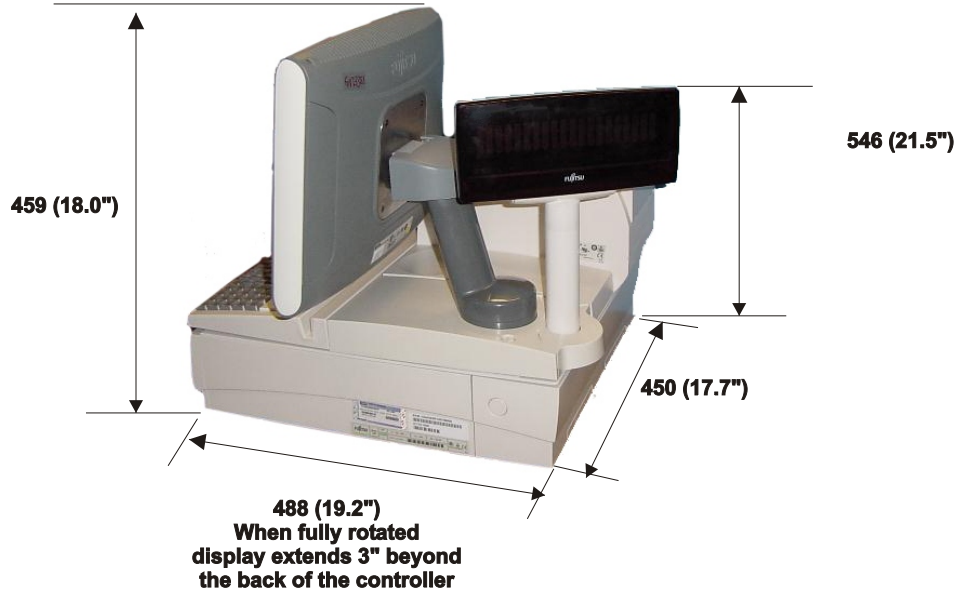

3.7.5 Single Dispersed D15 LCD

(PIN90000820-24, 90000855, 90001127 monitors with 90000823 stand)

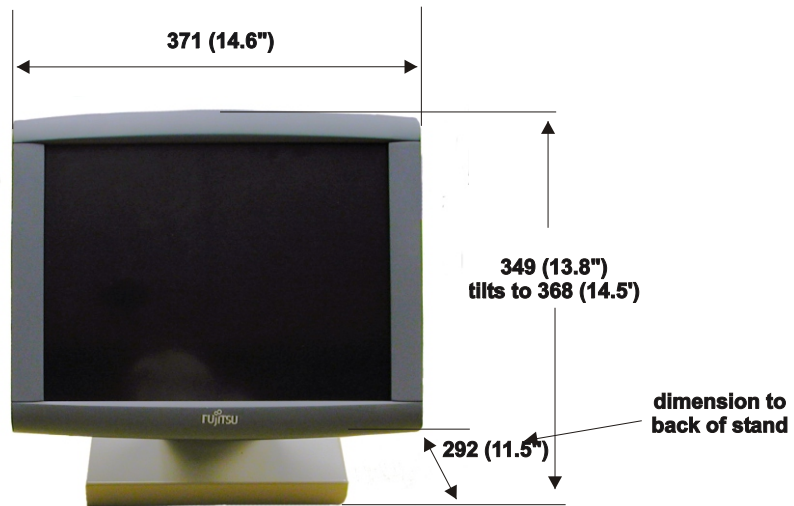

3.7.6 Single Dispersed LCD with MSR

(PIN #'s 90000820, 90000855, 90001127 monitors,
90000823 stand, 90000831 MSR
90000821monitor (withdrawn))

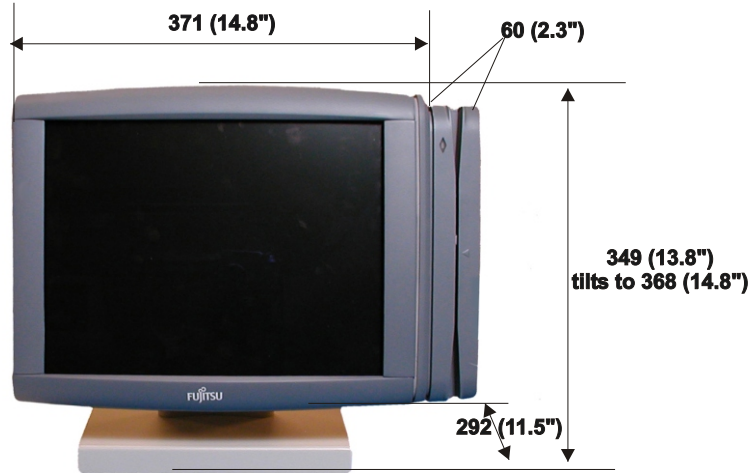

3.7.7 Single Dispersed D15 with Keypad and MSR

(PIN #'s 90000820, 90000855, 90001127 monitors,
90000823 stand, 90000830 (keypad & MSR w/lock)
90000821monitor (withdrawn))

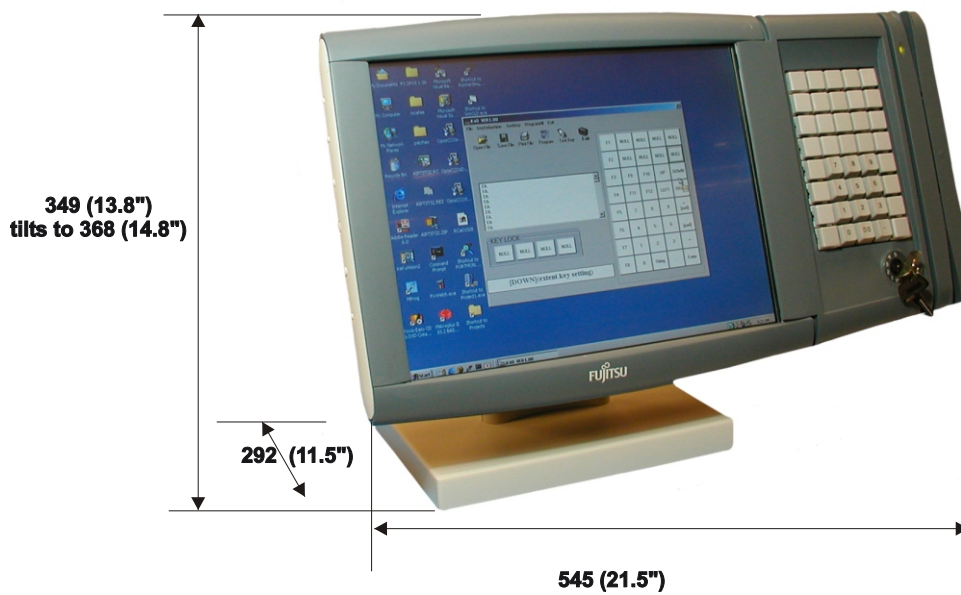

3.8 Models D12 and A12 LCD Displays

The 12.1" LCDs come in six models, with two technologies and two interfaces. The two technologies are DSTN and TFT and the two interfaces are digital and analog. LCDs may have a touch option. Dimensionally, all LCDs are the same (connector panels in the rear of the units are different). Options include touch; speakers (digital interface only); TeamKey®, which adds a keypad, MSR and key lock or MSR only. There are three stand options: stacked, dispersed and kiosk.

(PIN #s 90000167-169 speaker option supported)
(PIN #s 90000361-362, 90000580-581 speaker option not supported)



Note: Speakers are an option on digital interface LCDs only.

3.8.1 LCD Bracket Mounting

The following information is provided for customers who do not use the optional Fujitsu Transaction Solutions Inc. mounting brackets. An optional VESA compliance adapter is also available for mounting in situations that require VESA mounting. The VESA adapter is attached to the LCD using the 4 mounting screws.

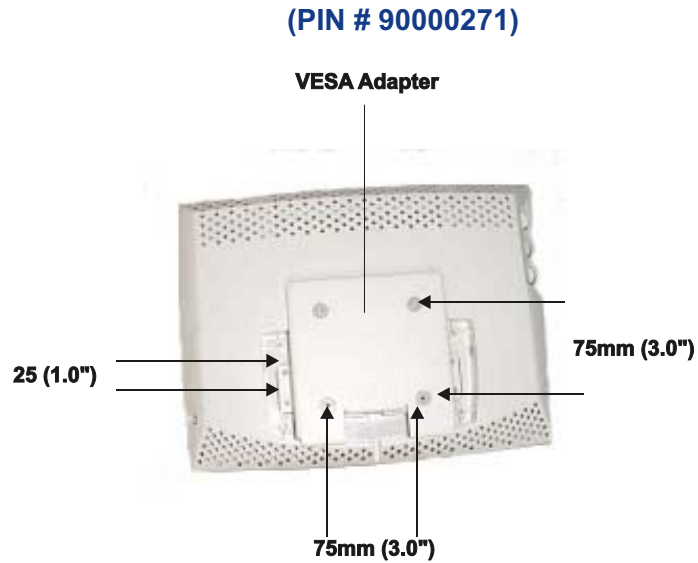

LCD w/VESA Adapter

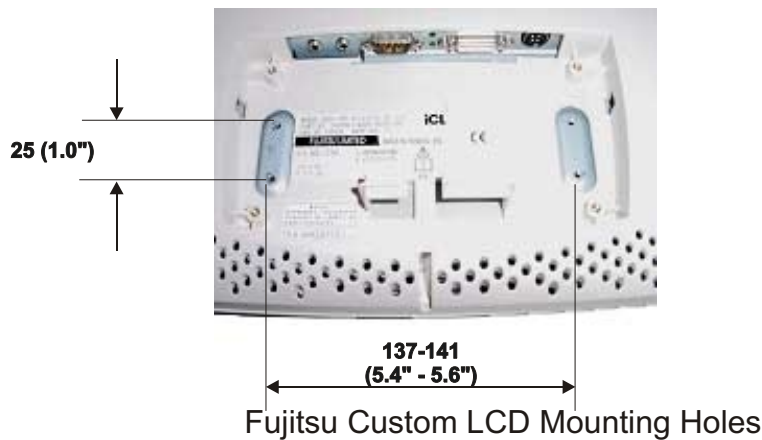

3.8.2 Single Stacked LCD

(all single 12.1" stacked LCDs fit with stand, PIN # 90000162)

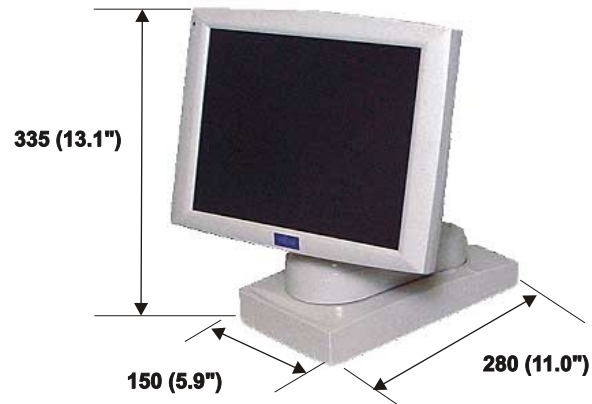

3.8.3 Single Dispersed LCD with dispersed stand

(all single dispersed 12.1" LCDs fit with optional stand, PIN # 90000552)

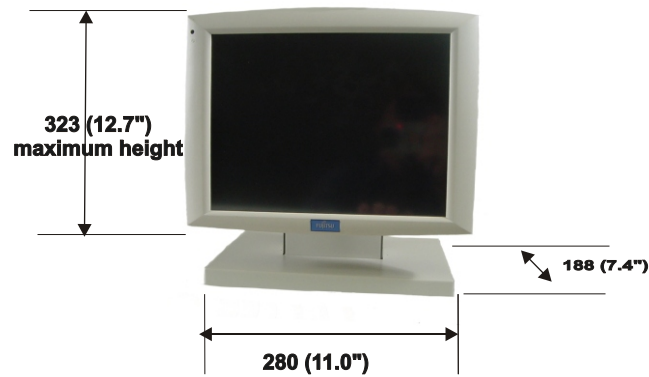

3.8.4 Single Dispersed LCD – Alternate Mount

(alternate dispersed LCD stand fits all single 12.1" LCDs, PIN # 90000171, withdrawn)

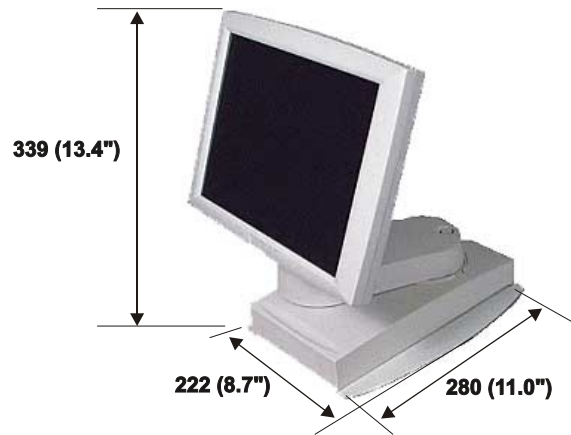

3.8.5 TeamKey

(all 12.1" LCDs fit keypad, PIN #90000354 & dispersed stand, PIN # 90000452)



3.8.6 LCD with MSR (dispersed)

(all 12.1" LCDs fit with MSR, PIN # 90000355 & dispersed stand, PIN # 90000452)

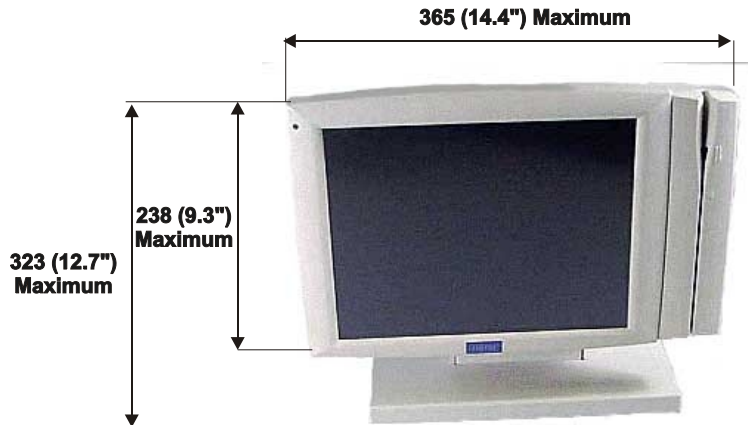

3.8.7 Dual Stacked LCD

(all 12.1" LCDs with stacked stand, PIN # 90000366)

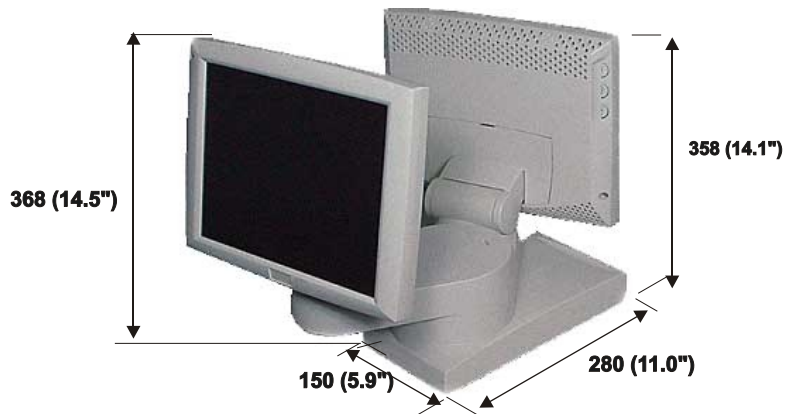

Note: This dual display stand can only be stacked. When the display is stacked it extends 2" beyond the TeamPoS 2000 and 3" beyond the cash drawer at the back of the unit.

3.8.8 Other Options

G Vision (PIN #s L5EX-TA)

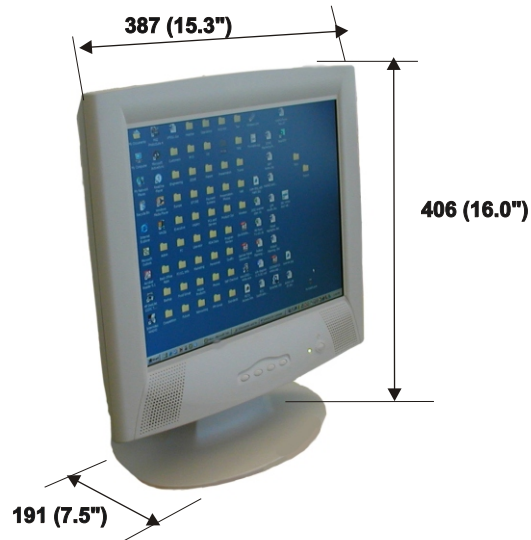

3.8.9 CRTs, 9"

(Active PIN #s 58312001, PB000009
Withdrawn PIN #s PB600440 & 441)

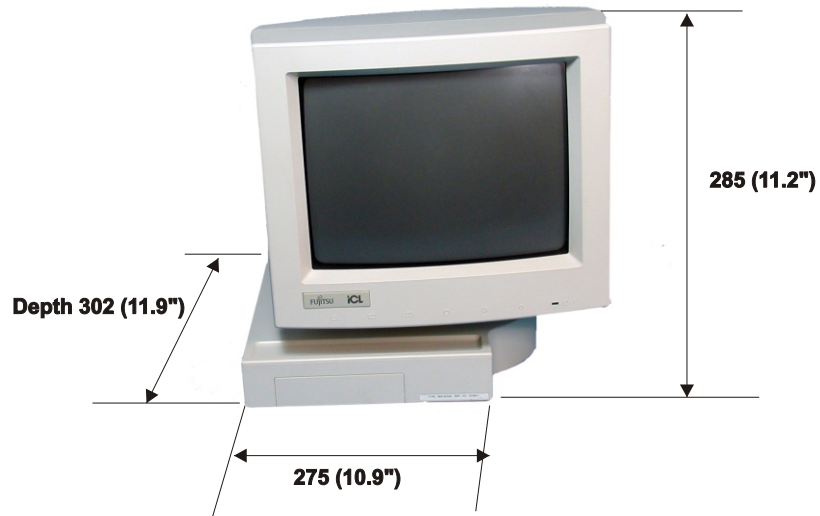

3.8.10 CRT, 14"

(PIN #s 068925-000, 930475-000)

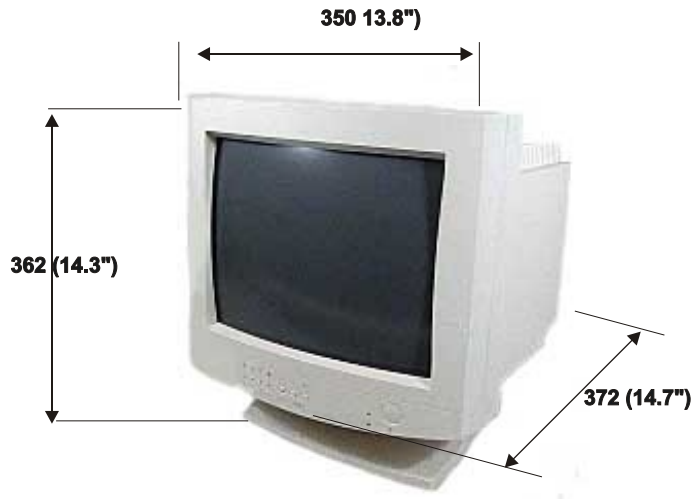

When the 14" CRT Monitor is used in a stacked configuration, a stacking tray is mounted on the control unit to provide support for the monitor and other peripherals (see photo below).

TeamPoS 2000 (Standard only) with Peripherals
Including 14" CRT on Stacking Tray (**PB600307** stacking tray)

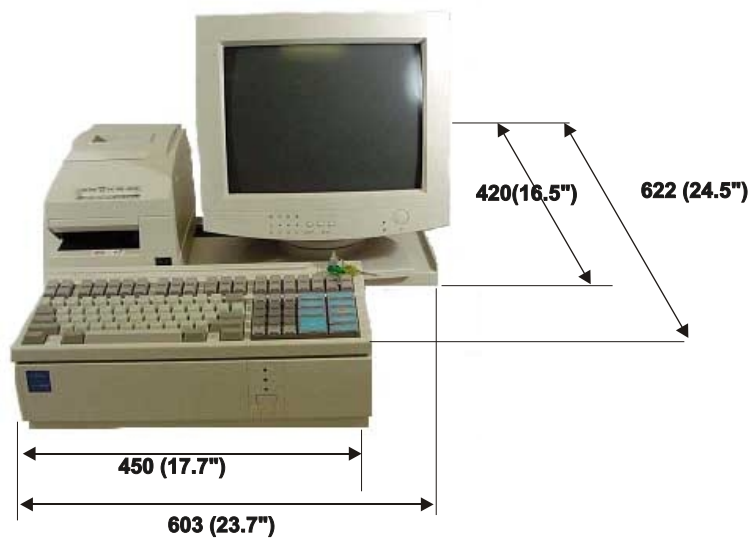

3.8.11 VF50 & VF50U Customer Displays (dispersed configuration)

(VF50 Display, PIN # CA05951-2921; VF50U Display, PIN #KD02902-0171
short pole (0.3 meter) kit, PIN # PB501002;
tall pole (0.6 meter) kit, PIN # PB501003



3.9 Printers

3.9.1 Model DT50/DT50II Printer

(PIN #s 90000048, 90000056-057, 90000541-542
90000772-773)



3.9.2 Model DT50II TranScan Printer

(PIN90000838)

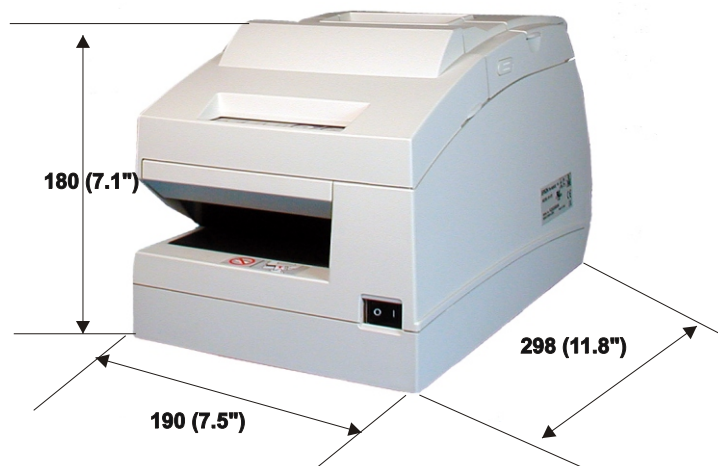

3.9.3 Model TM-T88III Printer

(PIN #90000658)

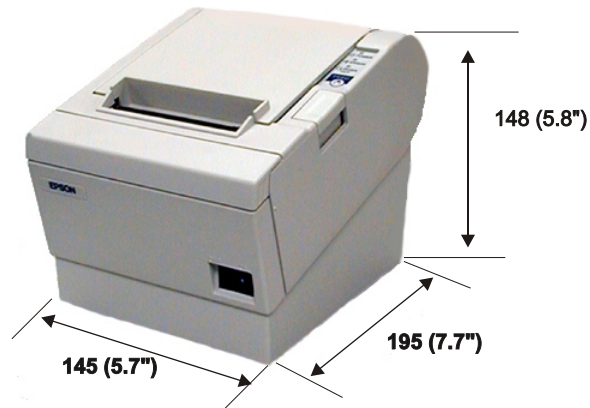

3.9.4 Model TM-T90 Printer

(90000492)

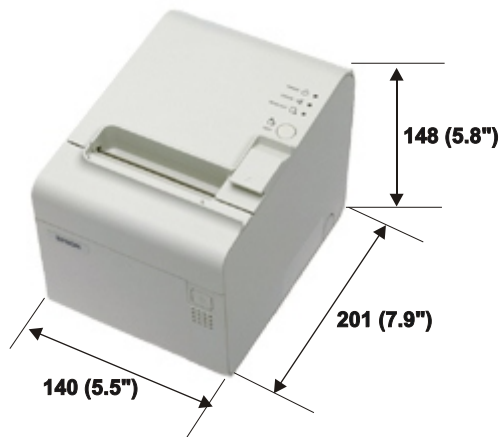

3.9.5 Model A758 & A760 Printers

Dimensions for the A758 and A760 printers are the same.

(A760 - PIN #s 90000697 & 90000755)
(A758 - PIN #s PB600553-556)

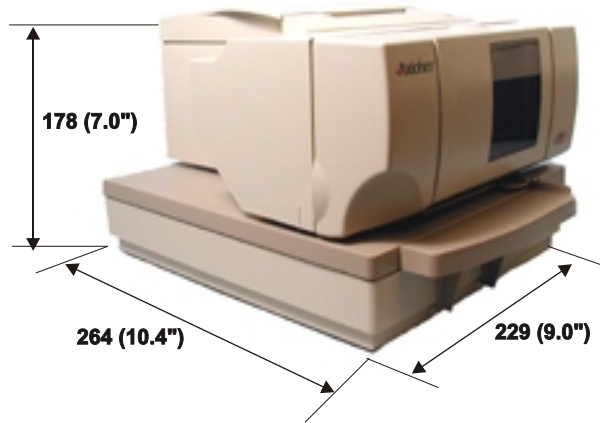

3.9.6 Model A794 Printer

(PIN # PB600557, withdrawn)

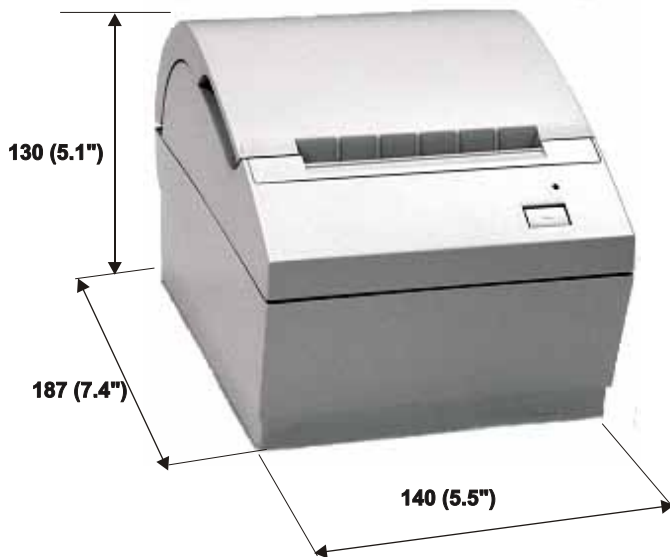

This page intentionally left blank.

Chapter 4 SITE PREPARATION

This chapter defines the following pre-installation details for the TeamPoS Series terminals:

- Shipment inspection and return
- Anti-static protection
- Electrical supply requirements
- Mains power cables

The procedures assume that in-store wiring for the terminals, peripherals, and terminal-to-terminal communications have been installed.

4.1 Unpacking

1. Check delivered components to ensure they match the items listed on the packing list. If components are missing, contact your Help Desk for instructions.
2. Remove the unit and components from the box and check for damage. If the unit or components are damaged, contact your Help Desk for instructions.

4.2 Inspecting the Shipment

The TeamPoS Series terminals are thoroughly inspected prior to shipment; however, damage can occur during transit. Any damage to the terminal can lead to problems after installation. Before accepting a shipment, inspect all shipping containers for external damage. Ensure that all packages listed on the shipment billing form have been delivered. Carefully unwrap and inspect all equipment:

- Check delivered items to ensure that all the items listed on the packing list have been received. Report shortages and damage to CustomerCare. The customer needs to provide the sales order number and a description of the piece of equipment damaged. The customer should then telephone 1-800-780-5525 and a CustomerCare representative will arrange for replacement. CustomerCare is not responsible for equipment damaged by the customer after it is delivered.
- Inspect the exterior of each shipping box noting damage on the shipping documents so that the carrier has a record.
- Inspect the exterior of each unit for any obvious physical damage (scratches or abrasion on painted or display surfaces, or on plastic surfaces) that could have occurred during shipping.
- Damaged equipment received from a source other than Fujitsu Transaction Solutions Inc.'s Foothill Ranch facility should be reported to the sender.

4.3 Reporting Shipment Damage

If any damage is detected, it is both the recipient's and the carrier's responsibility to note the damage. Follow all applicable policies and procedures for notifying the carrier, management, and Fujitsu, for reporting the damage, and for filing damage claims.

Please note that all components are packaged separately. Keep the packaging in case it is necessary to return any of the components.

4.4 Returning Equipment

All returns to the factory must be packed in either the original container or a substitute container of equal strength and durability. Packing material, about 76.0mm (3.0 inches) thick, should surround all protruding edges, switches, and surfaces. Parts shipped in a package separate from the unit must also be repacked and included in the return. Each return must include the following information.

- Description of the equipment defect
- Cause of the defect
- Name, address, and phone number of the person making the return.
- RMA number provided by customer service

4.5 Using Anti-static Protection

When installing and disassembling equipment, be sure to follow anti-static protection procedures. All controllers, terminals, peripherals, and boards are susceptible to damage due to electrostatic discharge. Insufficient anti-static protection when handling boards may cause failures, degraded operation, and reduced reliability.



Caution: Avoid touching connector pins on data cables or units. Touching exposed connector pins could cause a discharge into the circuitry resulting in failed components.

4.6 Preparing for Installation:

Before installing equipment, perform the following steps:

- Move all terminal components, accessories, and cables to the locations specified in your local site plan.
- Position the cables according to the site plan. Make sure you have the correct data cable at each terminal location.
- Place the optional equipment next to the terminal to which it will be connected.
- Remove the shipping tape from those components that have been taped.

4.7 Determining Power Requirements

Electrical power to the equipment must comply with all local, state, and national wiring codes and meet the requirements described here. If you do not have qualified in-house personnel to ensure that power requirements are met, you should hire an electrical contractor familiar with computer equipment. This section provides the electrical supply data and main power cable information to prepare a site for the installation of the TeamPoS 2000 Series terminal.



Caution: To prevent data loss, do not plug other equipment that can produce sudden power surges (for example, vacuum cleaners) into the same power circuit as the terminal.

4.8 General Requirements

The TeamPoS 2000 power supply is autoranging and can be connected to nominal 115VAC or 230VAC power without any adjustments.

The following are general electrical supply requirements:

- Line noise limitations must not exceed 1250V, 1 s duration, 100Hz repetition rate
- Socket outlets must provide protective earthing and be of a polarized type

To properly ground the power lines for the terminal:

- Include a functional (low noise) earth conductor for each branch circuit in the system.

Connect the protective earth through the service equipment.

Before installing the terminal, check the power lines for loads that could cause large variations in voltage. Electrical devices that use a great deal of power such as air conditioners, elevators, copying machines, and large motors can cause large drops in voltage. When severe electrical interference occurs, installing radio frequency (RF) filters, an isolation transformer, or both may be necessary. If voltage surges caused by lightning are likely to occur, install an arrester.

4.9 Installation with Other Equipment

In most cases, dedicated AC mains circuits are not required for the TeamPoS Series terminals. In rare instances, other electrical equipment sharing power with the terminal may cause adverse effects on the terminal. When this occurs, electrical isolation may be required and is the responsibility of the customer or installing contractor.

Terminals at 115-volts

The following table details the electrical supply requirements for the TeamPoS Series control unit with a nominal voltage supply of 115 volts.

| Property | Value or Description |
|---|--|
| Earthing | The terminals are Class 1 equipment and must be supplied via a socket-outlet which has a protective earthing contact connected to the protective earth terminal of the installation. |
| Power System | The terminals are designed for use on a power system with an earthed neutral, i.e., a TN or TT power system according to IEC 364. The terminals must not be directly connected to a power system with an impedance earthed neutral, i.e., an IT power system according to IEC 364. |
| Rated Voltage | 115 Volts |
| Operational Voltage Limits | 100-120 VAC |
| Rated Current | 4.6 A |
| Rated Frequency | 60 Hz |
| Operational Frequency Limits | 57-63 Hz |
| Earth Leakage Current | < 1.0 mA |
| Power Dissipation | 250 watts |
| Maximum HRC Fuse Rating for External Short-circuit Protection | 20 A |
| Main Power Cord: Length | 3.00m (9.80 ft.) |
| Diameter: | 8.0 mm (0.30 in.) |
| Minimum Bend Radius: | 10.0 mm (0.40 in.) |

4.10 Mains Power Cable

Fujitsu supplied cables must be used to connect the system to the power supply outlet. The mains power cables for the TeamPoS Series terminals are terminated with a plug suitable for the ordering country. The following is a list of available power cables:

- U.S./Canada
- Europe
- UK
- Australia/South America
- South Africa

This page intentionally left blank.

Chapter 5 INSTALLATION



Caution: Confirm that the external power source is 100-240 VAC before starting the operation. To prevent electric shock, confirm that the AC cable is removed from the AC outlet anytime the covers are removed. Be sure to observe all ESD precautions and power OFF procedures.

5.1. Cover Removal/Installation Process

In many cases, TeamPoS 2000 control units will be fully configured from the factory or at configuration centers. Others will be configured during installation. This section shows how to access the control unit components to add or change configurations. Accessing the TeamPoS 2000 internal components always requires the removal of the front panel.

5.1.1 Front Cover



Caution: Be sure to observe all ESD precautions and power OFF procedures.

1. Push the upper center (three raised dots) of the front cover to open it. An optional key lock is available for front cover (not shown here).

Push here to open & latch door

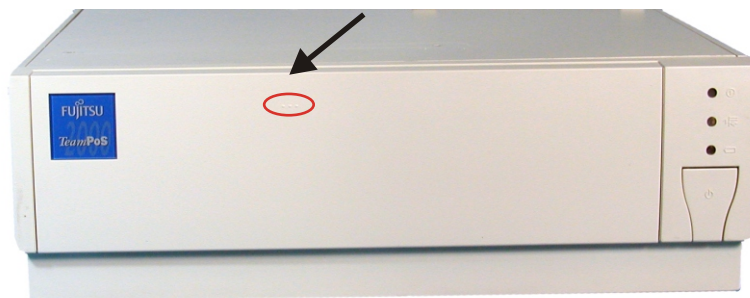

2. Manually loosen the two metal thumbscrews on the right and left to remove the entire front cover. A coin or screwdriver can be used to loosen the thumbscrews if they are too tight.

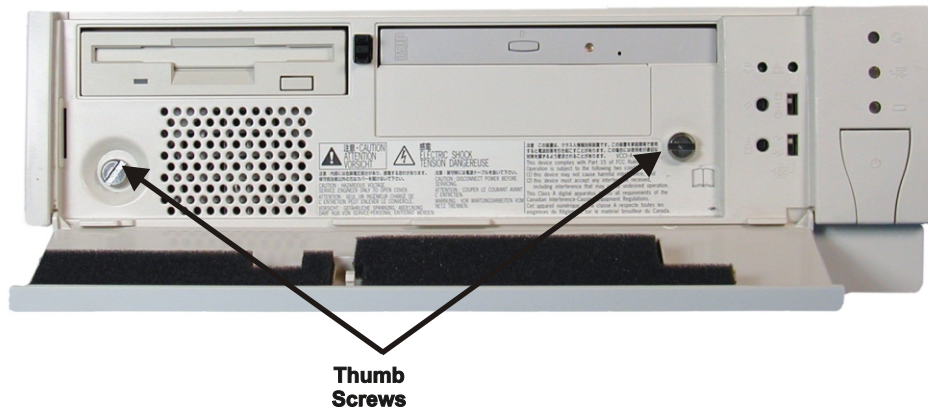

5.1.2 Side Cover (Left)



Caution: Be sure to observe all ESD precautions and power OFF procedures.

1. Remove the front cover (see 5.1.1).
2. While facing the front of the device, first pull the left side cover slightly forward (in the direction indicated by the arrow) to remove the side cover..



3. To mount the side cover again, first insert the tab at the lower back of the cover into the hole in the cabinet, insert the remaining tabs, and then slide cover to the rear.



5.1.3 Rear Cover

1. While facing the back of the device, push the buttons on the right and left side to remove the rear cover.



Note: To mount the rear cover again, first hook the cover over the tab on the left side, and then close the right side.



Caution: Be sure to observe all ESD precautions and power OFF procedures.

5.1.4 Top Cover

1. Lift the keyboard, and then disconnect the cable from the bottom to remove the keyboard.



2. Remove the rear cover (see section 5.1.3).
3. Disconnect LCD, VFD (Customer Display unit) and printer cables.



4. Slide the pedestal with the LCD and the Customer Display (if installed) slightly toward the front, then lift and remove the pedestal.



5. Remove the printer in the same manner.
6. Remove front cover (see section 5.1.1)

7. Slightly pull the top cover toward the front (in the direction indicated by the arrow), then lift and remove the cover.

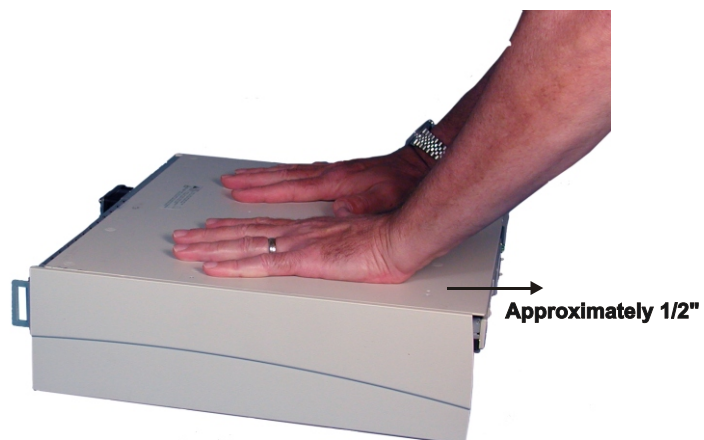

8. To mount the top cover again, reverse the removal procedure.

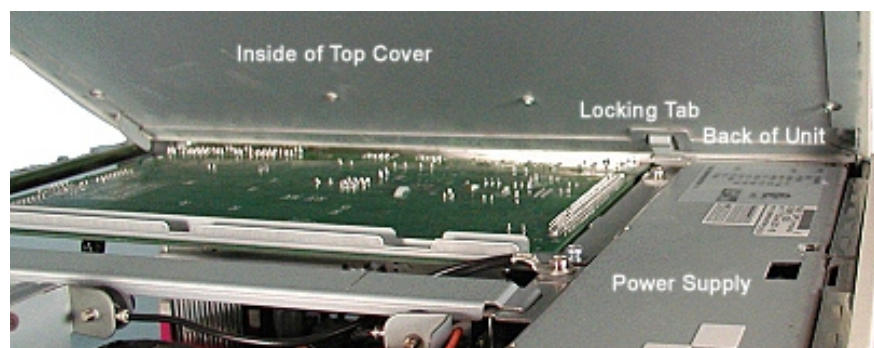

Note: There is a locking tab on the inside of the top cover. Ensure that the tab on the back of the top cover goes under the chassis prior to pushing it into place.

5.1.5 Installing D12 and A12 LCD Brackets

5.1.5.1 Installing keyboard, printer, CRT and LCD brackets

For stacked configurations, keyboard, printer and operator display brackets are available. The brackets attach to the top of the control unit and restrain the peripherals from sliding. The following table shows available brackets for the compact and standard control units: When installing peripheral brackets, install each bracket using two screws that have been provided with the bracket. For most installations, a keyboard, printer and display bracket will be required.

Note: See bracket options in Chapter 10 for part numbers.

| Bracket | Compact | Standard | Mutually exclusive with | Comments |
|-----------------------------|---------|----------|----------------------------|---|
| Keyboard | Yes | Yes | | Fits Models 133UQ, 133PQ, 136P and 104P keyboards |
| FD20/21 Printer | No | Yes | All other printer brackets | |
| Axiom A758 Printer | No | Yes | All other printer brackets | |
| DT50/DT50II/DT50IIT Printer | Yes | Yes | All other printer brackets | When stacking the DT50/DT50II/DT50IIT and a D12/A12 LCD on a standard unit, a filler and shorter connector cover are optional |
| D12/A12 LCD | Yes | Yes | CRT | |
| CRT | Yes | Yes | LCD | |

Note: When installing mounting screws, do not over-tighten.

Installing the brackets merely requires placing the bracket on the appropriate screw holes and securing with two screws provided for each bracket. To prevent dust and moisture penetration, apply a screw-hole cover label from the provided label sheet over each screw

hole on the top cover where a bracket will not be used. For dispersed configurations, all holes are covered.

5.1.5.2 D12 and A12 Stacking Bracket Locations

The following shows peripheral bracket locations on the compact and standard control units. If a D12/A12 LCD and model DT50/DT50II printer are installed on a standard unit, a filler occupies the remaining space. See next section.

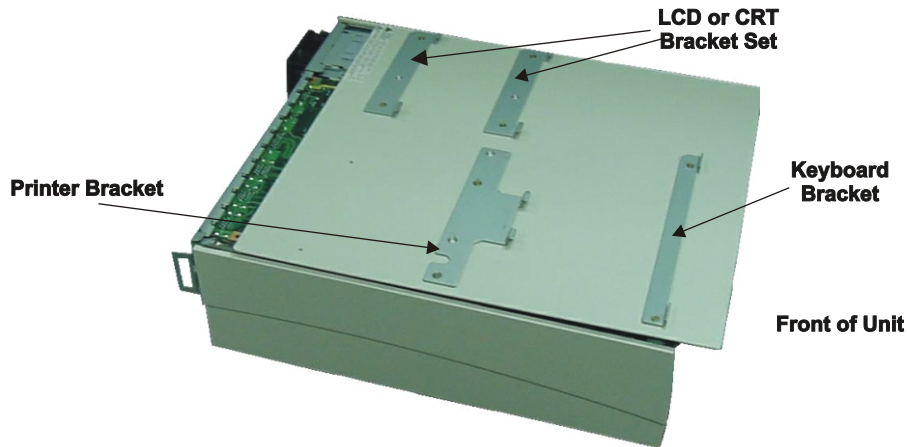

Compact Unit

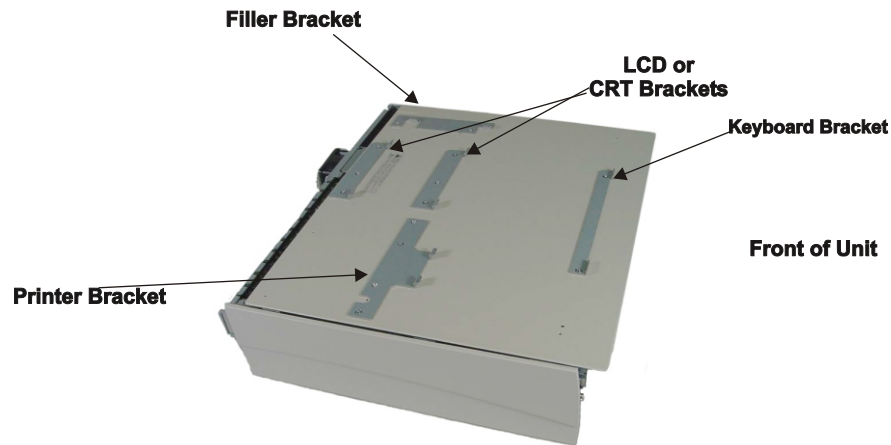

Standard Unit

5.1.5.3 Filler Unit Installation on a Standard Unit

The filler is used to occupy the free space on a standard control unit with a stacked LCD (either 12.1" or 15") and model DT50/DT50II printer. An optional connector cover (not

shown) is also available that makes the connector cover flush with the peripherals. The standard connector cover protrudes slightly beyond the peripherals if an LCD and model DT50/DT50II printer are selected.

1. Attach filler bracket to top cover of unit with bracket hooks facing inward. Secure with two screws.

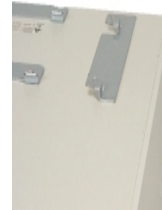

Right side of control unit when facing the front panel

2. Slide filler part onto bracket.



3. Stack display only after filler part has been fixed to bracket.



4. Stack DT50/DT50II printer and model 133PQ keyboard after the display has been stacked.





Caution: Be sure to observe all ESD precautions and power OFF procedures

5.1.6 PCI Add-In Card(s)

1. Remove the front cover (See section 5.1.1).
2. Remove the side cover (left) (See section 5.1.2).
3. Remove top cover (See section 5.1.4).
4. Remove the Retail I/O Board, TeamCOMBO or TeamUSB board (see section 7.12).

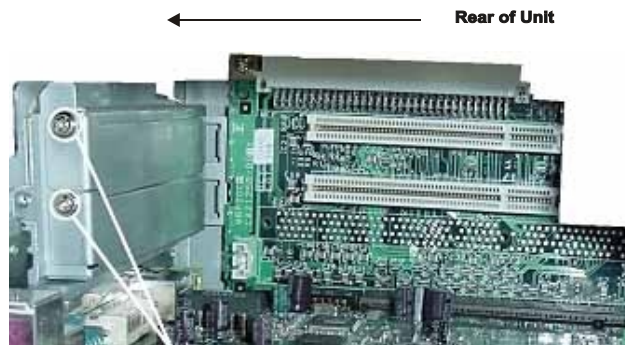

**Screws for securing the PCI
Add-in Card/Blanking Plate
(viewed from left side of unit)**

5. Remove the PC card blanking plate by removing one screw.
6. Install an add-in card.
7. Secure add-in card with the screw that was holding the blanking plate.
8. Reverse steps 1 to 4.

5.2 Adding Main Memory

5.2.1 Memory Configuration



Note: Up to two PCI add-in cards can be installed.

5.2.1.1 Pentium III Motherboard

Any combination of 64, 128, and 256MB DIMMs can be installed in any of the three sockets on the motherboard, allowing from 64MB to 768MB memory. In the maintenance section of this document, see Memory (DIMM), section 7.10, for the correct procedure for installing memory.

5.2.1.2 Memory Configuration M Motherboard

Pentium M has two memory slots and comes in combinations of 256MB, 512MB and 1GB (future release, for a maximum of 2GB).

Note: When adding memory, ensure that the upgrade label that comes with the memory is applied to the side of the control unit.

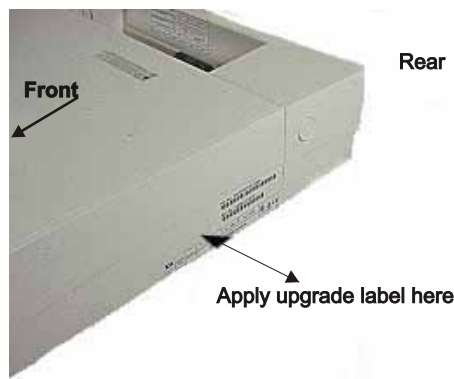

5.3 Accessing and Configuring

(PIN # 90000161)



5.3.1 Retail I/O Board Pin layout

To access jumpers:

1. Remove front cover (see section 5.1.1).
2. Remove side cover (left) (see section 5.1.2).

Retail I/O Board Layout

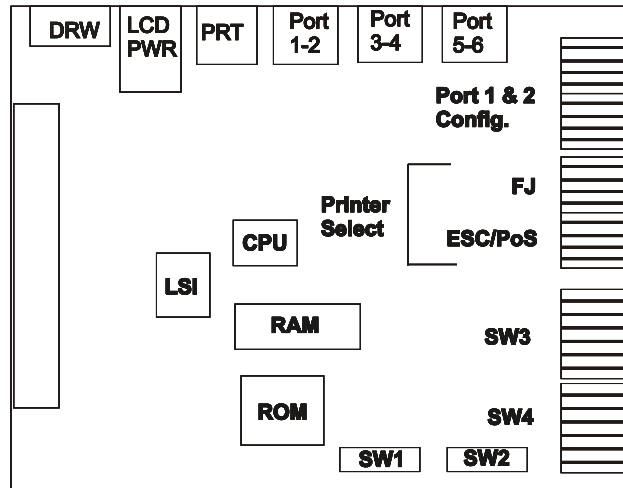

5.3.2 Retail I/O Board Settings

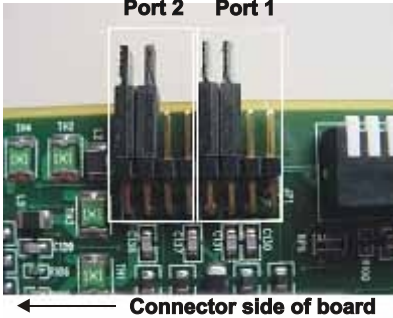
| Switch | Definition | Settings (Default in Bold) | | | |
|---|---|----------------------------|---------------|-------------------|------------------|
| Port 1/2 | DC Powered or Standard COM-I/F for Port 1/2 | PORT 1 | STD COM | DC Powered | |
| | | PORT 2 | STD COM | DC Powered | |
| <p>* Two jumpers required for each setting.</p> <div style="display: flex; align-items: center;">  <div style="margin-left: 10px;"> <p>Move both jumpers to pins on right for Std COM</p> </div> </div> | | | | | |
| SW3 | | | | | |
| 1 | UART Base Address in MCP Mode | ON | 0230H | OFF | 0100H |
| 2 | OPC/MPC Parallel Port Address | ON | 0278H | OFF | 0378H |
| 3 | MODE Operation Mode | ON | OPC | OFF | MCP |
| 4 | MODE Operation Mode | ON | COM3/4 | OFF | Multi-Com |
| 5 | BATL Detect Lead Acid Battery Alarm | ON | Enable | OFF | Disable |
| 6 | FAN1 Detect CPU FAN Alarm | ON | Enable | OFF | Disable |
| 7 | FAN2 Detect PSU FAN Alarm | ON | Enable | OFF | Disable |
| 8 | FAN3 Detect Chassis FAN Alarm | ON | Enable | OFF | Disable |
| SW4 | | | | | |
| 1 | Factory use only. Must be off | ON | Enable | OFF | Disable |
| 2 | Factory use only. Must be off | ON | Enable | OFF | Disable |
| 3 | IRQ12 S | ON | Enable | OFF | Disable |
| 4 | IRQ11 E O O | ON | Enable | OFF | Disable |
| 5 | IRQ10 L N N | ON | Enable | OFF | Disable |
| 6 | IRQ9 E L E | ON | Enable | OFF | Disable |
| 7 | IRQ7 C Y | ON | Enable | OFF | Disable |
| 8 | IRQ5 T | ON | Enable | OFF | Disable |

| Switch | Definition | Settings (Default in Bold) |
|--------|---|--|
| SW1 | COM3 IRQ Only one IRQ switch can be ON Note: Only applies when SW 3, position 4 is set for COM 3/4 | IRQ3 OFF IRQ10 OFF IRQ4 ON IRQ11 OFF IRQ9 OFF IRQ12 OFF |
| SW2 | COM4 IRQ Only one IRQ switch can be ON Note: Only applies when SW 3, position 4 is set for COM 3/4 | IRQ3 ON IRQ10 OFF IRQ4 OFF IRQ11 OFF IRQ9 OFF IRQ12 OFF |

5.3.3 Printer Jumpers

There are two printer jumper connectors, one is FJ and used for the models FD20 and FD21 printers. The other is ESC/POS (default) and is used for all other supported printers. Depending on the printer being connected, place the jumper block so that all pins on the appropriate connector are shorted

| | FJ | ESC/POS |
|-------|----------|---------|
| Mux12 | +5V | RTS |
| Mux11 | +5V | DTR |
| Mux9 | Not used | RI |
| Mux6 | Not used | CD |
| Mux5 | GND | DSR |
| Mux4 | GND | CTS |
| Mux1 | RESET | GND |

The following tables contain the connector signals for the ports on the Retail I/O Board. A diagram of each connector and its pin out locations is shown after each table.

5.3.4 PTR (Printer) Connector Signals

Connector type: Female D15, (See section 5.3.1 for locations.)

Note: Pin outs may differ depending on jumper placement, see section 5.3.3.

| Pin # | Signal FD20 Mode (Fujitsu printer signals) | Signal ESC/PoS Mode (Epson printer signals) |
|-------|--|---|
| 1 | Reset (TTL) | GND |
| 2 | RX | RX |
| 3 | TX | TX |
| 4 | GND | CTS |
| 5 | GND | DSR |
| 6 | Not used | CD |
| 7 | GND | SG |
| 8 | +24V RET | 24 V RET |
| 9 | Not used | RI |
| 10 | +5V | +5V |
| 11 | +5V | DTR |
| 12 | +5V | RTS |
| 13 | +24V RET | GND |
| 14 | +24V | +24V |
| 15 | +24V | +24V |

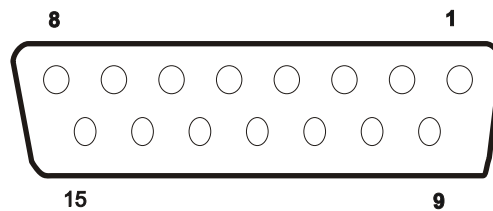

5.3.5 Retail I/O Board. Ports 1 and 2 Connector Signals

Connector type: Male D9, (RS-232 ports) (See section 5.3.1 for locations.)

| Pin # | Signal when DC Powered Mode | Signal when Standard Com Mode |
|-------|--------------------------------|----------------------------------|
| 1 | NC | CD |
| 2 | RX | RX |
| 3 | TX | TX |
| 4 | DTR | DTR |
| 5 | SG | SG |
| 6 | DSR | DSR |
| 7 | RTS | RTS |
| 8 | CTS | CTS |
| 9 | +5V | RI |

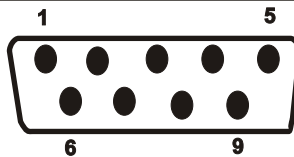

5.3.6 Retail I/O Board.Port 5 Connector Signals

Connector type: Male D9 (RS-232 ports)

| Pin # | Signal |
|-------|--------|
| 1 | NC |
| 2 | RX |
| 3 | TX |
| 4 | DTR |
| 5 | SG |
| 6 | DSR |
| 7 | RTS |
| 8 | CTS |
| 9 | +5V |

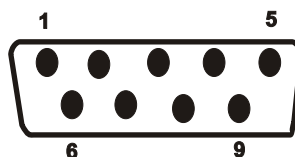

5.3.7 Retail I/O BoardPorts 3, 4 & 6 Connector Signals

Connector type: Female D9

| Pin # | Signal |
|-------|--------|
| 1 | GND |
| 2 | RX |
| 3 | TX |
| 4 | +24V |
| 5 | SG |
| 6 | +5V |
| 7 | RTS |
| 8 | CTS |
| 9 | GND |

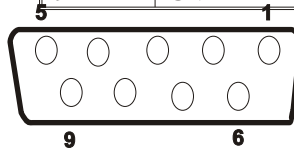

5.3.8 DRW Connector Signals

(Cash drawer port) Connector type: Female D9

| Pin # | Signal |
|-------|------------|
| 1 | +24V RET |
| 2 | CD1 Status |
| 3 | CD1 SOL+ |
| 4 | NC |
| 5 | GND |
| 6 | NC |
| 7 | CD2 SOL+ |
| 8 | CD2 Status |
| 9 | GND |

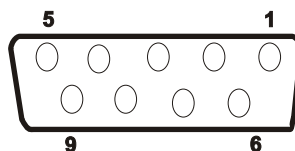

5.4 Installing the TeamCOMBO Board

(PIN #90000273)



5.4.1 TeamCOMBO Board Pin Layout

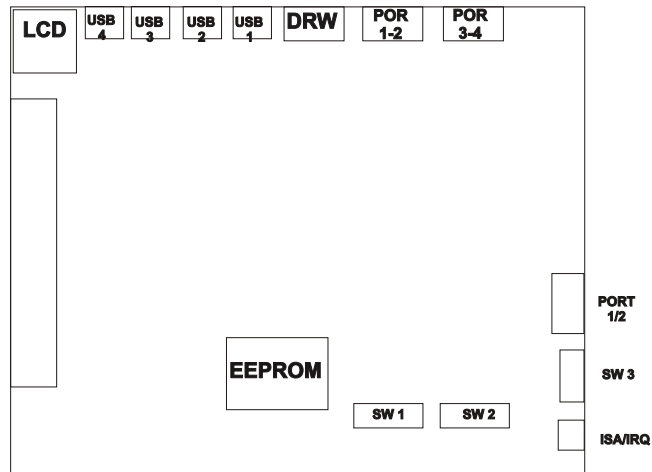

To access jumpers:

1. Remove front cover (see section 5.1.1).
2. Remove side cover (left) (see section 5.1.2).

5.4.2 TeamCOMBO Board Settings

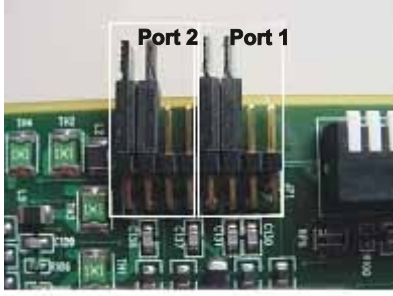
| Switch | Definition | Settings (Default in Bold) | | | |
|----------|---|----------------------------|---------------|-------------------|------------------|
| Port 1/2 | DC Powered or Standard COM-I/F for Port 1/2 | PORT 1 | STD COM | DC Powered | |
| | | PORT 2 | STD COM | DC Powered | |
| | <p>* Two jumpers required for each setting.</p> <div style="display: flex; align-items: center;">  <div style="margin-left: 10px;"> <p>Move both jumpers to pins on right for Std COM</p> </div> </div> <p style="text-align: center;">← Connector side of board</p> | | | | |
| SW3 | UART Base Address in MCP Mode | ON | 0230H | OFF | 0100H |
| 1 | | | | | |
| 2 | Parallel Port Address | ON | 0278H | OFF | 0378H |
| 3 | Mode (Must be set to off) | ON | N/A | OFF | MCP |
| 4 | COM COM Port Mode | ON | COM 3/4 | OFF | Multi-Com |
| 5 | BATL Detect Lead Acid Battery Alarm | ON | Enable | OFF | Disable |
| 6 | FAN1 Detect CPU Fan Alarm | ON | Enable | OFF | Disable |
| 7 | FAN 2 Detect PSU FAN Alarm | ON | Enable | OFF | Disalbe |
| 8 | FAN3 Detect Chassis FAN Alarm | ON | Enable | OFF | Disable |
| ISA/IRQ | IRQ12 S | ON | Enable | OFF | Disable |
| | IRQ11 E O O | ON | Enable | OFF | Disable |
| | IRQ10 L N N | ON | Enable | OFF | Disable |
| | IRQ9 E L E | ON | Enable | OFF | Disable |
| | IRQ7 C Y | ON | Enable | OFF | Disable |
| | IRQ5 T | ON | Enable | OFF | Disable |
| SW1 | COM3 IRQ Only one IRQ switch can be ON Note: Only applies when SW3 position 4 is set for COM 3/4 | IRQ3 | OFF | IRQ10 | OFF |
| | | IRQ4 | ON | IRQ11 | OFF |
| | | IRQ9 | OFF | IRQ12 | OFF |
| SW2 | COM4 IRQ Only one IRQ switch can be ON Note: Only applies when SW3, position 4 is set for COM 3/4 | IRQ3 | ON | IRQ10 | OFF |
| | | IRQ4 | OFF | IRQ11 | OFF |
| | | IRQ9 | OFF | IRQ12 | OFF |

The following tables contain the connector signals for the ports on the *TeamCOMBO* Board. A diagram of each connector and its pin out locations is shown after each table.

5.4.3 TeamCOMBO Board. Ports 1 and 2 Connector Signals

Note: Pin outs may differ depending on jumper placement, see section 5.4.2.

Connector type: Male D9

| PIN # | Signal When DCT Power Mode | Signal when Standard Com Mode |
|-------|-------------------------------|-------------------------------------|
| 1 | NC | CD |
| 2 | RX | RX |
| 3 | TX | TX |
| 4 | DTR | DTR |
| 5 | SG | SG |
| 6 | DSR | DSR |
| 7 | RTS | RTS |
| 8 | CTS | CTS |
| 9 | +5V | RI |

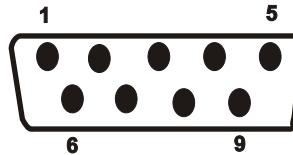

5.4.4 TeamCOMBO Board. Ports 3 and 4 Connector Signals

Connector type: Female D9

| Pin # | Signal |
|-------|--------|
| 1 | GRD |
| 2 | RX |
| 3 | TX |
| 4 | +24V |
| 5 | SG |
| 6 | +5V |
| 7 | RTS |
| 8 | CTS |
| 9 | GND |

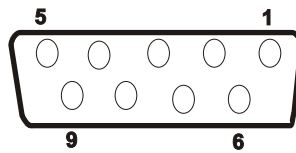

5.4.5 DRW Connector Signals

Connector type: Female D9 (Cash drawer port)

| Pin # | Signal |
|-------|------------|
| 1 | +24V RET |
| 2 | CD1 Status |
| 3 | CD1 SOL+ |
| 4 | NC |
| 5 | GND |
| 6 | NC |
| 7 | CD2 SOL+ |
| 8 | CD2 Status |
| 9 | GND |

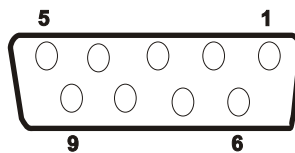

5.4.6 TeamCOMBO Board. USB Connectors – 4 Ports

Powered Retail USB connector (24 VDC or 12 VDC)

| Pin # | DC-Out Mode | |
|-------|---|---------------------------|
| 1 | 5 VDC USB Power | Std. USB Signals |
| 2 | Data - | |
| 3 | Data + | |
| 4 | Ground | |
| 5 | 24 VDC Return, USB ports 1,2, and 3 12 VDC Return, USB port 4 | 12 or 24 VDC Power |
| 6 | 24 VDC Power, USB ports 1, 2 and 3 12 VDC Power, USB port 4 | |
| 7 | 24 VDC Power, USB ports 1, 2 and 3 12 VDC Power, USB port 4 | |
| 8 | 24 VDC Return, USB ports 1, 2 and 3 12 VDC Returnr, USB port 4 | |

Note: The powered USB connector will also accommodate a standard USB connector,.that is pins 1-4. (Top portion of the connector)

5.5 TeamUSB Settings

| Switch | Definition | Settings (Default in Bold) |
|--------|---|--|
| SW1 | 1 BATL Detect Lead Acid Battery Alarm 2 FAN1 Detect CPU Fan Alarm 3 FAN2 Detect PSU Fan Alarm 4 FAN3 Detect Chassis Fan Alarm | ON Enable OFF Disable ON Enable OFF Disable ON Enable OFF Disable ON Enable OFF Disable |
| JP1 | 1-2 Configured for setting up TeamUSB board for 3-4 using six or seven USB ports depending upon 5-6 the motherboard being used. 7-8 9-10 11-12 13-14 15-16 17-18 19-20 | See silkscreen on board for actual jumper settings. |
| JP2 | 1-2 Decodes each drawer open switch from cash 3-4 drawer. Configured for the type of cash 5-6 drawer being used. Distinguishes between FJ 7-8 cash drawer and NCR. FJ is default 9-10 | SHORT FJ OPEN NCR OPEN FJ SHORT NCR OPEN FJ SHORT NCR OPEN FJ SHORT NCR SHORT FJ OPEN NCR |
| JP3 | 1-2 Determines the power source for the +12V on 3-4 USB port 6. Options are from +24V power 5-6 through a DC-DC converter or directly from 7-8 +12V power 9-10 | SHORT +12V OPEN DC-DC SHORT +12V OPEN DC-DC OPEN +12V SHORT DC-DC OPEN +12V SHORT DC-DC OPEN +12V SHORT DC-DC |

5.5.1 TeamUSB Board. USB Connectors - 7 Ports

The TeamUSB board can only be used with the new riser card (Pin #KD20033-B41X). When using the TeamUSB with the Pentium III motherboard, one of the USB ports on the motherboard is used to connect the I/O board and a label covers one of the USB connectors.

| Pin # | DC-Out Mode | |
|-------|---|---------------------------|
| 1 | 5 VDC USB Power | Std. USB Signals |
| 2 | Data - | |
| 3 | Data + | |
| 4 | Ground | |
| 5 | 24 VDC Return, USB ports 1, 2, 3 and 4 12 VDC Return, USB port 5, 6 & 7 | 12 or 24 VDC Power |
| 6 | 24 VDC Power, USB ports 1, 2, 3 and 4 12 VDC Power, USB port 5, 6 & 7 | |
| 7 | 24 VDC Power, USB ports 1, 2, 3 and 4 12 VDC Power, USB port 5, 6 & 7 | |
| 8 | 24 VDC Return, USB ports 1, 2, 3 and 4 12 VDC Returnr, USB port 5, 6 & 7 | |

Note: There are two riser cards: Pin #CA21259-B21X supports Retail I/O and TeamCOMBO options only, PIN #KD20033-B41X supports all I/O Boards.

5.5.2 TeamUSB Board DRW Connector Signals

Connector type: Female D9 (Cash drawer port)

| Pin # | Signal |
|-------|-------------|
| 1 | +24V Return |
| 2 | CD0-Open |
| 3 | CD0-Sol |
| 4 | N/C |
| 5 | Gnd |
| 6 | N/C |
| 7 | CD1-Sol |
| 8 | CD1-Open |
| 9 | +24V Return |

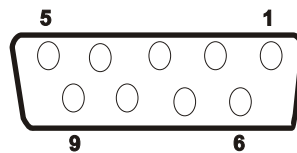

5.5.3 TeamUSB Board, Powered USB Connectors - 7 ports

| Pin # | USB +24V | USB +12V |
|-------|-------------------|----------------|
| | Ports 1, 2, 3 & 4 | Ports 5, 6 & 7 |
| 1 | 5V USB Pwr | 5V USB Pwr |
| 2 | Data - | Data - |
| 3 | Data + | Data + |
| 4 | Gnd | Gnd |
| 5 | +24V Return | +12V Return |
| 6 | +24V Pwr | +12V Pwr |
| 7* | +24V Pwr | +12V Pwr |
| 8 | +24V Return | +12V Return |

* Port 7 is unavailable when TeamUSB board is installed with the A Motherboard

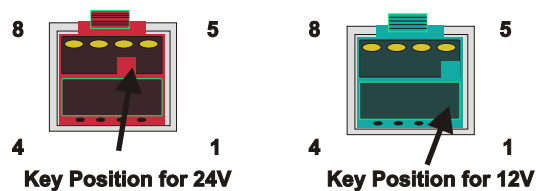

5.6 Riser Card Connectors

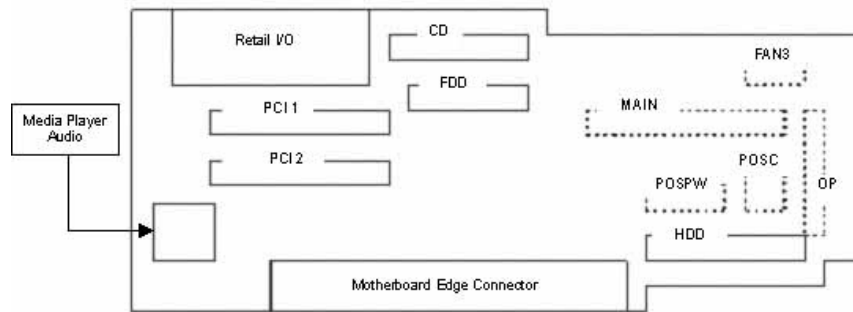

Note: Dashed lines are components on the opposite side. There are two riser cards:
 Revised riser card, 2 PCI slots, KD20033-B41X supports TeamUSB, TeamCOMBO and Retail I/O boards.
 Original riser card, 2 PCI slots, CA21259-B21X supports Retail I/O and TeamCOMBO only.

The revised riser card (KD20033-B41X) automatically detects the settings for TeamCOMBO and Retail I/O board or TeamUSB board.

There are two jumpers on the back side of the riser card for 5V Standby and LED Power. The jumper settings are shown below.

| | LED Power | 5V Standby |
|--------------------|-----------|------------|
| A or H Motherboard | 1-2 | 1-2 |
| M Motherboard | 2-3 | 2-3 |

5.7 CD-ROM/CD-RW/DVD (Media Player) Installation

The term media player in this manual refers to any of the options: CD-ROM, CD-RW or DVD. The following instructions show how to install a media player upgrade, where none was previously installed. If the media player is being replaced, due to failure, refer to the maintenance section of this manual.



Caution: To prevent electric shock, confirm that the AC cable is removed from the AC outlet anytime the covers are removed. Be sure to observe all ESD precautions and power off procedures.

1. Remove the front cover (see section 5.1.1).
2. Remove EMI shield. This picture shows the media player already in place.



EMI Shield

3. Disconnect power and signal cables from the Retail I/O, TeamCOMBO or TeamUSB board at the back of the unit.
4. Remove side cover (left) (see section 5.1.2).
5. Remove the top cover (see section 5.1.4)
6. Remove the screw from the perforated filler plate (not shown) that occupies the space intended for the media player.
7. Remove Retail I/O, TeamCOMBO or TeamUSB Board. (see section 7.13)

8. Insert the media player through the front opening with the ribbon cable and audio cable. See photo on opposite page. Ensure guides on left hand side of media player align above chassis guides.

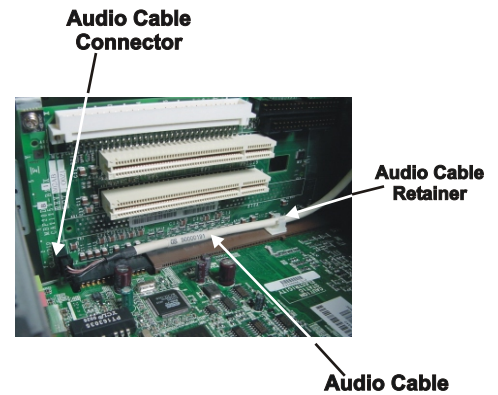

9. Route the audio cable under the floppy disk ribbon cable, which is attached to the riser card, and connect to the audio connector on the riser card. Use the audio cable retainer. Check that the cable will not interfere with the removal of the PC-board.

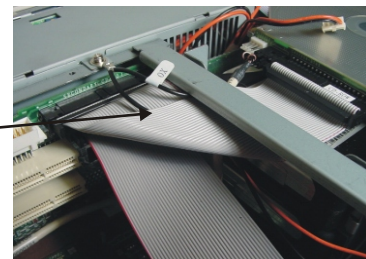

10. Bend the media player ribbon cable to form a 90° angle and install on the riser card connector.

11. Locate the media player power connector. It is one of the power supply unit's wiring harnesses. Cut the tie wrap and connect the Media Player power connector to the media player. It is polarized, so make sure it is installed correctly.

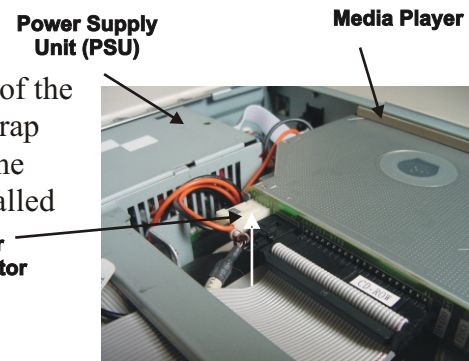

12. Push the media player completely into the controller ensuring that it is level and the mounting hole matches the mounting bracket. Secure with the mounting screw.

13. Re-install the Retail I/O, TeamCOMBO or TeamUSB board and covers.

14. Remove filler in front cover to allow access to the media player.

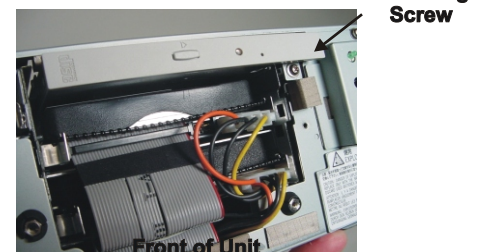

15. Once all covers have been reinstalled, verify the media player's disk tray will open properly by use of the manual tray release. Adjust front panel if disk tray sticks.

16. When installing media player, ensure that the upgrade label that comes with the media player upgrade kit is applied to the side of the control unit (see section 5.2.1)

5.8 PoS Peripheral Installation

Note: Peripheral software, such as OPOS, JAVAPOS, is available from www.ftxs.fujitsu.com/fujitsutemp.asp?navid=47.

5.8.1 Model 133UQ Keyboard Unit (programmable)

(PIN #'s 90000598, 90000985, 90000627, 90000628, 90000629 (shown))



Drivers and the keyboard programming utility for the 133UQ keyboard are available at www.preh.com PoS Data Systems Support, software, and drivers for all Preh Electronics products Programming Software/Driver/Tools then look for WinProgrammer 2.0; or link through Fujitsu's FTP site at <ftp://ftp.ftxs.fujitsu.com/pos>.
possustaining, Retail Keyboard 133UQ PrehDrivers shortcut. The firmware update utility is also in this same location on Fujitsu's FTP site. Look for 'Bootloader.'

The picture below shows two possible cable paths, one exiting the side of the back and the other exiting the center back (see arrow)

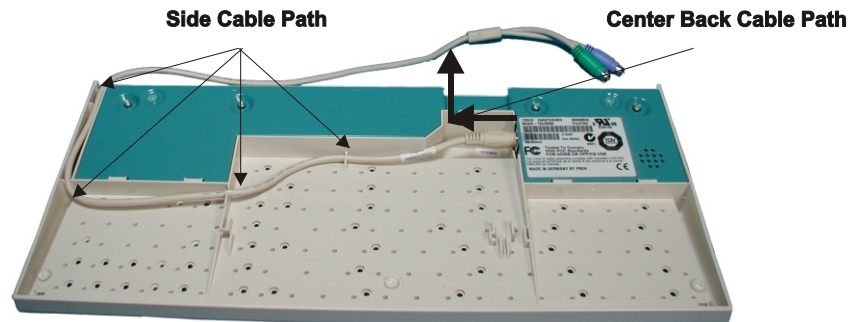

5.8.2 Model 92U Keyboard Unit (programmable)

The 92U supports both RS232 and USB interfaces through a single 8-pin connector. To configure for one or the other interface, order the appropriate cable. For USB, use 90000634 (0.6M) or 90000635 (3.8M). For RS232, use 50275/001 (0.6M), 50275/002 (3.0M) or 50275/003 (5.0M).

(PIN #s 90000630 keyboard, 90000631 MSR, 90000632 display,)



This keyboard is scheduled for release late Q2 of 2004. When it is released, drivers and the keyboard programming utility will be available through Fujitsu's FTP site at <ftp://ftp.ftxs.fujitsu.com/pos>, choose possustaining Retail Keyboard 92U. The firmware update utility for the 133UQ also works for the 92U. It is located in the keyboard section of the FTP site under 133UQ.

5.8.2.1 Model 92U Keyboard Switch Settings

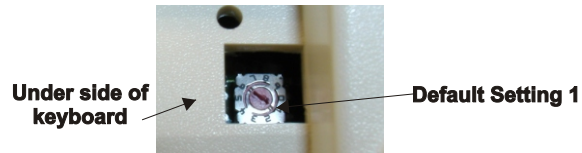

The keyboard assembly has a 10-position rotary address switch located next to the interface cable connection. See photo above.

| Switch Number | Function |
|---------------|--|
| 0 | Offline Diagnostics |
| 1 | MSR 1, 2 & 3 |
| 2 | Not used |
| 3 | Not used |
| 4 | Not used |
| 5 | MSR 1 & 2 emulation |
| 6 | MSR 2 & 3 emulation |
| 7 | Not used |
| 8 | Not used |
| 9 | Returns keyboard layout to the factory setting during power up |

5.8.3 Model 133PQ Keyboard Unit (not programmable)

(PIN #'s **PB600335, PB600315, 90000627-29**)



5.8.3.1 Model 133PQ Keyboard Switch Settings

The 133PQ switches are located in the MSR compartment which is entered from the bottom of the keyboard. These settings set the MSR to read track 1 & 2 or track 2 & 3. The third setting is used in the Asian market only.

| Switch Position | Reads Track(s) |
|-----------------|---------------------|
| Left | Asian Setting |
| Center | Track 2/3 |
| Right | Track 1/2 (default) |

5.8.3.2 Model 133PQ Keyboard MSR Installation

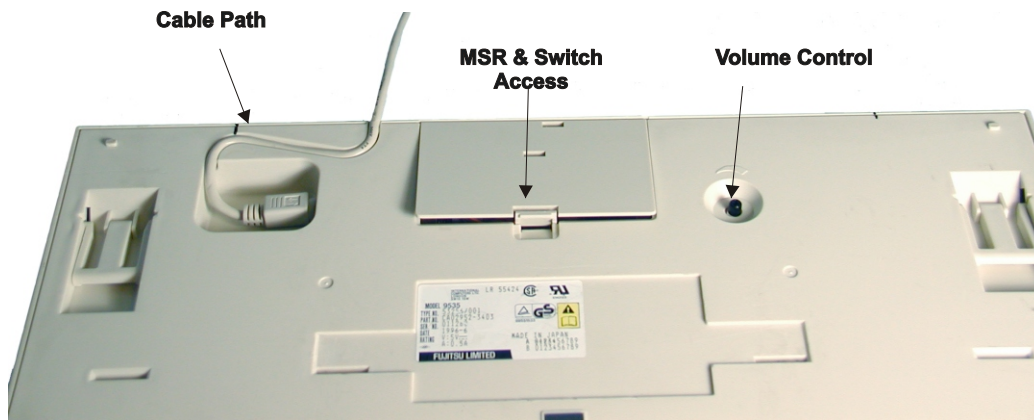

1. To install and set the switches for the MSR, first open access cover on bottom of keyboard.
2. Place access cover on bottom of panel.

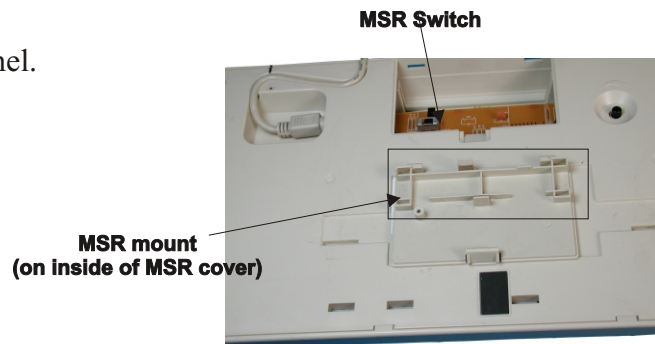

3. Check switch settings. Switch in this photo is in the default position, read track 1/2.

4. Fit the MSR into the frame inside the MSR cover. The circuit board should face the latch. This is the only way that the MSR can be installed. Be sure the connecting wires come out from under the MSR on the circuit board side.

MSR mounted
on cover

Latch

MSR connector

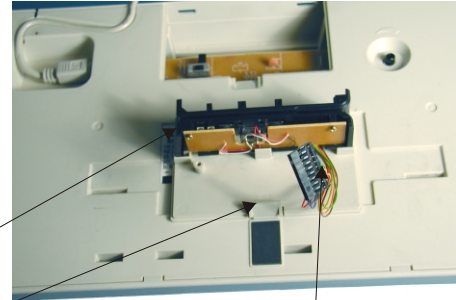

5. Slip the end of the wire onto the pin connector in the MSR space, smooth side up. The wires can only be connected one way.

Wire connector



6. Flip cover over and ease the MSR into the slot, aligning the slot in the MSR beneath the slot in the keyboard.

5.8.4 Model 104P Keyboard Unit (Compact Keyboard)

(PIN #'s 90000175)



5.8.4.1 Model 104P Keyboard Default Layout

The following is the default keyboard layout which may not match the customer's layout. The keyboard is programmable. The keyboard mapping utility is on the Fujitsu FTP site at <ftp://ftp.ftxs.fujitsu.com/pos/>.

| | | | | | | | | | | | | |
|-----------|------|-----|-------|-----|------|-----|----------------|----------------|-----------|----------------|----------------|----------------|
| ESC | F1 | F2 | F3 | F4 | F5 | F6 | Ins | Home | Page up | - | + | BKSP |
| TAB | F7 | F8 | F9 | F10 | F11 | F12 | Del | End | Page down | 7 | 8 | 9 |
| Caps Lock | ~ | \ | { } | ? / | : | " | OPOS POS KEY A | OPOS POS KEY B | | 4 | 5 | 6 |
| ! | @ | # | \$ | % | ^ | & | * | (|) | 1 | 2 | 3 |
| 1 | 2 | 3 | 4 | 5 | 6 | 7 | 8 | 9 | 0 | OPOS POS KEY C | 0 | . |
| Q | W | E | R | T | Y | U | I | O | P | | | |
| A | S | D | F | G | H | J | K | L | Enter | OPOS POS KEY E | OPOS POS KEY F | |
| Z | X | C | V | B | N | M | < | > | ↑ | OPOS POS KEY G | OPOS POS KEY H | OPOS POS KEY I |
| Shift | Ctrl | Alt | SPACE | Alt | Ctrl | ← | ↓ | → | | | | POS Enter |

5.8.4.2 Model 104P Keyboard Switch Settings (Compact Keyboard)

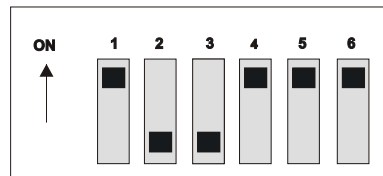

The Model 104P keyboard has DIP switches as follows. Default settings are in bold::

| Switch | | | | | | | |
|--------|-----------|------------|------------|---|---|---|--|
| | 1 | 2 | 3 | 4 | 5 | 6 | Meaning |
| 1,2 | ON | ON | | | | | ISO 1/2 (Not Used) |
| | OFF | ON | | | | | ISO 2/3 (Not Used) |
| | ON | OFF | | | | | ISO 1/2/3 (Default) Supports MSR options |
| | OFF | OFF | | | | | JIS 1/2 (Not Used) |
| 3 | | | ON | | | | F key roll-over |
| | | | OFF | | | | 2 key lock-out (Default) |

| Switch | | | | | | | Meaning |
|--------|---|---|---|-----|-----|-----|---|
| | 1 | 2 | 3 | 4 | 5 | 6 | |
| 4 | | | | OFF | | | POS command invalid MSR default Enabled |
| | | | | ON | | | POS command valid (Default) MSR default Disabled |
| 5,6 | | | | | ON | ON | KEYMAP A (Default) |
| | | | | | OFF | ON | KEYMAP B (Not Used) |
| | | | | | ON | OFF | KEYMAP C (Not Used) |
| | | | | | OFF | OFF | KEYMAP D (NotUsed) |

5.8.4.3 Model 104 Keyboard Volume Adjustment

The volume control of the buzzer is on the bottom of the keyboard unit. Turning the control clockwise increases the volume.

5.8.4.4 Model 104P Keyboard, Mounting the MSR

1. Remove MSR slot filler from the MSR keyboard slot and the cable from the bottom of the keyboard.

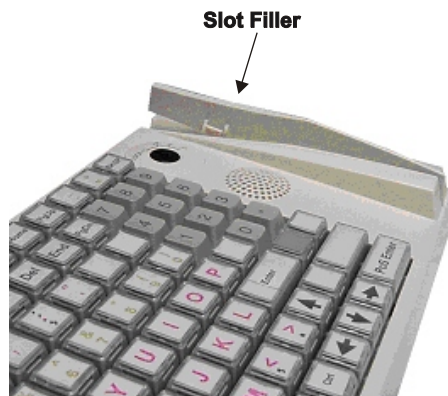

2. Remove the bottom cover of the keyboard unit by depressing the three tabs and pulling bottom cover upward.

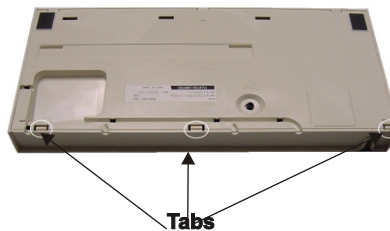

3. Connect the MSR cable to the MSR unit with the conductors on the cable exposed away from the MSR unit (up).

Connect the MSR cable to the MSR unit with the conductors on the cable exposed away from the MSR unit (up).

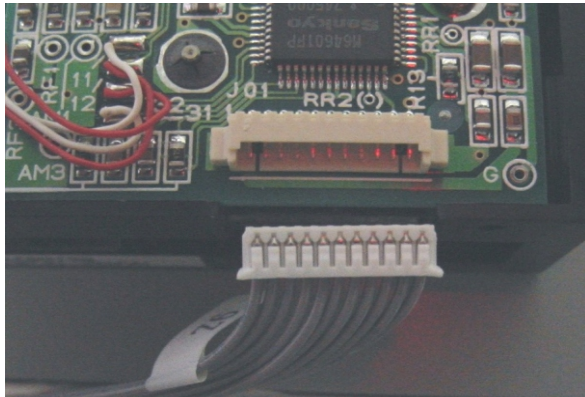

**Exposed connectors up.
Bottom is solid plastic.**

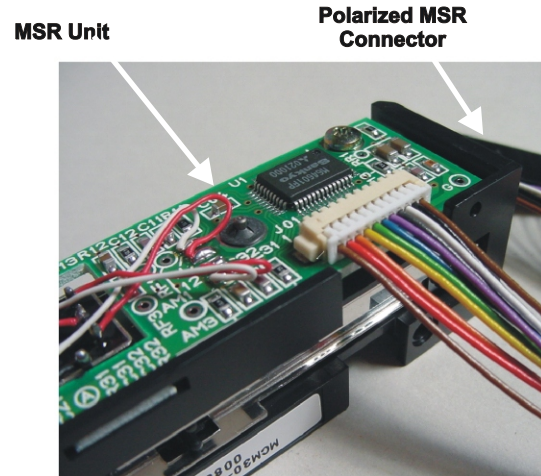

Set the larger opening of the MSR unit to the corresponding larger opening on the keyboard unit.

5. Connect the cable to the printed circuit board of the keyboard with exposed conductors faced down.
6. Replace the bottom cover of the unit.
7. Plug in the keyboard cable.



5.9 Model D15 LCD Stands

The 15" Liquid Crystal Display (LCD) used with the TeamPoS 2000 is a TFT technology and has both digital and analog interfaces and speakers. Options include touch, keypad and MSR. Touch options are factory installed and cannot be field installed. Built-in speakers are standard.

Model D15 Stands: two stands are available:

1. Stacked stand, for stacking the D15 with or without SmartPoSKeyPad options on a control unit.
2. Dispersed stand, for dispersing the LCD with or without the SmartPoSKeyPad, SmartPoSMSR options on a checkstand or counter.
3. A third mount is an in-counter mount which consists of a cable, a connector that attaches to the LCD and an interface for connecting external cables (in development).

The following table summarizes the D15 LCD stands and options:

| | D15 non-touch | D15 touch | D15 w/MSR, w/keypad, or w/keypad&MSR |
|-----------|---------------|-----------|--------------------------------------|
| Audio | Yes | Yes | Yes |
| Touch | No | Yes | Yes |
| Stacked | Yes | Yes | Yes |
| Dispersed | Yes | Yes | Yes |
| Kiosk | NA | NA | NA |

5.9.1 D15 LCD Cable Requirements

The following graphics show D15 LCD cable requirements for various configurations of digital and analog LCDs. Refer to the cable summary at the end of these graphics for cable part numbers.

5.9.2 D15 LCD Audio Cable Connections

Audio connections to the LCD are the same for digital as for analog. The audio cable plugs

into the audio port on the motherboard (A or M) and to the audio port on the bottom of the D15 stand. In dual screen configurations, only one LCD can have the sound enabled.

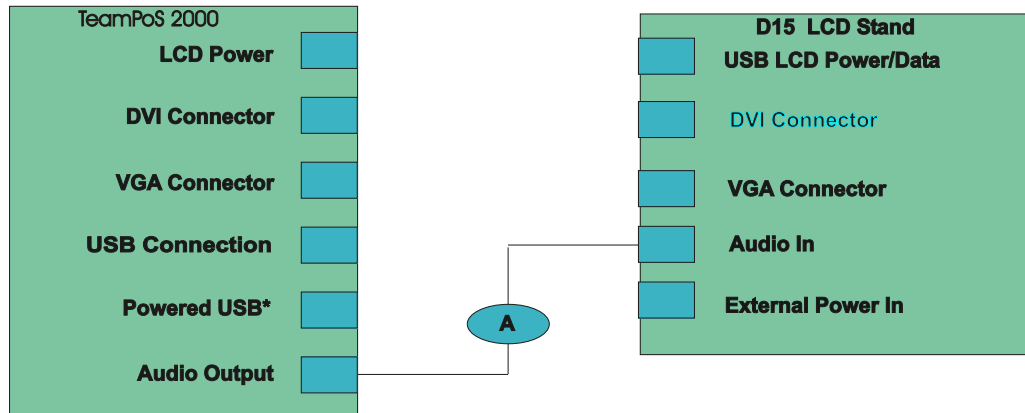

**TeamPoS 2000 & D15 Audio Connection for
TeamUSB, TeamCOMBO & Retail I/O Boards**

5.9.3 D15 LCD Video Data Cable Connections

Video connection is made to either the VGA or DVI port on the motherboard and the matching port on the LCD Stand. The DVI connection can be used only with Pentium M or Celeron M motherboards. Only one digital and one analog LCD can be connected to the motherboard at any one time. When two LCDs are supported by one TP2K, one of the monitors must use the DVI connector and the other must use the VGA connector.

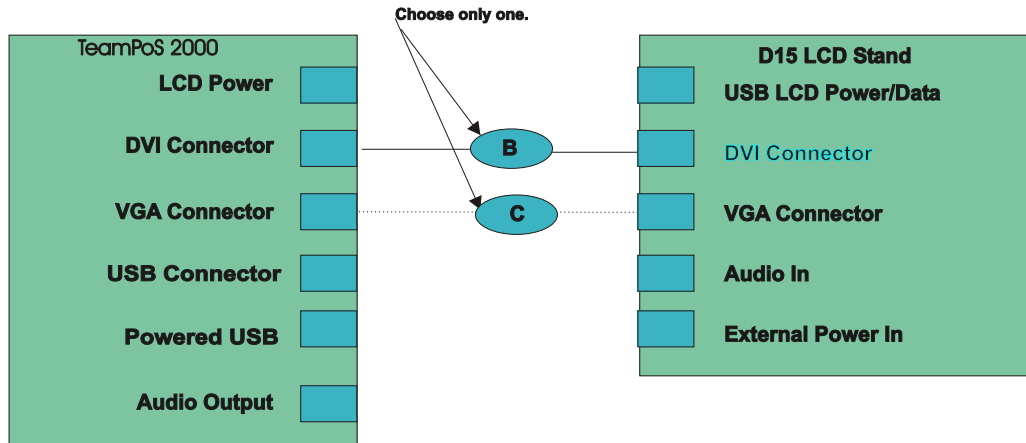

**TeamPoS 2000 & D15 Video Connections for
TeamUSB, TeamCOMBO & Retail I/O Boards**

5.9.4 D15 LCD Dual Monitor Video Cable Connections

When dual monitors are used, one monitor uses the DVI connector and the other uses the VGA connector to the motherboard. Only Celeron M or Pentium M have DVI support. configuration. In this example, the DVI connector is connected to the first stand and the VGA cable is connected to the second stand. The DVI cable could just as easily be connected to the second monitor and the VGA cable connected to the first.

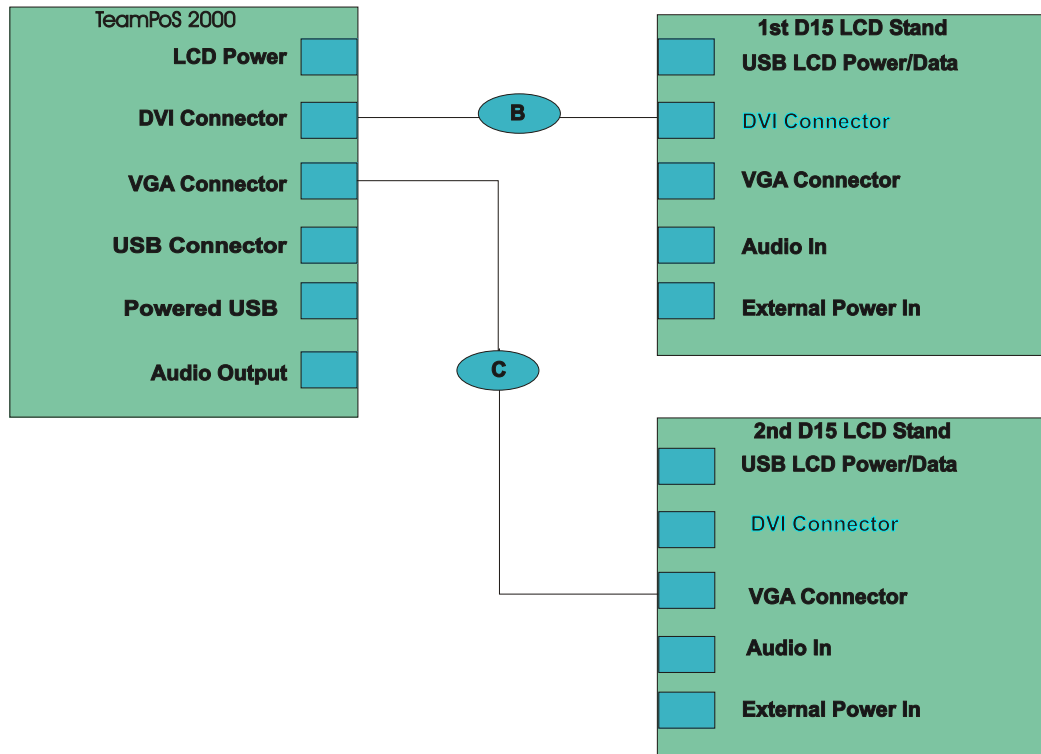

**TeamPoS 2000 & D15 Dual Screen Connections for
TeamCOMBO & TeamUSB* Boards**

* TeamUSB only supported with new riser cad, PIN #KD20033-B41X.

5.9.5 D15 LCD Power and Data (Touch, MSR and Keypad) Cable Connections

Unlike D15 LCD video and audio cable connections, it *does* make a difference which I/O board is configured when connecting power and data. A typical configuration is for non-touch.

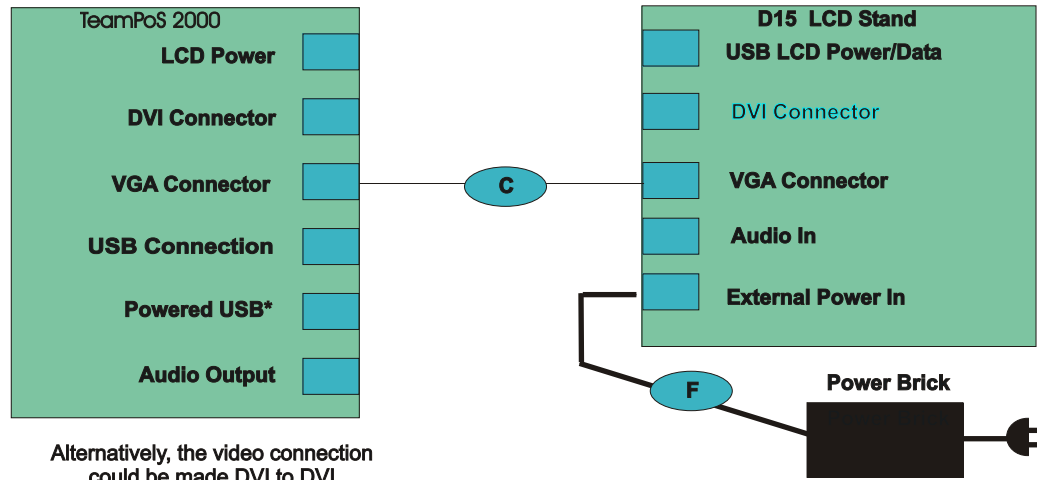

TeamPoS 2000 Non-touch Connections

The powered USB cable makes it possible to connect power and data with the same cable.

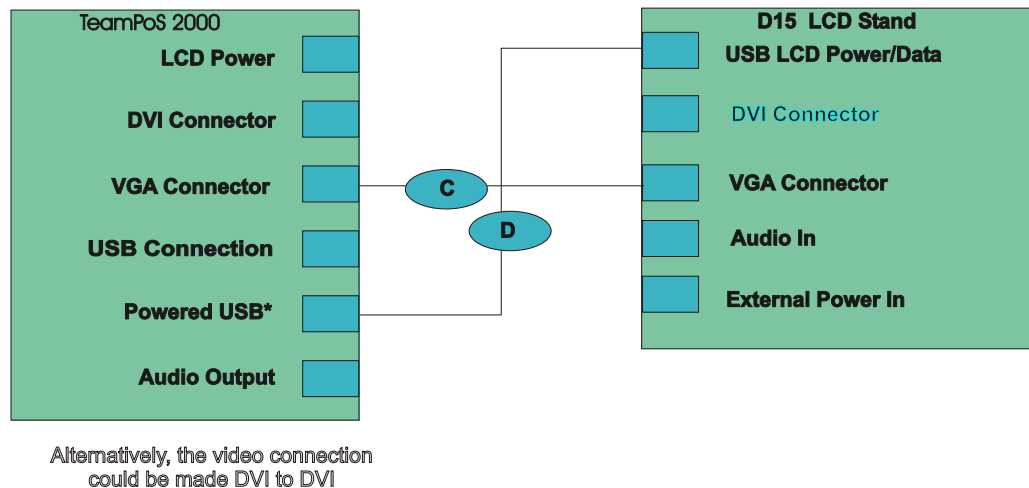

TeamPoS 2000 w/TeamUSB I/O Board w/Touch and/or MSR and/or Keypad Alternate configuration for non-touch

The Retail I/O (90000161) and TeamCOMBO (90000273) boards do not have sufficient power to drive the D15 LCD and in this configuration need to use a power brick. The data connection (touch, MSR and/or keypad) is made using an A-to-A USB connector (male-to-male). One end is plugged into any open-powered USB port on the I/O board or to one of the motherboard standard USB ports and the other end is plugged into any open USB port on the I/O board or one of the standard USB ports on the motherboard.

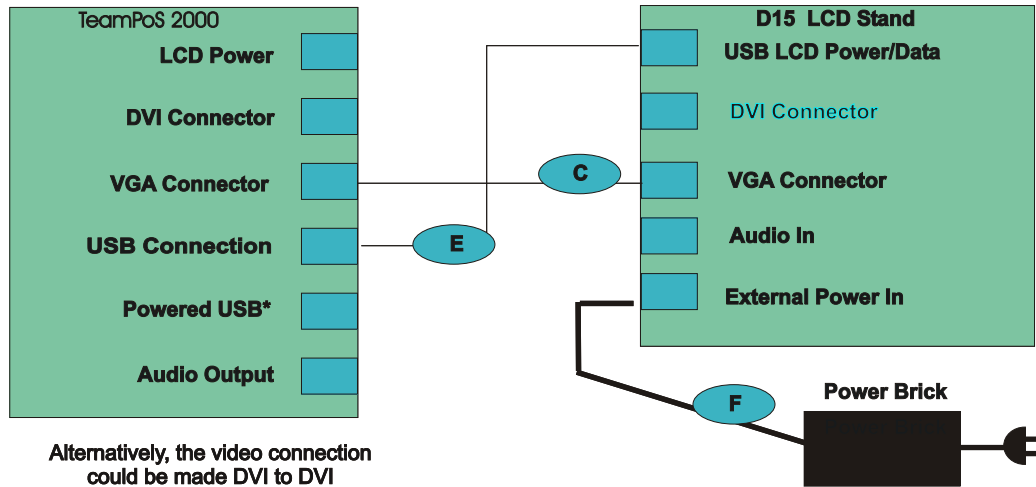

TeamPoS 2000 & Retail I/O Board Touch and/or MSR and/or Keypad

When using dual screens and the TeamUSB (90000803) or TeamCOMBO II (9001036) I/O boards, only one D15 LCD may be powered by the TeamPoS 2000 using the powered USB connector. The second screen is powered using a power brick. The data for the screen which uses the power brick requires a standard A to A USB connector. Keep in mind that each LCD must use a different video connector, one VGA and one DVI as shown below. If a Retail I/O or TeamCOMBO board are used, both LCDs must be powered from a power brick.

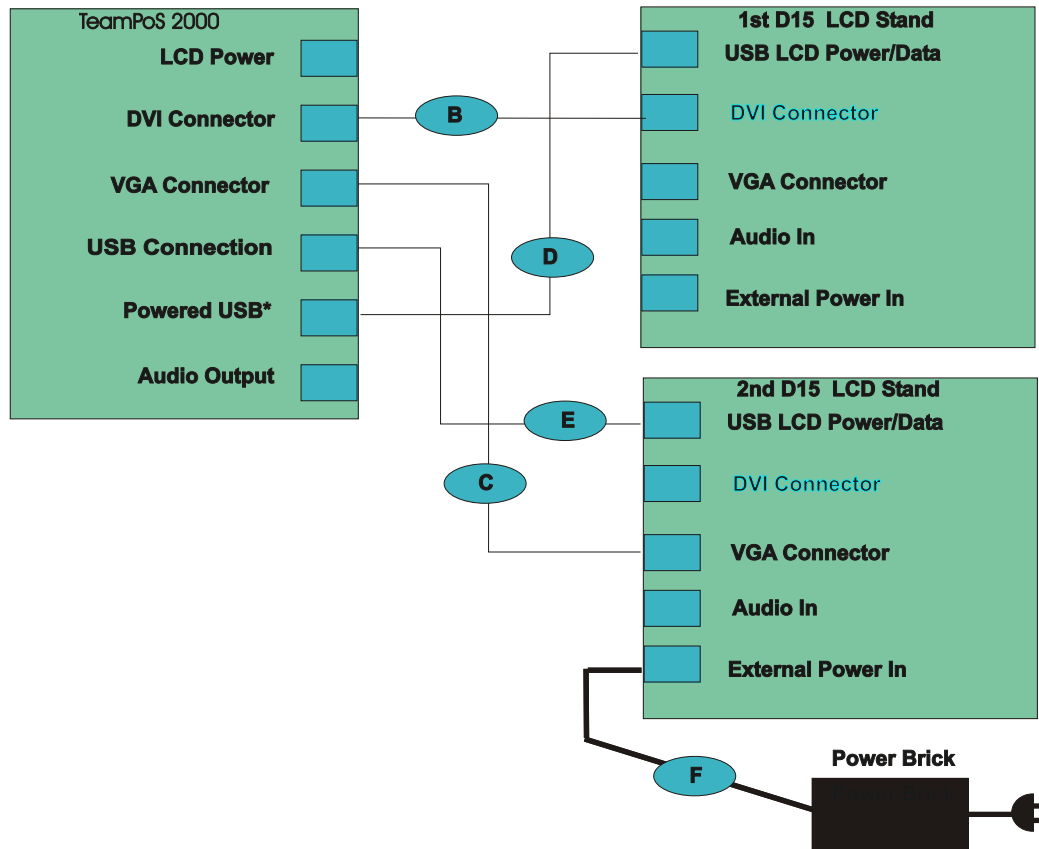

**TeamPoS 2000 & TeamCOMBO or TeamUSB Board
or Retail I/O Board (with M Motherboard only)
Dual Screen Configuration w/Touch
and/or SmartPoSMSR and/or SmartPoSKeyPad**

D15 cables connect to the ports on the bottom of the dispersed or stacked stands. These cables are shown below.

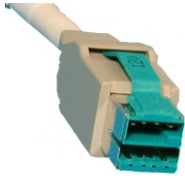

**+12V Powered
USB Cable**



DVI Cable



VGA Cable



Audio Cable







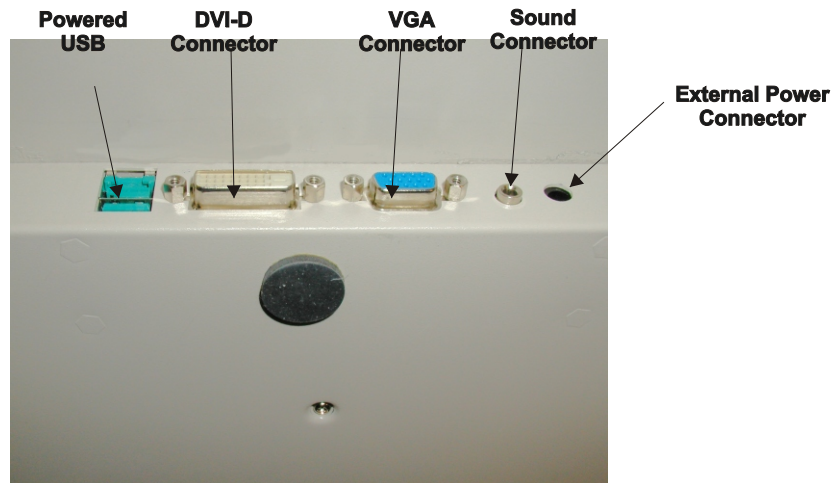

LCD Power Brick

The stacked and dispersed stands contain circuit boards and are wired so that data or power from the TeamPoS 2000 travels within the stand through a specially designed cable. Although there are multiple connectors on the bottom of the stands, there is only one connection to the D15 LCD. An in-counter mount will be included in a future release.



5.9.6 D15 Cable Summary

| | |
|--|--|
|  |  |
| <p>Audio Cables, 1 required for each speaker option:</p> <p>CA05951-3131 CBL, D12 Audio/Stacked/0.65M CA05951-3132 CBL, D12 Audio/Dispersed/2.0M CA05951-3133 CBL, D12 Audio/Dispersed/5.0M</p> | <p>LCD Powered USB Cables, 1 required for each LCD in TEAMUSB or TeamCOMBO configuration:</p> <p>90000835 CBL D15 PWR/USB/STACKED/0.65M 90000836 CBL D15 PWR/USB/DISPERSED/2.0M 90000837 CBL D15 PWR/USB/DISPERSED/3.8M</p> |
|  |  |
| <p>LCD DVI cable, 1 required for each LCD operating in digital mode:</p> <p>90000826 CBL D15 Stacked/DVI/.65M 90000827 CBL D15 DVI Dispersed/2.0M 90000828 CBL D15 DVI Dispersed/3.8M</p> | <p>USB Standard Connector, A to A, 1 required for each LCD using touch, keypad or msr and not using Powered USB cable above:</p> <p>90000992 - CBL TP2K USB/AtoA/0.65M (stacked) 90000993 - CBL TP2K USB/AtoA/2.0M (dispersed) 90000994 - CBL TP2K USB/AtoA/3.8M (dispersed)</p> |
|  |  |
| <p>LCD VGA cable, 1 required for each LCD operating in analog mode:**</p> <p>90001046 D15 Analog Data /0.65M 90001047 D15 Analog Data/2.0M 90001048 D15 Analog Data/5.0M</p> | <p>Powered brick for LCD power, 1 required for each LCD configured with a Retail I/O or TeamCOMBO board</p> <p>90000829 OPN D15 LCD Power Supply</p> |
| <p>(*) Audio cables for the D15 LCD are the same audio cables used for the D12 audio connection. (**) VGA cables for the D15 LCD are the same cables used for the analog connection for the A12 LCD.</p> | |
| <p>Notes:</p> <ul style="list-style-type: none"> • The powered USB and standard USB cables provide data for touch, MSR and keypad • Power bricks do not come with the mains cable to connect the power brick to AC power outlet. These must be ordered separately. | |

5.9.7 Model D15 LCD Installation

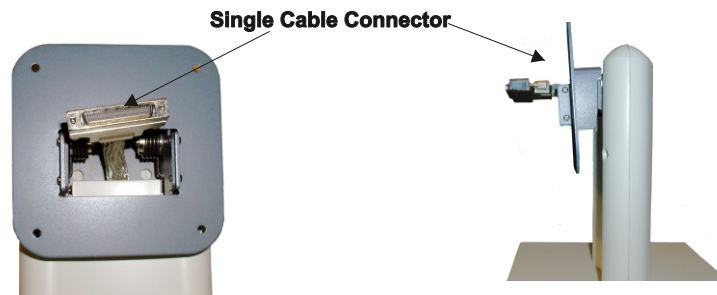

5.9.7.1 Dispersed Stand Installation

Leave the protective sheet attached to the LCD until installation is complete. To install the D15 LCD on either the dispersed stand or the stacked stand (in development):

1. Place the LCD face down on a clean surface. Make sure the surface is free of anything that might damage the screen.
2. Tip the stand on its front side until the cable connector in the stand can be pushed onto the connector on the D15.

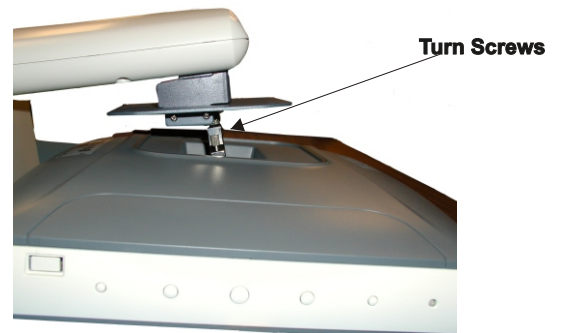

3. Pry off the back panel of the stand to expose access holes. Use a screw driver, inserted through the connector access holes, to assist and to gently tighten the connector turn screws. Tighten the turn screws until the cable connection is secure. Do not overtighten so that it will be possible to remove the LCD if needed.

Access Holes



4. Mount the stand onto the D15 using the 4 screws taped to the bottom of the stand. There are access holes in the stand to facilitate fastening the bottom two mounting screws. Reattach the back panel.

Screw holes

Back Panel

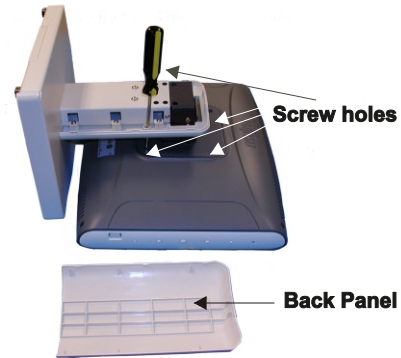

5.9.7.2 Stacked Stand Installation

1. Place the LCD face down on a clean surface. Make sure the surface is free of anything that might damage the screen.



2. Unscrew the screw at the back of the protective cover to access connector on D15.



3. Tip the stand on its front side until the cable connector can be pushed onto the connector in the back of the LCD. Use a screwdriver to gently tighten the connector screws until the LCD is secure. Do not overtighten so that it will be possible to remove the LCD if needed. Replace protective cover.



4. Install the D15 stacking plate onto the top of the TeamPoS 2000 using thirteen M3 x 5 Phillips Flat Head screws.

5. Install the D15 base mounting bracket using four M3 x 5 Phillips Flat Head screws with the bracket hooks forward. The brackets for the keyboard and printer need to be installed on the stacking plate as well. (See D12 and A12 Stacking Bracket Locations Section 5.1.5.)

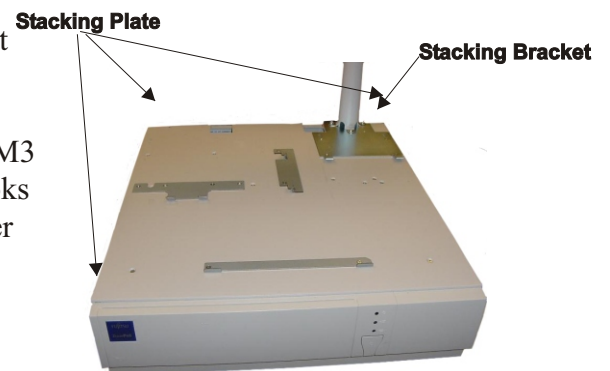

6. Connect all the required cables to support the D15 Display, route them through the opening to one side of the space for the pole mount, remembering to also thread the keyboard cable under the D15.
7. Slide the D15 onto the mounting bracket.

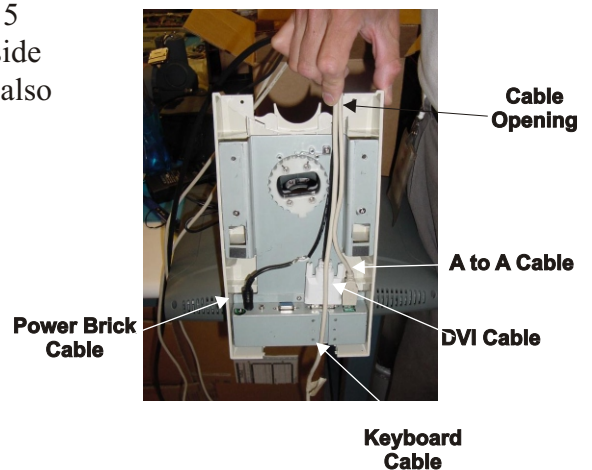

5.9.7.3 SmartPoSMSR Installation

An MSR can be installed on any of the model D15 LCDs.

1. Place the D15 face down on a clean surface, making sure there is nothing that will damage the screen. The bottom edge of the unit should be nearest to you.



2. Remove the left-side gray access cover and the contrasting end cap.



3. Align the shim that came with the D15 so that it matches the contour of the side of the D15.



4. Thread the connecting wire of the MSR through the shim up to the black insulation.
5. Connect the small white connector to the side of the LCD. The connector has a key so it will only fit one way.



6. Slide the metal brace through the shim and into the side of the back panel. There are three grooves that act as guides. It only fits one way.

Push the shim and MSR brace into the LCD until they fit snugly against the D15. The 3 screw holes in the brace will line up with the three screw holes on the back of the D15. Use the 3 screws provided with the MSR kit to secure the MSR.

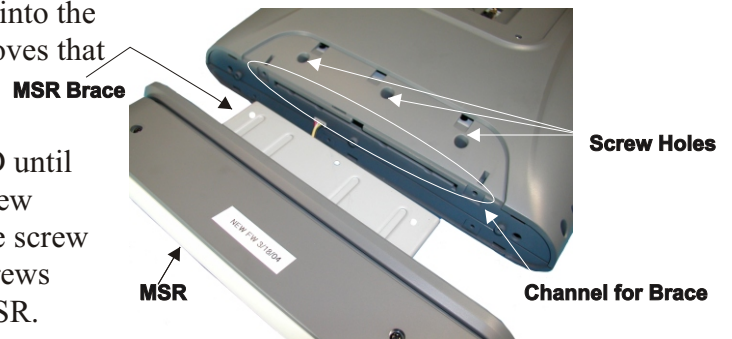

7. Reattach the access panel by inserting the tabs at the left first and then snapping the right tabs into place.

After installation power up and test MSR with test card.



5.9.7.4 SmartPoSKeyPad Installation

A 5 x 8 keypad can be installed on any of the D15 models:

1. Place the D15 face down on a clean surface, making sure there is nothing that will damage the screen. The bottom edge of the unit should be nearest to you.

Remove the left-side gray access cover and the contrasting end cap. (See MSR installation)

- Turn the D15 faceup on the counter and using a flat head screw driver, gently pry off the right side frame of the D15. Insert the the small white connector into the port on the D15.

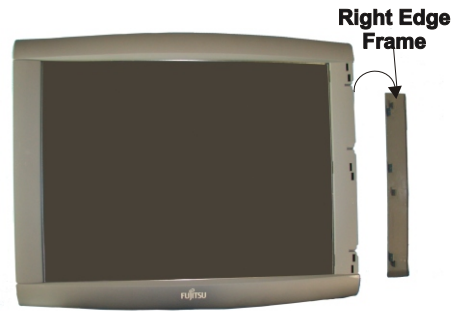

- Line up the metal brace and insert the edge in the grooved channel. Orient the D15 so that the end opposite the keypad is against your body. Lean to one side to view the slot. Slip just the edge of the metal keypad brace into the slot. Using a flat head screw driver pry up one end of the grooved panel and ease it over the top edge of the D15. Maintaining a steady pressure, slide the screwdriver along the edge until the entire cosmetic front panel slips over the front edge of the panel and push the keypad into place. The grooved, cosmetic panel covers the edge where the frame was removed.

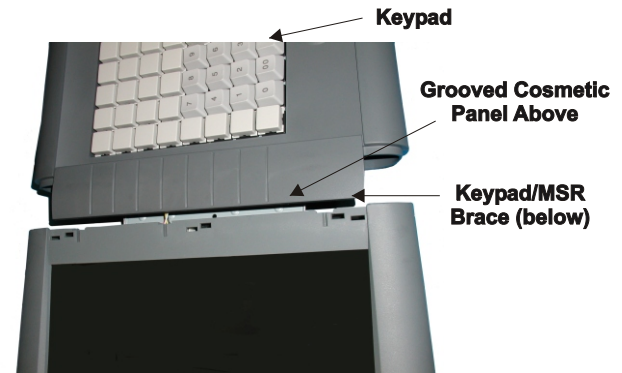

- Turn the D15 over to the back side and secure the keypad with 3 screws provided with the keypad. Snap on the back panel.

5.9.7.5 SmartPoSKeyPad & MSR Installation

The keypad and MSR come together in the kit. Follow the directions for the keypad installation.

5.9.7.6 VF50U Stacked Customer Display Installation

- As with the D15 installation, the VF50U display begins with the installation of the stacking plate onto the top of the TP2K using thirteen M3 x 5 Phillips Flat Head screws.

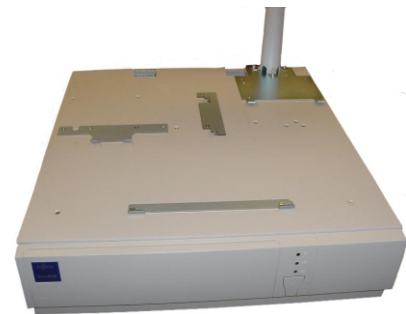

2. Install the D15 base mounting bracket using 4 M3x5 Phillips Flat Head screws.
3. Thread the VF50 cable through the display pole and install the short display pole using three M5 screws. **Do not tighten screws completely.**

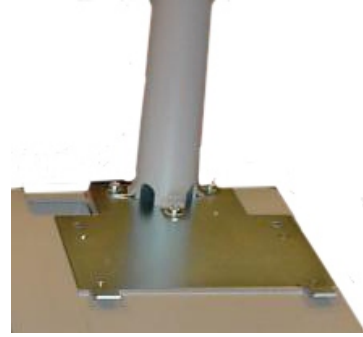

4. Route the PoS end of the display cable as shown.

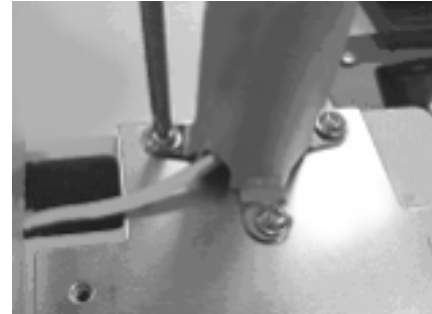

5. Attach the D15 display assembly (temporarily) to help center and position the short display pole.



5. Tighten the two rear M5 screws. Remove the D15 display assembly and tighten the third M5 screw.



6. Connect all of the required cables to support the D15 display and route the keyboard cable under the stand as shown.

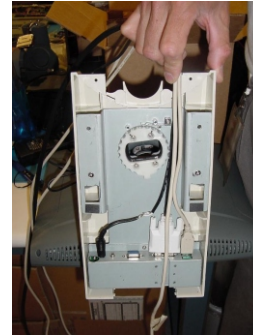

7. Install the D15 display assembly onto the TP2K and route the cables into the rear of the TP2K as shown.

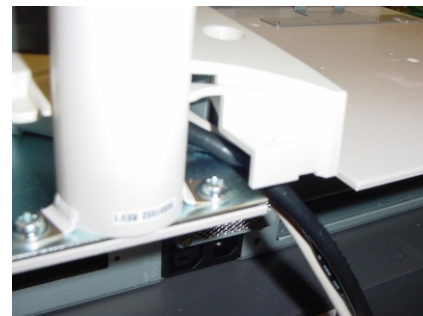

8. Install the two plastic topped screws to fasten the rear of the display base.



9. Attach the rear cover.



5.10 Models D12 and A12 LCD Installation

The 12.1" Liquid Crystal Display (LCD) used with the TeamPoS 2000 is a TFT and has two types of interfaces, digital and analog. Options include touch, speakers, keypad with MSR and MSR only. Touch options are factory installed and cannot be field installed.

Three stands are available:

1. Stacked, for stacking the LCD configurations without TeamKey or MSR options on a control unit;
2. Dispersed (90000552), for dispersing the LCD without TeamKey or MSR options in a checkstand or counter; and
3. Kiosk stand (90000542), for dispersing an LCD with the TeamKey or MSR option.

5.10.1 Model D12 and A12 LCD Stand Option Summary

The following table summarizes the 12.1" LCD stand and options:

| | D12 Only | D12 w/ Keypad | D12 w/MSR | A12 Only | A12 w/ Keypad | A12 w/MSR |
|--------------------|----------|------------------|--------------|----------|------------------|--------------|
| Speakers | Yes | Yes | Yes | No | No | No |
| Touch | Yes | Yes | Yes | Yes | Yes | Yes |
| Stacked Stand | Yes | No | No | Yes | No | No |
| Dispersed Stand | Yes | No | No | Yes | No | No |
| Kiosk Stand | Yes | Yes | Yes | Yes | Yes | Yes |

The following sections describe cabling requirements and installation of the LCD and options.

5.10.2 12.1" LCD Cable Requirements

The following graphics show LCD cable requirements for various configurations of digital and analog LCD*. Refer to the cable summary at the end of these graphics for cable part numbers.

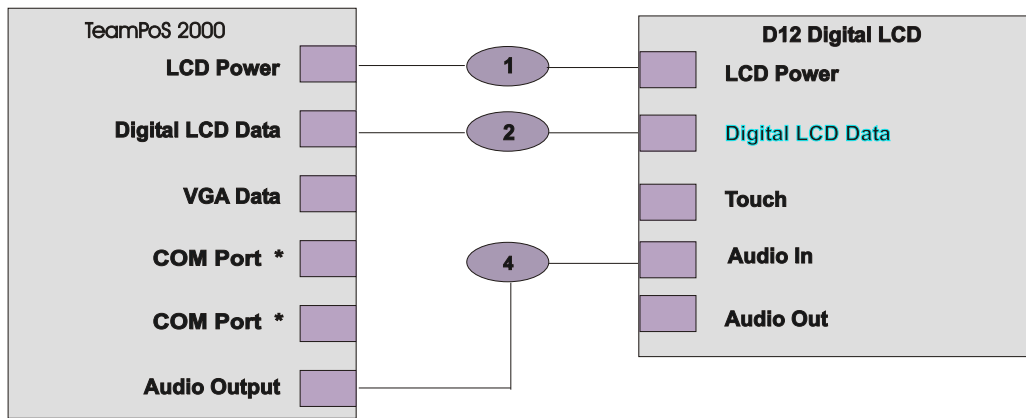

TeamPoS 2000 with Single Digital LCD

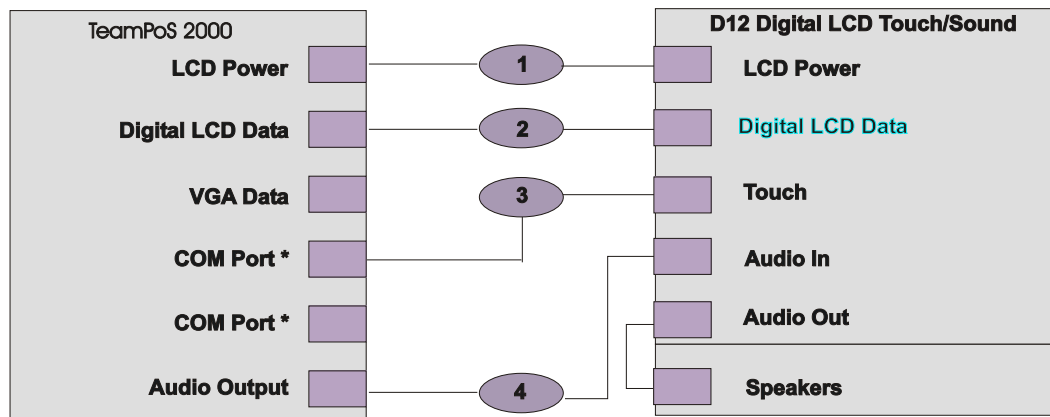

TeamPoS 2000 with Digital LCD, Touch & Speaker Options

* The application software will determine where the touch panels connect to the TeamPoS 2000. The touch cables can be connected to one of the PC board's COM ports or any male 5VDC connector on the Retail I/O Board (Ports 1, 2 or 5) or TeamCOMBO Board (Port 1 or 2)

LCD Cable Requirements (continued)

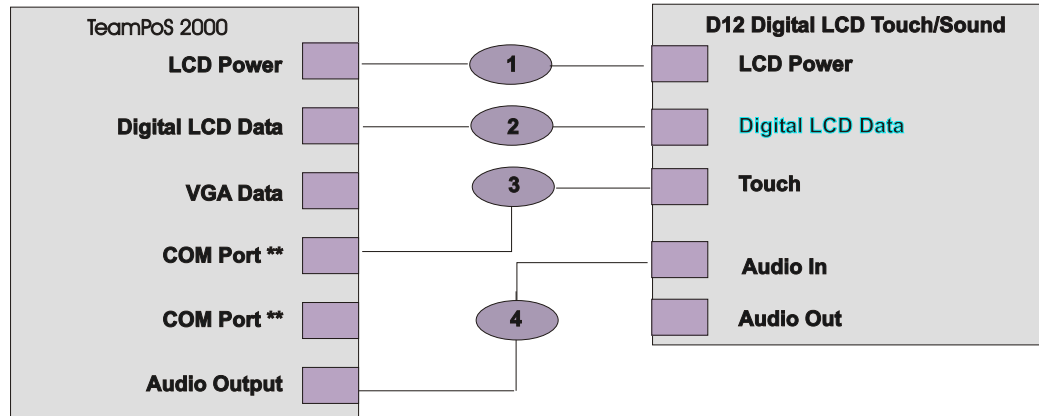

TeamPoS 2000 with Digital LCD and Touch Option**

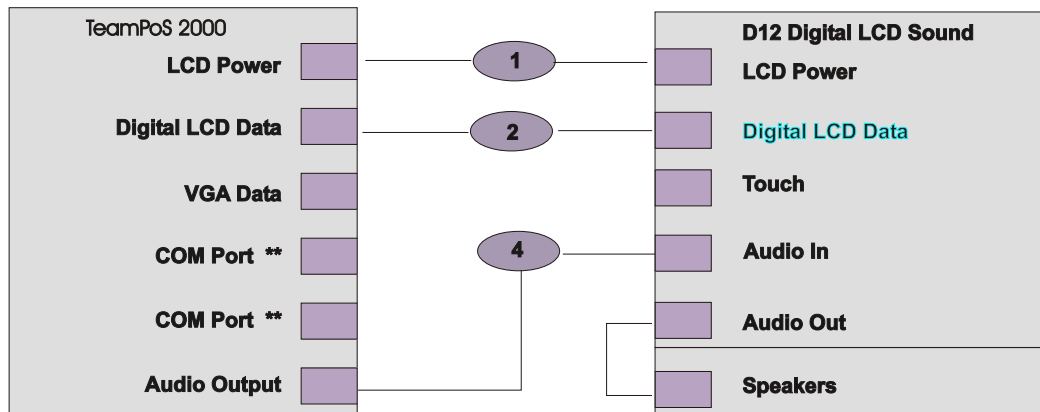

TeamPoS 2000 with Digital LCD and Speaker Option

** The application software will determine where the touch panels connect to the TeamPoS 2000. The touch cables can be connected to one of the PC board's COM ports or any male 5VDC connector on the Retail I/O Board (Ports 1, 2 or 5) or TeamCOMBO Board (Port 1 or 2)

LCD Cable Requirements (continued)

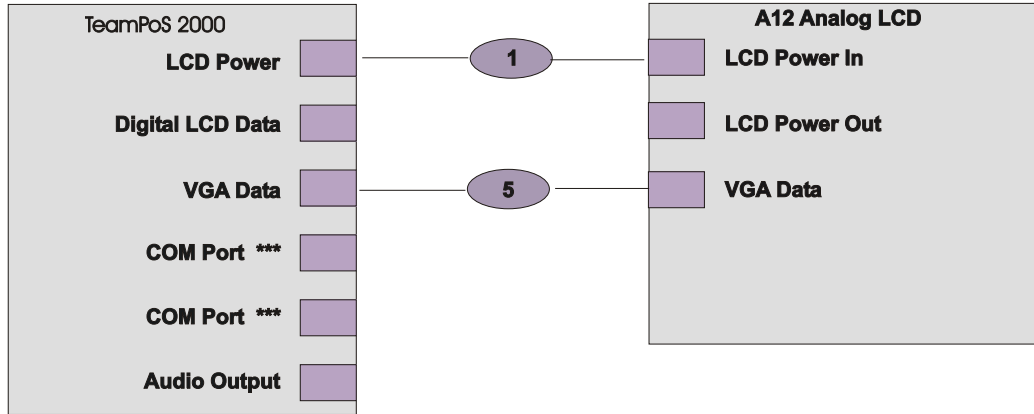

TeamPoS 2000 with Analog LCD

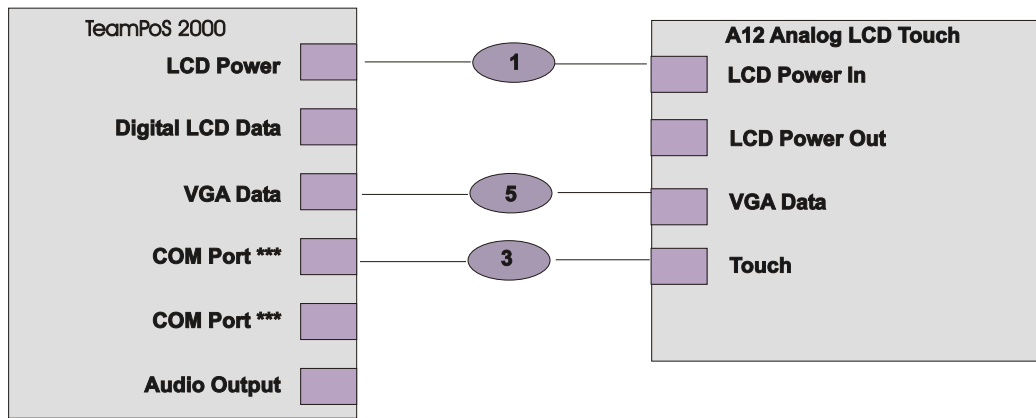

TeamPoS 2000with Analog LCD and Touch Option ***

*** The application software will determine where the touch panels connect to the TeamPoS 2000. The touch cables can be connected to ne of the PC board's COM ports or any male 5VDC connector on the Retail I/O Board (Ports 1, 2 or 5) orTeamCOMBO Board (Port 1 or 2)

LCD Requirements (continued)

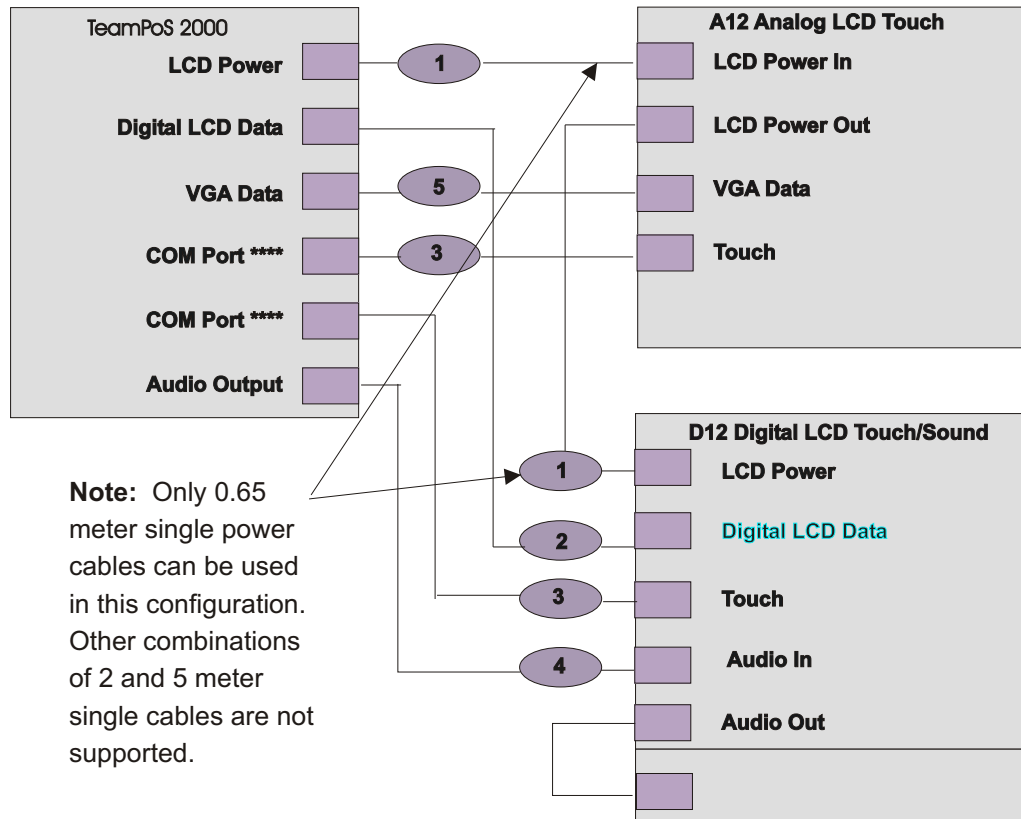

Note: Only 0.65 meter single power cables can be used in this configuration. Other combinations of 2 and 5 meter single cables are not supported.

Stacked TeamPoS 2000 with Digital LCD and Speaker Options and Analog LCD and Touch Option only ****

**** The application software will determine where the touch panels connect to the TeamPoS 2000. The touch cables can be connected to one of the PC board's COM ports or any male 5VDC connector on the Retail I/O Board (Ports 1, 2 or 5) or TeamCOMBO Board (Port 1 or 2)

LCD Requirements (continued)

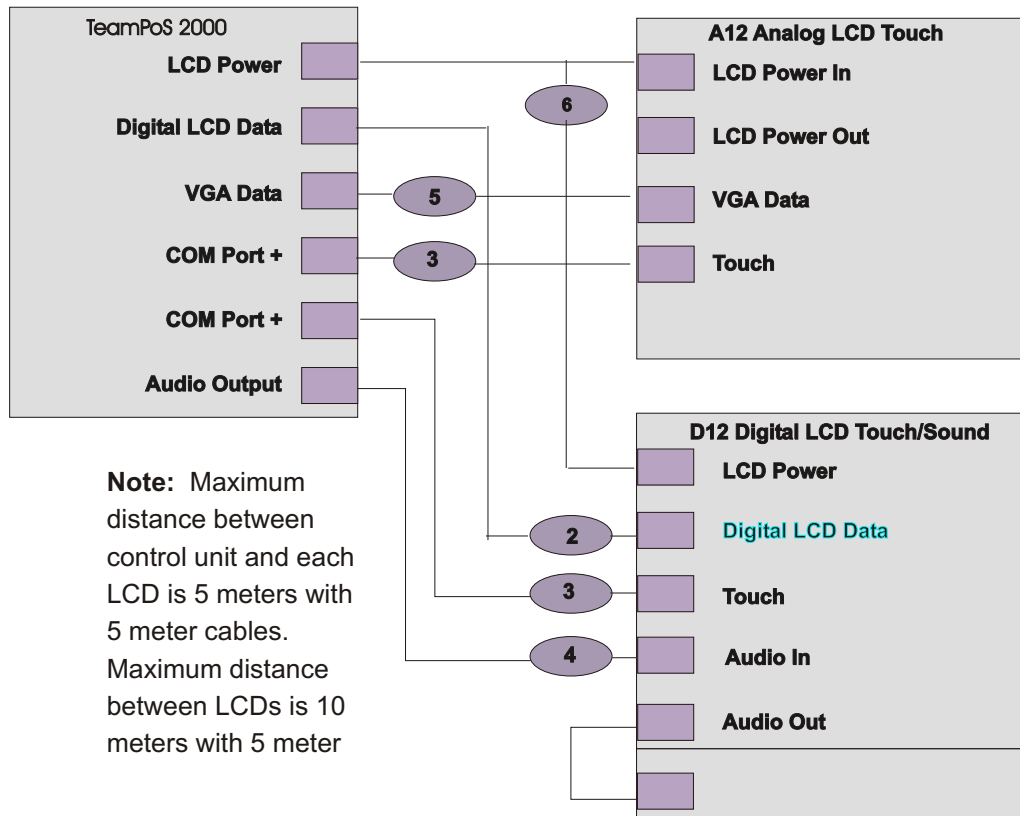

Dispersed TeamPoS 2000 with Digital LCD with Touch and Speaker Options and Analog LCD with Touch Option only⁺







LCD Cables (identical connectors at both ends of cable)



⁺ The application software will determine where the touch panels connect to the TeamPoS 2000. The touch cables can be connected to one of the PC board's COM ports or any male 5VDC connector on the Retail I/O Board (Ports 1, 2 or 5) or TeamCOMBO Board (Port 1 or 2).

5.10.3 A12/D12 Cable Summary

Note: In most cases, cable length will be the same

| | |
|--|--|
|  |  |
| <p>LCD Power cables for single LCDs:</p> <p>CA05951-3111 CBL D12 PWR Stacked/0.65M ()</p> <p>CA05951-3112 CBL D12 PWR Dispersed/2.0 M</p> <p>CA05951-3113 CBL D12 PWR Dispersed/5.0M</p> | <p>Audio Cables, 1 required for each speaker option:</p> <p>CA05951-3131 CBL D12 Audio/Stacked/0.65M</p> <p>CA05951-3132 CBL D12 Audio/Dispersed/2.0M</p> <p>CA05951-3133 CBL D12 Audio/Dispersed/5.0M</p> |
|  |  |
| <p>Digital cables, 1 required for each digital LCD:</p> <p>CA05951-3101 CBL D12 Stacked/0.65M</p> <p>CA05951-3102 CBL D12 Dispersed/2.0M</p> <p>CA05951-3103 CBL D12 Dispersed/5.0M</p> | <p>Analog Data Cables, 1 required for each Analog LCD:</p> <p>CA05951-5021 CBL A12 Analog Data/Stkd/0.65M</p> <p>CA05951-5022 CBL A12 Analog Data/Disp/2.0M</p> <p>CA05951-5023 -CBL A12 Analog Data/Disp/5.0M</p> |
|  |  |
| <p>Touch cables, 1 required for each touch screen:</p> <p>CA05951-3121 CBL D12 TCH Screen/Stked/0.65M</p> <p>CA05952-3122 CBL D12 TCH Screen/Disp/2.0M</p> <p>CA05951-3123 CBL D12 TCH Screen/Disp/5.0M</p> | <p>Dual LCD Power (Y) cables, 1 cable powers both the digital and the analog LCD ():</p> <p>CA05951-6061 CBL D12/A12 PWR Dual LCD/2.0M</p> <p>CA05951-6062 CBL D12/A12 PWR Dual LCD/5.0M</p> |
| <p>() For stacked dual LCDs, 2 required</p> | <p>(**) For stacked dual LCDs, two 0.65 meter cables can be used.</p> |
| <p>Notes:</p> <ul style="list-style-type: none"> • The application software will determine where the touch panels connect to the TeamPoS 2000. The touch cables can be connected to one of the PC board's COM ports or any male 5VDC connector on the Retail I/O Board (Ports 1, 2 or 5) or TeamCOMBO Board (Port 1 or 2). • TeamKey Cable Requirements: <ul style="list-style-type: none"> There are two TeamKey options: MSR only Keypad & MSR For either option , in addition to the listed cables, one of the following cables is required: 90000363 CBL D12 LCD KYB/0.8M 90000364 CBL D12 LCD KYB/2.0M 90000365 CBL D12 LCD KYB/5.0M | |

5.10.4. D12/A12 LCD Stand and Rotating Arm Assembly

Installing LCD Cables

1. Rotate arm completely to one side in order to feed the cables into the stand. This picture shows the metal bracket repositioned to allow for easier routing. To do this a screw is removed from one side only.

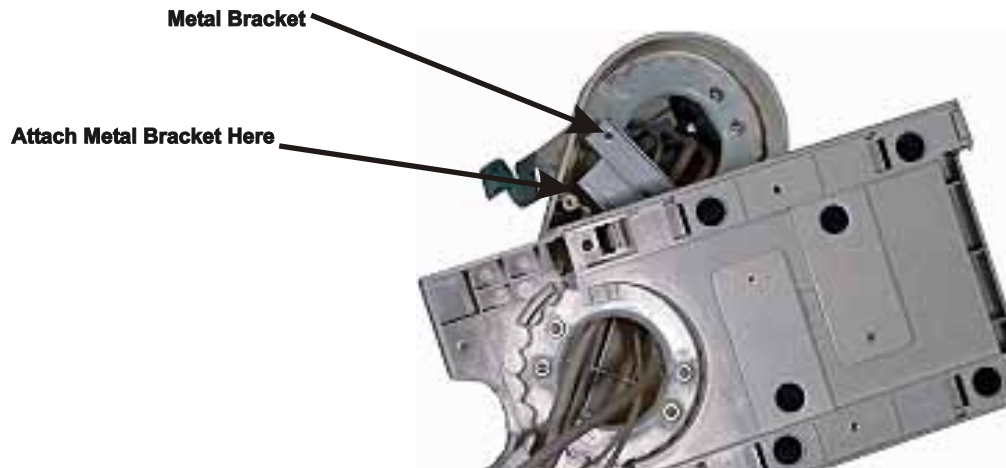

2. Install the speakers, if required, to the bottom of the LCD unit by using the two screws provided with the speaker.
3. Feed cables in from the bottom of the display assembly and through the arm, until the cable connectors are exposed at the LCD end. Check to make sure there is a cable for each feature.

| Cable Function | Digital LCD | Analog LCD |
|------------------|--------------------|--------------------|
| Power Cable | Mini-din connector | Mini-din connector |
| Data Cable | Custom cable | 15-pin VGA |
| Touch (optional) | 9-pin RS232 | 9-pin RS232 |
| Sound (optional) | Sound Connector | Not available |

4. After all cables are routed, install metal bracket using two screws. Installing the second screw requires rotating arm to the other side.

Installing LCD

Note: LCD monitors come with a protective film over the screen. Do not remove this film until installation is complete to avoid accidental damage to the surface.

1. Remove filler plate from the back of LCD.
2. Connect cables from rotating arm to the correct port on LCD.
3. Make sure that all cables are routed under the LCD cable guide.
4. Attach LCD to the rotating arm bracket by using screws (4).
5. Replace filler plate.

5.10.5 Model VF50 & VF50U Integrated Customer Display with D12/A12 LCD

Installing the Customer Display



1. Remove two screws from the bottom of the stand and slide off back end of LCD stand. **Retain screws.** Discard the back of the LCD stand.

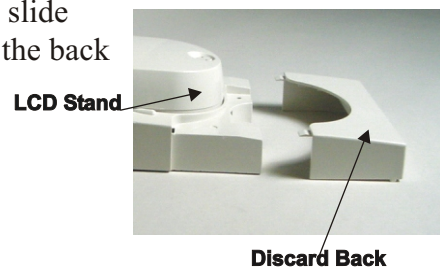

2. Slide the back end of the integrated display onto the LCD stand. There are two pole lengths, short and long. If short, secure back-end with two screws removed in Step 1.



If the integrated pole is long, it will come with two metal brackets. Install the metal brackets as shown and then secure metal brackets and integrated stand with two screws removed in Step 1. Please note there is a left and right bracket.

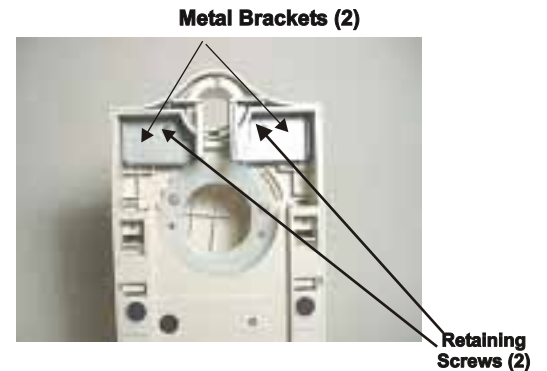

3. Route the display end of the cable (flat connector) through the base, the pole and the display tilter. Rotate the cable as required to get it through the pole. Install second half of the pole.
4. Remove the plastic connector cover from the display, by pulling up on the tab.
5. Connect the appropriate display cable flat connector to the display. Ensure the key tabs are down (display side) and locked into place.

VF50 connector
for USB connection

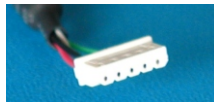

VF50 connector
for RS232 connection

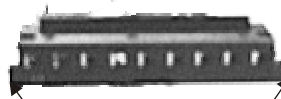

Key Tabs (down)

6. Attach the grounding wire to the display using the provided screw.

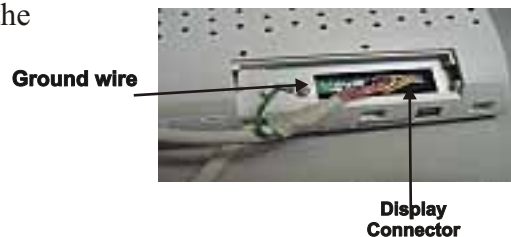

7. Route the cable as shown. Putting the heat shrink section in the connector opening will make it easier to install the display connector cover.



8. Install connector cover by inserting the right side tab (as viewed from the back of the display) into the display and then pushing down on the left side.

**Tilter Part Mounting Screws
(select one)**

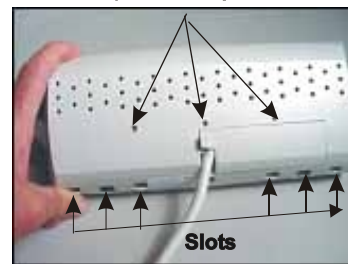

Note: The customer display can be mounted so that it is to the left, right or center of the pole, depending upon which display slots are selected.

9. Install the tilter part by first inserting the tilter tabs (3) into the display slots and then securing with a screw.
10. Insert the tilter into the pole and push it until it locks into place.
11. Mount display pole in the display pole stand. Align the opening of the pole (tape side) with the insert on the LCD stand back-end and push with sufficient pressure to lock the pole in place. **Do not remove the tape.**

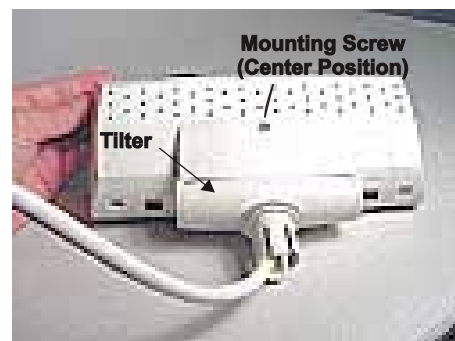

12. After the entire display unit is completed, set the unit on the *TeamPoS 2000* control unit, and slide it back onto the LCD brackets.

LCD Integrated Pole Mount



5.10.6 D12/A12 LCD with TeamKey Assembly



1. Install cables on the LCD (See LCD Cable Requirements, section 5.8.2.2).
2. Route all cables through the stand.

3. Install mounting bracket to back of LCD using the 4 screws provided. Two of the screws are longer than the other two. These are to be used on the thicker side (where the metal plate folds back on itself). In the picture below this is the right side.



4. Put LCD and Keypad/MSR unit together.
5. Attach back metal bracket to LCD and keypad/MSR and secure with 8 screws.



6. Attach rotation mechanism to back metal bracket using 4 screws (remove the rotation mechanism from stand, if it was previously installed).



- Slide back panel into place (2 taps) and secure with 1 screw.

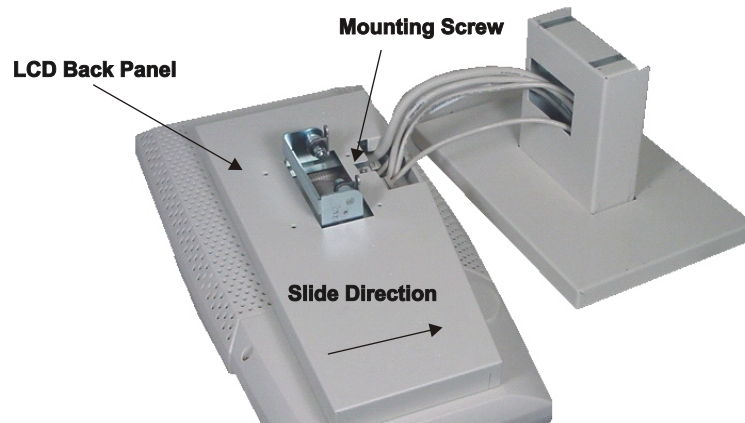

- Install LCD assembly on the stand, using four screws.



- Install rotation mechanism cover (flat side on top) and secure with 2 screws.



10. Slide the stand vertical cover into place and secure with one screw on the underside of the stand.

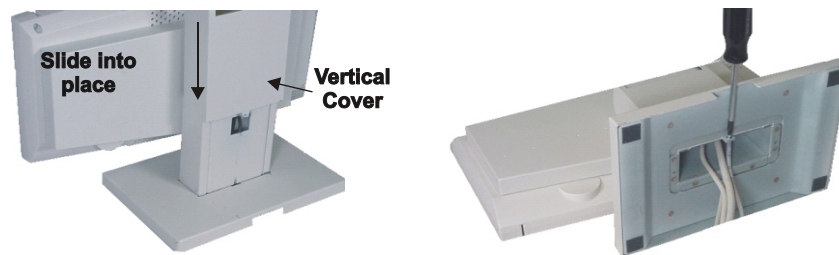

11. Route cables through the check-stand/counter as required.
12. Connect cables to the TeamPoS 2000 control unit.
13. Install LCD with stand in the check-stand/counter.
14. When all peripherals are installed start control unit, (see General Operations, Chapter 6).

5.10.7 Models D12 and A12 LCD, 12.1" Adjustments

The following graphics show LCD adjustments for all models. Adjust the following, where appropriate:

1. Adjust the brightness.
2. Adjust the sound volume to the maximum (digital versions only).
3. Turn ON the unit; see Powering ON (see section 6.1.2).

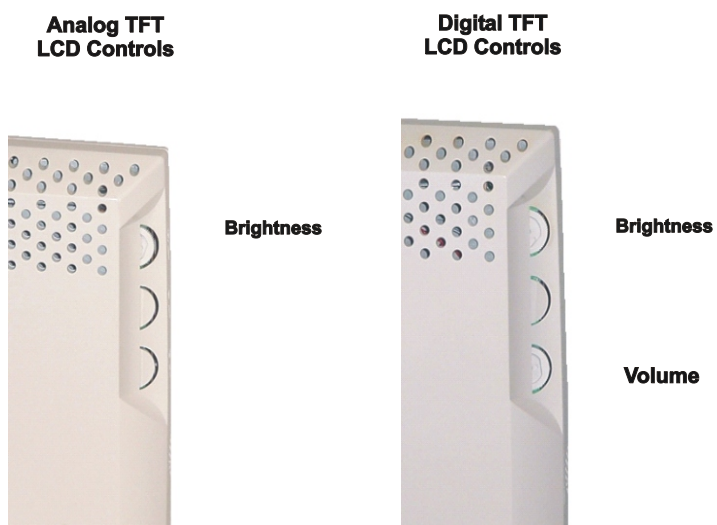

5.10.8 Model VF50 and VF50U Customer Display Settings

5.10.8.1 Customer Display Settings

Customer display default settings for both the VF50 and VF50U conform to the international font table. See the following table to change to ESC/PoS mode:

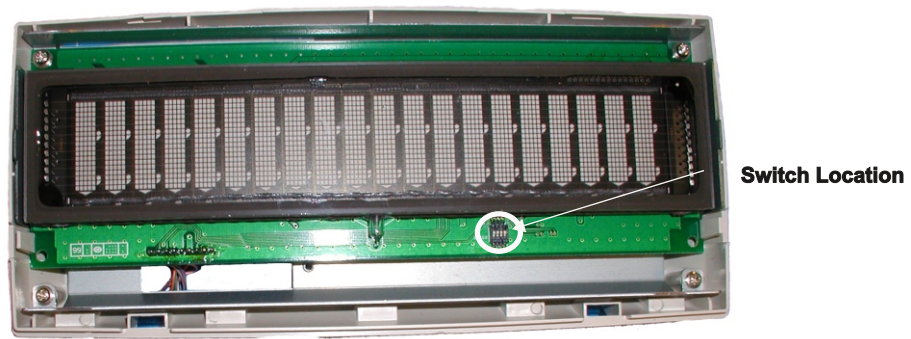

5.10.8.2 VF50U Switch Definition

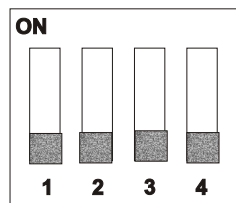

VF50U Default Switch Settings

| No. | ON | OFF |
|---|---|------------------------|
| 1 | Japanese font table (in FJ mode) | Standard font table |
| 2 | Comm 8 | Comm 7 |
| 3 | Esc Mode | FJ Mode |
| 4 | Display on Power Up 'Program Loading...Please Wait | No Display on Power Up |
| Note: All switches in the "on" position initiates test mode when VF50U is first powered up. | | |

VF50U Switch Configuration Matrix

| 1 | 2 | 3 | 4 | Font | Test | VFD ID | FJ/ESC | Loading Message |
|---|-----|-----|-----|----------|------|------------------|--------|-----------------|
| OFF | OFF | OFF | OFF | English | None | Customer (COM7) | FJ | OFF |
| OFF | OFF | OFF | ON | English | None | Customer (COM7) | FJ | ON |
| OFF | OFF | ON | OFF | English | None | Customer (COM7) | ESC | OFF |
| OFF | OFF | ON | ON | English | None | Customer (COM7) | ESC | ON |
| OFF | ON | OFF | OFF | English | None | Operator (COM 8) | FJ | OFF |
| OFF | ON | OFF | ON | English | None | Operator (COM 8) | FJ | ON |
| OFF | ON | ON | OFF | English | None | Operator (COM 8) | ESC | OFF |
| OFF | ON | ON | ON | English | None | Operator (COM 8) | ESC | ON |
| ON | OFF | OFF | OFF | Japanese | None | Customer (COM7) | FJ | OFF |
| ON | OFF | OFF | ON | Japanese | None | Customer (COM7) | FJ | ON |
| ON | OFF | ON | OFF | Japanese | None | Customer (COM7) | ESC | OFF |
| ON | OFF | ON | ON | Japanese | None | Customer (COM7) | ESC | ON |
| ON | ON | OFF | OFF | Japanese | None | Operator (COM 8) | FJ | OFF |
| ON | ON | OFF | ON | Japanese | None | Operator (COM 8) | FJ | ON |
| ON | ON | ON | OFF | Japanese | None | Operator (COM 8) | ESC | OFF |
| ON | ON | ON | ON | - | TEST | - | - | - |
| Note: During bootup, display shows "Program loading, please wait." if switch position #4 is on. | | | | | | | | |

5.10.8.3 VF50 Switch Definition

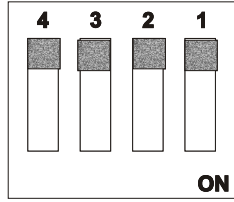

VF50 Default Switch Settings

| No. | ON | OFF |
|---|--|--|
| 1 | Japanese font table (in FJ mode) | Standard font table |
| 2 | Self-test mode | Normal Mode |
| 3,4 | 3: OFF 4: OFF 3: ON 4: OFF 3: OFF 4: ON 3: ON 4: ON | FJ mode - Default ESC mode Reserved Reserved |
| <p>Note: All switches are shipped from the factory in the "off" position.</p> | | |

5.11 Cash Drawers

Cash Drawers can be either stacked or dispersed. This section shows the stacked configuration and explains how to set up the unit. When a stacked configuration is shipped it is set up as follows:

1. Set the drawer in position.
2. When stacking the main unit on the drawer, confirm that the metal lock on the drawer fits into the groove on the bottom of the main unit (Models TP10 and MP5).

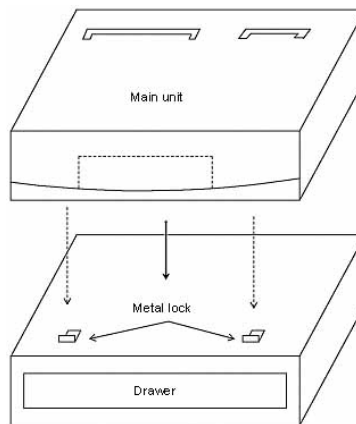

Note: When installing mounting screws, do not over-tighten.

Installing the brackets merely requires placing the bracket on the appropriate screw holes and securing with two screws provided for each bracket. To prevent dust and moisture penetration, apply a screw-hole cover label from the provided label sheet over each screw hole on the top cover where a bracket will not be used. For dispersed configurations, all holes are covered.

5.12 Connecting Retail I/O, TeamCOMBO & TeamUSB Board Cables

The software application program determines which connector corresponds to each PoS peripheral.

1. You should have instructions that define which PoS peripheral connects to which I/O port.
2. Connect, as appropriate, the PC components such as keyboard, LAN, etc.
3. Connect AC power.

Note: Allocation of connectors at the rear is shown below. Each connector is to be used for a particular purpose. Do not connect to the wrong connector when connecting I/O devices. Once the correct connections are made, use the labels from the label sheet supplied with the unit to make future connections easier. Colored labels correspond to PC ports and numbered labels correspond to PoS peripheral ports.

TeamPoS 2000 with Retail I/O Board Connector Layout with A Motherboard

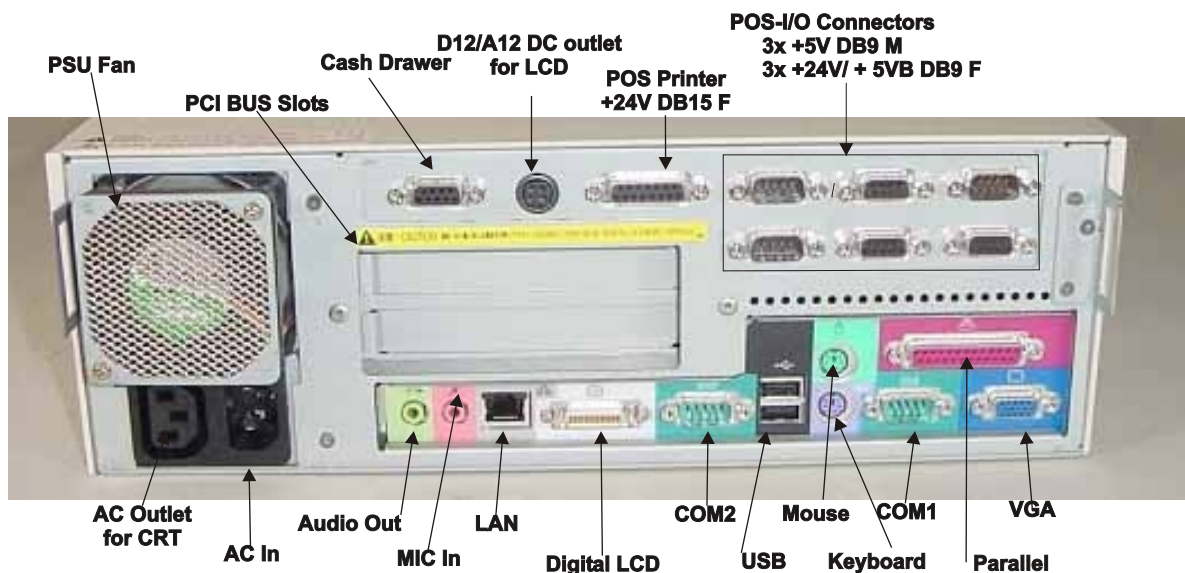

5.12.1 TeamPoS 2000 with Retail I/O Board Connector Layout-A Motherboard

| | Name | Definition |
|--------------|-------------------|--------------------------|
| PoS Ports | 1 | PoS Peripheral Port #1 |
| | 2 | PoS Peripheral Port #2 |
| | 3 | PoS Peripheral Port #3 |
| | 4 | PoS Peripheral Port #4 |
| | 5 | PoS Peripheral Port #5 |
| | 6 | PoS Peripheral Port #6 |
| | PTR | Printer |
| | LCD PWR | LCD Power |
| | DRW | Cash Drawer |
| | PC Board Ports | KB |
| M | | Mouse |
| COM1 | | Communications Port #1 |
| COM2 | | Communications Port #2 |
| LPT | | Parallel Interface |
| VGA | | Analog Video |
| LCD | | Digital LCD Video |
| USB | | Universal Serial BUS (2) |
| MIC | | Microphone/Audio In |
| SPEAKER | | Speaker/Audio Out |
| LAN | | Local Area Network |

TeamPoS 2000 with TeamCOMBO Board Connector Layout with A Motherboard

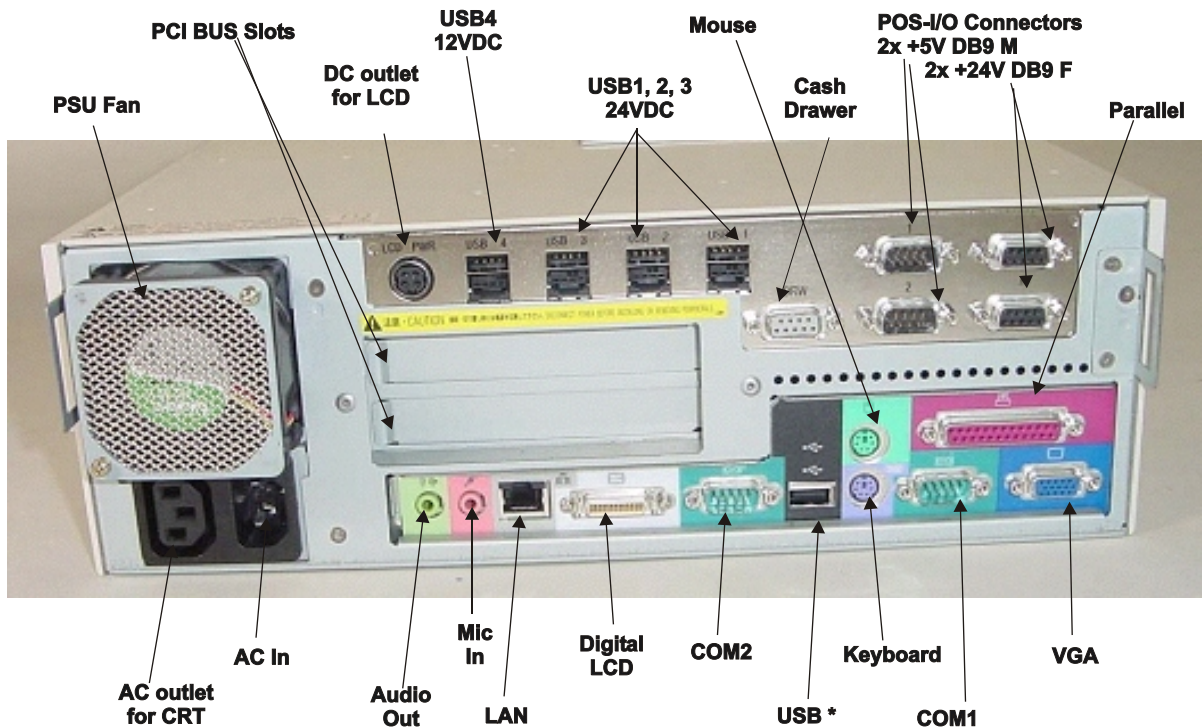

Note: When the TeamCOMBO board is installed, one of the USB ports on the motherboard becomes unavailable because it is used as a hub for the TeamCOMBO board. A blanking label is installed over the top USB port connector on the back of the motherboard as shown.

Note: There are two versions of the TeamCOMBO board:

1. PIN #90000276
2. PIN #90001036

PIN # 90000276 does not support powering the D15 LCD. A separate power supply unit (PSU) is required.

5.12.2 TeamPoS 2000 with TeamCOMBO Board Connector Layout-A Motherboard

| | Name | Definition |
|-------------------|---------|--------------------------|
| PoS Ports | 1 | PoS Peripheral Port #1 |
| | 2 | PoS Peripheral Port #2 |
| | 3 | PoS Peripheral Port #3 |
| | 4 | PoS Peripheral Port #4 |
| | USB1 | USB, 24VDC |
| | USB2 | USB, 24VDC |
| | USB3 | USB, 24VDC |
| | USB4 | USB, 12VDC |
| | LCD PWR | LCD Power |
| | DRW | Cash Drawer |
| PC Board Ports | KB | Keyboard |
| | M | Mouse |
| | COM1 | Communications Port #1 |
| | COM2 | Communications Port #2 |
| | LPT | Parallel Interface |
| | VGA | Analog Video |
| | LCD | Digital LCD Video |
| | USB | Universal Serial BUS (1) |
| | MIC | Microphone/Audio In |
| | SPEAKER | Speaker/Audio Out |
| | LAN | Local Area Network |

Note: Once installation is complete, the unit should be left plugged in for 24 hours to allow lead acid battery to fully charge.

TeamPoS 2000 with TeamUSB Board Connector Layout with A Motherboard

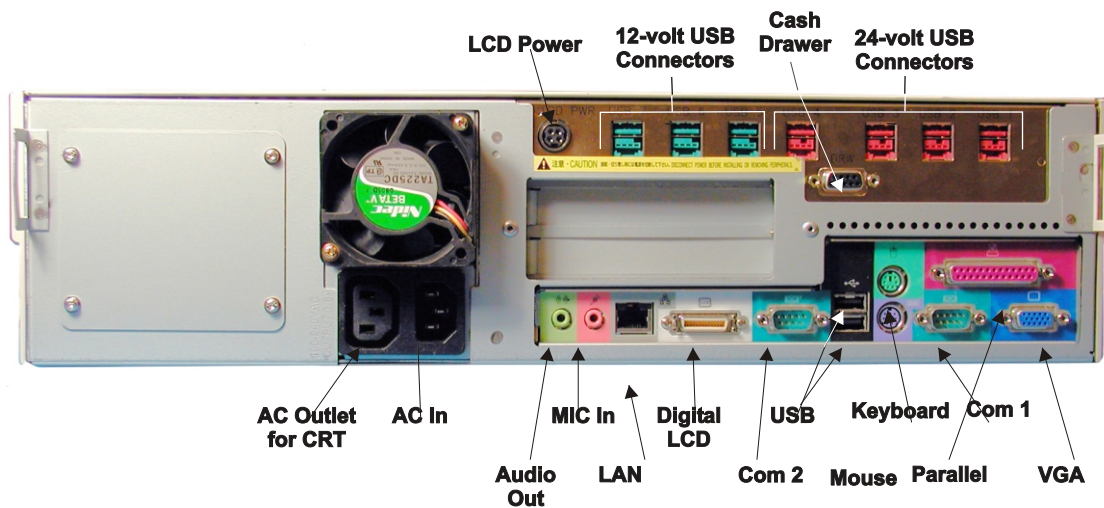

When the TeamUSB board is installed, the top USB port becomes unavailable because it is used as a hub for the new I-O board. A blanking label covers the port used.

5.12.3 TeamPoS 2000 with TeamUSB Board Connector Layout with A Motherboard

| | Name | Definition |
|--------------|--------------------|---------------------------|
| PoS Ports | USB1 | USB, 24VDC |
| | USB2 | USB, 24VDC |
| | USB3 | USB, 24VDC |
| | USB4 | USB, 24VDC |
| | USB5 | USB, 12VDC |
| | USB6 | USB, 12VDC |
| | USB7 | Not used on A motherboard |
| | LCD PWR | LCD Power |
| | DRW | Cash Drawer |
| | PC Board Ports | KB |
| M | | Mouse |
| COM1 | | Communications Port #1 |
| COM2 | | Communications Port #2 |
| LPT | | Parallel Interface |
| VGA | | Analog Video |
| LCD | | Digital LCD Video |
| USB | | Universal Serial BUS (1) |
| MIC | | Microphone/Audio In |
| SPEAKER | | Speaker/Audio Out |
| LAN | Local Area Network | |

TeamPoS 2000 with TeamUSB Board Connector Layout with M Motherboard

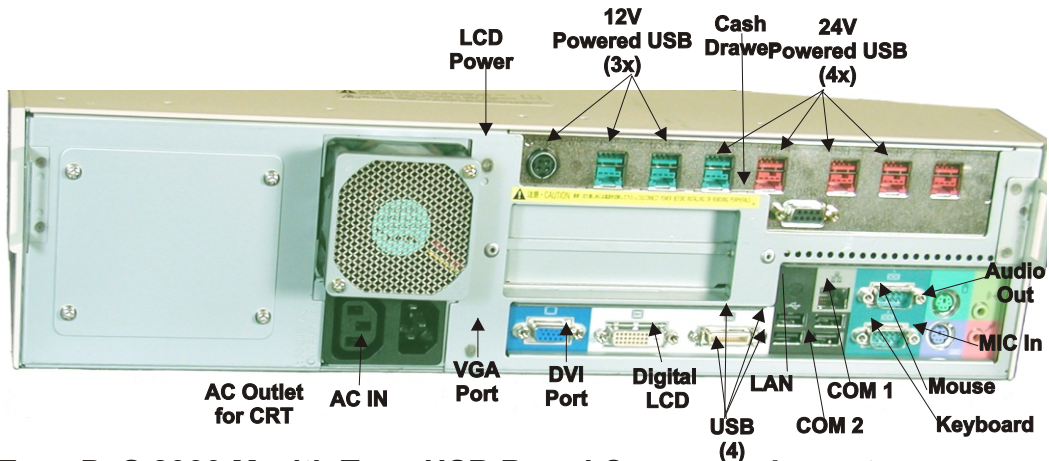

5.12.4 TeamPoS 2000 M with TeamUSB Board Connector Layout with M Motherboard

| | Name | Definition |
|-----------|----------------|--|
| PoS Ports | USB1 | USB, 24VDC |
| | USB2 | USB, 24VDC |
| | USB3 | USB, 24VDC |
| | USB4 | USB, 24VDC |
| | USB5 | USB, 12VDC |
| | USB6 | USB, 12VDC |
| | USB7 | USB, 12VDC |
| | LCD PWR | LCD Power |
| | DRW | Cash Drawer |
| | PC Board Ports | KB |
| M | | Mouse |
| COM1 | | Communications Port #1 |
| COM2 | | Communications Port #2 |
| LPT | | Optional --uses add-in card expansion slot opening |
| VGA | | Analog Video |
| LCD | | Digital LCD Video |
| USB | | Universal Serial BUS (4) |
| MIC | | Microphone/Audio In |
| SPEAKER | | Speaker/Audio Out |
| LAN | | Local Area Network |

Chapter 6 GENERAL OPERATIONS

Note: The procedures in this chapter are intended for **store personnel**. The procedures in succeeding chapters are for **authorized service personnel only**.

6.1 System Operations

This section contains general and periodic care and maintenance, and power ON and OFF procedures for the TeamPoS terminals.

6.1.1 General Care and Maintenance

General cleaning of the terminal, peripherals, and MSR is required on a regular basis. In particular, dust must be removed from internal components, air vents, fans, and exhaust screens to allow sufficient airflow to maintain proper internal operating temperatures. Printers must also have paper dust and other foreign matter removed regularly to maintain proper printer operation. The frequency of this cleaning depends on installed environments. Lack of this cleaning will greatly reduce equipment reliability.

To achieve the MTBF of 500,000 passes for the MSR, cleaning with an MSR cleaner card must be performed approximately every 1,000 passes.

To keep the terminal and its peripherals in good working condition, follow the guidelines in this section.

1. Wipe the terminal and peripherals with a clean, soft cloth, dampened with water and mild soap. Never use abrasive pads or cleansers.
2. Vacuum the paper wells of the receipt and journal printers to remove paper particles and dust.
3. Clean the MICR mechanism on the printer once a month or after every 6,000 checks. See cleaning instructions.
4. If the keyboard or LCD has the MSR option installed, pass a magnetic stripe reader cleaner through the magnetic stripe reader to remove dust particles from the reader. The cleaner is a card covered with cloth on one side. Pass the card through the reader with the cloth side facing the MSR head. An embossed arrow on the keyboard shows where the MSR head is located.

Never remove covers from the control unit and peripherals while power is connected.

Keep the rear cover of the TeamPoS 2000 terminal installed at all times unless the terminal is being serviced. The cover protects the cable connections and ensures adequate clearance for proper ventilation.

Make sure all cable connectors are securely installed on the terminal and peripherals to prevent the cables from being accidentally pulled off. Disconnecting and connecting cables (except USB cables) to the terminal while the power is on could cause damage to the terminal and its peripherals.

Do not expose the terminal to liquids. Although the units are designed to prevent liquids from entering the internal components, liquids should be kept away from the terminal.

6.1.2 Power ON and OFF Sequence

This section presents the general procedures for powering the TeamPoS 2000 control unit ON and OFF. The instructions in this section assume that the terminal, operating system, and the application software have been installed. For any additional power on and off procedures dictated by the retail application, refer to the manuals provided with your PoS and application software.



Caution: With the exception of USB peripherals, never remove or connect any peripheral while power is on its port. To avoid damage to the control unit and peripherals, when connecting and disconnecting peripherals from the Retail I/O or TeamCOMBO Board's RS232 ports, turn power OFF with the ports OFF switch, the TeamPoS 2000 power switch (in the front of the unit) or by disconnecting AC power.

6.1.3 Powering ON

1. Make sure all peripherals are securely connected to the control unit.
2. Make sure the power cord is plugged into the power source.
3. Lift the plastic switch cover at the front of the control unit.
4. Press the ON switch.
5. Confirm the power/battery status LED is ON and not blinking, indicating the successful completion of power-up diagnostics.

Any hardware errors detected on power up will appear on the operator display (CRT or LCD). Note that the Model VF50 two-line alphanumeric display does not display error messages.

Note: Some peripherals, such as scanners and scales, may be separately powered. Check the peripheral manuals for instructions for these peripherals.

6.1.4 Powering OFF

1. Lift the plastic switch cover.
2. Press the ON/OFF switch.

Note: Depending on BIOS setup, a momentary depression of the switch may signal the application to shut the unit down, which could take a few minutes. If power is not immediately turned off, either wait for the application to shut the unit down, or keep the switch depressed for approximately 4 seconds. For proper shutdown procedures, see the application software documentation.

This page intentionally left blank.

Chapter 7 MAINTENANCE



Caution: To prevent electric shock, confirm that the AC cable is removed from the AC outlet anytime the covers are removed. Be sure to observe all ESD precautions and power off procedures.

Only trained personnel must perform the following:

1. Vacuum all ventilation passageways on the control unit and peripherals. Ensure that these passageways are open and free of dust and other debris that could restrict airflow.
2. Check the CPU chassis fan and PSU fan for proper operation annually. See BIOS settings for typical fan speeds. If fan speed is approaching the low end, the fan should be replaced. Fan speeds can be found under 'Clock and Sensor' for the A motherboard and under 'Hardware Health Configuration' for the M motherboard.
3. Replace lead acid batteries every three years.
4. If the model DT50/DT50II has the MICR option, check the function of, and clean, the MICR annually.

7.1. Power ON and OFF Sequence

This section presents the general procedures for powering ON and powering OFF the *TeamPoS 2000* control unit. The instructions in this section assume that the terminal, operating system, and the application software have been installed. For any additional power-up procedures dictated by the retail application, refer to the manuals provided with the application software.



Caution: **With the exception of USB peripherals, never disconnect or connect a peripheral while power is on its port.** To avoid damage to the control unit and peripherals, when connecting and disconnecting peripherals from the Retail I/O or TeamCOMBO Boards, turn power OFF with the ports OFF switch (see section 1.2), the TeamPoS 2000 power switch in the front of the unit or by disconnecting AC power.

7.1.1 Powering ON

Make sure all peripherals are securely connected to the control unit.

1. Make sure the power cord is plugged into the power source.
2. Lift the plastic switch cover at the front of the control unit.
3. Press the ON switch.
4. Confirm the power/battery status LED is lit solid, indicating the successful completion of power-up diagnostics.

Note: Some peripherals, such as scanners and scales, may be separately powered. Check the peripheral manuals for instructions on powering on these peripherals.

Any hardware errors detected on power up will appear on the operator display (LCD or CRT). Note that the model VF 50 two-line alphanumeric display does not display error messages.

Note: Depending on setup, a momentary depression of the switch may signal the application to shut the unit down, which could take a few minutes. If power is not immediately turned off, either wait for the application to shut the unit down, or keep the switch depressed for approximately 4 seconds. For proper shutdown procedures, see the application software documentation.



Caution: Be sure to observe all ESD precautions and power OFF procedures.

When replacing the PC board, ensure AC power cord is removed/unplugged before any maintenance is performed! The power unit of this equipment always supplies electric power to maintain the equipment in standby condition. Therefore, when the equipment is connected with an AC outlet, a part of the main board circuit is charged even if the equipment power is OFF.

7.1.2 Powering OFF

1. Lift the plastic switch cover.
2. Press the ON/OFF switch.

Note: For proper shutdown procedures, see the application software documentation.

7.2 PC Board Replacement



Caution: To prevent electric shock, confirm that the AC cable is removed from the AC outlet anytime the covers are removed. Be sure to observe all ESD precautions and power off procedures.

The following instructions apply for both the M & the A motherboards.

1. Remove the front cover (see section 5.1.1).
2. Remove the side cover (left) (see section 5.1.2).
3. Disconnect all peripheral cables connected to the PC board.
4. Locate the lever below the PC board and pull towards you.

5. Remove the PC board.



6. Insert the replacement PC board with the plastic rails (underside the motherboard), into the rail guides on the chassis.

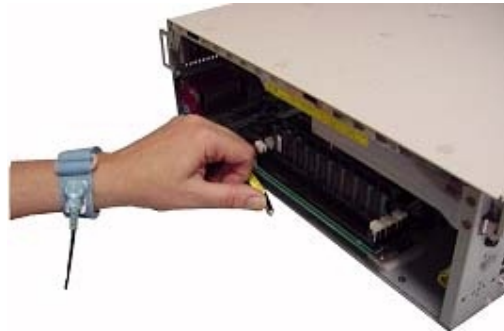

7. Insert the PC board with the lever at 90° to chassis, until it meets the mating connector (nearly fully inserted). Use the lever to fully seat the motherboard.
8. Reconnect all peripheral cables that were connected to the PC board.
9. On completion of insertion, attach the left side cover to the equipment, by sliding back and locking into place. Also, reattach the front cover.
10. The system CMOS must be set after replacing the PC board. Be sure to execute the BIOS setup operation on the BIOS setup screen. (For BIOS setup procedures, see Chapter 8, "BIOS Setup Procedures.")
11. If this replacement is an upgrade, install the upgrade label that comes with the PC Board upgrade kit on the side of the unit near the serial number (see section 5.2.1).

7.3 M Motherboard Layout

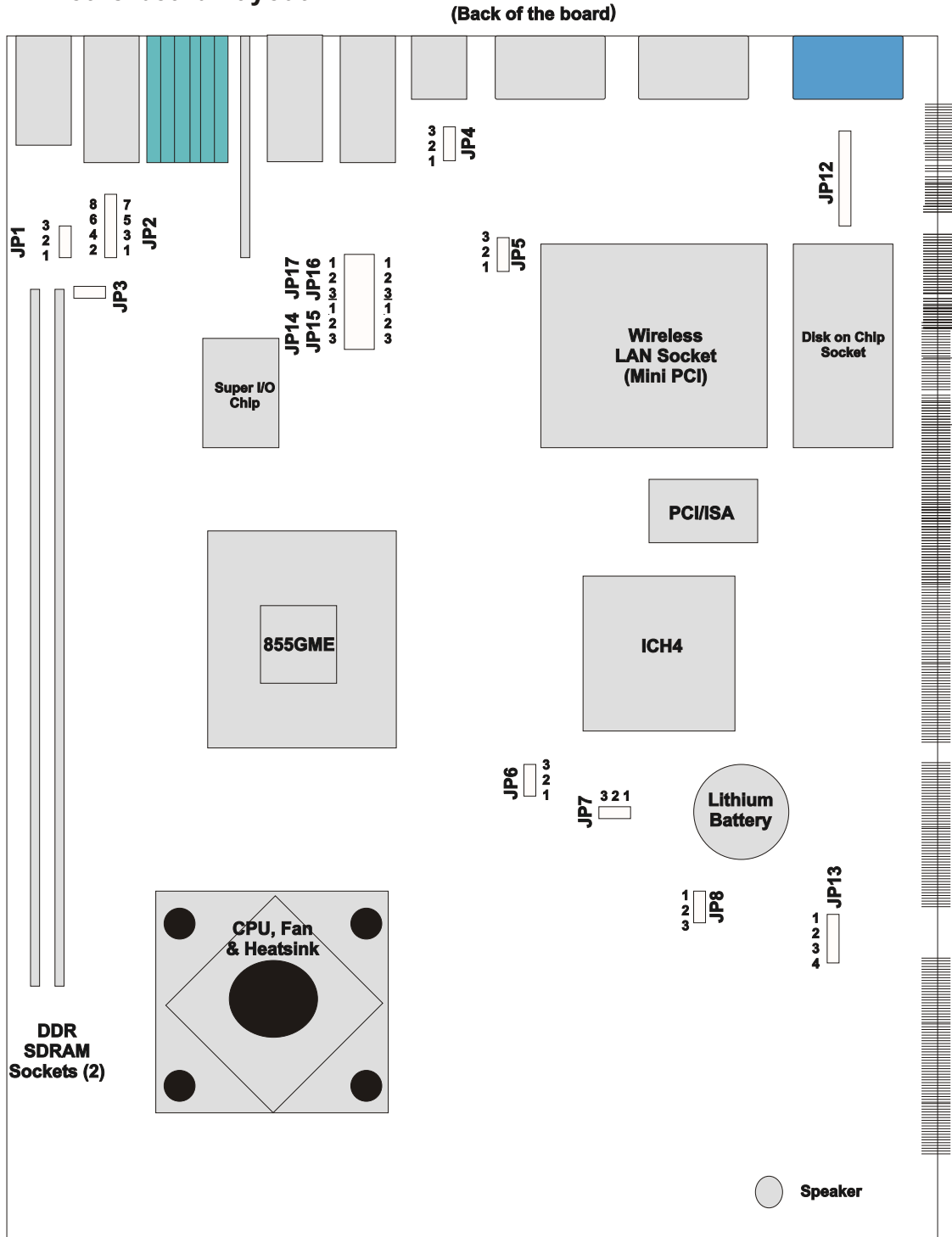

7.3.1 M Motherboard Settings

| No. | Pin Name | Meaning | Default Settings |
|-----|----------|--|------------------|
| 1 | JP1 | KB/MS Power Select 1-2 +5V 2-3 +5V SBY | 1-2 |
| 2 | JP2 | Power COM Port Setting 1-2 RI 3-4 Powered COM (+12V) 5-6 RI 7-8 Powered COM (+12V) | 1-2 5-6 |
| 3 | JP3 | PC Beep Jumper Setting H/W Monitor PC Beep to Line-out 1-2 Enable 2-3 Disable | 1-2 |
| 4 | JP4 | USB 1&2 Power Select 1-2 +5V 2-3 +5V SBY | 1-2 |
| 5 | JP5 | KB/MS Power Select 1-2 +5V 2-3 +5V SBY | 1-2 |
| 6 | JP6 | VCCA Power Select 1-2 1.8V Banias 2-3 1.5V Dothan | 1-2 |
| 7 | JP7 | Clear CMOS 1-2 Normal 2-3 Clear | 1-2 |
| 8 | JP8 | CPU Clock Setting 1-2 100MHz 2-3 133MHz | 1-2 |
| 9 | JP12 | Disk on Chip 2000 Jumper Setting 15-16 0DE000H - 0DFFFFH | 15-16 |
| 10 | JP13 | PCI AUX Power Select 1-2 No Power 2-3 3.3VDUAL 3-4 3.3V | 2-3 |

| No. | Pin Name | Meaning | Default Settings |
|------------|-----------------|--|-------------------------|
| 11 | JP14 | DVOB 12C Bus Setting 1-2 M12CDATA 2-3 DDCPDATA | 2-3 |
| 12 | JP15 | 12CCLK 1-2 M12CCLK 2-3 DDCCLK | 2-3 |
| 13 | JP16 | DVI 12C Bus Setting 1-2 MDVIDATA 2-3 MDDCDATA | 1-2 |
| 14 | JP17 | DVI 12C Bus Setting 1-2 MDVICLK 3-4 MDDCCLK | 1-2 |

7.3.2 Picture of M Motherboard

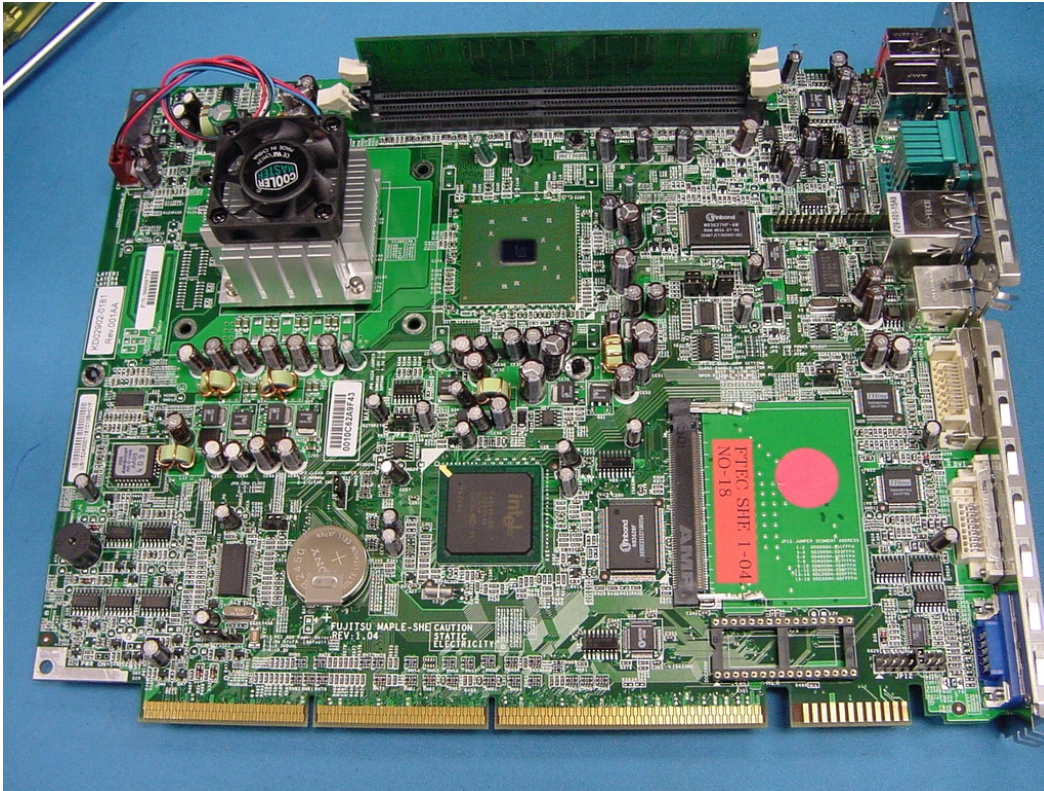

7.3.3 A Motherboard Layout

The following figure shows jumper positions. Explanations are provided on the following pages. When setting and exchanging the main board, be sure settings are as follows (default settings), before operation.

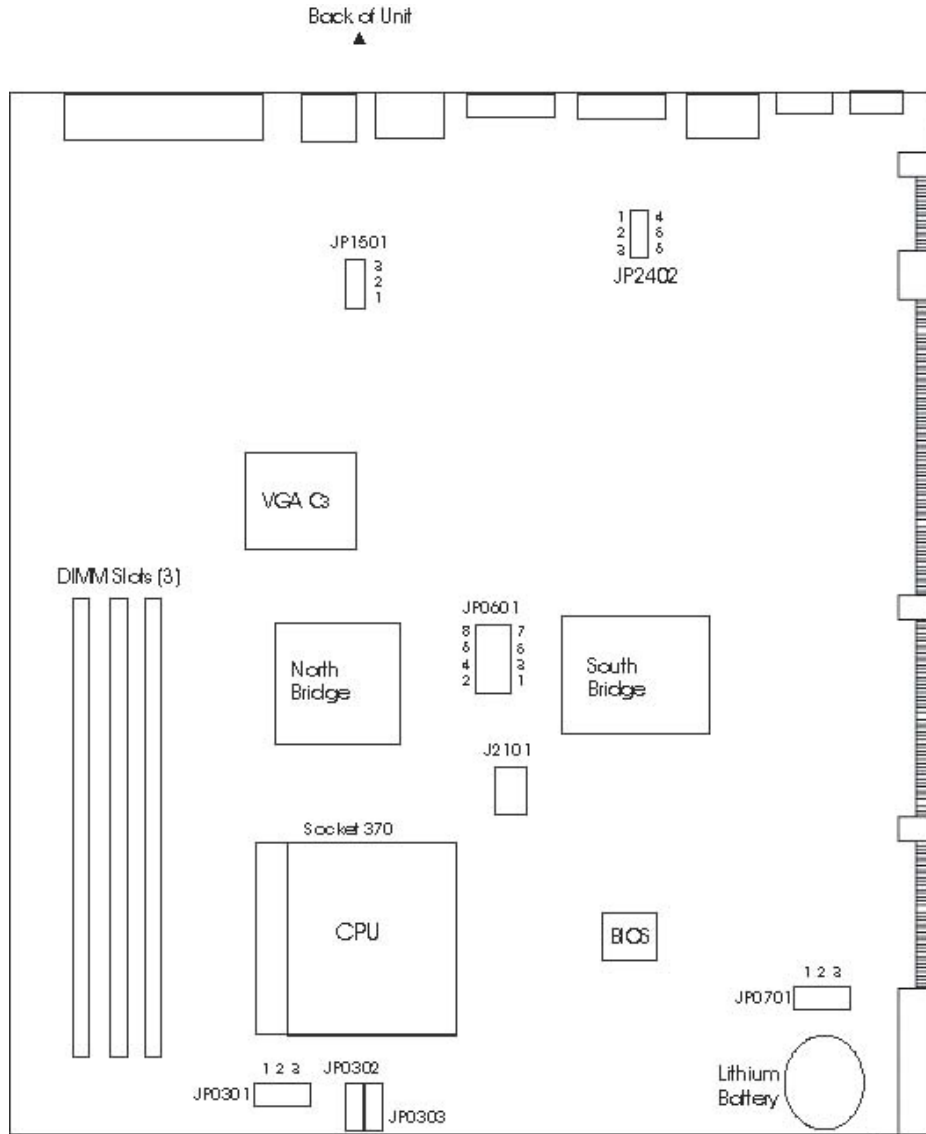

7.4 A Motherboard Settings

| No. | Pin Name | Meaning | Default Settings |
|-----|----------|---|---|
| 1 | JP0601 | CPU frequency multiplier - Not Used | 1-2 Short 3-4 Open 5-6 Open 7-8 Open |
| 2 | JP0301 | See 1st note below. Select either Pentium III or Celeron. (Voltage setting) Jumper 1-2: Pentium III and 566 MHz Celeron (Coppermine core) Jumper 2-3: Celeron 433 (Mendocino core) | Depends on CPU |
| 3 | JP0302 | <u>Select either Coppermine or Mendocino CPU</u> SHORT: Pentium III & 566 MHz Celeron (Coppermine core) OPEN: 433 MHz Celeron (Mendocino Core) | Depends on CPU |
| | JP0303 | SHORT: Pentium III & 566 MHz Celeron (Coppermine core) OPEN: 433 MHz Celeron (Mendocino Core) | |
| 4 | JP0701 | Deleting the CMOS RAM password 1-2: Normal 2-3: Password deleted | 1-2 |
| 5 | JP1501 | Keyboard/mouse power sources 1-2: Normal 5 V system 2-3: Standby 5 V system (Default Test Only) | 1-2 |
| 6 | JP2402 | See 2nd note below. DC output mode at AC input (see note 2 that follows) 5-6, 2-3: POS mode 4-5, 2-3: General PC mode 5-6, 1-2: AC_ON mode (not used) | 5-6, 2-3 |

Note: **Coppermine** is also referred to as 0.18mm technology. The 600 and 800 MHz and 1GHz Pentium III and 566MHz Celeron incorporate Coppermine technology. **Mendocino** is also referred to as 0.25mm technology. The 433MHz Celeron incorporates Mendocino technology.

Note: When power is **OFF** and then turned **ON**:

1. POS mode boots up automatically.
2. General PC Mode stays **OFF** until turned **ON** by power switch
3. AC-ON mode is not used.

7.5 Lead Acid Battery Replacement



Caution: To prevent electric shock, confirm that the AC cable is removed from the AC outlet anytime the covers are removed. Be sure to observe all ESD precautions and power off procedures. Dispose of the battery in accordance with local regulations for lead acid battery disposal.

1. Remove the front cover (see section 5.1.1).



2. Remove the metal cover plate on the front-right side of unit over the panel with LEDs and Power Switch. It is secured with a screw in the center of the top cover.
3. Disconnect the cable connector of the lead acid battery from the cable connector with a BATT label. On the new replacement battery, use indelible ink to write the date the battery was replaced using this format: "Battery Replaced DD/MM/YY".



4. Mount the new battery in the unit. Connect the battery cable with the connector labeled BATT.
5. Attach the cover plate.
6. Attach the front cover.

7.6 Power Supply Unit Replacement



Caution: Confirm that the external power source is 100-240 VAC before applying power to the unit. To prevent electric shock, confirm that the AC cable is removed from the AC outlet anytime the covers are removed. Be sure to observe all ESD precautions and power off procedures.

1. Unplug the AC power cord.
2. Remove the front cover (see section 5.1.1).
3. Remove the battery (see section 7.5).
4. Remove the top cover (see section 5.1.4).



5. Remove the disk cage stabilizer shown here.
6. Disconnect the three riser card cables, in the area shown below.

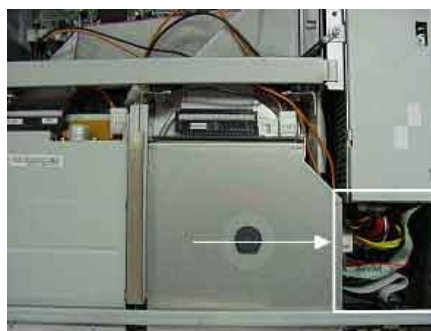

7. Disconnect the power cables from the hard disk drives, floppy drive, and media player if installed. Route cables back towards the power supply.
8. Free all cables connected to the power supply unit, and place them on the top of the device.
9. Remove the two screws securing the power supply unit.
10. While facing the front of the device, slide the power supply unit forward. Then, lift and remove the unit.



11. To remount the power supply unit, reverse the removal procedure.

7.7 HDD Kit Replacement



Caution: To prevent electric shock, confirm that the AC cable is removed from the AC outlet anytime the covers are removed. Be sure to observe all ESD precautions and power off procedures.

1. Remove the front cover (see section 5.1.1).
2. Remove the metal EMI shield from the front of the hard disk unit.
3. Disconnect the power and signal cables from the applicable hard disk, pull the black pull cord (indicated by the arrow in the figure below), pulling the hard disk out.

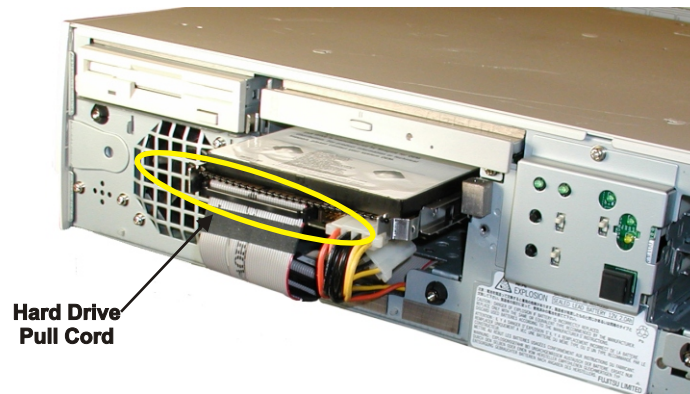

The HDD kit has setting pins similar to connector shown on the following page. Make sure the jumper settings on the new drive match before replacing with the new HDD.

Caution: Ensure replacement drive settings match the settings of the removed drive

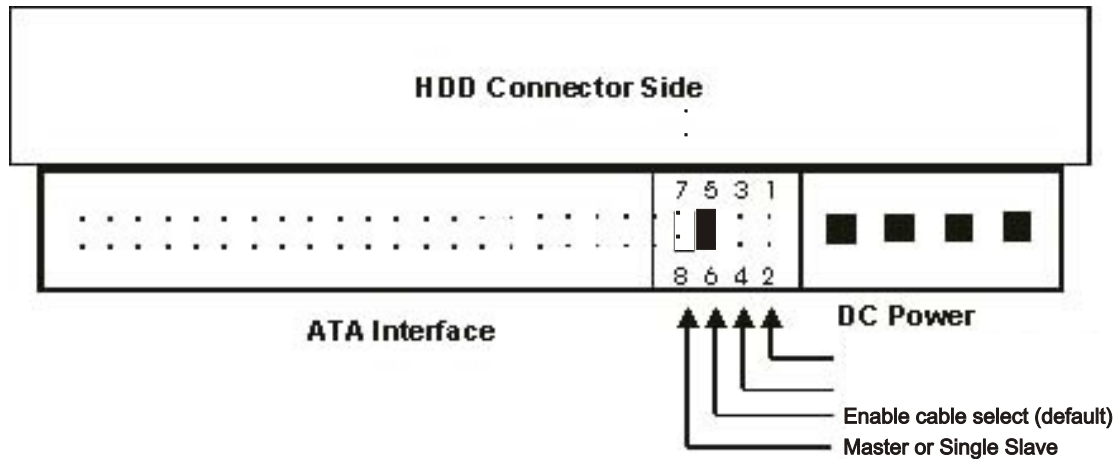

4. To mount the hard disk again, reverse the removal procedure. When mounting the hard disk again, be sure to insert the drive into the unit as far as it will go.
5. If this is an upgrade or the addition of a second drive, install the upgrade label that comes with the HDD upgrade kit on the side of the unit near the serial number. See section 5.2.1.

Note: Standard hard drive is a Seagate. HDDs from other manufacturers will have different jumper settings. Check the manufacturer's data sheet for the correct jumper settings.

7.8 FDD Unit Replacement



Caution: To prevent electric shock, confirm that the AC cable is removed from the AC outlet anytime the covers are removed. Be sure to observe all ESD precautions and power off procedures.

1. Remove the top cover (see section 5.1.4).
2. Disconnect the power and signal cables from the back of the floppy disk drive.



3. Press the brackets at both ends of the floppy disk drive inwards from the front of the device, and then pull the drive out to remove it.



4. To mount the floppy disk drive again, reverse the removal procedure.



5. If this is an upgrade, install the upgrade label that comes with the Floppy Disk Drive upgrade kit on the side of the unit near the serial number. See section 5.2.1.

7.9 CD-ROM/CD-Read/Write/DVD (Media Player) Kit Replacement



Caution: To prevent electric shock, confirm that the AC cable is removed from the AC outlet anytime the covers are removed. Be sure to observe all ESD precautions and power off procedures.

1. Remove the front cover (see section 5.1.1).
2. Remove the top cover (see section 5.1.4.)
3. Disconnect power and signal cables from the back of the unit.



4. While facing the front of the device, remove the one mounting screw from the lower right part of the unit, and then pull the media player out to remove it.
5. To reinstall the media player drive, reverse the removal procedure.

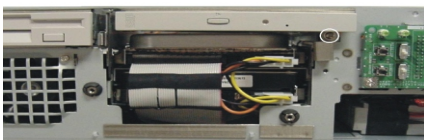

Note: Ensure guides on left hand side of media player align above chassis guides and ensure tray opens freely after installation of front door..

7.10 Operator Panel



Caution: To prevent electric shock, confirm that the AC cable is removed from the AC outlet anytime the covers are removed. Be sure to observe all ESD precautions and power off procedures.

1. Remove the front cover (see section 5.1.1).
2. Remove the cover metal plate on the front-right side of unit and over the panel with the LED's and power switch. It is secured with a screw in the center of the top cover.



3. Remove the screw at the lower left of the operator panel, and then disconnect the two (2) cables from the back of the board to remove the board.



4. To mount the operator panel again, reverse the removal procedure.

7.10.1 Operator Panel Layout

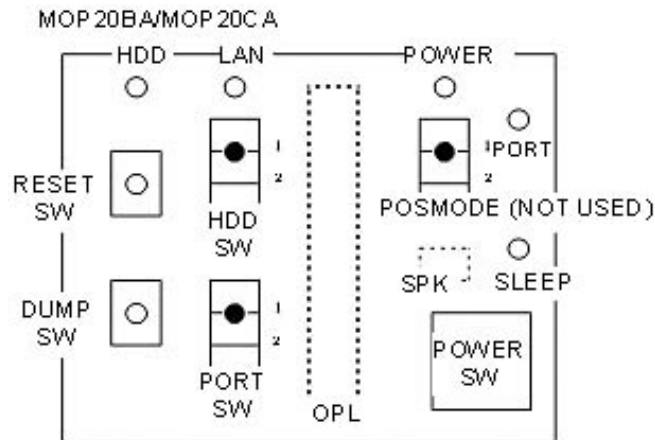

7.10.2 Operator Panel Settings

| No. | Setting Name | Meaning | Default Settings |
|-----|--------------|---|------------------|
| 1 | POSMODE | Not Used | 1 N/A |
| 2 | HDDSW | Setting for activating the HDD 1: HDD0 (Master) 2: HDD1 (Slave) | 1: HDD0 |
| 3 | PORTSW | Setting for supplying power to Retail-I/O 1: Output 2: No output | 1: Output |
| 4 | Reset Switch | Reboots System | |
| 5 | Dump Switch | Dumps/Clears the CMOS on the Retail I/O Board. Warning, hitting the dump switch will cause loss of CMOS applications data. | |

7.11 Memory (DIMM or SDRAM)



Caution: To prevent electric shock, confirm that the AC cable is removed from the AC outlet anytime the covers are removed. Be sure to observe all ESD precautions and power off procedures.

Use this procedure to replace memory or to add memory (upgrade) These instructions refer to the memory as DIMM, but the instructions apply to both DIMM and SDRAM memory. Note that the A and H motherboards have 3 memory slots and the M motherboard has 2 memory slots.

1. Remove the AC power cable.
2. Remove the front cover (see section 5.1.1).
3. Remove the side cover (left) (see section 5.1.2).
4. Pull the main board out completely, and place on flat surface.
5. If memory is being replaced, push both DIMM (or SDRAM) levers at both ends down towards the outside to remove the memory unit from the main board.
6. If memory is being added, push the two levers down out and down as far as they will go

DIMM Slots
(In the picture, DIMM sockets 2 and 3 are empty.
M motherboard has only 2 sockets)



'A' motherboard shown here

7. Insert the DIMM into an empty socket as shown below.

Note: Start adding DIMMs in rear socket and work forward to make future upgrades more convenient.



Caution: Installing memory improperly can damage the memory and/or the PC Board.

When installing memory, ensure that it is inserted properly. DIMMs have two small cutouts on the edge connector that must match the socket.

When inserting DIMMs into the socket, carefully push them down into the socket until the levers lock into place. The locking should be automatic and not require pressure on the levers.

8. After inserting the DIMM, be sure to check that both sides of the DIMM socket levers are locked into place.

Note: If DIMM socket will not lock, the DIMM is not far enough in the socket and must be pressed harder.

9. If this is an upgrade (adding memory), install the upgrade label that comes with the upgrade kit on the side of the unit near the serial number. See section 5.2.1.



7.12 Chassis Fan



Caution: To prevent electric shock, confirm that the AC cable is removed from the AC outlet anytime the covers are removed. Be sure to observe all ESD precautions and power off procedures.

1. Remove the front cover (see section 5.2.1).
2. Remove the side cover (left) (see section 5.2.2).
3. Disconnect the fan cable near the main board.

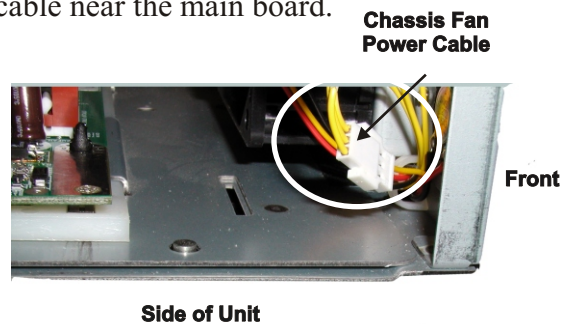

4. Remove two screws (shown in the figure below) from the front of the device, and then lift up on the two top tabs to remove the fan unit.
5. To remount the front fan, reverse the removal procedure.

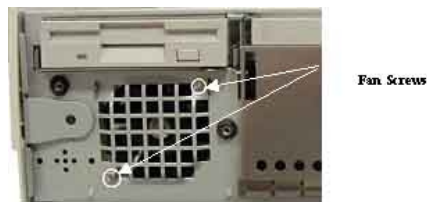

7.13 Retail I/O, TeamCOMBO and TeamUSB Board Replacement

1. Remove the AC power.
2. Remove the front cover (see section 5.1.1).
3. Remove the top cover (see section 5.1.4).
4. Remove the two Philips screws, and then lift Retail I/O, TeamCOMBO or TeamUSB board to remove it from the connector on the riser card. Pull board up until connector on riser is free. More upward pressure is required on the riser card side.

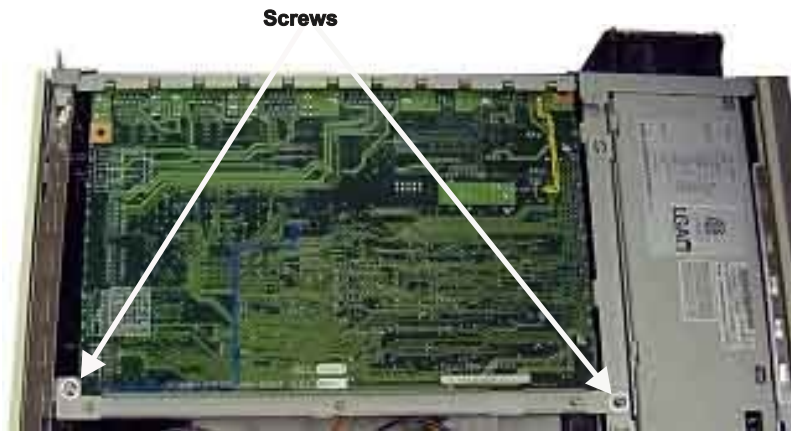

5. To mount the Retail I/O, TeamCOMBO or TeamUSB board again, reverse the removal procedure.
6. When either the TeamCOMBO board or the TeamUSB board is installed, one of the USB ports on the A motherboard becomes unavailable because it is used as a hub for the new I-O board. Install a blanking label, provided with the Upgrade Kit over the top USB port connector on the back of the motherboard.

7.14 Riser Card

Note: Riser cards should be replaced only by the new riser card. Installation process should be the same for both the M and A motherboard.



Caution: To prevent electric shock, confirm that the AC cable is removed from the AC outlet anytime the covers are removed. Be sure to observe all ESD precautions and power off procedures.

1. Remove the AC power cable.
2. Remove the front cover (see section 5.1.1).
3. Remove the side cover (left) (see section 5.1.2).
4. Remove the top cover (see section 5.1.4).
5. Disconnect the power cable from the hard disks, floppy, and media player.
6. Remove the PC board (see section 7.2).
7. Remove the retail I/O board or TeamCOMBO board (see section 7.13).
8. Remove PCI cards (see section 5.1.5).
9. Disconnect the signal cables from hard disk drive(s).
10. Disconnect the cables (four in total) between the riser card, the operation panel, and the power supply unit.





11. Lift the disk cage stabilizer from the top center of the device..
12. Disconnect the signal cables between the riser card, the media player and floppy drives.

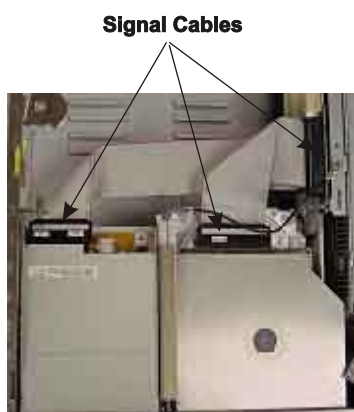

13. Remove the floppy disk drive (see section 7.7), the media player drive (see section 7.8), and hard disk drive(s) (see section 7.6) from the disk cage. Then, completely remove the disk cage from the three holes (shown in the figure below) at the front of the device.



14. Disconnect the hard disk drive signal cable from the riser card.



15. Remove the right and left screws from the top of the riser card.
16. Slide the riser card toward the left of the two tabs on the right side, then lift and remove the card.
17. Disconnect the cables between the riser card and the front fan from the front lower right part of the device. (See diagram section 5.6).
18. To mount the riser card again, reverse the removal procedure.

Note: When mounting the riser card again, lower the card so that it is held between the three rails under the main unit, and then insert the card into the two upper and lower tabs on the front of the main unit.

This page intentionally left blank.

Chapter 8 BIOS Setup Procedures - M Motherboard

Follow the procedures shown below to set the PC board after replacement

8.1 Opening CMOS Setup Screen

Turn ON power and press the DEL key while a "PRESS DEL TO ENTER SETUP" message is displayed in the lower part of the CRT or LCD. (See section 7.1.1 for power on procedures.

A message will appear asking you to enter a password. Hit the "Enter" key and continue

8.1.1 CMOS Settings

In most cases, the CMOS default settings are adequate and do not require changing. Follow the instructions on the screen to select STANDARD CMOS SETUP. To change the time and date follow the instructions on the screen. Run LOAD OPTIMAL DEFAULTS located under the "Exit" tab. Exit, saving settings. Changing other default settings can adversely effect the operation of the unit.

8.1.2 Main Menu - M Motherboard

| BIOS SETUP UTILITY VXX.xx | | | | | | | |
|--|----------|------------------|------|----------|--|-------|---------|
| Main | Advanced | PCIPnP | Boot | Security | Chipset | Power | Other ► |
| System Overview | | | | | Instructions on how to set up this screen will appear in this area. | | |
| AMIBIOS Version : XX.XX.xx Build Date : XX/XX/XX ID : 1AMBCO32* | | | | | | | |
| Processor Type : Intel (R) Pentium (R) M processor Speed : XXXXMHz Count : 1 | | | | | Select Screen Select Item + - Change Field Tab Select Field F1 General Help F10 Save and Exit ESC Exit | | |
| System Memory Size : XXXMB | | | | | | | |
| System Time | | [XX:XX:xx] | | | | | |
| System Date | | [Day XX/XX/XXXX} | | | | | |
| (C) Copyright 1985-2003, American Megatrends, Inc. | | | | | | | |

Note: System memory will always show 32MB less than actually installed since 32MB is reserved for video memory.

* This is a typical entry. The number will change depending on the version of BIOS being used.

8.1.3 Advanced Settings - M Motherboard

| BIOS SETUP UTILITY VXX.xx | | | | | | | |
|---|----------|--------|------|----------|---|-------|---------|
| Main | Advanced | PCIPnP | Boot | Security | Chipset | Power | Other ▶ |
| Advanced Settings | | | | | | | |
| <p>WARNING: Setting wrong values in below sections may cause system to malfunction</p> <ul style="list-style-type: none"> ▶ CPU Configuration ▶ IDE Configuration ▶ Floppy Configuration ▶ SuperIO Configuration ▶ Hardware Health Configuration ▶ ACPI Configuration ▶ DMI Event Logging ▶ Remote Access Configuration ▶ USB Configuration | | | | | <p>Use the right arrow to bring up submenu</p> <p>Instructions will appear in this part of the screen.</p> | | |
| | | | | | <p>Select Screen</p> <p>Select Item</p> <p>+ - Change Field</p> <p>Tab Select Field</p> <p>F1 General Help</p> <p>F10 Save and Exit</p> <p>ESC Exit</p> | | |
| (C) Copyright 1985-2003, American Megatrends, Inc. | | | | | | | |

8.1.4 Configure Advanced CPU Settings - M Motherboard

| BIOS SETUP UTILITY VXX.xx | | | | | | | |
|--|----------|--------|------------|----------|--|-------|---------|
| Main | Advanced | PCIPnP | Boot | Security | Chipset | Power | Other ▶ |
| Configure advanced CPU settings | | | | | <p>Instructions will appear in this part of the screen.</p> <p>Select Screen</p> <p>Select Item</p> <p>+ - Change Field</p> <p>Tab Select Field</p> <p>F1 General Help</p> <p>F10 Save and Exit</p> <p>ESC Exit</p> | | |
| Manufacturer: Intel | | | | | | | |
| CPU Type: Intel (R) Pentium (R) M processor | | | | | | | |
| Frequency : XXX MHz | | | | | | | |
| Cache L1 : XXXKB | | | | | | | |
| Cache L2 : XXXXKB | | | | | | | |
| Cache L3 : 0 KB | | | | | | | |
| Ratio Status : Locked | | | | | | | |
| Ratio Actual Value : XX | | | | | | | |
| Intel (R) SpeedStep (tm) tech. | | | [Disabled] | | | | |
| L2 Cache ECC | | | [Enabled] | | | | |
| (C) Copyright 1985-2003, American Megatrends, Inc. | | | | | | | |

8.1.5 IDE Configuration - M Motherboard

| BIOS SETUP UTILITY VXX.xx | | | |
|--|----------------|--------|---------------|
| Main | Advanced | PCIPnP | Other ▶ |
| IDE Configuration | | | |
| OnBoard PCI IDE Controller | [Both] | | |
| ▶ Primary IDE Master | [Hard Disk] | | |
| ▶ Primary IDE Slave | [Hard Disk] | | |
| ▶ Secondary IDE Master | [ATAPI CDROM] | | |
| ▶ Secondary IDE Slave | [Not Detected] | | |
| Hard Disk Write Protect | [Disabled] | | Select Screen |
| IDE Detect Time Out (Sec) | [35] | | Select Item |
| ATA(PI) 80Pin Cable Detection | [Device] | + - | Change Field |
| | | Tab | Select Field |
| | | F1 | General Help |
| | | F10 | Save and Exit |
| | | ESC | Exit |
| <p>Use the right arrow to bring up Submenu</p> <p>Instructions will appear in this part of the screen.</p> | | | |
| (C) Copyright 1985-2003, American Megatrends, Inc. | | | |

8.1.6 Primary IDE Master - M Motherboard

| BIOS SETUP UTILITY VXX.xx | | | | | | | |
|---|----------|--------|-----------|----------|--|-------|---------------|
| Main | Advanced | PCIPnP | Boot | Security | Chipset | Power | Other ▶ |
| Primary IDE Master | | | | | <p>Instructions will appear in this part of the screen.</p> | | |
| Device : Hard Disk Vendor: : ST310220A Size : XX.xGB LBA Mode : Supported Block Mode:16 Sectors PIO Mode: :4 Async DMA: MultiWord DMA-2 Ultra DMA :Ultra DMA-4 S.M.A.R.T. : Supported | | | | | | | |
| Type | | | [Auto] | | + - | | Change Field |
| LBA/Large Mode | | | [Auto] | | Tab | | Select Field |
| PIO Mode | | | [Auto] | | F1 | | General Help |
| S.M.A.R.T. | | | [Auto] | | F10 | | Save and Exit |
| 32Bid Data Transfer | | | [Enabled] | | ESC | | Exit |
| (C) Copyright 1985-2003, American Megatrends, Inc. | | | | | | | |

Note: If an external USB CDROM drive is connected, it must be selected as the first boot drive in order to boot from it. Refer to 8.1.21 for Boot Group Priority.

8.1.7 Primary IDE Slave - M Motherboard

| BIOS SETUP UTILITY VXX.xx | | | | | | | |
|--|-----------|--------|------|----------|--|-------|----------|
| Main | Advanced | PCIPnP | Boot | Security | Chipset | Power | Other> ▶ |
| Primary IDE Slave | | | | | <p>Instructions will appear in this part of the screen.</p> <p>Select Screen</p> <p>Select Item</p> <p>+ - Change Field</p> <p>Tab Select Field</p> <p>F1 General Help</p> <p>F10 Save and Exit</p> <p>ESC Exit</p> | | |
| Device : Not Detected | | | | | | | |
| Type | [Auto] | | | | | | |
| LBA/Large Mode | [Auto] | | | | | | |
| Block (Multi-Sector Transfer) | [Auto] | | | | | | |
| PIO Mode | [Auto] | | | | | | |
| S.M.A.R.T. | [Auto] | | | | | | |
| 32Bit Data Transfer | [Enabled] | | | | | | |
| (C) Copyright 1985-2003, American Megatrends, Inc. | | | | | | | |

8.1.8 Secondary IDE Master - M Motherboard

| BIOS SETUP UTILITY VXX.xx | | | | | | | |
|---|----------|--------|------|----------|--|-------|---------|
| Main | Advanced | PCIPnP | Boot | Security | Chipset | Power | Other ▶ |
| Secondary IDE Master | | | | | <p>Instructions will appear in this part of the screen.</p> <p>Select Screen</p> <p>Select Item</p> <p>+ - Change Field</p> <p>Tab Select Field</p> <p>F1 General Help</p> <p>F10 Save and Exit</p> <p>ESC Exit</p> | | |
| Device : ATAPI CDROM Vendor: : SD-2245 LBA Mode : Supported PIO Mode :4 Async DMA:MultiWord DMA-2 Ultra DMA :Ultra DMA-2 | | | | | | | |
| Type [Auto] PIO Mode [Auto] DMA Mode [Auto] | | | | | | | |
| (C) Copyright 1985-2003, American Megatrends, Inc. | | | | | | | |

Note: If an external USB CDROM drive is connected, it must be selected as the first boot drive in order to boot from it. Refer to 8.1.21 for Boot Group Priority.

8.1.10 Configure Win627 Super IO Chipset - M Motherboard

| BIOS SETUP UTILITY VXX.xx | | | | | | | |
|--|----------|--------|------------|----------|--|-------|---------|
| Main | Advanced | PCIPnP | Boot | Security | Chipset | Power | Other>▶ |
| Configure Win627 Super IO Chipset | | | | | <p>Instructions will appear in this part of the screen.</p> <p>Select Screen</p> <p>Select Item</p> <p>+ - Change Field</p> <p>Tab Select Field</p> <p>F1 General Help</p> <p>F10 Save and Exit</p> <p>ESC Exit</p> | | |
| OnBoard Floppy Controller | | | [Enabled] | | | | |
| Serial Port1 Address | | | [3F8/IRQ4] | | | | |
| Serial Port2 Address | | | [2F8/IRQ3] | | | | |
| Serial Port2 Mode | | | [Normal] | | | | |
| OnBoard CIR Port | | | [Disabled] | | | | |
| Parallel Port Address | | | [Disabled] | | | | |
| (C) Copyright 1985-2003, American Megatrends, Inc. | | | | | | | |

8.1.11 Hardware Health Configuration - M Motherboard

| BIOS SETUP UTILITY VXX.xx | | | | | | | |
|--|----------|--------|-------------------|----------|--|-------|---------|
| Main | Advanced | PCIPnP | Boot | Security | Chipset | Power | Other ▶ |
| Hardware Health Configuration | | | | | <p>Instructions will appear in this part of the screen.</p> <p>Select Screen</p> <p>Select Item</p> <p>+ - Change Field</p> <p>Tab Select Field</p> <p>F1 General Help</p> <p>F10 Save and Exit</p> <p>ESC Exit</p> | | |
| H/W Alarm/Shutdown Functions | | | [Enabled] | | | | |
| Hardware Health Event Monitoring | | | | | | | |
| CPU Temperature | | | :32°C/69°F | | | | |
| CPU TMP Alarm/Shutdown | | | [Shutdown Enable] | | | | |
| Temperature | | | [85°C/185°F] | | | | |
| System Temperature | | | :25°C/77°F | | | | |
| System TMP Alarm/Shutdown | | | [Shutdown Enable] | | | | |
| Temperature | | | [70°C/158°F] | | | | |
| Low Temperature | | | [Disabled] | | | | |
| Fan1(CPU) Speed | | | :7258 RPM | | | | |
| FAN1 (CPU) Alarm/Shutdown | | | [Disabled] | | | | |
| Fan2 (PSU) Speed | | | :4623 RPM | | | | |
| FAN2 (PSU) Alarm/Shutdown | | | [Disabled] | | | | |
| Fan3 (Enclosure) Speed | | | :4530 RPM | | | | |
| FAN3 (Enclosure) Alarm/Shutdo | | | [Disabled] | | | | |
| (C) Copyright 1985-2003, American Megatrends, Inc. | | | | | | | |

8.1.13 General ACPI Configuration - M Motherboard

| BIOS SETUP UTILITY VXX.xx | | | | | | | |
|--|----------|-----------------|------|----------|---|-------|----------|
| Main | Advanced | PCIPnP | Boot | Security | Chipset | Power | Other> ▶ |
| General ACPI Configuration | | | | | <p>Instructions will appear in this part of the screen</p> <p>Select Screen</p> <p>Select Item</p> <p>+ - Change Field</p> <p>Tab Select Field</p> <p>F1 General Help</p> <p>F10 Save and Exit</p> <p>ESC Exit</p> | | |
| Suspend mode | | [S1 & S3 (STR)] | | | | | |
| (C) Copyright 1985-2003, American Megatrends, Inc. | | | | | | | |

8.1.14 Advanced ACPI Configuration - M Motherboard

| BIOS SETUP UTILITY VXX.xx | | | | | | | |
|--|----------|--------|--------------|----------|---|-------|---------|
| Main | Advanced | PCIPnP | Boot | Security | Chipset | Power | Other ▶ |
| Advanced ACPI Configuration | | | | | <p>Instructions will appear in this part of the screen</p> <p>Select Screen</p> <p>Select Item</p> <p>+ - Change Field</p> <p>Tab Select Field</p> <p>F1 General Help</p> <p>F10 Save and Exit</p> <p>ESC Exit</p> | | |
| ACPI 2.0 Features | | | [Yes] | | | | |
| ACPI APIC Support | | | [Enabled] | | | | |
| AMI OEMB Table | | | [Enabled] | | | | |
| Headless mode | | | [Enabled] | | | | |
| AC Power Recovery | | | [Last State] | | | | |
| (C) Copyright 1985-2003, American Megatrends, Inc. | | | | | | | |

8.1.15 Event Logging Details - M Motherboard

| BIOS SETUP UTILITY VXX.xx | | | | | | | |
|---|----------|--------|------|----------|---|-------|---------|
| Main | Advanced | PCIPnP | Boot | Security | Chipset | Power | Other ▶ |
| Event Logging details | | | | | <p>Instructions will appear in this part of the screen</p> <p>Select Screen</p> <p>Select Item</p> <p>+ - Change Field</p> <p>Tab Select Field</p> <p>F1 General Help</p> <p>F10 Save and Exit</p> <p>ESC Exit</p> | | |
| <p>View Event Log</p> <p>Mark all events as read</p> <p>Clear Event Log</p> <p>Event Log Statistics</p> <p>ECC Event Logging [Enabled]</p> <p>Display read events [Enabled]</p> | | | | | | | |
| (C) Copyright 1985-2003, American Megatrends, Inc. | | | | | | | |

8.1.16 Configure Remote Access Type and Parameters - M Motherboard

| BIOS SETUP UTILITY VXX.xx | | | | | | | |
|--|----------|--------|------------|----------|---|-------|---------|
| Main | Advanced | PCIPnP | Boot | Security | Chipset | Power | Other ▶ |
| Configure Remote Access type and parameters | | | | | | | |
| Remote Access | | | [Disabled] | | | | |
| | | | | | <p>Instructions will appear in this part of the screen</p> | | |
| | | | | | <p>Select Screen</p> <p>Select Item</p> <p>+ - Change Field</p> <p>Tab Select Field</p> <p>F1 General Help</p> <p>F10 Save and Exit</p> <p>ESC Exit</p> | | |
| (C) Copyright 1985-2003, American Megatrends, Inc. | | | | | | | |

8.1.17 USB Configuration - M Motherboard

| BIOS SETUP UTILITY VXX.xx | | | | | | | |
|--|----------|--------|------------|----------|---|-------|---------|
| Main | Advanced | PCIPnP | Boot | Security | Chipset | Power | Other ▶ |
| USB Configurator | | | | | <p>Instructions will appear in this part of the screen</p> <p>Select Screen</p> <p>Select Item</p> <p>+ - Change Field</p> <p>Tab Select Field</p> <p>F1 General Help</p> <p>F10 Save and Exit</p> <p>ESC Exit</p> | | |
| Module Version - X:XX.x-x.x | | | | | | | |
| USB Devices Enabled: None | | | | | | | |
| Legacy USB Support | | | [Enabled] | | | | |
| USB 2.0 Controller Mode | | | [Full] | | | | |
| USB Beep Message | | | [Disabled] | | | | |
| (C) Copyright 1985-2003, American Megatrends, Inc. | | | | | | | |

8.1.18 Advanced PCI/PnP Settings - M Motherboard

| BIOS SETUP UTILITY VXX.xx | | | | | | | | | |
|--|----------|--------|-------------|--|---------------|-------|---------|---------------|--------------|
| Main | Advanced | PCIPnP | Boot | Security | Chipset | Power | Other ► | | |
| Advanced PCI/PnP Settings | | | | | | | | | |
| WARNING: Setting wrong values in below sections may cause system to malfunction | | | | | | | | | |
| Plug & Play O/S | | | [No] | Instructions will appear in this part of the screen | | | | | |
| PCI Latency Timer | | | [64] | | | | | | |
| Allocate IRQ to PCI VGA | | | [No] | | | | | | |
| Palette Snooping | | | [Disabled] | | | | | | |
| PCI IDE BusMaster | | | [Disabled] | | | | | | |
| OffBoard PCI/ISA IDE Card | | | [Auto] | | | | | Select Screen | |
| IRQ3 | | | [Available] | | | | | + - | Select Item |
| IRQ4 | | | [Available] | | | | | Tab | Change Field |
| IRQ5 | | | [Reserved] | | | | | F1 | Select Field |
| IRQ7 | | | [Available] | | | | | F10 | General Help |
| IRQ9 | | | [Available] | ESC | Save and Exit | | | | |
| IRQ10 | | | [Available] | | Exit | | | | |
| IRQ11 | | | [Available] | | | | | | |
| IRQ14 | | | [Available] | | | | | | |
| (C) Copyright 1985-2003, American Megatrends, Inc. | | | | | | | | | |

8.1.19 Boot Settings - M Motherboard

| BIOS SETUP UTILITY VXX.xx | | | | | | | |
|--|----------|--------|------|--|---------|-------|---------|
| Main | Advanced | PCIPnP | Boot | Security | Chipset | Power | Other ▶ |
| Boot Settings | | | | | | | |
| <ul style="list-style-type: none"> ▶ Boot Settings Configuration ▶ Boot Group Priority ▶ Boot Device Priority | | | | <p>Instructions will appear in this part of the screen</p> | | | |
| | | | | <p style="text-align: right;">Select Screen</p> <p style="text-align: right;">Select Item</p> <p style="text-align: right;">+ - Change Field</p> <p style="text-align: right;">Tab Select Field</p> <p style="text-align: right;">F1 General Help</p> <p style="text-align: right;">F10 Save and Exit</p> <p style="text-align: right;">ESC Exit</p> | | | |
| (C) Copyright 1985-2003, American Megatrends, Inc. | | | | | | | |

8.1.20 Boot Settings Configuration - M Motherboard

| BIOS SETUP UTILITY VXX.xx | | | | | | | |
|--|----------|--------------|------|---|---------|-------|---------|
| Main | Advanced | PCIPnP | Boot | Security | Chipset | Power | Other ► |
| Boot Settings Configuration | | | | <p>Instructions will appear in this part of the screen</p> <p>Select Screen</p> <p>Select Item</p> <p>+ - Change Field</p> <p>Tab Select Field</p> <p>F1 General Help</p> <p>F10 Save and Exit</p> <p>ESC Exit</p> | | | |
| Quick Boot | | [Enabled] | | | | | |
| Quiet Boot | | [Disabled] | | | | | |
| AddOn ROM Display Mode | | [Force BIOS] | | | | | |
| Bootup Num-Lock | | [On] | | | | | |
| PS/2 Mouse Support | | [Auto] | | | | | |
| Typematic Rate | | [Fast] | | | | | |
| System Keyboard | | [Present] | | | | | |
| Hit 'DEL' Message Display | | [Enabled] | | | | | |
| Interrupt 19 Capture | | [Disabled] | | | | | |
| LOGO Show | | [Disabled] | | | | | |
| (C) Copyright 1985-2003, American Megatrends, Inc. | | | | | | | |

8.1.22 Boot Device Priority - M Motherboard

| BIOS SETUP UTILITY VXX.xx | | | | | | | |
|---|----------|--------|------|--|---------|-------|---------|
| Main | Advanced | PCIPnP | Boot | Security | Chipset | Power | Other ▶ |
| Boot Device Priority | | | | | | | |
| <ul style="list-style-type: none"> ▶ Hard Disk Drives ▶ Removable Drives ▶ CD ROM Drives | | | | <p>Instructions will appear in this part of the screen</p> | | | |
| | | | | <p style="text-align: right;">Select Screen</p> <p style="text-align: right;">Select Item</p> <p style="text-align: right;">+ - Change Field</p> <p style="text-align: right;">Tab Select Field</p> <p style="text-align: right;">F1 General Help</p> <p style="text-align: right;">F10 Save and Exit</p> <p style="text-align: right;">ESC Exit</p> | | | |
| (C) Copyright 1985-2003, American Megatrends, Inc. | | | | | | | |

8.1.23 Hard Disk Drives - M Motherboard

| BIOS SETUP UTILITY VXX.xx | | | | | | | |
|--|----------|-------------------|------|---|---------|-------|---------|
| Main | Advanced | PCIPnP | Boot | Security | Chipset | Power | Other ► |
| Hard Disk Drives | | | | | | | |
| 1st Drive | | [HDD: ST320014A]* | | | | | |
| | | | | <p>Instructions will appear in this part of the screen</p> <p>Select Screen</p> <p>Select Item</p> <p>+ - Change Field</p> <p>Tab Select Field</p> <p>F1 General Help</p> <p>F10 Save and Exit</p> <p>ESC Exit</p> | | | |
| (C) Copyright 1985-2003, American Megatrends, Inc. | | | | | | | |

Note: If a USB hard disk drive is connected, it must be selected as the first hard drive in order to boot from it.

* This is a typical entry. It will change depending on how the hardware is configured.

8.1.24 Removable Drive - M Motherboard

| BIOS SETUP UTILITY VXX.xx | | | | | | | |
|--|----------|--------------------|------|---|---------|-------|---------|
| Main | Advanced | PCIPnP | Boot | Security | Chipset | Power | Other ► |
| Removable Drives | | | | | | | |
| 1st Drive | | [1st FLOPPY DRIVE] | | <p>Instructions will appear in this part of the screen</p> <p>Select Screen</p> <p>Select Item</p> <p>+ - Change Field</p> <p>Tab Select Field</p> <p>F1 General Help</p> <p>F10 Save and Exit</p> <p>ESC Exit</p> | | | |
| | | | | | | | |
| (C) Copyright 1985-2003, American Megatrends, Inc. | | | | | | | |

Note: If a USB key is connected, it shows up as a second removable device, user will have to select which device should be treated as the 1st drive. See 8.1.21 Booth Group Priority

8.1.25 CD ROM Drives - M Motherboard

| BIOS SETUP UTILITY VXX.xx | | | | | | | |
|--|----------|--------------------|------|---|---------|-------|---------|
| Main | Advanced | PCIPnP | Boot | Security | Chipset | Power | Other ► |
| CDROM Drives | | | | | | | |
| 1st Drive | | [CDROM: SD-R2512]* | | | | | |
| | | | | <p>Instructions will appear in this part of the screen</p> <p>Select Screen</p> <p>Select Item</p> <p>+ - Change Field</p> <p>Tab Select Field</p> <p>F1 General Help</p> <p>F10 Save and Exit</p> <p>ESC Exit</p> | | | |
| (C) Copyright 1985-2003, American Megatrends, Inc. | | | | | | | |

Note: If an external USB CDROM is connected, user will have to select which boot device should be 1st drive. See 8.1.21 Boot Group Priority.

* This is a typical entry. It will change depending on how the hardware is configured.

8.1.28 Configure Advanced Settings for NorthBridge - M Motherboard

| BIOS SETUP UTILITY VXX.xx | | | | | | | |
|--|----------|--------|-----------------|----------|--|-------|---------|
| Main | Advanced | PCIPnP | Boot | Security | Chipset | Power | Other ▶ |
| Configure advanced settings for NorthBridge | | | | | <p>Instructions will appear in this part of the screen</p> <p>Select Screen</p> <p>Select Item</p> <p>+ - Change Field</p> <p>Tab Select Field</p> <p>F1 General Help</p> <p>F10 Save and Exit</p> <p>ESC Exit</p> | | |
| Primary Video Device | | | [Internal] | | | | |
| Graphics Mode Select | | | [Enabled, 32MB] | | | | |
| Memory ECC Mode | | | [Enabled] | | | | |
| IGD - Device 2,Function 1: | | | [Enabled] | | | | |
| Boot Type: | | | [VBIOS Default] | | | | |
| Flat Panel Scaling: | | | [Auto] | | | | |
| Grace Period | | | [Turbo] | | | | |
| GM/GM+ Graphics Frequency | | | [Auto] | | | | |
| (C) Copyright 1985-2003, American Megatrends, Inc. | | | | | | | |

8.1.29 Configure Advanced Settings for SouthBridge - M Motherboard

In the Chipset Southbridge screen, scroll down to see additional settings.

| BIOS SETUP UTILITY VXX.xx | | | | | | | | | |
|--|----------|--------|------------|----------|--|-------|---------|-------------------|--|
| Main | Advanced | PCIPnP | Boot | Security | Chipset | Power | Other ▶ | | |
| Configure advanced settings for SouthBridge | | | | | Instructions will appear in this part of the screen | | | | |
| ICH4 Dev31 Func1, IDE | | | [Enabled] | | | | | | |
| ICH4 Dev31 Func3, SMBUS | | | [Enabled] | | | | | | |
| ICH4 Dev31 Func5, AC'97 | | | [Enabled] | | | | | | |
| ICH4 Dev29 Func0, USB#1 | | | [Enabled] | | | | | | |
| ICH4 Dev29 Func1, USB#2 | | | [Enabled] | | | | | | |
| ICH4 Dev29 Func2, USB#3 | | | [Enabled] | | | | | | |
| ICH4 Dev29 Func7, EHCI | | | [Enabled] | | | | | | |
| Sound Blaster Decode | | | [Disabled] | | | | | Select Screen | |
| Microsoft Sound Decode | | | [Disabled] | | | | | Select Item | |
| MIDI Decode | | | [Disabled] | | | | | + - Change Field | |
| Adlib Range 388h-38Bh | | | [Enabled] | | | | | Tab Select Field | |
| LPC 4Eh-4Fh Decode | | | [Enabled] | | | | | F1 General Help | |
| LPC 2Eh-2Fh Decode | | | [Enabled] | | | | | F10 Save and Exit | |
| Onboard LAN | | | [Enabled] | | | | | ESC Exit | |
| Usage of LAN Option ROM | | | [Enabled] | | | | | | |
| IOAPIC | | | [Disabled] | | | | | | |
| Extended IOAPIC | | | [Disabled] | | | | | | |
| CPU B.I.S.T. | | | [Enabled] | | | | | | |
| ICH4 DMA Collection | | | [Enabled] | | | | | | |
| PC/PCIB Select | | | [Disabled] | | | | | | |
| DMA-0 Type | | | [LPC DMA] | | | | | | |
| DMA-1 Type | | | [LPC DMA] | | | | | | |
| DMA-2 Type | | | [LPC DMA] | | | | | | |
| DMA-3 Type | | | [LPC DMA] | | | | | | |

| BIOS SETUP UTILITY VXX.xx | | | | | | | |
|--|----------|--------|------|---------------------|---------|-------|---------|
| Main | Advanced | PCIPnP | Boot | Security | Chipset | Power | Other ▶ |
| DMA-4 Type | | | | [LPC DMA] | | | |
| DMA-5 Type | | | | [LPC DMA] | | | |
| DMA-6 Type | | | | [LPC DMA] | | | |
| DMA-7 Type | | | | [LPC DMA] | | | |
| On Chip Mac Address | | | | [0010C6209F551] | | | |
| Halt On | | | | [All, But Keyboard] | | | |
| Spread Spectrum | | | | [0.25 Z] | | | |
| Asset NMI on SERR | | | | [Enabled] | | | |
| (C) Copyright 1985-2003, American Megatrends, Inc. | | | | | | | |

Note: User will need to enable wake on LAN, USB, RTC, etc.

8.1.31 Clock Margin - M Motherboard

| BIOS SETUP UTILITY VXX.xx | | | | | | | |
|--|----------|--------|-------------|---|---------|-------|---------|
| Main | Advanced | PCIPnP | Boot | Security | Chipset | Power | Other ► |
| Clock Margin | | | [100] | | | | |
| BIOS Flash | | | | | | | |
| Powered COM1 Config | | | [Disabled] | <p>Instructions will appear in this part of the screen</p> <p>Select Screen</p> <p>Select Item</p> <p>+ - Change Field</p> <p>Tab Select Field</p> <p>F1 General Help</p> <p>F10 Save and Exit</p> <p>ESC Exit</p> | | | |
| Powered COM2 Config | | | [Disabled] | | | | |
| Screen Capture | | | [Enabled] | | | | |
| POST Code | | | [Enabled] | | | | |
| Audio Beep Volume | | | [Max] | | | | |
| FP Speaker | | | [Disabled] | | | | |
| Watch Dog Timer | | | [60 Second] | | | | |
| | | | | | | | |
| (C) Copyright 1985-2003, American Megatrends, Inc. | | | | | | | |

Note: Use right arrow to access "Other" options.

8.1.32 Exit Options - M Motherboard

| BIOS SETUP UTILITY VXX.xx | | | | | | | |
|---|--------|------|----------|---------|--|-------|------|
| ◀ Advanced | PCIPnP | Boot | Security | Chipset | Power | Other | Exit |
| Exit Options | | | | | Instructions will appear in this part of the screen | | |
| Save Changes and Exit Discard Changes and Exit Discard Changes Load Optimal Defaults Save Changes to Floppy Load from Floppy | | | | | | | |
| | | | | | Select Screen Select Item + - Change Field Tab Select Field F1 General Help F10 Save and Exit ESC Exit | | |
| (C) Copyright 1985-2003, American Megatrends, Inc. | | | | | | | |

8.2 BIOS Error Messages - M Motherboard

If BIOS finds an error during a power-ON self-test (POST), an audible beep code is emitted and a message is displayed.

When the message is displayed, the following is also displayed: "PRESS F1 TO CONTINUE, CTRL-ALT-ESC OR DEL TO ENTER SETUP"

If BIOS detects an error during the POST, one or more messages shown below are displayed:

| Error Name | Meaning |
|------------------------------------|--|
| Channel 2 timer error | Error of 8254 Timer |
| CMOS battery failure | CMOS battery test fail |
| CMOS system options net set | T.B.D. |
| CMOS checksum error | CMOS checksum test error |
| Keyboard locked | When key islocking during boot |
| Keyboard not functional | There is no keyboard during boot however in Headless mode it can be bypass |
| Keyboard controller not functional | KB control test fail. |
| CMOS memory size different | When BIOS uses other than "Base Memory: 64KB, Extend memory: 1MB" |
| Memory decreased in size | DIMM Memory size decrease from the previous boot in the system during boot time. |
| Cache Memory Error | |
| Floppy drive 0 error | When Floppy drive is enabled, floppy drive cannot work well. |
| Floppy controller error | Floppy control test fail. |
| CMOS time not set | The time of RTC does not set |
| Number of ATA drive reduced error | Number of ATA Device decrease from the previous boot in the system during boot time. |
| DDC Monitor Configuration Change | System board device resources conflict. |
| 3.3V out of range and the value | +3.3 voltage out of limit |
| +5V out of range and the value | +5 voltage out of limit |
| -5V out of range and the value | -5 voltage out of limit |
| +12V out of range and the value | +12 voltage out of limit |
| -12V out of range and the value | -12 voltage out of limit |

| | |
|---|--|
| +5VSB out of range and the value | +5VSB voltage out of limit |
| Vcore out of range and the value | Vcore voltage out of limit |
| VccP out of range and the value | VccP voltage out of limit |
| System board temperature out of range and the value | System temperature out of limit |
| CPU temperature out of limit | CPU temperature out of limit |
| Fan #1 out of range and the value | FAN#1 speed on [Alarm]/[Shutdown Enabled] is out of limit |
| Fan #2 out of range and the value | FAN#2 speed on [Alarm]/[Shutdown Enabled] is out of limit |
| Fan #3 out of range and the value | FAN#3 speed on [Alarm]/[Shutdown Enabled] is out of limit. |
| Single-bit ECC error | 1 bit ECC error in memory |
| Multi-bit ECC error | 2 bit ECC error in memory |
| Parity memory error | |
| ROM SUM Error | EEPROM checksum error |
| CPU Failure | |

8.3 BIOS Reflash Instructions - M Motherboard

If there are BIOS problems which indicate that the BIOS may be corrupted the BIOS needs to be reflashed.

1. Clear CMOS: This is accomplished by turning off the machine and changing the jumper for BIOS (JP7) from the 1-2 setting (default) to the 2-3 setting. Reboot the machine. When the machine is finished rebooting, shut it off again and reset the jumper to the default setting (1-2).
2. Power on again and press F1 to go into the BIOS.
3. When the password screen appears strike [ENTER] for the User Name and type [MAXPOWER} for the supervisor or administrator name.
4. When the BIOS screen appears, press F10 (Save and Exit). When asked if you want to save the BIOS - press [ENTER].

When reflashing a newer version of BIOS, the passwords will be reset to the above default settings. If a user name or supervisor or administrator password are used they will need to be reset.

This page intentionally left blank.

Chapter 9 BIOS SETUP PROCEDURES - A Motherboard

Follow the procedures shown below to set the PC board after replacement.

9.1 Opening CMOS Setup Screen - A Motherboard

Turn ON power and press the DEL key while a “PRESS DEL TO ENTER SETUP” message is displayed in the lower part of the CRT or LCD. (See section 7.1.1 for power on procedures.)

9.1.1 CMOS Settings - A Motherboard

In most cases, the CMOS default settings are adequate and do not require changing. Follow the instructions on the screen to select STANDARD CMOS SETUP. To change the time and date follow the instructions on the screen. Run LOAD BIOS DEFAULTS first and then LOAD SETUP DEFAULTS. Exit, saving settings. **Changing other default settings can adversely effect the operation of the unit.**

9.1.2 Main Menu - A Motherboard

Factory Default Settings

| ROM PCI/ISA BIOS (XXXXXXXX) | |
|-----------------------------|---------------------------|
| CMOS SETUP UTILITY | |
| AWARD SOFTWARE, INC. | |
| STANDARD CMOS SETUP | CLOCK AND SENSOR |
| BIOS FEATURES SETUP | INTEGRATED PERIPHERALS |
| CHIPSET FEATURES SETUP | SUPERVISOR PASSWORD |
| POWER MANAGEMENT SETUP | USER PASSWORD |
| PNP/PCI CONFIGURAITON | IDE HDD AUTO DETECTION |
| LOAD BIOS DEFAULTS | SAVE & EXIT SETUP |
| LOAD SETUP DEFAULTS | EXIT WITHOUT SAVING |
| ESC : Quit | : Select Item |
| F10 : Save & Exit Setup | (Shift) F2 : Change Color |

9.1.3 Standard CMOS Setup - A Motherboard

Factory Default Settings

| ROM PCI/ISA BIOS (XXXXXXX) | | | | | | | | |
|--|---------------------------|------|-------|--------------------|-----------------|-----------|--------|------|
| STANDARD CMOS SETUP | | | | | | | | |
| AWARD SOFTWARE, INC. | | | | | | | | |
| Date (mm:dd:yy): Sat, Jan 1 2000 | | | | | | | | |
| Time (hh:mm:ss): 0 : 0 : 0 | | | | | | | | |
| HARD DISK | TYPE | SIZE | CYCLS | HEAD | PRECOMP | LANDZ | SECTOR | MODE |
| Primary Master | :Auto | 0M | 0 | 0 | 0 | 0 | 0 | AUTO |
| Primary Slave | :Auto | 0M | 0 | 0 | 0 | 0 | 0 | AUTO |
| Secomdary Master | :Auto | 0M | 0 | 0 | 0 | 0 | 0 | AUTO |
| Secondary Slave | :Auto | 0M | 0 | 0 | 0 | 0 | 0 | AUTO |
| Drive A | : 1.44M, 3.5in. | | | | Base Memory | : 640K | | |
| LCD&CRT | : Both | | | | Extended Memory | : 64512K | | |
| Screen Expansion Mode: | : Disabled | | | | Other Memory | : 384K | | |
| Halt On | : All, But Keyboard | | | | Total Memory | : 65536K* | | |
| Esc: Quit | Select Item | | | PU/PD/+/- : Modify | | | | |
| F1 : Help | (Shift) F2 : Change Color | | | | | | | |
| * Number varies depending on memory installed. | | | | | | | | |

Note: If the controller is configured without a floppy drive, the “A” drive setting will be “None”. Total memory will vary based on configuration.

9.1.4 BIOS Features Setup - A Motherboard

Factory Default Settings

| ROM PCI/ISA BIOS (XXXXXXX) | |
|---|--------------------|
| BIOS FEATURES SETUP | |
| AWARD SOFTWARE, INC. | |
| Virus Warning | : Disabled |
| CPU Internal Cache | : Enabled |
| External Cache | : Enabled |
| CPU L2 Cache EEC Checking | : Enabled |
| Process Number Feature | : Enabled |
| Quick Power On Self Test | : Disabled |
| Boot from LAN First | : Disabled |
| Boot Sequence | : A, C, SCSI |
| Boot Up Floppy Seek | : Enabled |
| Boot Up Numlock Status | : On |
| Gate A20 Option | : Fast |
| Typematic Rate Setting | : Disable |
| Typematic Rate (Chars/Sec) | : 6 |
| Typematic Delay (Msec) | : 250 |
| Security Option | : Setup |
| PCI/VGA Palette Snoop: | : Disabled |
| OS Select for DRAM > 64MB: | : Non-OS2 |
| Report No FDD For WIN 95 | : Yes |
| Full Screen Logo Show* | : Disabled |
| Video BIOS Shadow | : Disabled |
| C8000-CBFFF Shadow | : Disabled |
| CC000-CFFFF Shadow | : Disabled |
| D0000-D3FFF Shadow | : Disabled |
| D4000-D7FFF Shadow | : Disabled |
| D8000-DBFFF Shadow | : Disabled |
| DC000-DFFFF Shadow | : Disabled |
| Esc : Quit | : Select Item |
| F1 : Help | PU/PD/+/- : Modify |
| F5 : Old Values | (Shift) F2 : Color |
| F6 : Load BIOS Defaults | |
| F7 : Load Setup Defaults | |
| * Only found on BIOS level 3.6.3 or later | |

9.1.6 Power Management Setup - A Motherboard

Factory Default Settings

| ROM PCI /ISA BIOS (XXXXXXXX) | | | |
|------------------------------|----------------|---------------------------------|--------------------|
| POWER MANAGEMENT SETUP | | | |
| AWARD SOFTWARE, INC. | | | |
| ACPI Function (see note) | : Disabled | IRQ 8 Break Suspend | : Disabled |
| Power Management | : User Define | ** Reload Global Timer Events** | |
| PM Control by APM | : No | IRQ [3-7, 9-15], NMI | : Disabled |
| Video Off Method | : DPMS | Primary IDE 0 | : Disabled |
| Video Off After | : NA | Primary IDE 1 | : Disabled |
| MODEM Use IRQ | : NA | Secondary IDE 0 | : Disabled |
| Doze Mode | : Disabled | Secondary IDE 1 | : Disabled |
| Standby Mode | : Disabled | Floppy Disk | : Disabled |
| Suspend Mode | : Disabled | Serial Port | : Disabled |
| HDD Power Down | : Disabled | Parallel Port | : Disabled |
| Throttle Duty Cycle | : 50.0% | | |
| PCI/VGA Act-Monitor | : Disabled | | |
| Soft-Off by PWR-BTTN | : Delay 4 sec. | | |
| CPUFAN Off In Suspend | : Disabled | | |
| PowerOn by Ring | : Disabled | | |
| Power On on PCI card | : Disabled | | |
| Resume by alarm | : Disabled | | |
| Wake Up On LAN | : Enabled | | |
| | | Esc: Quit | : Select |
| | | F1 : Help | PU/PD/+/- : Modify |
| | | F5 : Old Valuess | (Shift) F2 : Color |
| | | F6 : Load BIOS Defaults | |
| | | F7 : Load Setup Defaults | |

Note: When a 133PQ keyboard is used in a Windows 2000 or XP environment, ACPI function must be set to "Enabled" or the MSR will not work. If the operating system is configured with ACPI enabled and BIOS is set to ACPI disabled, the system will not boot up.

9.1.7 PNP/PCI Configuration

Factory Default Settings

| ROM PCI/ISA BIOS (XXXXXXX) | | | |
|----------------------------|--------------|--------------------------|-------------------|
| PNP / PCI CONFIGURATION | | | |
| AWARD SOFTWARE, INC. | | | |
| PNP OS Installed | :No | Slot 1 Use IRQ No. | : Auto |
| Resources Controlled by | :Manual | Slot 2 Use IRQ No. | : Auto |
| Reset Configuration Data | :Disabled | Slot 3 Use IRQ No. | : Auto |
| | | Slot 4 Use IRQ No. | : Auto |
| IRQ-3 assigned to | :PCI/ISA PnP | Used MEM base addr | : N/A |
| IRQ-4 assigned to | :PCI/ISA PnP | | |
| IRQ-5 assigned to | :Legacy ISA | | |
| IRQ-7 assigned to | :PCI/ISA PnP | | |
| IRQ-9 assigned to | :PCI/ISA PnP | | |
| IRQ-10 assigned to | :PCI/ISA PnP | | |
| IRQ-11 assigned to | :PCI/ISA PnP | | |
| IRQ-12 assigned to | :PCI/ISA PnP | | |
| IRQ-14 assigned to | :PCI/ISA PnP | | |
| IRQ-15 assigned to | :PCI/ISA PnP | | |
| DMA-0 assigned to | :PCI/ISA PnP | | |
| DMA-1 assigned to | :PCI/ISA PnP | | |
| DMA-3 assigned to | :PCI/ISA PnP | | |
| DMA-5 assigned to | :PCI/ISA PnP | | |
| DMA-6 assigned to | :PCI/ISA PnP | | |
| DMA-7 assigned to | :PCI/ISA PnP | | |
| | | Esc: Quit | Select Item |
| | | F1: Help | PU/PD/+/-: Modify |
| | | F5: Old Values | (Shift) F2: Color |
| | | F6: Load BIOS Defaults | |
| | | F7: Load Set Up Defaults | |

9.1.8 Load BIOS Defaults

This feature should not be used. This feature loads minimum level values as assigned by the BIOS supplier.

9.1.9 Load SETUP Defaults

This feature reloads all Fujitsu defined default values. If run from the main menu, this will reload default values to all sub-menus.

If run from a sub-menu, only the values of that menu will be reloaded.

9.1.10 Clock and Sensor

Factory Default Settings

| ROM PCI/ISA BIOS (XXXXXXXX) | |
|-----------------------------|--------------------|
| CLOCK AND SENSOR | |
| AWARD SOFTWARE, INC. | |
| Auto Detect DIMM/PCI Clk | : Enabled |
| Spread Spectrum | : 0.25% |
| CPU Host CLock (CPU/PCI) | : Default |
| CPU Warning Temperature | : Disabled |
| Current System Temp. | : 28°C/82° F |
| Current CPU1 Temperature | : 38°C/100° F |
| Current CPU FAN1 Speed | : 4017 RPM |
| Current CPU FAN2 Speed | : 4560 RPM |
| Current CPU FAN3 Speed | : 4440 RPM |
| MENDOCINO: | |
| VCore: 2.05V | VTT : 1.55V |
| VCC3 : 3.30V | |
| COPPERMINE: | |
| VCore : 1.60V | VTT : 1.55V |
| VCC3 : 3.30V | |
| +12V : 12.09V | -12V` : -12.11V |
| - 5V : -5.00V | VBAT (V) : 3.24V |
| 5VSB (V) : 5.05V | .5V : 5.00V |
| Shutdown Temperature | : Disabled |
| Esc: Quit | : Select Item |
| F1: Help | PU/PD/+/- : Modify |
| F5 : Old Values | (Shift) F2 : Color |
| F6 : Load BIOS Defaults | |
| F7 : Load Setup Defaults | |

The values should be within the ranges listed below:

Note: The temperature, fan speed, and voltage values are actual dynamic values and will vary. The fan speeds may vary as much as $\pm 10\%$ from the above values. If fan speed drops below 30% of above values, replacement of fan is recommended.

| BIOS Reading | Notes | Low Limit | Typical | High Limit |
|--------------|---|---------------|-------------|---------------|
| Vcore | Celeron, 433 MHz (Mendocino) | 1.85V (-10%) | 2.05V | 2.26V (+10%) |
| | Pentium III & Celeron 566 (Coppermine) See note below | 1.44V (-10%) | 1.61V | 1.76V (+10%) |
| VTT | | 1.50V (-3%) | 1.55V | 1.60V (+3%) |
| VCC3 | | 3.20V (-3%) | 3.3V | 3.39V (+3%) |
| +5V | | 4.80V (-4%)t | 5.0V | 5.20V (+4%) |
| +12V | | 11.52V (-4%) | 12.0V | 12.48V (+4%) |
| -12V | | -12.48V (-4%) | -12.0V | -11.52V (+4%) |
| -5V | | -5.20V (-4%) | -5.0V | -4.80V (+4%) |
| Vbat | Lithium Battery | 2.25V (-25%) | 3.0V | None |
| 5VSB | Stand-By | 4.80V (-4%) | 5.0V | 5.20V (+4%) |
| System Temp | | None | Varies | 60°C |
| CPU 1 Temp | | None | Varies | 60°C |
| CPU 2 Temp | Not Used | None | 0°C | None |
| Fan 1 Speed | CPU Fan | 3150 (-30%) | 4500 RPM | None |
| Fan 2 Speed | PSU Fan | 3150 (-30%) | 4500 RPM | None |
| Fan 3 Speed | Chassis Fan | 3150 (-30%) | 4500 RPM | None |

Note: **Coppermine** is also referred to as 0.18mm technology. The 600MHz, 850MHz and 1 GHz Pentium III and the 566MHz Celeron incorporate Coppermine technology.

9.1.11 Integrated Peripherals

Factory Default Settings

| ROM PCI/ISA BIOS (XXXXXXX) | | | |
|----------------------------|---------|------------|-----------------------|
| INTEGRATED PERIPHERALS | | | |
| AWARD SOFTWARE, INC. | | | |
| IDE HDD Block Mode | : | Enabled | Onboard Parallel Port |
| | | | :378/IRQ7 |
| IDE Primary Master PIO | : | Auto | Parallel Port Mode |
| IDE Primary Slave PIO | : | Auto | : Normal |
| IDE Secondary Master PIO | : | Auto | |
| IDE Secondary Slave PIO | : | Auto | |
| IDE Primary Master UDMA | : | Auto | |
| IDE Primary Slave UDMA | : | Auto | |
| IDE Secondary Master UDMA | : | Auto | |
| IDE Secondary Slave UDMA | : | Auto | |
| On-Chip Primary | PCI IDE | : Enabled | |
| On-Chip Secondary | PCI IDE | : Enabled | |
| USB Keyboard Support | | : Disabled | |
| Onboard PnP Audio Device | | : Enabled | |
| Onboard Lan Chip | | : Enabled | |
| Init Display First | | : PCI Slot | |
| Onboard FDC Controller | | : Enabled | |
| Onboard Serial Port 1 | | : 3F8/IRQ4 | |
| Onboard Serial Port 2 | | : 2F8/IRQ3 | |
| UART2 Mode | | : Standard | |

| | | |
|--|--------------------------|--------------------|
| | Esc : Quit | : Select Item |
| | F1 : Help | PU/PD/+/- : Modify |
| | F5 : Old Values | (Shift) F2: Color |
| | F6 : Load BIOS Defaults | |
| | F7 : Load Setup Defaults | |

9.1.12 Supervisor Password

This feature should not be used. If data is input by mistake, move the JP0701 from pins 1-2 to 2-3 to delete password. See section 7.6.

9.1.13 User Password

This feature should not be used. If data is input by mistake, disconnect the lithium battery and clear the systems CMOS memory.

9.1.14 IDE HDD Auto Detection

This feature should not be used. The installed hard disk(s) are only detected as specified on the standard CMOS set up menu.

9.1.15 Save & Exit SETUP

When the message is displayed asking if changes should be saved, type "Y" and press the "ENTER" key. Any data changed on the sub-menus is written into CMOS memory when the system is rebooted.

9.1.16 Exit Without Saving

When the message is displayed asking if changes should be saved type "N" and press the "ENTER" key. Any changes on the sub-menus are canceled.

9.1.17 BIOS Error Messages

If BIOS finds an error during a power-ON self-test (POST), an audible beep code is emitted or a message is displayed.

When the message is displayed, the following is also displayed: "PRESS F1 TO CONTINUE, CTRL-ALT-ESC OR DEL TO ENTER SETUP"

If BIOS detects an error during the POST, one or more messages as shown below are displayed.

CMOS BATTERY HAS FAILED

CMOS battery is no longer functional. It should be replaced.

CMOS CHECKSUM ERROR

Checksum of CMOS is incorrect. This can indicate that CMOS has become corrupt. A weak battery may have caused this error. Check the battery and replace if necessary.

DISK BOOT FAILURE, INSERT SYSTEM DISK AND PRESS ENTER

No boot device was found. This could mean that either a boot drive was not detected or the drive does not contain proper system boot files. Insert a system disk into Drive A: and press <Enter>. If you assumed the system would boot from the hard drive, make sure the hard drive is inserted correctly and all cables are properly attached. Also be sure the disk is formatted as a boot device and no floppy is inserted. Then reboot the system.

DISKETTE DRIVES OR TYPES MISMATCH ERROR - RUN SETUP

Type of floppy drive installed in the system is different from the CMOS definition. Run Setup to reconfigure the drive type correctly.

ERROR ENCOUNTERED INITIALIZING HARD DRIVE

Hard drive cannot be initialized. Be sure the adapter is installed correctly and all cables are correctly and firmly attached. Also be sure the correct hard drive type or Auto is selected in Setup.

ERROR INITIALIZING HARD DISK CONTROLLER

Cannot initialize controller. Make sure the IDE cable is correctly and firmly installed in the riser slot. Be sure the correct hard disk type or Auto is selected in Setup. Also check to see if any jumper needs to be set correctly on the hard disk.

FLOPPY DISK CNTRLR ERROR OR NO CONTROLLER PRESENT

Cannot find or initialize the floppy drive controller. Make sure the floppy drive cable is seated correctly and firmly. If there is no floppy drive installed, be sure the Floppy Drive selection in Setup is set to NONE.

KEYBOARD ERROR OR NO KEYBOARD PRESENT

Cannot initialize the keyboard. Make sure the keyboard is attached correctly and no keys are being pressed during the boot.

If you are purposely configuring the system without a keyboard, set the error halt condition in Setup to HALT ON ALL, BUT KEYBOARD. This will cause the BIOS to ignore the missing keyboard and continue the boot.

MEMORY ADDRESS ERROR AT...

Indicates a memory address error at a specific location.

MEMORY PARITY ERROR AT...

Indicates a memory parity error at a specific location.

MEMORY VERIFY ERROR AT...

Indicates an error verifying a value already written to memory.

OFFENDING ADDRESS NOT FOUND

This message is used in conjunction with the I/O CHANNEL CHECK and RAM PARITY ERROR messages when the segment that has caused the problem cannot be isolated.

OFFENDING SEGMENT:

This message is used in conjunction with the I/O CHANNEL CHECK and RAM PARITY ERROR messages when the segment that has caused the problem has been isolated.

PRESS A KEY TO REBOOT

This will be displayed at the bottom screen when an error occurs that requires you to reboot. Press any key and the system will reboot.

PRESS F1 TO DISABLE NMI, F2 TO REBOOT

When BIOS detects a Non-Maskable Interrupt condition during boot, this will allow you to disable the NMI and continue to boot, or you can reboot the system with the NMI enabled.

RAM PARITY ERROR - CHECKING FOR SEGMENT

Indicates a parity error in random access memory.

SYSTEM HALTED, (CTRL-ALT-DEL) TO REBOOT

Indicates the present boot attempt has been aborted and the system must be rebooted. Press and hold down the CTRL and ALT keys and press DEL.

FLOPPY DISK (S) fail (80)

Unable to reset floppy subsystem.

FLOPPY DISK (S) fail (40)

Floppy Type mismatches.

Hard Disk(s) fail (80)

HDD reset failed

Hard Disk(s) fail (40)

HDD controller diagnostics failed.

Hard Disk(s) fail (20)

HDD initialization error.

Hard Disk(s) fail (10)

Unable to recalibrate fixed disk.

Hard Disk(s) fail (08)

Sector Verify failed.

BIOS ROM checksum error - System halted.

The checksum of ROM address F0000H-FFFFFFH is bad.

Memory test fail.

If system memory fails, BIOS reports an error.

9.1.18 BIOS Beep Code

The current BIOS has two types of beep codes. The first beep code indicates that an error occurs in the video or BIOS fails in initialization for display. This beep code consists of one long beep signal followed by two short beep signals.

The second beep code indicates that an error occurs in the DRAM (memory) and consists of long repeated beep signals.

This page intentionally left blank.

Chapter 10 SPARE AND UPGRADE PARTS LIST

Parts labeled “Reference only” are not orderable and are listed for reference only.

Part numbers with the extension "K" are Field Upgrade Kits.

| DESCRIPTION | FUJITSU PART | PIN | COMMENTS |
|---|--------------|-----------|--|
| DOCUMENTATION & SOFTWARE | | | |
| DOC TP2K User Guide | 90000290 | 90000290 | |
| DOC TP2K Maintenance Guide | 90000291 | 90000291 | |
| DOCUMENT, MASTER TP2K ITEM LIST | 90000195 | 90000195 | Revision 21.0 (Pentium M Version) |
| CLD, Retail I/O, Version 1.0 | 90000190 | n/a | Only available from the Fujitsu FTP site |
| CLD, TeamCOMBO Board, Version 1.00 | 90000864 | n/a | Only available from the Fujitsu FTP site |
| CONTROLLER PARTS | | | |
| COMPACT CHASSIS W/ACC/USB 2.0 Only | 90000925 | n/a | |
| CONTROLLER, Compact Chassis with USB 2.0 Riser | 90000924 | n/a | Reference only |
| STANDARD CHASSIS W/ACC/USB 2.0 | 90000927 | n/a | |
| CONTROLLER, Standard Chassis with USB 2.0 Riser | 90000926 | n/a | Reference only |
| COMPACT CHASSIS W/ACCESSORIES | 90000262 | n/a | Reference only |
| Compact Chassis | 90000185 | n/a | Reference only |
| STANDARD CHASSIS W/ACCESSORIES | 90000264 | n/a | Reference only |
| Controller, Standard Chassis | 90000215 | n/a | Reference only |
| CHEVRON STD W/ACCESSORY KIT | 90000744 | n/a | Chevron only |
| Standard Chassis FOR CHEVRON ONLY | 90000661 | n/a | Reference only |
| HDD Cable 300mm | CA05951-6401 | n/a | Reference only |
| OPN TP2K Motherboard/S370 | 90000153 | 90000153 | Replaced by 90000459K |
| UPG TP2K Motherboard/S370/R2 | 90000459K | 90000459K | Replaces 90000153 backward compatible, but cannot be replaced by 90000153. |
| HeatSink/Fan, Socket 370 | 90000154 | n/a | Cris to review with GG |

| DESCRIPTION | FUJITSU PART | PIN | COMMENTS |
|--|--------------|-----------|--------------------------|
| HeatSink/Fan, Socket 479 | 90000792 | N/a | Cris to review with GG |
| CBL TP2K Mains/U.S. | 90000255 | 90000255 | |
| CBL TP2K Mains/Europe | 90000256 | 90000256 | |
| CBL TP2K Mains/U.K. | 90000257 | 90000257 | |
| CBL TP2K Mains/Australia | 90000258 | 90000258 | |
| CBL TP2K Mains/South Africa | 90000259 | 90000259 | |
| OPN TP2K CPU/INTEL433 W/FAN/HS | 90000155 | 90000155 | Withdrawn |
| CPU, Intel, Celeron 433, S370 | 90000265 | n/a | Reference only-withdrawn |
| HeatSink/Fan, Socket 370 | 90000154 | n/a | Reference only |
| OPN TP2K CPU/INTEL566 W/FAN/HS | 90000533 | 90000553 | |
| CPU, Intel, Celeron 566, S370 | 90000534 | n/a | Reference only |
| HeatSink/Fan, Socket 370 | 90000154 | n/a | Reference only |
| OPN TP2K CPU/1.3 Celeron M | 90000961 | 90000961 | |
| CPU, Intel, Celeron M, 1.3 GHz, 1.0MB cache, Socket 479, uFCPGA | 90000962 | n/a | Reference only |
| CPU, Intel, Pentium M, 1.5 GHz, Socket 479 | 90000973 | n/a | Reference only |
| CPU, Intel, Pentium M, 1.6 GHz, 1.0MB cache, Socket 479, Ufcpga | 90000833 | n/a | Reference only |
| GASKET, L/W/H=300.0mm/3.3mm/4.8mm | 90001058 | n/a | Reference only |
| GASKET, L/W/H= 80mm/2mm/21mm | 90001059 | n/a | Reference only |
| GASKET, L/W/H= 105mm/2mm/10mm | 90001060 | n/a | Reference only |
| GASKET, L/W/H=20mm/3.5mm/9.5mm | 90001061 | n/a | Reference only |
| GASKET, L/W/H=30mm/3.5mm/9.5mm | 90001062 | n/a | Reference only |
| GASKET, L/W/H=100mm/0.5mm/5mm | 90001063 | n/a | Reference only |
| GASKET, L/W/H=300mm/0.5mm/5mm | 90001064 | n/a | Reference only |
| UPG TP2K 40GB IDE HARD DRIVE | 90000956K | 9000956K | |
| UPG TP2K CBL/Pent M Parallel | 90000865K | 90000865K | |
| UPG TP2K CD-RW/DVD&Software | 90000981K | 90000981K | |
| UPG TP2K CPU/1.5 Pentium-M | 90000972K | 90000972K | |
| CPU, Intel, Pentium M, 1.5 GHz, Socket 479 | 90000973 | 90000973 | Reference only |
| UPG TP2K CPU/1.6 Pentium M | 90000767K | 90000767K | |
| UPG TP2K Disk on Chip/16MB | 90000852K | 90000852K | |

| DESCRIPTION | FUJITSU PART | PIN | COMMENTS |
|---|-----------------------------------|-------------------------|----------------------------------|
| UPG TP2K Memory/DDR/256MB | 90000784K | 90000784K | |
| UPG TP2K Memory/DDR/512MB | 90000785K | 90000785K | |
| UPG TP2K Motherboard/PentM | 90000759K | 90000759K | |
| UPG TP2K TeamUSB I/O Board | 90000803K | 90000803K | |
| UPG TP2K CPU/PIII600 CPU, Intel, PIII 600, S370 Heat Sink/Fan, Socket 370 | 90000156K 90000266 90000154 | 90000156K n/a n/a | Reference only Reference only |
| UPG TP2K CPU/PIII 850 W/FAN/HS CPU, Intel, PIII 850, S370 HeatSink/Fan, Socket 370 | 90000549K 90000564 90000154 | 90000549K n/a n/a | Reference only Reference only |
| UPG TP2K CPU/PIII 1.0 W/FAN/HS CPU, Intel PIII 1.0 GHz, Socket 370 HeatSink/Fan, Socket 370 | 90000706K 90000707 90000154 | 90000706K n/a n/a | Reference only Reference only |
| UPG TP2K DIMM/PC 100/64MB | 90000158K | 90000158K | Withdrawn |
| UPG TP2K DIMM/PC100/128MB | 90000159K | 90000159K | |
| UPG TP2K DIMM/PC100/256MB | 90000160K | 90000160K | |
| OPN TP2K DIMM/PC100/384MB | 90001044 | 90001044 | |
| OPN TP2K Memory/DDR/512MB X 2 | 90000970 | 90000970 | |
| OPN TP2K RETAIL I-O BOARD | 90000161 | 90000161 | |
| UPG TP2K TeamCOMBO Board | 90000273K | 90000273K | Replaced by 90001037 |
| UPG TP2K TeamCOMBO Board/Rev2 | 90001037 | 90001037 | |
| Power Supply Unit with Fan Power Supply Unit | CA05951-2950 CA05951-2951 | n/a n/a | |
| Chassis Fan | CA05950-0263 | n/a | |
| CABLE, Fan Extension, 310mm. | CA05951-3341 | n/a | |
| Operator Panel PWB | CA21258-B80X | n/a | |
| Cable, Operator Panel, 70mm | CA05951-3321 | n/a | |
| Riser Card PCB, 2 PCI | CA21259-B21X | n/a | |
| RISER CARD, 2 PCI Slot | KD20033-B41X | n/a | |
| Lead Acid Battery, w Fuse/Harness | CA05950-0333 | n/a | |
| HDD Cable 190mm | CA05951-6402 | n/a | |
| UPG TP2K 13GB IDE HARD DRIVE | 90000196K | 90000196K | Withdrawn |
| UPG TP 20GB IDE HARD DRIVE | 90000272K | 90000272K | |
| Cable, IDE, HDD, 120mm | CA05951-3301 | n/a | |

| DESCRIPTION | FUJITSU PART | PIN | COMMENTS |
|---|---|--------------------------------|---|
| UPG TP2K CDR/Read Interface CD-ROM/DVD PCB Cable, IDE, CD-ROM/DVD, 110mm Cable, CD ROM/DVD Audio | 90000189K CA21258-B70X CA05951-3291 90000191 | 90000189K n/a n/a n/a | Reference only Reference only Reference only |
| UPG TP2K DVD Interface CD-ROM/DVD PCB Cable, IDE, CD-ROM/DVD 110mm Cable, CD ROM/DVD Audio | 90000165K CA21258-B70X CA05951-3291 90000191 | 90000165K n/a n/a n/a | Replaced by 90000981K Reference only Reference only Reference only |
| UPG TP2K CD-R/CD-RW&Software CABLE, CD ROM RIBBON, LENGTH= 110mm CABLE, CD ROM AUDIO PWA, CD-ROM Connector Board | 90000659K CA05951-3291 90000191 CA21258-B70X | 90000659K n/a n/a n/a | Replaced by 90000981K Reference only Reference only Reference only |
| UPG TP2K FDD/3.5"/1.44 Cable, FDD, 220mm | 90000187K CA05951-3311 | 90000187K n/a | |
| OPN PCIX-690 PCI Video Card | 90000471 | 90000471 | Withdrawn |
| OPN TP2K FRONT DOOR W/LOCK Locking Front Panel Assembly Front Door Lock Assembly | 90000219 CA32154-D003 90000371 | 90000219 n/a n/a | Reference only Reference only |
| OPN TP2K SHORT CONNECTOR COVER | 90000242 | 90000242 | Replaced by CA32154-E106 |
| OPN TP2K Rear Cover/Standard/Short | CA32154-E106 | CA32154-E106 | |
| OPN TP2K Rear Cover/Compact | CA32154-E007 | CA32154-E007 | |
| OPN TP2K Rear Cover/Std/Long | CA32154-E105 | CA32154-E105 | |
| OPN TP2K BRACKET/STD/KYB&CRT Guide, Keyboard Guide, CRT Recessed Flathead Machine Screws, Crossed Head (2 per bracket) | 90000181 CA32154-Y154 80213347 F6-SSA3-05111 | 90000181 n/a n/a n/a | Reference only Reference only Reference only |
| OPN TP2K BRACKET/COM/LCD&KYB Guide, Keyboard Guide, LCD Recessed Flathead Machine Screws, Crossed Head (2 per bracket) | 90000217 CA32154-Y154 CA32154-Y152 F6-SSA3-05111 | 90000217 n/a n/a n/a | Reference only Reference only Reference only |
| OPN TP2K 14" CRT stacking tray 14" CRT Stacking Tray | 80329710 80329711 | PB600307 n/a | Reference only |

| DESCRIPTION | FUJITSU PART | PIN | COMMENTS |
|---|---|-------------------------------|---|
| OPN TP2K BRACKET/STD/FD21 Guide, Printer, FD20/21 Recessed Flathead Machine Screws, Crossed Head (2 perbracket) | 90000214 80213350 F6-SSA3-05111 | 90000214 n/a n/a | Withdrawn Reference only - withdrawn Reference only |
| OPN TP2K Stack HW Axiohm/Ivory | 80602242 | PB600530 | |
| OPN TP2K BRACKET/STD&COM/DT50 Bracket, Metal, DT50/DT50II Printer Recessed Flathead Machine Screws, Crossed Head (2 perbracket) | 90000216 CA32154-Y151 F6-SSA3-05111 | 90000216 n/a n/a | Reference only Reference only |
| OPN TP2K Std. Unit Filler Kit Filler, Plastic Metal Bracket Recessed Flathead Machine Screws, Crossed Head (2 perbracket) | 90000280 CA32154-Y173 CA32154-Y157 F6-SSA3-05111 | 90000280 n/a n/a n/a | Reference only Reference only Reference only |
| Speaker and Cable Assy | CA05950-0329 | n/a | |
| Label, Cable Color Coding, Retail I/O | 90000234 | n/a | Reference only |
| Seal, TeamPoS | 80213743 | n/a | Reference only |
| OPN TP2K I-O BLANK PLATE ONLY | 90000965 | 90000965 | |
| OPN TP2K I-O FILLER KIT | 90000751 | 90000751 | |
| MISC CHASSIS PARTS | | | |
| Front Cover Assy, without Lock, Standard Chassis. For Spares Only. FRONT DOOR, Option, without lock. Used on Compact & Standard Chassis. For Spares Only. | 90000780 90000778 | n/a n/a | Reference only |
| Front Cover Assy, without Lock, Compact Chassis. For Spares Only. FRONT DOOR, Option, without lock. Used on Compact & Standard Chassis. For Spares Only. | 90000781 90000778 | n/a n/a | Reference only |
| Front Cover Assy, with Lock, Standard Chassis. For Spares Only. FRONT DOOR WITH LOCK, OPTION, USED ON COMPACT, STANDARD & CHEVRON STANDARD CHASSIS. | 90000782 90000219 | n/a n/a | Reference only |

| DESCRIPTION | FUJITSU PART | PIN | COMMENTS |
|--|-------------------------|------------|-----------------------|
| Front Cover Assy, with Lock, Compact Chassis. For Spares Only. | 90000783 | n/a | |
| FRONT DOOR WITH LOCK, OPTION, USED ON COMPACT, STANDARD & CHEVRON STANDARD CHASSIS. | 90000219 | n/a | Reference only |
| Top Cover Assembly, Standard | CA32154-E103 | n/a | Replaces CA32154-E003 |
| FRONT COVER SUB-ASSEMBLY, Standard | CA32154-E104 | n/a | |
| File Bay Assy, Compact & Standard | CA32154-E002 | n/a | Reference only |
| Second File Bay Assy, Standard | CA32154-E102 | n/a | Reference only |
| Second File Bay Shield, Standard | CA32154-Y104 | n/a | Reference only |
| Partition Shield, Standard | CA32154-Y197 | n/a | Reference only |
| Speaker Bracket | CA32154-Y053 | n/a | Reference only |
| Cover-Right Assy | CA32154-E005 | n/a | Reference only |
| Cover-Left Assy | CA32154-E006 | n/a | Reference only |
| NLX Lever | CA32154-Y011 | n/a | Reference only |
| Lever Screw | CA32154-Y012 | n/a | Reference only |
| Operator Panel Shield | CA32154-Y035 | n/a | Reference only |
| Riser Insulator Sheet | CA32154-Y096 | n/a | Reference only |
| Rubber Foot | CA31153-Y018 | n/a | Reference only |
| Knurled Screw | CA32154-Y052 | n/a | Reference only |
| Fan Bracket | CA32154-Y055 | n/a | Reference only |
| Switch Cover | CA32154-Y073 | n/a | Reference only |
| Battery Guard | CA32154-Y198 | n/a | Reference only |
| Push Latch | CA82002-1561 | n/a | Reference only |
| 2HDD Shield | CA32154-Y031 | n/a | |
| TP2K 2HDD Shield | CA32154-Y108 | n/a | |
| TP2K FDD Shield | CA32154-Y032 | n/a | |
| TP2K CD ROM Shield | CA32154-Y033 | n/a | |
| KEYBOARDS & CABLES | | | |
| KYB 133UQ PS-2 & USB Int. | 90000598 | 90000598 | |
| OPN 133UQ MSR123 | 90000599 | 90000599 | |
| OPN 133UQ Touch Pad | 90000600 | 90000600 | |
| OPN 133UQ Key-lock/Basic | 90000601 | 90000601 | |
| KYB 133UQ Touch Pad | 90000791 | 90000791 | Replaced by 90000985 |

| DESCRIPTION | FUJITSU PART | PIN | COMMENTS |
|---------------------------------|--------------|--------------|----------------------|
| KYB 133UQ Touch Pad | 90000985 | 90000985 | |
| KYB 133UQ Key-lock #1 | 90000625 | 90000625 | |
| KYB 133UQ MSR 123 | 90000626 | 90000626 | |
| KYB 133UQ Key-lock #1/MSR123 | 90000627 | 90000627 | |
| KYB 133UQ MSR123/Touch Pad | 90000628 | 90000628 | |
| KYB 133UQ MSR123/TP/Lock #1 | 90000629 | 90000629 | |
| CBL 133UQ USB/Stacked/1.20M | 90000602 | 90000602 | |
| CBL 133UQ USB/Dispersed/3.0M | 90000603 | 90000603 | Replaced by 90000849 |
| CBL 133UQ USB/Dispersed/3.5M | 90000849 | 90000849 | |
| CBL 133UQ PS-2/TP/Stacked/1.20M | 90000650 | 90000650 | |
| CBL 133UQ PS-2/TP/DISP/2.0M | 90000651 | 90000651 | |
| OPN 133UQ Blank Tiles/Gray/100 | 90000731 | 90000731 | |
| OPN 133UQ Keycap-lens/1X1/100 | 90000732 | 90000732 | |
| OPN 133UQ Keycap-lens/1X2/50 | 90000733 | 90000733 | |
| OPN 133UQ Keycap-lens/2X2/25 | 90000734 | 90000734 | |
| KYB 133PQ PoS/PC/AT Int | 80328215 | PB600335 | |
| OPN 133PQ KYB MSR/1-2 Kit | 80303315 | 50975/001 | |
| OPN 133PQ KYB MSR 2-3 Kit | 80303316 | 58751/001 | Withdrawn |
| OPN 133PQ KYB/Lock/#2 | 80303319 | 57631/001 | Withdrawn |
| OPN 133PQ KYB/Lock/#3 | 80303320 | 57631/002 | Withdrawn |
| OPN 133PQ KYB/Lock/#4 | 80303321 | 57631/003 | Withdrawn |
| OPN 133PQ KYB/Lock/#5 | 80303322 | 57631/004 | Withdrawn |
| KYB 104P POS/SF | 90000175 | 90000175 | |
| OPN 104P 1X1 KEYCAPS/10 | 90000176 | 90000176 | |
| OPN 104P 1X2 KEYCAPS/10 | 90000177 | 90000177 | |
| OPN 104P 2X2 KEYCAPS/10 | 90000178 | 90000178 | |
| OPN 104P MSR/Track 1-2-3 | CA05951-2356 | CA05951-2356 | |
| CBL 133PQ KYBD/STK/1.20M | 90000163 | 90000163 | |
| CBL 133PQ KYB/DIST/2.0M | 80213559 | 58159/001 | |
| OPN 133PQ KYB, 1X1 Keycaps/100 | 80303337 | 56790/001 | |
| OPN 133PQ KYB, 1X2 Keycaps/ 25 | 80303338 | 59253/001 | |
| OPN 133PQ KYB Blank Tiles | 80303481 | 54004/001 | |
| OPN KYB, 2X2 Keycaps/25 | 80303482 | 53147/001 | |
| OPN 133PQ KYB Key Puller | 80303517 | 56079/001 | Withdrawn |

| DESCRIPTION | FUJITSU PART | PIN | COMMENTS |
|--------------------------------|--------------|-------------|-----------------|
| UPG 133PQ KYB CTR BRD WIN NT | 80602026 | PB600491 | Withdrawn |
| OPN 104P Keyboard Lock #2 | 80329784 | PB600277 | Withdrawn |
| OPN 104P Keyboard Lock #3 | 80329785 | PB600278 | Withdrawn |
| OPN 104P Keyboard Lock #4 | 80329786 | PB600279 | Withdrawn |
| OPN 104P Keyboard/OP Key | 80329845 | PB600323 | Consumable only |
| OPN 104P Keyboard/MGR1 Key | 80329846 | PB600324 | Consumable only |
| OPN 104P Keyboard/MGR2 Key | 80329847 | PB600325 | Consumable only |
| OPN 133PQ KYB KEYCAP LENS/1X1 | 90000356 | 90000356 | |
| OPN 133PQ KYB KEYCAP LENS/1X2 | 90000357 | 90000357 | |
| OPN 133PQ KYB KEYCAP LENS/2X2 | 90000358 | 90000358 | |
| KYB 92U RS232 & USB | 90000630 | 90000630 | |
| KYB 92M RS232 | 53876/001M | 53876/001M | |
| KYB 92M MSR 1-2 | 53876/002M | 53876/002M | |
| KYB 92M MSR 2-3 | 53876/003M | 53876/003M | Withdrawn |
| KYB 92M VFD | 53876/004EM | 53876/004EM | |
| KYB 92M MSR1-2/VFD | 53876/005EM | 53876/005EM | |
| KYB 92M MSR2-3/VFD | 53876/006EM | 53876/006EM | Withdrawn |
| KYB 92M VERT LK | 53876/007M | 53876/007M | Withdrawn |
| KYB 92M V LK/MSR1-2 | 53876/008M | 53876/008M | Withdrawn |
| KYB 92M V LK/MSR2-3 | 53876/009M | 53876/009M | Withdrawn |
| KYB 92M V LK/VFD | 53876/010EM | 53876/010EM | Withdrawn |
| KYB 92M V LK/MSR1-2/VFD | 53876/011EM | 53876/011EM | Withdrawn |
| KYB 92M V LK/MSR2-3/VFD | 53876/012EM | 53876/012EM | Withdrawn |
| VERTICAL KEYLOCK FOR/150 | 80192471 | 52999/001 | |
| CBL 92M STACKED/0.6M | 80203320 | 50275/001 | |
| CBL 92M DISTRIBUTED/3.0M | 80203321 | 50275/002 | |
| CBL 92M DISTRIBUTED/5.0M | 80203322 | 50275/003 | |
| CBL 92U USB/DISTRIBUTED/3.8M | 90000635 | 90000635 | |
| CBL 92U USB/STACKED/0.6M | 90000634 | 90000634 | |
| OPN 92U Vertical Keylock | 90001070 | 90001070 | |
| OPN 92U MSR123 | 90000631 | 90000631 | |
| OPN 92U VFD | 90000632 | 90000632 | |
| OPN 92U BLANK TILES/FJ WHT/100 | 90001074 | 90001074 | |
| OPN 92U KEYCAP-LENS/1X1/100 | 90001075 | 90001075 | |

| DESCRIPTION | FUJITSU PART | PIN | COMMENTS |
|---|--------------|------------|----------------------|
| OPN 92U KEYCAP-LENS/1X2/50 | 90001076 | 90001076 | |
| OPN 92U KEYCAP-LENS/2X2/25 | 90001077 | 90001077 | |
| OPN 92M 1x1 BLANK TILE KIT/100 | 14125/001M | 14125/001M | |
| OPN 92M 1X1 KEYCAP KIT/100 | 14125/002M | 14125/002M | |
| OPN 92M 1X2 KEYCAP KIT/50 | 14125/003M | 14125/003M | |
| OPN 92M 2X2 KEYCAP KIT/25 | 14125/006M | 14125/006M | |
| OPN 92M KEYCAP PULLER KIT/10 | 14125/008M | 14125/008M | Withdrawn |
| DISPLAYS & DISPLAY ACCESSORIES | | | |
| DSP D15 LCD/15"/No Stand | 90000820 | 90000820 | |
| DSP D15 LCD/15"/RTCH/No stand | 90000821 | 90000821 | Replaced by 90001127 |
| DSP D15 LCD/15"/RTCH/No stand | 90001127 | 90001127 | Replaces 90000821 |
| DSP D15 LCD/15"/CTCH/No stand | 90000855 | 90000855 | |
| OPN D15 Keypad/5X8/No Lock | 90001027 | 90001027 | |
| OPN D15 Kit/KYB/MSR/No Lock | 90001028 | 90001028 | |
| KIT, Stacked Stand, Model D15LCD | 90000822 | n/a | Reference only |
| OPN D15 Stand/TP2K/Stacked | 90001067 | 90001067 | |
| OPN D15 Stand/Dispersed | 90000823 | 90000823 | |
| OPN D15 Kit/Stack/VF50 DSP | 90000824 | 90000824 | |
| OPN D15 Kit/DISP/VF50 DSP | 90000825 | 90000825 | |
| OPN D15 LCD Power Supply | 90000829 | 90000829 | |
| OPN D15 Kit/KYB/MSR/Key Lock | 90000830 | 90000830 | |
| OPN D15 MSR Only Kit/3-Track | 90000831 | 90000831 | |
| OPN D15 Keypad/5x8 Matrix/Lock | 90000856 | 90000856 | |
| OPN D15 Kit/In-Counter Mount | 90000858 | 90000858 | |
| CBL D15 Stacked/DVI/.65M | 90000826 | 90000826 | |
| CBL D15 DVI/Dispersed/2.0M | 90000827 | 90000827 | |
| CBL D15 DVI/Dispersed/3.8M | 90000828 | 90000828 | |
| CBL D15 Analog Data/0.65M | 90001046 | 90001046 | |
| CBL D15 Analog Data/2.0M | 90001047 | 90001047 | |
| CBL D15 Analog Data/5.0M | 90001048 | 90001048 | |
| CBL D15 PWR/USB/STACKED/0.65M | 90000835 | 90000835 | |
| CBL D15 PWR/USB/DISPERSED/2.0M | 90000836 | 90000836 | |
| CBL D15 PWR/USB/DISPERSED/3.8M | 90000837 | 90000837 | |
| CBL D15 Mains/IEC 320/M to F | 90001066 | 90001066 | |

| DESCRIPTION | FUJITSU PART | PIN | COMMENTS |
|---|--|---------------------------------|----------------------------------|
| CBL TP2K USB/A to A/0.65M | 90000992 | 90000992 | |
| CBL TP2K USB/A to A/2.0M | 90000993 | 90000993 | |
| CBL TP2K USB/A to A/3.8M | 90000994 | 90000994 | |
| DSP D12D LCD/12.1"/DSTN | 90000166 | 90000166 | Withdrawn |
| DSP D12DT LCD/12.1"/DSTN/TCH | 90000167 | 90000167 | Withdrawn |
| DSP D12T LCD/12.1"/TFT | 90000168 | 90000168 | |
| DSP D12TT LCD/12.1"/TFT/TCH | 90000169 | 90000169 | |
| DSP A12 LCD/12.1"/TFT/AI | 90000361 | 90000361 | Replaced by 90000580 |
| DSP A12 LCD/12.1"/TFT/TCH/AI | 90000362 | 90000362 | Replaced by 90000581 |
| DSP A12 LCD/12/1/TFT/AI | 90000580 | 90000580 | |
| DSP A12 LCD/12/1/TFT/TCH/AI | 90000581 | 90000581 | |
| OPN D12 KYB & MSR KIT for LCD OPN D12 KYB & MSR for LCD Kiosk Keypad w/MSR mounting hardware kit for D12/A12 | 90000354 CA05951-4992 CA32154-D652 | 90000354 CA05951-4992 N/a | Reference only Reference only |
| OPN D12 MSR KIT for LCD OPN D12 MSR for LCD Kiosk MSR mounting hardware kit for D12/A12 | 90000355 CA05951-4990 CA32154-D651 | 90000355 CA05951-4990 n/a | Reference only Reference only |
| CBL D12 LCD KYB/0.8M | 90000363 | 90000363 | |
| CBL D12 LCD KYB/2.0M | 90000364 | 90000364 | |
| CBL D12 LCD KYB/5.0M | 90000365 | 90000365 | |
| CBL D12/A12 PWR Dual LCD/2.0M | CA05951-6061 | CA05951-6061 | |
| CBL D12/A12 PWR Dual LCD/5.0M | CA05951-6062 | CA05951-6062 | |
| CBL A12 Analog Data/0.65M | CA05951-5021 | CA05951-5021 | A12 only |
| CBL A12 Analog Data/2.0M | CA05951-5022 | CA05951-5022 | A12 only |
| CBL A12 Analog Data/5.0M | CA05951-5023 | CA05951-5023 | A12 only |
| CBL D12 Stacked/.65M | CA05951-3101 | CA05951-3101 | |
| CBL D12 Dispersed/2.0M | CA05951-3102 | CA05951-3102 | |
| CBL D12 Dispersed/5.0M | CA05951-3103 | CA05951-3103 | |
| CBL D12 PWR Stacked/.65M | CA05951-3111 | CA05951-3111 | |
| CBL D12 PWR Dispersed/2.0M | CA05951-3112 | CA05951-3112 | |
| CBL D12 PWR Dispersed/5.0M | CA05951-3113 | CA05951-3113 | |
| CBL D12 TCH Screen/Stked/.65M | CA05951-3121 | CA05951-3121 | |

| DESCRIPTION | FUJITSU PART | PIN | COMMENTS |
|--------------------------------|--------------|--------------|----------------------|
| CBL D12 TCH Screen/Disp/2.0M | CA05951-3122 | CA05951-3122 | |
| CBL D12 TCH Screen/Disp/5.0M | CA05951-3123 | CA05951-3123 | |
| CBL D12 Audio/Stacked/.65M | CA05951-3131 | CA05951-3131 | |
| CBL D12 Audio/Dispersed/2.0M | CA05951-3132 | CA05951-3132 | |
| CBL D12 Audio/Dispersed/5.0M | CA05951-3133 | CA05951-3133 | |
| OPN D12 BASE/LCD W-KYB & MSR | 90000452 | 90000452 | |
| OPN D12 BASE/SINGLE LCD | 90000162 | 90000162 | |
| OPN L12T PLATE/VESA | 90000271 | 90000271 | |
| OPN D12 Dual Stack Stand | 90000366 | 90000366 | |
| OPN A/D12 BASE/LCD Only | 90000552 | 90000552 | |
| OPN A12 LCD Power Supply | 90000582 | 90000582 | |
| OPN D12 SPEAKERS | 90000170 | 90000170 | |
| OPN D12 BASE/KIOSK LCD | 90000171 | 90000171 | Replaced by 90000552 |
| OPN TPoS W&M CRT Label/29.99lb | 80328102 | PB600029 | |
| OPN TP W&M CRT LABEL/30.0 LBS | 80602356 | PB600558 | |
| GVISION 15" LCD | L5EX-TA | L5EX-TA | |
| DSP 14"CRT/Color/SVGA | n/a | 068925-000 | |
| DSP C90M CRT/9"/Mono/Stack | 80215699 | 58312/001 | |
| DSP C90MD CRT/9"/Mono/Disp | 80215700 | PB000009 | |
| DSP C90C CRT/9"/Color/ Stack | 80602100 | PB600440 | Withdrawn |
| DSP C90CD CRT/9"/color/Disp | 80602101 | PB600441 | Withdrawn |
| DSP VF50U RS232 & USB Int | KD02902-0171 | KD02902-0171 | |
| DSP VF50 2X20/VFD | CA05951-2921 | CA05951-2921 | |
| DSP VF50 MOUNT KIT, OPERATOR | 80303312 | 51929/001 | Withdrawn |
| DSP VF50 MOUNT KIT/INT/CUST | 80303313 | 58918/001 | |
| TP5000 2x20 DISPLAY W/EURO | 51704/001E | 51704/001E | Withdrawn |
| CBL VF50U USB Int./0.85M | 90000618 | 90000618 | |
| CBL VF50U USB Int./1.5M | 90000619 | 90000619 | |
| CBL VF50U USB Int./3.8M | 90000620 | 90000620 | |
| CBL TP2K VF50 DSP/DIS/5.0M | 80303324 | 50778/001 | |
| CBL TP2K VF50 DSP/INT/0.85M | 80303323 | 51065/001 | |
| CBL TP2K VF50 DSP/1.5M | 80329768 | PB600317 | |
| OPN VF50 MOUNT KIT/INTEG/LONG | CA32154-D711 | CA32154-D711 | |

| DESCRIPTION | FUJITSU PART | PIN | COMMENTS |
|---|--------------|--------------|-----------|
| OPN VF50 MOUNT KIT/INTEG/SHORT | CA32154-D712 | CA32154-D712 | |
| OPN VF50 POLE BASE | 90000211 | 90000211 | |
| OPN VF50 Pole Kit/0.15M | PB501001 | PB501001 | |
| OPN VF50 Pole Kit/0.3M | 80303786 | PB501002 | |
| OPN VF50 Pole Kit/0.6M | 80303787 | PB501003 | |
| DSP 92R 2X20/VFD/EURO | 58967/002E | 58967/002E | |
| CASH DRAWERS & CASH DRAWER ACCESSORIES | | | |
| CDR MP5 STACKED/LOCK#2/SF | CA82003-5002 | CA82003-5002 | |
| CDR MP5 STACKED/LOCK#3/SF | CA82003-5003 | CA82003-5003 | Withdrawn |
| OPN MP5 Media Tray/Int | 80329774 | PB600267 | |
| OPN MP5 Locking CDR Cover | 80329840 | PB600372 | |
| OPN MP5 Cash drawer Lock #2 | 80329787 | PB600280 | Withdrawn |
| OPN MP5 Cash drawer Lock #3 | 80329788 | PB600281 | Withdrawn |
| OPN MP5 Cash drawer Lock #4 | 80329789 | PB600282 | Withdrawn |
| CBL TP10 Dual CDR/TP2K | 80602014 | PB600379 | |
| CBL TP10 CDR/TP2K/Int/0.22M | 80329852 | PB600331 | |
| CBL TP10 CD to DT50/2.0M | 90001055 | 90001055 | |
| CBL TP10 CDR/TP2K/Dis/5.0M | 80329853 | PB600332 | |
| CBL TP10 2nd CDR Ext/TP2K/ 4.0M | 80155637 | 15016/002 | |
| CBL TP10 CD to DT50/5.0M | 90000647 | 90000647 | |
| CBL TP10 CD to DT50/0.5M | 90000652 | 90000652 | |
| OPN TP10 MEDIA Tray | 80303328 | 53140/001 | |
| OPN TP10 CDR 6 COIN TRAY | 80303329 | 50404/001 | |
| OPN TP10 CDR 8 COIN Tray | 80303330 | 58523/001 | |
| OPN TP10 CDR LOCK COVER | 80303331 | 53612/001 | |
| CDR TP10 CD, NO L | 80213376 | 54258/001 | |
| CDR TP10 CD, Lock #1 | 80213377 | 54258/002 | |
| CDR TP10 Lock #2 | 80213378 | 54258/003 | |
| CDR TP10 Lock #3 | 80215557 | PB600014 | |
| CBL ADS CDR/TP2K | 80303335 | 55598/001 | Withdrawn |
| CBL NAF CDR/TP2K/0.5M | 80316677 | PB501005 | Withdrawn |
| CBL NAF CDR/TP2K/4.0M | 80316678 | PB501006 | Withdrawn |
| CDR NF5 No Lock | 90000576 | 90000576 | |

| DESCRIPTION | FUJITSU PART | PIN | COMMENTS |
|---|---------------------|------------|---------------------------------|
| CDR NF5 Lock #1 | 90000577 | 90000577 | |
| OPN NAF Till Tray | n/a | 17083/001 | |
| PRINTERS & PRINTER ACCESSORIES | | | |
| PTR DT50 RECEIPT/SLIP/MICR/3PH | 90000048 | 90000048 | Replaced by 90000543 & 90000773 |
| PTR DT50 RECEIPT/SLIP | 90000056 | 90000056 | Replaced by 90000543 & 90000772 |
| PTR DT50 RECEIPT/SLIP/MICR | 90000057 | 90000057 | Replaced by 90000543 & 90000773 |
| PTR DT50II R/S/No Int. | 90000541 | 90000541 | Replaced by 90000772 |
| PTR DT50II R/S/MICR/3PH/No Int | 90000542 | 90000542 | Replaced by 90000773 |
| PTR DT50II R/S/No Int. | 90000772 | 90000772 | |
| PTR DT50II R/S/M/C/U-TS/NoInt | 90000773 | 90000773 | |
| PTR DT50IIT R/S/M/C/TSCN/NoInt | 90000838 | 90000838 | |
| OPN DT50IIT USB Interface | 90000851 | 90000851 | |
| OPN DT50II RS232 Interface | 90000543 | 90000543 | |
| OPN DT50II USB Interface | 90000544 | 90000544 | |
| CBL TP2K Epson-Axiohm PTR/0.5M | 80602313 | PB600509 | |
| CBL TP2K Epson-Axiohm PTR/3.0M | 80602353 | PB600562 | |
| CBL TP2K Epson-Axiohm PTR/5.0M | 80602314 | PB600510 | |
| CBL EPSON USB/24VDC-PWR/0.65M | 90000698 | 90000698 | |
| CBL EPSON USB/24VDC-PWR/3.0M | 90000699 | 90000699 | Replaced by 90000850 |
| CBL EPSON USB/24VDC-PWR/3.8M | 90000850 | 90000850 | |
| CBL EPSON USB/24VDC-PWR/5.0M | 90000700 | 90000700 | Replaced by 90000850 |
| PTR TM-H5200/MICR/EPSON COLOR | 90000186 | 90000186 | |
| PTR TM-T90 THERMAL 2-COLOR | 90000492 | 90000492 | |
| PTR TM-T88III W/RS232 INT | 90000658 | 90000658 | Replaced by 90000863 |
| PTR TM-T88III W/RS232 INT FJC | 90000863 | 90000863 | |
| PTR Epson TM950 Serial w/Omicr | 80328114 | PB600112 | Withdrawn |
| PTR TM-U925 MICR/Epson | 80328032 | PB600117 | Withdrawn |
| PTR TM-H5000II EPSON/IVORY | 80602341 | PB600525 | |
| OPN TP2K Stack HW Epson/Ivory | 80602241 | PB600527 | Withdrawn |
| PTR A758, FJ-ICL COLOR | 80602362 | PB600553 | Withdrawn |

| DESCRIPTION | FUJITSU PART | PIN | COMMENTS |
|----------------------------------|-------------------------|------------|----------------------|
| PTR A758/MICR, FJ-ICL COLOR | 80602363 | PB600554 | Withdrawn |
| PTR A758/CKFLP, FJ-ICL COLOR | 80602364 | PB600555 | Withdrawn |
| PTR A758/MICR/CKFLP,FJ-ICL CLR | 80602365 | PB600556 | Withdrawn |
| PTR A794/CUTTER, FJ-ICL COLOR | 80602366 | PB600557 | Withdrawn |
| PTR A760 R/S/MICR/ESTBL/FJCLR | 90000697 | 90000697 | |
| PTR A760 RS/MICR/CKFL/ESTBL/FJ | 90000755 | 90000755 | |
| PSU TM-H6000 | 90000042 | 90000042 | Replaced by 90000664 |
| POWER SUPPLY 180 W/POWER CORD | 90000664 | 90000664 | |
| CBL TP2K FD20/21/RS232/0.5M | 80303325 | 51380/001 | |
| CBL TP2K FD20/21/RS232/5.0M | 80303326 | 55222/001 | Withdrawn |



