



Installation & Maintenance Manual

TeamPoS 3000 XT



*Team***PoS** 3000 XT[®]
Installation and Maintenance
Manual

This page intentionally left blank

Fujitsu Transaction Solutions Inc. tries to be sure that the information in this document is correct; however, the company does not accept liability for any errors or omissions.

Fujitsu products and services are continually developed, enhanced, and improved, and published information such as this manual may not be up to date. If you note a problem, please check with Fujitsu Transaction Solutions Inc for the latest status. This document is not part of a contract or license unless expressly agreed.

This document is the first issue.

Regulatory Information

EMC

Radio Frequency Interference Requirements – U.S.A.

This equipment has been tested and found to comply with the limits for a Class A digital device pursuant to Part 15 of the FCC Rules. These limits are designed to provide reasonable protection against harmful interference when the equipment is operated in a commercial environment. This equipment generates, uses, and can radiate radio frequency energy and, if not installed and used in accordance with the instruction manual, may cause harmful interference to radio communications. Operation of this equipment in a residential area is likely to cause harmful interference in which case the user will be required to correct the interference at his own expense.

Radio Frequency Interference Requirements – Canada

This Class A digital apparatus meets all the requirements of the Canadian Interference-Causing Equipment Regulations.

Cet appareil numérique de la classe A respecte toutes les exigences du Règlement sur le matériel brouilleur du Canada.

Radio Frequency Interference Requirements – Europe

This apparatus has been tested and found to comply with the limits for a Class A digital device, per EN55022, for use in Information Technology equipment. In a domestic environment this product may cause radio interference in which case the user may be required to take adequate measures. This apparatus also meets the susceptibility requirements per EN55024. Overall the product qualifies for and bears the CE mark.

Safety

Hazardous Voltage



Warning: Disconnect supply before servicing.

Advertissement: Couper le courant avant l'entretien.



Caution: It is assumed that the user of this manual fully understands and strictly adheres to proper Electrostatic Discharge (ESD) precautions. Failure to adhere to precautions can cause damage to this equipment.

Always remove the power cord from the unit prior to performing any controller maintenance.

 <small>FUJITSU TRANSACTION SOLUTIONS INC.</small> <small>MADE IN USA</small>	<small>ISSUE</small> MODEL 3000K-12 <small>A 0123456789</small> <small>B 0123456789</small>	V= 100-240 ~ S/N: U9XXXXX	A= 3.6A []	Hz= 50/60	 <small>LISTED</small> <small>ITE E301248</small> <small>NTEP CC: 95-083</small>			
	<small>MADE IN USA</small>	[]	[]	[]	[]	[]	[]	[]

 <small>FUJITSU TRANSACTION SOLUTIONS INC.</small> <small>MADE IN USA</small>	<small>ISSUE</small> MODEL 3000K-15 <small>A 0123456789</small> <small>B 0123456789</small>	V= 100-240 ~ S/N: U7XXXXX	A= 3.6A []	Hz= 50/60	 <small>LISTED</small> <small>ITE E301248</small> <small>NTEP CC: 95-083</small>			
	<small>MADE IN USA</small>	[]	[]	[]	[]	[]	[]	[]

Recycling



WARNING: The LCDs used with this product may contain a backlight that contains mercury. Please dispose of according to local, state, or federal laws.

LAMP(S) INSIDE THIS PRODUCT CONTAIN MERCURY AND MUST BE RECYCLED OR DISPOSED OF ACCORDING TO LOCAL, STATE, OR FEDERAL LAWS.

Table of Contents

Chapter 1 - Overview.....	1-1
1.1. Side Panel LEDs and Switch	1-3
1.2. Intelligent PINs (Product Identification Numbers).....	1-5
Chapter 2 - Specifications	2-1
Chapter 3 - Dimensions	3-1
3.1. Displays.....	3-3
3.1.1. 2x20 Display (option)	3-3
3.2. Other Options.....	3-4
3.2.1. Three-Track MSR (option)	3-4
3.2.2. Keypad/MSR (option).....	3-5
3.3. Peripherals.....	3-5
Chapter 4 - SITE PREPARATION.....	4-1
4.1. Unpacking and Inspection.....	4-1
4.2. Reporting Shipment Damage	4-2
4.3. Returning Equipment	4-2
4.4. Using Anti-static Protection.....	4-2
4.5. Preparing for Installation	4-3
4.6. Determining Power Requirements	4-3
4.7. General Requirements.....	4-3
4.7.1. General Electrical Supply Requirements	4-4
4.8. Installation with Other Equipment.....	4-6
4.8.1. Terminals at 100-240 Volts	4-6
4.8.2. Mains Power Cables	4-7
4.8.3. Warning Labels.....	4-7

Table of Contents (continued)

Chapter 5 - Installation	5-1
5.1. Installing Options.....	5-1
5.1.1. Installing the MSR	5-2
5.1.2. Installing the MSR/Keypad.....	5-5
5.1.3. Installing the 2x20 Display	5-7
5.2. Installing Peripherals	5-8
5.3. Connecting Peripherals	5-9
5.4. Connecting Power	5-11
Chapter 6 - General Operations	6-1
6.1. System Operations	6-1
6.1.1. General Care and Maintenance	6-1
6.1.2. Power ON and OFF Sequence	6-2
6.1.3. Powering ON	6-3
6.1.4. Powering OFF	6-3
Chapter 7 - Maintenance.....	7-1
7.1. Periodic Maintenance.....	7-1
7.2. Power ON and OFF Sequence	7-1
7.2.1. Powering On	7-2
7.2.2. Powering Off.....	7-2
7.3. Replacements	7-2
7.3.1. Replacing the Motherboard.....	7-3
7.3.2. Changing Motherboard Settings	7-4
7.3.3. Replacing the CPU.....	7-8
7.3.4. Replacing the Motherboard Fan.....	7-10
7.3.5. Adding or Replacing Memory	7-11
7.3.6. Replacing the Hard Drive	7-12
7.3.7. Replacing the Power Supply	7-13
7.3.8. I/O Panel	7-14
Chapter 8 - Troubleshooting.....	8-1
8.1. Power cannot be turned on or the unit powers off after a few minutes.	8-1
8.2. System will not boot up	8-2
8.3. Display/LCD shows correctly during Power On Self Test (POST), but fails when the Operating System (OS) starts	8-3
8.4. Display/LCD is blank at all times.....	8-4
8.5. Deletion of date, time and disk setup data when turning off power	8-5
8.6. MSR reading error	8-5
8.7. Customer display errors	8-6
8.8. Operation errors of other peripheral devices	8-7

Table of Contents (continued)

Chapter 9 - BIOS	9-1
9.1. Main Menu.....	9-2
9.2. Standard CMOS Features	9-2
9.3. Advanced Bios Features	9-3
9.4. CPU Features	9-4
9.5. Hard Disk Boot Priority	9-4
9.6. Advanced Chipset Features.....	9-5
9.7. Integrated Peripherals	9-5
9.8. USB Configuration	9-6
9.9. OnChip IDE Device.....	9-6
9.10. Onboard Device	9-7
9.11. Super I/O Device.....	9-7
9.12. Power Management Setup	9-8
9.13. PnP/PCI Configurations.....	9-8
9.14. Frequency/Voltage Control.....	9-9
9.15. Hardware Monitoring.....	9-10
9.16. Event Log.....	9-11
9.17. Others.....	9-11
9.18. System Information.....	9-12
9.19. Set Supervisor/User Password	9-12
 Chapter 10 – Spares and Upgrade Parts List.....	 10-1

Figures

Figure 1-1. TeamPoS 3000 XT Front and Back Views	1-1
Figure 1-2. TeamPoS 3000 XT Control Unit Flow Diagram	1-2
Figure 1-3. Side Panel LEDs and Switch.....	1-3
Figure 3-1. TP3000 XT Dimensions (for units with 12.1" LCD).....	3-2
Figure 3-2. TP3000 XT Dimensions (for units with 15" LCD).....	3-2
Figure 3-3. LCD Audio and Brightness Adjustments.....	3-3
Figure 3-4. Optional 2x20 Display Dimensions	3-3
Figure 3-5. Optional 2x20 Display Installed.....	3-3
Figure 3-6. MSR added to LCD.....	3-4
Figure 3-7. MSR and Keypad added to LCD	3-5
Figure 4-1. Warning Label on Back of Unit	4-7
Figure 4-2. Label on Front of Power Supply	4-8
Figure 4-3. Label on Left Side of Power Supply	4-8
Figure 4-4. Label on Right Side of Power Supply	4-9
Figure 4-5. Label on Motherboard.....	4-9
Figure 4-6. Label on PC Shield.....	4-9
Figure 5-1. TP3000 XT with MSR	5-2
Figure 5-2. TP3000 XT with MSR/Keypad.....	5-5
Figure 5-3. TP3000 XT with 2x20 Display	5-7
Figure 5-4. Keylock Location	5-9
Figure 5-5. Access to the I/O Panel	5-9
Figure 5-6. I/O Panel Details	5-10
Figure 5-7. Cover Removal Tool Storage Location.....	5-11
Figure 5-8. Using a Screwdriver to Remove Power Supply Cover	5-11
Figure 5-9. Power Supply Panel	5-12
Figure 7-1. Removing the Top Cover and PC Shield	7-4
Figure 7-2. White Release Lever	7-5
Figure 7-3. Removing the Motherboard	7-5
Figure 7-4. Motherboard Jumper Locations	7-6
Figure 7-5. Removing the CPU Heatsink	7-8
Figure 7-6. CPU Heatsink and Retaining Bracket	7-9
Figure 7-7. Removing the CPU	7-9
Figure 7-8. Removing the Fan Bracket from the Motherboard	7-10
Figure 7-9. Removing the Fan from the Bracket	7-10
Figure 7-10. Adding/Replacing Memory.....	7-11

Tables

Table 1-1. TeamPoS 3000 XT Side Panel Switch and LCDs.....	1-4
Table 4-1. Power Requirements.....	4-6
Table 7-1. Motherboard Switch and Jumper Settings.....	7-7

This page intentionally blank.

Chapter 1 - Overview

For the TeamPoS 3000 XT point of sale terminal, this manual describes in detail the procedures required for field installation and maintenance, including site preparation, equipment inspection, BIOS setting, and troubleshooting the controller.

The following sections provide a brief overview of the TeamPoS 3000 XT.



Figure 1-1. TeamPoS 3000 XT Front and Back Views

Note: The photo above a typical configuration. Depending on the store environment, the configuration and components may differ.

The TeamPoS 3000 XT is a state-of-the-art, all in one, Point-of-Sale (PoS) terminal designed for installations where space is at a premium. The TeamPoS 3000 XT offers functionality required by retail application software and is "retail hardened" to support the environments found in most retail stores. Memory capacity and CPU type and speed are selectable.

Built on an industry standard platform, the TeamPoS 3000 XT leverages Intel embedded components and standard operating systems, software applications and peripherals. It supports standard PC components such as high-performance CPUs, memory, and hard disk. A variety of outputs are offered to connect industry standard peripherals.

This controller offers a 2.5" hard disk drive, on board LAN, 12.1 or 15" LCDs and a variety of operating systems.

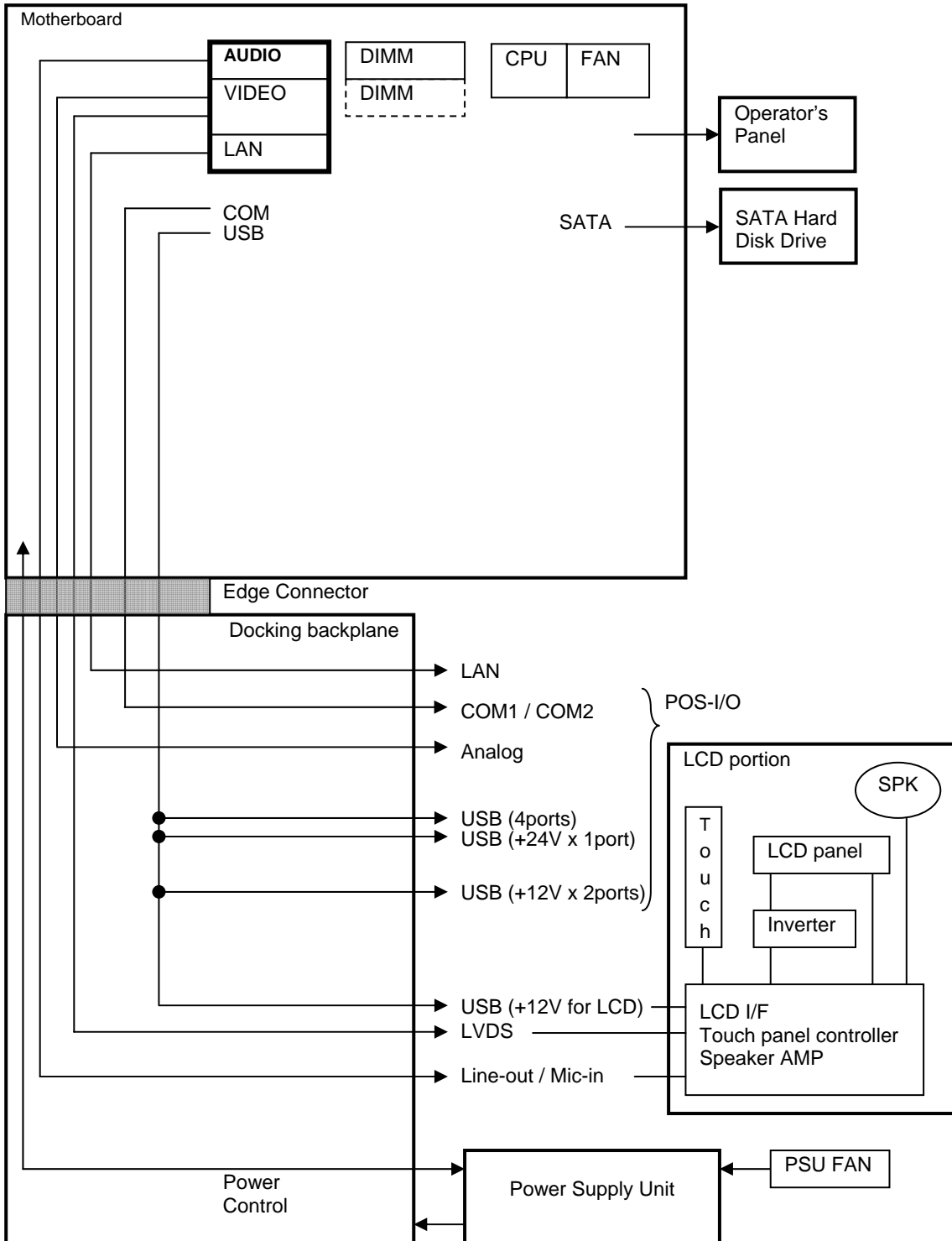

Figure 1-2. TeamPoS 3000 XT Control Unit Flow Diagram





1.1 Side Panel LEDs and Switch

LEDs and the power switch are located on the left side of the LCD. The Port Switch is on the I/O panel described in Chapter 7. The following photo and table show the TeamPoS 3000 XT unit LEDs and switches.



Figure 1-3. Side Panel LEDs and Switch

Table 1-1. TeamPoS 3000 XT Side Panel Switch and LEDs

Symbols	Name Switch/LED	Mounting Position	LED Color	Remark
	Power Switch	Under drop down window in front panel	n/a	Depending on the BIOS setup, the power switch can be instant off or delayed off.
	Power LED	LCD left side.	Green	Indicates AC power is supplied to the power supply and all DC voltages are available to the motherboard and other devices.
	Not used	LCD left side.	n/a	Not used
	HDD LED (Hard Disk Drive)	LCD left side below the Battery Backup LED.	Green	Indicates hard disk drive activity.
	LAN LED	LCD left side below the HDD LED.	Green	Indicates activity on the LAN when lit.
	Reset Switch	On I/O panel.	n/a	Not used.
	Dump Switch (not used)	On I/O panel.	n/a	Not used.
	Port On/Off Switch	On I/O panel.	n/a	Default setting is "ON" (right position). Turns on/off power to all RS232 ports (including COM 1 & COM 2).
	Port On/Off LED	On I/O panel.	Green	Indicates power is on to ports.

1.2 Intelligent PINs (Product Identification Numbers)

Depending on the application requirements, a large variety of configurations are possible. Intelligent PIN Configuration options are shown below.

1st Digit Chassis	2nd Digit Motherboard	3rd Digit CPU
M Kiosk 12.1" Resistive/Black N Kiosk 15" Resistive/Black O Kiosk 15" IR/Black	M OPN TP3K Motherboard/SHE	1 1.3 Celeron M 2 1.5 Celeron M 3 1.6 Pentium M 4 2.0 Pentium M

4th Digit Memory	5th Digit Future Option	6th Digit Hard Disk
1 DDR 256 MB 2 DDR 512 MB 4 DDR 1 GB 5 DDR 1 GB x2	0 Always 0	0 No Hard Disk 1 HDD 2.5" 40 GB 2 HDD 2.5" 80 GB

7th Digit Future Option	8th Digit Future Option	9th Digit Operating System
0 Always 0	0 Always 0	0 None 4 OEM Windows 2000 Pro, Preloaded 6 OEM Windows XP Pro, Preloaded 7 OEM Windows Ape, Server Downloaded 9 OEM Windows XP Embedded, Preloaded A Win2003 SVR inch 5 CAL, preloaded B WXPPO OEM Unrestricted W WEPOS

10th Digit Future Option	11th Digit Power Cord	12th Digit Future Option
0 Always 0	0 No power cord 6 CBL TP3K Mains/U.S./BLK	0 Always 0

13th Digit Spare	14th Digit Spare	15th Digit RoSH Compliance
0 N/A 1 OPN MSR 3-Track/D22&D25/BLK 2 OPN Keypad MSR/D22&D25/BLK	0 N/A No wireless option	0 Not RoHS compliant R RoHS compliant

This page intentionally blank.

Chapter 2 - Specifications

This chapter lists electrical, environmental, and regulatory compliance specifications for the TeamPoS 3000 XT.

Electrical Specifications		
Power requirements	Voltage	100-240 VAC
	Frequency	50/60Hz
EMI, ESD		FCC Class-A/ 15KV ESD, conforms to CISPR24 and EN55024
Environmental Specifications		
Temperature °C (°F)	Operating	0~40 (32~104)
	Not operating	-5~50 (23~122)
Humidity (%) (Non-condensing)	Operating	10~95% RH
	Not operating	8~95% RH
Vibration (G)	Operating	0.1G 3 ~ 100Hz 0.2G 2 ~ 10Hz 1.0G 100 ~ 350Hz
	Not operating	0.4G 3 ~ 60Hz 2.0G 100 ~ 350Hz
Noise (dB)		33dB or less.
Regulatory Compliance		
RFI		- FCC 47CFR Part 15 class A - ICES-003 Issue 4 class A - EN55022 - VCCI class A - AS/NZS CISPR22:2002 class A - GB9254:1998 class A - CNS13438 class A
Safety		- CAN/CSA-C22.2 No. 60950-1-03 1st Edition - EN60950-1:2001 - UL60950-1 1st Edition - GB4943-2001

This page intentionally blank.

Chapter 3 - Dimensions

This section shows the dimensions of the TeamPoS 3000 XT.

Note: All dimensions are expressed as mm (inches).

The TeamPoS 3000 XT is available with a 12.1 or 15" LCD, and in black only.

Physical			
		12.1" LCD	15" LCD
External dimensions mm (inches)	Width	30.5 cm (12 in.)	36.2 cm (14.25 in.)
	Depth	29.2 cm (11.5 in)	29.2 cm (11.5 in.)
	Height	40.9 cm (16.1 in)	43.2 cm (17. in.)
Weight kg (lbs)		12.8 kg (28.3 lbs)	13.6 kg (30.06 lbs)



Figure 3-1. TP3000 XT Dimensions (for units with 12.1" LCD)



Figure 3-2. TP3000 XT Dimensions (for units with 15" LCD)

3.1 Displays

The LCD is an integral part of the TP3000 XT and cannot be upgraded in the field. Both the 12.1 and the 15" LCDs are available as non-touch, 5-wire resistive. The 15" LCD is also available with infrared touch.

All LCDs come with a audio and brightness adjustment dials on the bottom edge.



Figure 3-3. LCD Audio and Brightness Adjustments

3.1.1 2x20 Display (option)

Installation of the 2x20 displays option does not increase the overall space requirements for the unit. Installation instructions are included in Chapter 5.

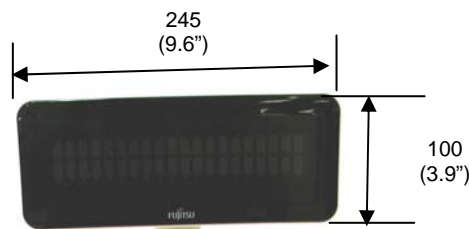

Figure 3-4. Optional 2x20 Display Dimensions



Figure 3-5. Optional 2x20 Display Installed

3.2 Other Options

Options include a 3-track MSR and a 5x8 keypad/MSR.

3.2.1 Three-Track MSR (option)

An optional 3-track magnetic stripe reader can be mounted to the right side of the display. It adds 508 mm (two inches) to the width of the LCD. Installation instructions are included in Chapter 5.



Figure 3-6. MSR added to LCD

3.2.2 Keypad/MSR (option)

An optional 5x8 magnetic strip reader and keypad combination can be attached to the LCD. Installation instructions are included in Chapter 5.



Figure 3-7. MSR and Keypad added to LCD

3.3 Peripherals

The TP3000 XT supports industry standard peripherals which are connected at the I/O ports.

This page intentionally blank.

Chapter 4 - Site Preparation

This chapter provides the following pre-installation details for the TeamPoS 3000 XT:

- Shipment inspection and return
- Anti-static protection
- Electrical supply requirements
- Mains power cables
- Warning labels

The procedures assume that in-store wiring for terminals, peripherals, and terminal-to-terminal communications have been installed.

4.1. Unpacking and Inspection

TeamPoS Series terminals are thoroughly inspected prior to shipment; however, damage can occur during transit. Any damage to the terminal can lead to problems after installation. Before accepting a shipment, inspect all shipping containers for external damage. Ensure that all packages listed on the shipment billing form have been delivered. Carefully unwrap and inspect all equipment:

- Inspect the exterior of each shipping box noting damage on the shipping documents so that the carrier has a record.
- Verify that all the accessories listed on the packing list have been included in the shipment. Report shortages and damage to CustomerCare. The customer needs to provide the sales order number and a description of the piece of equipment damaged. The customer should then telephone 1-800-780-5525 and a CustomerCare representative will arrange for replacement. CustomerCare is not responsible for equipment damaged by the customer after it is delivered.
- Inspect the exterior of each unit for any obvious physical damage (scratches or abrasion on painted or display surfaces, or on plastic surfaces) that could have occurred during shipping.
- Damaged equipment received from a source other than Fujitsu Transaction Solutions Inc.'s Foothill Ranch facility should be reported to the sender.

4.2. Reporting Shipment Damage

If any damage is detected, both the recipient and the carrier are responsible for reporting the damage. Follow all applicable policies and procedures for notifying the carrier, management, and Fujitsu Transaction Solutions of the damage, and for filing damage claims.

Note: all components are packaged separately. Keep the packaging in case it is necessary to return any of the components.

4.3. Returning Equipment

All equipment returned to the factory must be packed in either the original container or a substitute container of equal strength and durability. Packing material, about 76.0 mm (3.0 inches) thick, should surround all protruding edges, switches, and surfaces. Parts shipped in a package separate from the unit must also be repacked and included in the return. Each return must include the following information:

- Description of the equipment defect
- RMA number (received from CustomerCare representative)
- Order number
- Date received
- Name, address, and phone number of the person making the return

4.4. Using Anti-static Protection

When installing and disassembling equipment, be sure to follow anti-static protection procedures. All controllers, terminals, peripherals, and boards are susceptible to damage due to electrostatic discharge. Insufficient anti-static protection when handling boards causes failure, degraded operation, and reduced reliability.



Caution: Avoid touching connector pins on data cables or boards. Touching exposed connector pins could cause a discharge into the circuitry resulting in failed components.

4.5. Preparing for Installation

Before installing equipment, perform the following steps:

- Move all terminal components, accessories, and cables to the locations specified in your local site plan.
- Position the cables according to the site plan. Make sure you have the correct data cable at each terminal location.
- Place the optional equipment next to the terminal to which it will be connected.
- Remove the shipping tape from those components that have been taped.

4.6. Determining Power Requirements

This section provides the electrical supply data and main power cable information to prepare a site for the installation of the TeamPoS 3000 XT terminal. This product is also designed for IT power systems with phase-to-phase voltage of up to 240V.

Electrical power to the equipment must comply with all local, state, and national wiring codes and meet the requirements described here. If you do not have qualified in-house personnel to ensure that power requirements are met, an electrical contractor familiar with computer equipment should be hired.



Caution: To prevent data loss, do not plug equipment that can produce sudden surges (i.e., vacuum cleaners) into the power circuit used by the terminal.

4.7. General Requirements

1. The safety standards for Information Technology Equipment are only valid if the building installation conforms to the National Electrical Code for the country where the equipment is being installed.
2. For equipment that has a pluggable connection to its power source, the power source outlet must be located near the equipment and must be easily accessible.

3. For protection against electric shock, certain parts of this equipment, including the interface connections, have been designed so that the voltage is limited to a safe value. To maintain this protection, it is essential that all equipment connected to Fujitsu products have interface connections which are similarly protected.
4. When installing and disassembling equipment, be sure to follow anti-static protection procedures. All controllers, terminals, peripherals, and boards are susceptible to damage due to electrostatic discharge. Insufficient anti-static protection when handling boards may cause failure, degraded operation, and/or reduced reliability.

4.7.1. General Electrical Supply Requirements

1. Line noise limitations must not exceed 1250V with a maximum 1 μ s duration, and the repetition rate not to exceed 100Hz.
 2. Socket outlets must provide protective earth grounding and be of a polarized type.
 3. Before installing the terminal, check the power lines for loads that could cause large variations in voltage. Electrical devices that use a great deal of power such as air conditioners, elevators, copying machines, and large motors can cause large drops in voltage. When severe electrical interference occurs, installing radio frequency (FRO) filters, isolation transformers, or both may be necessary. If voltage surges caused by lightning are likely to occur, install an arrester.
 4. Fujitsu-supplied cables should be used to connect the system to the power supply outlet but where this is not possible, the minimum requirement for the mains cables is as follows:

For connection to 100-240V phase-to-neutral power supply systems, power supply cord to be rated at phase-to-neutral power supply systems; power supply cord to be unshielded and rated at 5 amps (minimum), 240 volts with one end terminated in a plug suitable for that location and the other end terminated in an ICE type CAE-22 female connector.

5. This ITEM is designed for use on a power system with a grounded neutral; i.e., a TN or TTS power system. The terminals must not be directly connected to a power system with an impedance grounded neutral; i.e., an IT power system.

For pluggable equipment, the supply plug shall be connected as follows:

Black or Brown	Live (Hot)
White or Blue	Neutral
Green or Yellow	Ground/Earth

To the User:

- DO read the operating instructions carefully before you attempt to use this equipment.
- DO ensure that the supply connector or isolator is readily accessible to enable isolation of the equipment.
- DO ensure that a competently trained person checks that all electrical connections (including the supply plug and any extension leads) are properly made in accordance with the instructions.
- DO NOT allow the supply cord to be positioned where it may be snagged, trodden-on or stretched across sharp edges.
- DO NOT continue to operate the equipment if you have ANY doubt about it working normally, or if it is damaged in any way. Instead, switch it off and, if the equipment is pluggable, remove the supply cord and contact your local service agent.
- DO NOT remove any fixed covers unless you are qualified / authorized to do so for the preparation of the equipment. No user serviceable parts are under the covers unless expressly indicated in this manual. Always remove the power supply plug from the power source before removing any covers, and ensure ALL covers are replaced and correctly secured before re-connecting the power supply plug.
- DO NOT obstruct any of the ventilation slots in the equipment. Obstruction of these slots can cause overheating, reduce equipment reliability and shorten equipment life.
- DO NOT expose the equipment to spilled liquids.
- DO NOT replace the power supply cable with a different type than called for in the this manual or supplied with the equipment.

4.8. Installation with Other Equipment

In most cases, dedicated AC mains circuits are not required for the TeamPoS 3000 XT terminals. In rare instances, other electrical equipment sharing power with the terminal may cause adverse effects on the terminal. When this occurs, electrical isolation may be required and is the responsibility of the customer or installing contractor.

4.8.1. Terminals at 100-240 Volts

Table 4-1 details the power requirements for the TeamPoS 3000 XT control unit.

Table 4-1. Power Requirements

Property	Value or Description
Grounding	The terminals are Class 1 equipment and must be supplied via a socket outlet with a protective ground contact connected to the protective ground of the terminal.
Power system	The terminals are designed for use on a power system with a grounded neutral; i.e., a TN or TTS power system. The terminals must not be directly connected to a power system with an impedance-grounded neutral; i.e., an IT power system.
Rated voltage and frequency	100 - 240 volts, 50/60 Hz
Rated current	3.6 A
Operational frequency limits	47 – 63 Hz
Earth leakage current	< 1.0 am
Power dissipation	250 watts
Maximum HARK fuse rating for external short-circuit protection	20 A
Main power cord:	
Length	3.00 m (9.80 ft.)
Diameter	8.0 mm (0.30 in.)
Minimum bend radius	10.0 mm (0.40 in.)

4.8.2. Mains Power Cables

The mains power cables for the TeamPoS 3000 XT terminals are terminated with a plug suitable for the ordering country.



Caution: The power supply cord is used as the main disconnect device. Ensure that the socket-outlet is located/installed near the equipment and is easily accessible.

4.8.3. Warning Labels

The equipment contains warning labels shown below.

Do not remove any warning label. If a label becomes damaged or soiled to the point where it is illegible, contact your Customer Service Engineer.



Figure 4-1. Warning Label on Back of Unit

Additional labels can be viewed when the LCD is tilted backwards to expose the power supply.

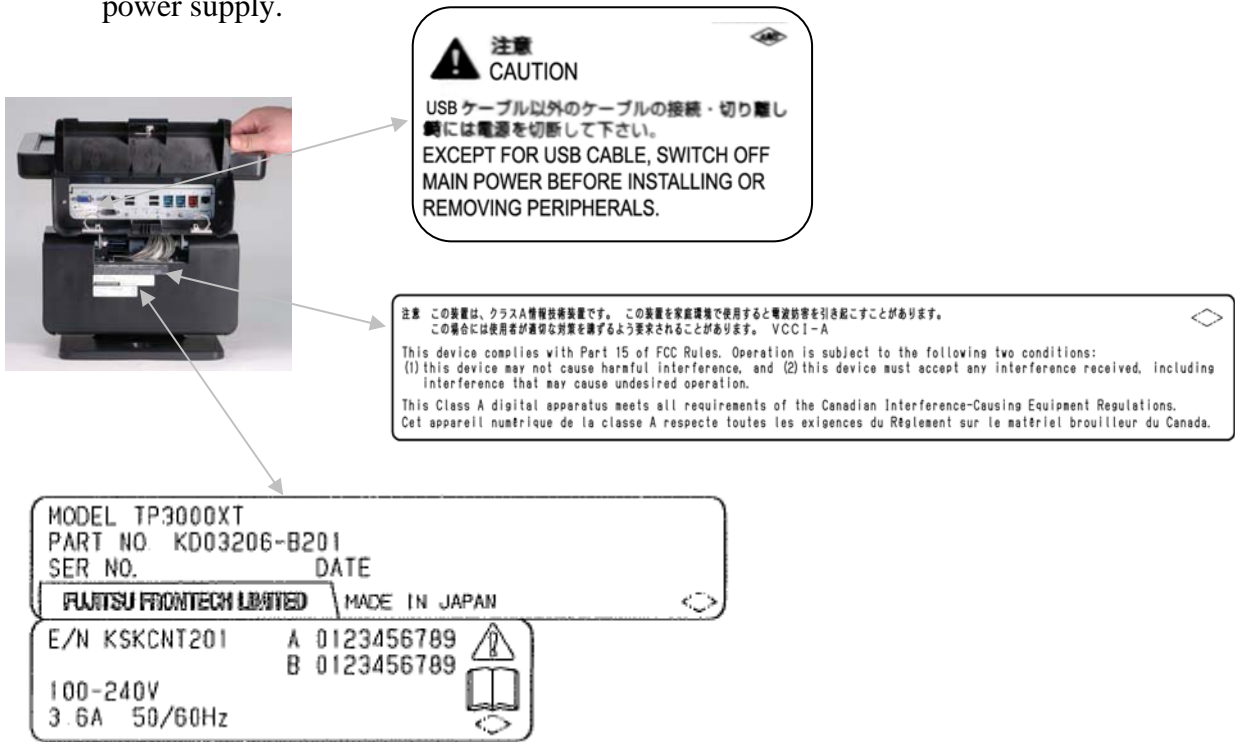

Figure 4-2. Label on Front of Power Supply

Additional labels are located on the power supply and are visible when the access panels are removed.



Figure 4-3. Label on Left Side of Power Supply

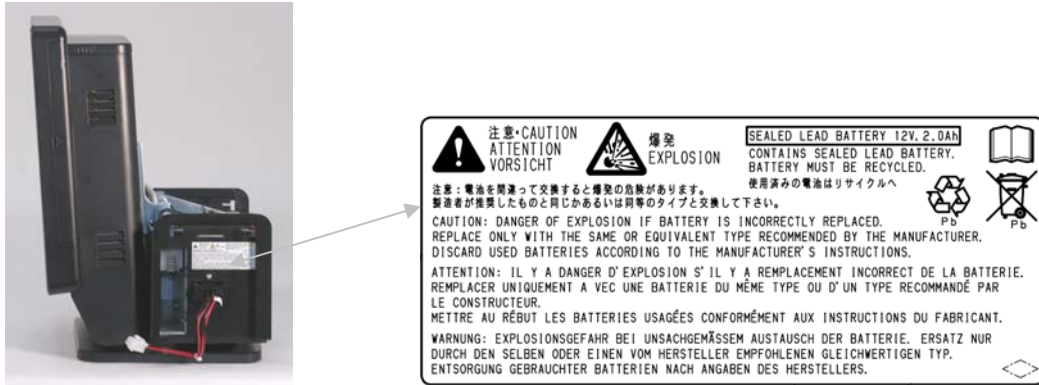

Figure 4-4. Label on Right Side of Power Supply



Figure 4-5. Label on Motherboard



Figure 4-6. Label on PC Shield

This page intentionally blank.

Chapter 5 - Installation



Caution: Confirm that the external power source is 100-240 VAC before starting the operation. To prevent electric shock, confirm that the AC cable is removed from the AC outlet anytime the panels are removed. Be sure to observe all ESD precautions and power OFF procedures.

The TeamPoS 3000 XT ships completely assembled (with the exception of options). The following tasks are required for installing the unit:

- Install any options
- Connect peripherals
- Connect power.



Caution: With the exception of USB peripherals, never disconnect or connect a peripheral while power is on its port. To avoid damage to the control unit and peripherals, when connecting and disconnecting RS232 peripherals, turn power OFF with the Port switch, the TeamPoS 3000 XT power switch on the left side of the unit or by disconnecting AC power.

5.1. Installing Options

Two options can be installed on the LCD: an MSR and MSR with keyboard. An additional display can also be installed. Procedures for their installation are provided in the following sections.

5.1.1. Installing the MSR



Figure 5-1. TP3000 XT with MSR

To install the MSR:

1. Be sure power is disconnected from the unit.
2. Gently press in and up on the arrow icon on the right side panel to remove it. Discard the panel.



3. Remove the back cover by pushing in on the latch at the bottom and long edge, then lift off the back cover.

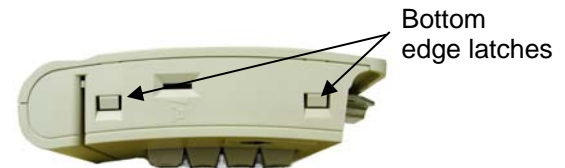
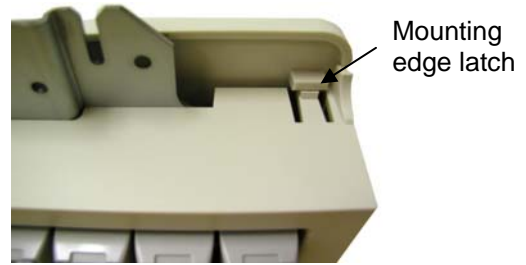

4. Remove the tape holding the cable connector. Ease the connector cable out of the side of the LCD. Connect the plug to the MSR board.

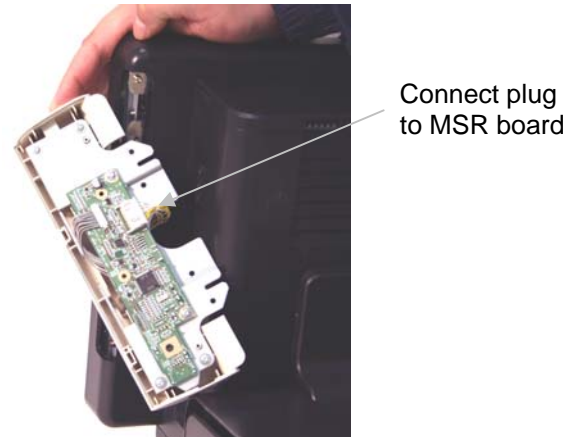

5. Slide the board into the grooves in the top of the chassis. Be sure the cable is not pinched between the MSR and LCD. Secure with two screws.

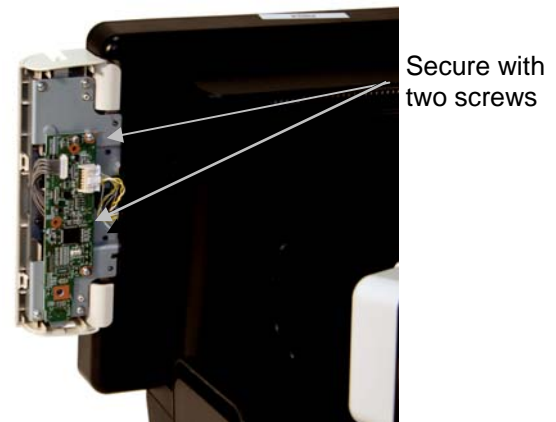

6. Snap the MSR cover into place. Align the top and outer edges first, then ease the tabs at the lower edge inside the shell until they snap into the notches.



5.1.2. Installing the MSR/Keypad



Figure 5-2. TP3000 XT with MSR/Keypad

To install the MSR/keypad:

1. Be sure power is disconnected from the unit.
2. Remove the right side panel from the LCD by sliding it off.

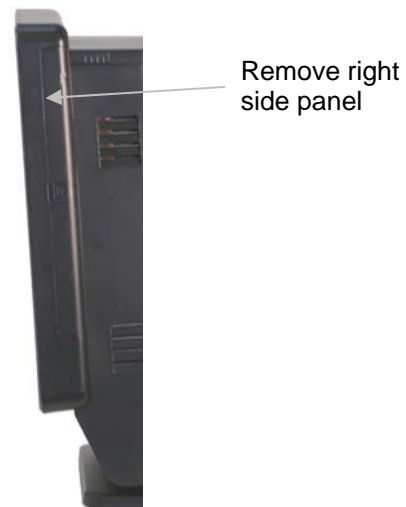

3. Remove the back cover by pushing in on the latches at the bottom and long edge, then lift off the back cover.

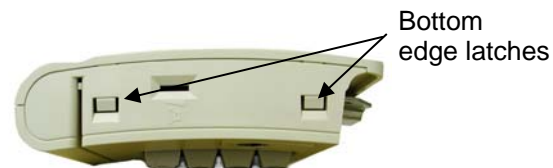
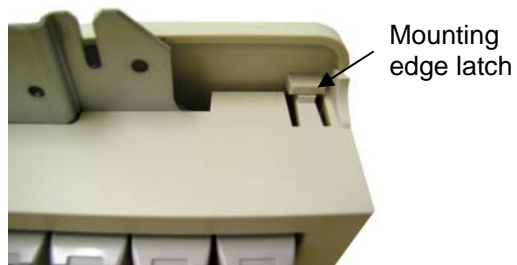

4. Connect the plug to the MCR-keypad.



5. Slide the board into the grooves in the top of the chassis. Secure with two screws.

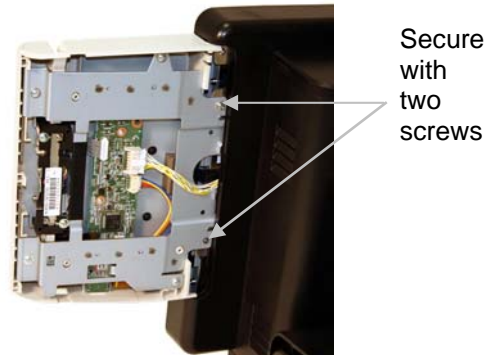

6. Snap the MSR cover into place. Align the top and outer edges first, then ease the tabs at the lower edge inside the shell until they snap into the notches.

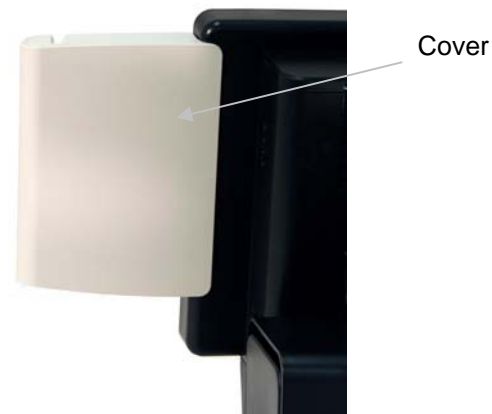

5.1.3. Installing the 2x20 Display

The 2x20 display is mounted to the top of the power supply.



Figure 5-3. TP3000 XT with 2x20 Display

To install the 2x20 display:

1. Be sure power is disconnected from the unit.

2. Remove the chassis cover plate by sliding it up and toward you.



3. Remove the two screws that secure the power supply cover. Lift the cover up and forward to remove it.

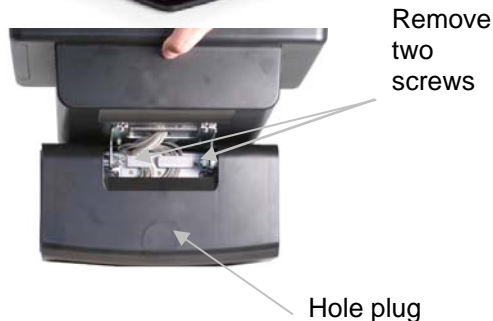

4. Remove the hole plug from the power supply cover.
5. Insert the 2x20 display into the power supply cover.

6. Route the cable on the back of the power supply.



7. Tilt the LCD back and open the access panel to the I/O panel.
Connect the cable to the 12V USB port on the I/O panel.



Connect
to
12V USB

8. Replace the access panel for the I/O panel.
9. Replace the power supply panel.
10. Replace the chassis cover plate.
11. When all peripherals and options have been installed, connect the power cord.

5.2. Installing Peripherals

The TeamPoS 3000 XT features an interface panel (see Figure 5-6) where peripherals may be connected. It includes the following connectors:

- VGA
- Two COM ports
- Four 5V USB ports
- Two 12V powered USB ports
- One 24V powered USB port
- One LAN connector.

5.3. Connecting Peripherals

Peripherals are connected at the interface panel which is located behind a locked panel. Before connecting peripherals, be sure you have the key to unlock the panel.



Figure 5-4. Keylock Location

To connect peripherals:

1. Tilt the LCD toward the back as shown in Figure 5-4.
2. Unlock the panel and lift the cover plate to expose the I/O panel.



Figure 5-5. Access to the I/O Panel

3. Connect peripherals to the appropriate connector. See Figure 5-6.
4. Route wires through the cable clamps.
5. Turn the Port switch to the ON position.
6. Close the cover plate and lock it.

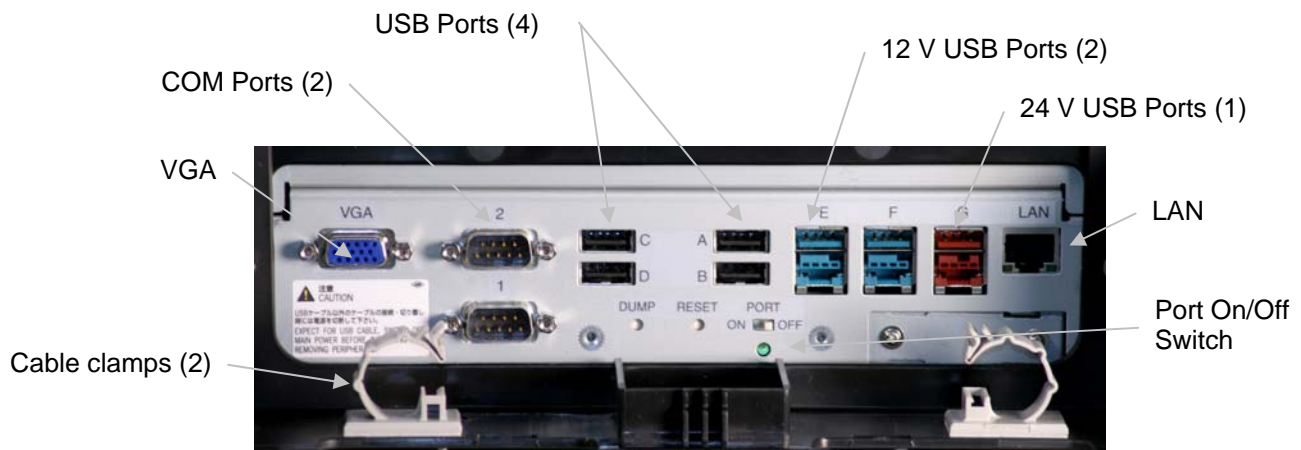

5.4. Connecting Power

To connect power to the unit:

1. Remove the cover from the left side of the power supply by inserting the special tool between the cover and the housing and pressing toward the edge of the housing to release the tabs. The tool is stored inside the interface panel as shown in Figure 5-7.



Figure 5-7. Cover Removal Tool Storage Location

If the special tool is not available, use a flat blade screwdriver.

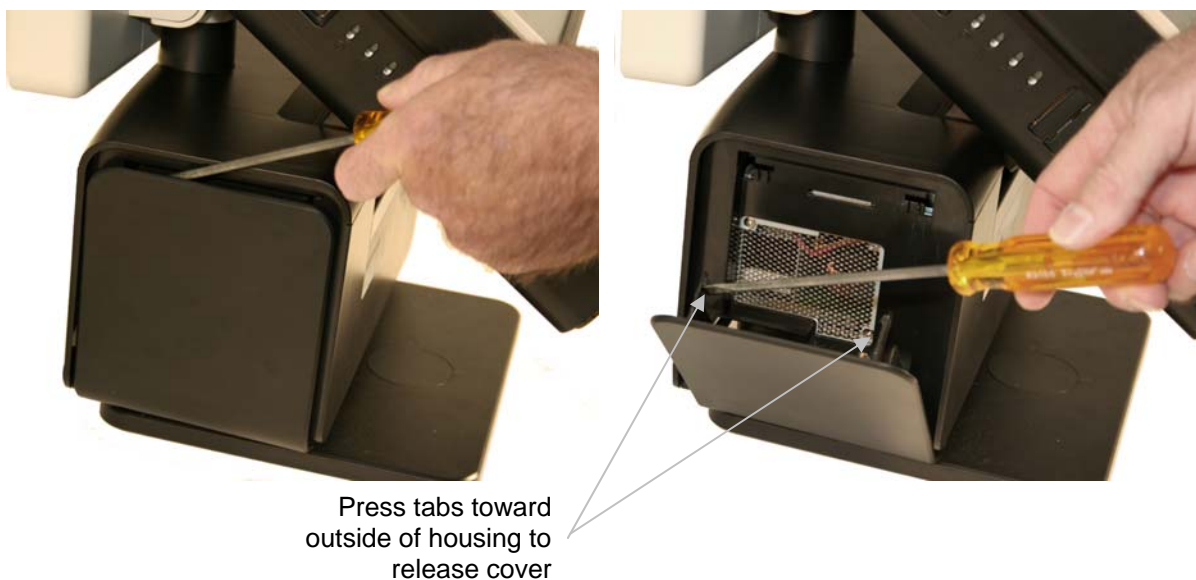

Figure 5-8. Using a Screwdriver to Remove Power Supply Cover

2. Plug the power cord into the socket and replace the power supply cover.



Figure 5-9. Power Supply Panel

Chapter 6 - General Operations

Note: The procedures in this chapter are intended for **store personnel**. The procedures in preceding and succeeding chapters are for **authorized service personnel only**.

6.1 System Operations

This section contains general and periodic care and maintenance, and power ON and OFF procedures for the TeamPoS terminals.

6.1.1 General Care and Maintenance

General cleaning of the terminal, peripherals, and MSR is required on a regular basis. In particular, dust must be removed from external components, air vents, fans, and exhaust screens to allow sufficient airflow to maintain proper internal operating temperatures. The frequency of this cleaning depends on installed environment. Lack of this cleaning will greatly reduce equipment reliability.

To achieve the maximum reliability of the optional MSR, cleaning with an MSR cleaner card must be performed approximately every 1,000 passes.

To keep the terminal and its peripherals in good working condition, follow the guidelines in this section.

1. Wipe the terminal and peripherals with a clean, soft cloth, dampened with water and mild soap. Never use abrasive pads or cleansers.
2. Handle the touchscreen with reasonable care. Clean the touchscreen with isopropyl alcohol 99% and lint-free wipes. Always dampen the wipes before cleaning the touchscreen.
3. If the keyboard or LCD has the MSR option installed, pass a magnetic stripe reader cleaner through the magnetic stripe reader to remove dust particles from the reader. The cleaner is a card covered with cloth on one side. Pass the card through the reader with the cloth side facing the MSR head. An embossed arrow on the keyboard shows where the MSR head is located.
4. Never remove covers from the control unit and peripherals while power is connected.
5. Keep the cover of the TeamPoS 3000XT terminal installed at all times unless the terminal is being serviced. The cover protects the cable connections and ensures adequate clearance for proper ventilation.

6. Make sure all cable connectors are securely installed on the terminal and peripherals to prevent the cables from being accidentally pulled off. Disconnecting and connecting cables (except USB cables) to the terminal while the power is on could cause damage to the terminal and its peripherals.
7. Do not expose the terminal to liquids. Although the units are designed to resist liquids from entering the internal components, liquids should be kept away from the terminal.

6.1.2 Power ON and OFF Sequence

This section presents the general procedures for powering the TeamPoS 3000XT control unit ON and OFF. The instructions in this section assume that the terminal, operating system, and the application software have been installed. For any additional power on and off procedures dictated by the retail application, refer to the manuals provided with your PoS application software.



Caution: With the exception of USB peripherals, never remove or connect any peripheral while power is on its port. To avoid damage to the control unit and peripherals, when connecting and disconnecting RS232 peripherals, turn power OFF with the ports OFF switch, the TeamPoS 3000XT power switch (on the left side of the unit) or by disconnecting AC power.

6.1.3 Powering ON

1. Make sure all peripherals are securely connected to the control unit.
2. Make sure the power cord is plugged into the power source.
3. Press the power switch on the side of the unit.
4. Confirm the power/battery status LED is ON and not blinking, indicating the successful completion of power-up diagnostics.

Any hardware errors detected on power up will appear on the display. Note that the Model VF60 two-line alphanumeric display does not display error messages.

6.1.4 Powering OFF

Note: Some peripherals, such as scanners and scales, may be separately powered. Check the peripheral manuals for instructions for these peripherals.

1. Press the power switch to turn OFF the terminal.

Note: Depending on BIOS setup, a momentary depression of the switch may signal the application to shut the unit down, which could take a few minutes. If power is not immediately turned off, either wait for the application to shut the unit down, or keep the switch depressed for approximately 4 seconds. For proper shutdown procedures, see the application software documentation.

This page intentionally left blank.

Chapter 7 - Maintenance



Caution: Confirm that the external power source is 100-240 VAC before starting the operation. To prevent electric shock, confirm that the AC cable is removed from the AC outlet anytime the covers are removed. Be sure to observe all ESD precautions and power OFF procedures.

This chapter covers periodic maintenance and provides instructions for installing and replacing those items which can be installed or replaced in the field.

7.1. Periodic Maintenance

Only trained personnel must perform the following:

Vacuum all ventilation passageways on the control unit and peripherals. Ensure that these passageways are open and free of dust and other debris that could restrict airflow.

Check the PSU fan for proper operation annually. See BIOS settings for typical fan speeds. If fan speed is approaching the low end, the fan should be replaced. Fan speeds can be found under the hardware monitoring section of the BIOS.

7.2. Power ON and OFF Sequence

This section presents the general procedures for powering ON and powering OFF the TeamPoS 3000 XT. The instructions in this section assume that the terminal, operating system, and the application software have been installed. For any additional power-up procedures dictated by the retail application, refer to the manuals provided with the application software.



Caution: With the exception of USB peripherals, never disconnect or connect a peripheral while power is on its port. To avoid damage to the control unit and peripherals, when connecting and disconnecting RS232 peripherals, turn power OFF with the Port switch, the TeamPoS 3000 XT power switch on the left side of the unit or by disconnecting AC power.

7.2.1. Powering On

1. Make sure all peripherals are securely connected to the control unit.
2. Make sure the power cord is plugged into the power source.
3. Lift the plastic switch cover at the left side of the control unit.
4. Press the power switch to turn the terminal ON.
5. Confirm the power/battery status LED is lit solid, indicating the successful completion of power-up diagnostics.

Note: Some peripherals, such as scanners and scales, may be separately powered. Check the peripheral manuals for instructions on powering on these peripherals.

Any hardware errors detected on power up will appear on the operator display (LCD). Note that the model VF 60 two-line alphanumeric display does not display error messages.

Note: Depending on setup, a momentary depression of the switch may signal the application to shut the unit down, which could take a few minutes. If power is not immediately turned off, either wait for the application to shut the unit down, or keep the switch depressed for approximately 4 seconds. For proper shutdown procedures, see the application software documentation.

7.2.2. Powering Off

1. Lift the plastic switch cover.
2. Press the power switch to turn OFF the terminal.

Note: For proper shutdown procedures, see the application software documentation.

7.3. Replacements

Subassemblies in the TeamPoS 3000XT cannot be repaired in the field, only replaced. For these tasks, you will need only a Phillips head screwdriver and a small flat blade screwdriver to replace the CPU and heat sink. The following sections provide details on the following tasks:

- Replacing the motherboard and changing motherboard settings
- Adding or replacing memory
- Replacing the hard drive
- Replacing the power supply
- Replacing the MSR or MSR/Keyboard (see Chapter 5)

- Replacing the CPU
- Replacing the chassis or CPU fan.

7.3.1. Replacing the Motherboard



Caution: Be sure to observe all ESD precautions and power off procedures.

To replace the motherboard:

1. Remove the AC cord from the back of the terminal.
2. Remove the top cover. See Figure 7-1.
3. Remove the two screws that retain the PC shield. Remove the shield.

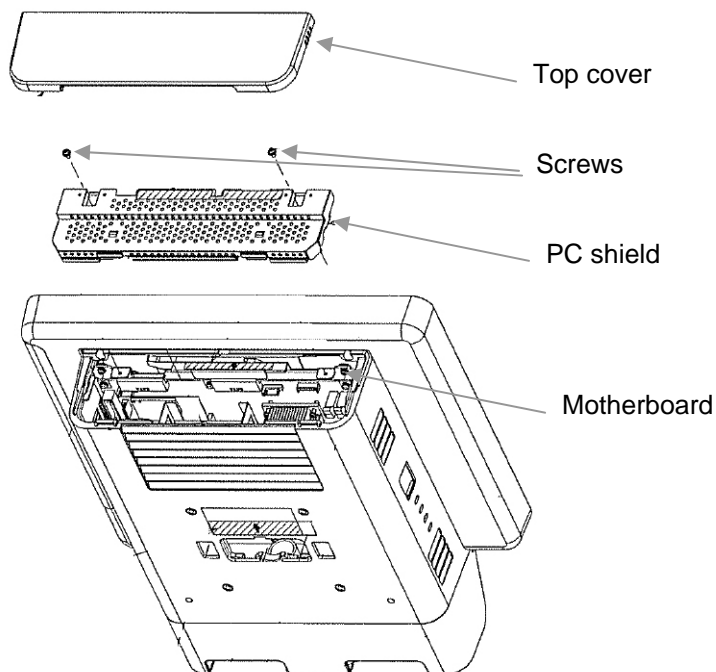

Figure 7-1. Removing the Top Cover and PC Shield

4. Disconnect the hard drive cable and power cable from to the motherboard.
5. Locate the white release lever on the top of the motherboard. Pull it up.

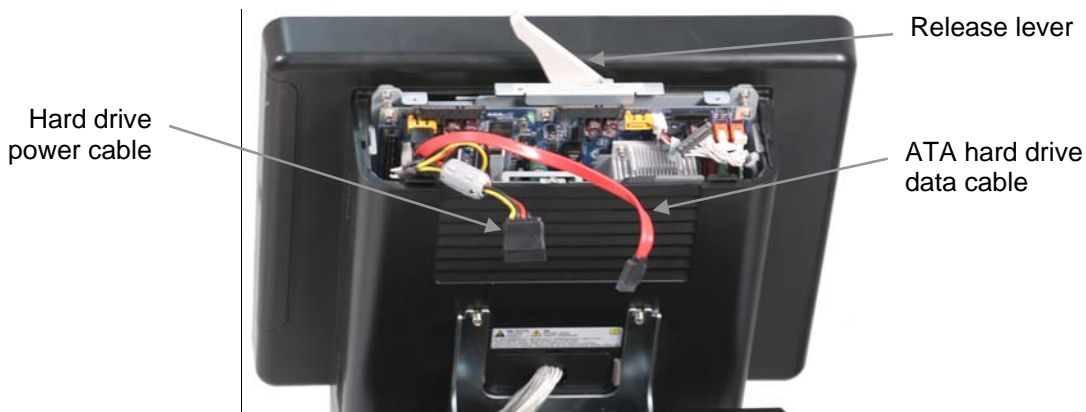

Figure 7-2. White Release Lever

6. If you are replacing the motherboard, be sure that the jumpers are set identically to the board you removed. Refer to the next section for details.



Figure 7-3. Removing the Motherboard

7. To reinstall the motherboard, make sure it lines up with the rails in the chassis.
8. Slide the motherboard into the chassis with the release lever at a 45° angle.
9. Push in slowly until the motherboard assembly engages the lever.
10. Use the lever to fully seat the motherboard assembly.
11. Reconnect the cables.
12. Reinstall the PC shield and the top cover.
13. Reconnect power.

7.3.2. Changing Motherboard Settings

Figure 7-4 and Table 7-1 show the TeamPoS 3000 XT motherboard with the position of the jumper settings. Explanation and default settings (**bold**) are provided on the following pages. When installing or exchanging the motherboard, be sure the settings are adjusted accordingly.

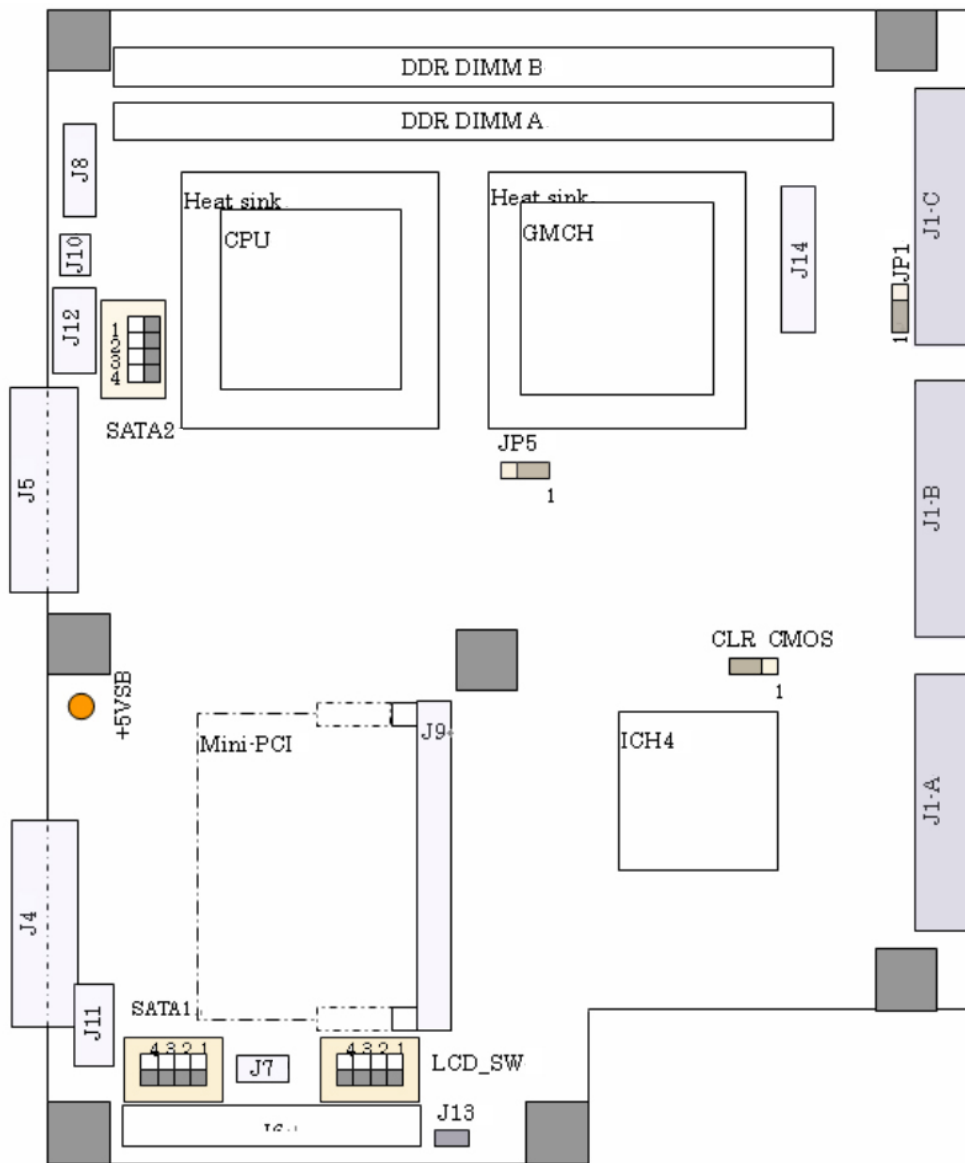

Figure 7-4. Motherboard Jumper Locations

Table 7-1. Motherboard Switch and Jumper Settings

Pin#	Function	Default Setting																				
JP1	Video source selection of 1st display 1-2 DVI Interface (for M/M) 2-3 LVDS Interface (for KIOSK)	1-2																				
JP5	VCCA voltage selection 1-2 VCCA is 1.3V for PentiumM and CeleronM with FSB 400MHz 2-3 Not used. For future use.	1-2																				
J13	Beep sound enable Short Beep sound enable Open Beep sound disable	Short																				
CLR_CMOS	CMOS Clear 1-2 CMOS Clear 2-3 Normal	2-3																				
LCD_SW	Panel selection for LVDS panel <table border="1" data-bbox="467 1003 1089 1171"> <thead> <tr> <th>1</th> <th>2</th> <th>3</th> <th>4</th> <th>Panel</th> </tr> </thead> <tbody> <tr> <td>OFF</td> <td>OFF</td> <td>OFF</td> <td>—</td> <td>12.1 inch SVGA</td> </tr> <tr> <td>ON</td> <td>OFF</td> <td>OFF</td> <td>—</td> <td>15 inch XGA</td> </tr> <tr> <td colspan="4">Other setting</td> <td>Reserved</td> </tr> </tbody> </table>	1	2	3	4	Panel	OFF	OFF	OFF	—	12.1 inch SVGA	ON	OFF	OFF	—	15 inch XGA	Other setting				Reserved	1...OFF 2...OFF 3...OFF 4...OFF
1	2	3	4	Panel																		
OFF	OFF	OFF	—	12.1 inch SVGA																		
ON	OFF	OFF	—	15 inch XGA																		
Other setting				Reserved																		
SATA1	Connector selection of 1st SATA HDD <table border="1" data-bbox="467 1247 1094 1436"> <thead> <tr> <th>1</th> <th>2</th> <th>3</th> <th>4</th> <th>Panel</th> </tr> </thead> <tbody> <tr> <td>ON</td> <td>ON</td> <td>ON</td> <td>ON</td> <td>J4 (for M/M)</td> </tr> <tr> <td>OFF</td> <td>OFF</td> <td>OFF</td> <td>OFF</td> <td>J11 (for KIOSK)</td> </tr> <tr> <td colspan="4">Other setting</td> <td>Prohibited</td> </tr> </tbody> </table>	1	2	3	4	Panel	ON	ON	ON	ON	J4 (for M/M)	OFF	OFF	OFF	OFF	J11 (for KIOSK)	Other setting				Prohibited	1...OFF 2...OFF 3...OFF 4...OFF
1	2	3	4	Panel																		
ON	ON	ON	ON	J4 (for M/M)																		
OFF	OFF	OFF	OFF	J11 (for KIOSK)																		
Other setting				Prohibited																		
SATA2	Not used.	n/a																				

7.3.3. Replacing the CPU



Caution: Be sure to observe all ESD precautions and power off procedures.

To replace the CPU:

1. Remove the AC cord from the back of the terminal.
2. Remove the motherboard as described in section 7.3.1, steps 1 – 6.
3. Disconnect the cable from the fan.
4. Remove the four screws from the heatsink.

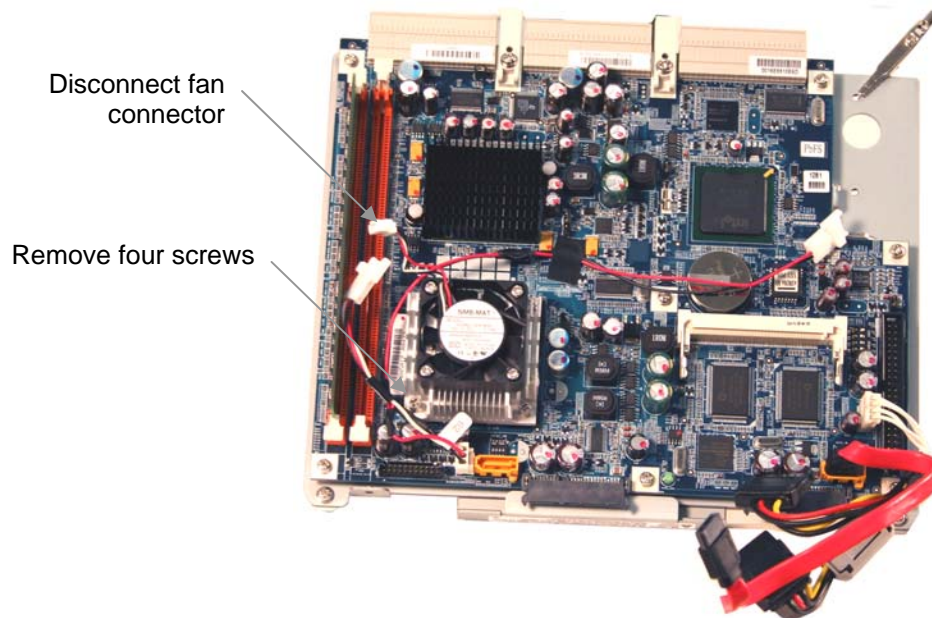

Figure 7-5. Removing the CPU Heatsink

5. Remove the heatsink and its retaining bracket which is on the back of the motherboard.

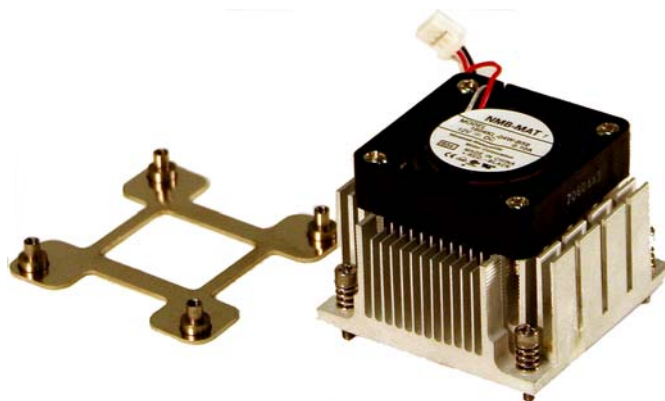

Figure 7-6. CPU Heatsink and Retaining Bracket

6. Remove the CPU by turning the retaining screw 1/2 turn counterclockwise.

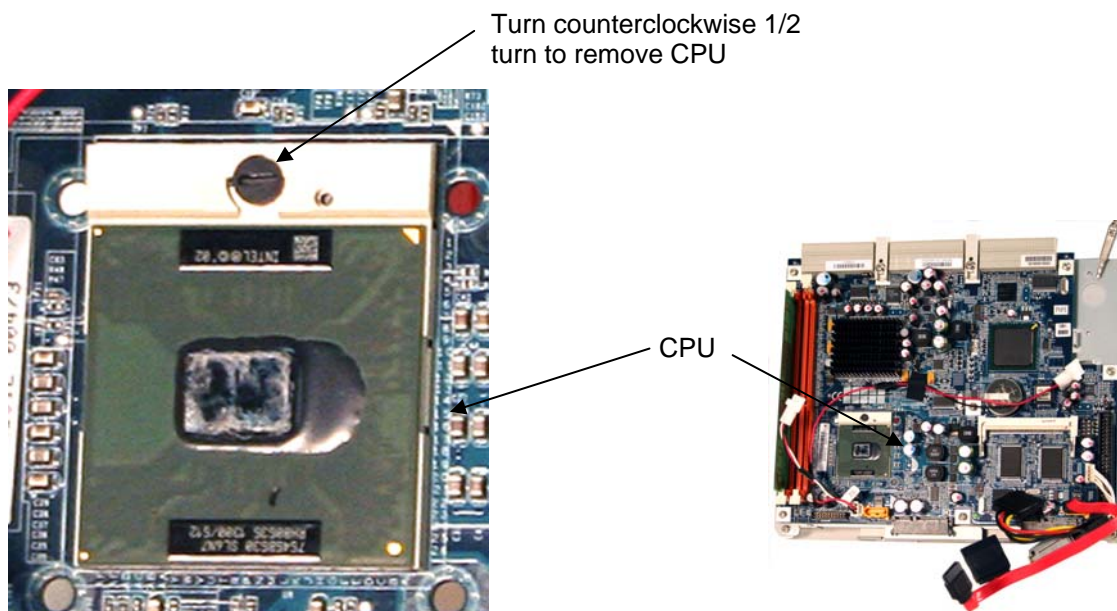

Figure 7-7. Removing the CPU

7. Install the new CPU and secure it by turning the retaining screw 1/2 turn clockwise.
8. Replace the heatsink and retaining bracket, fastening it with the four screws.
9. Connect the fan connector.
10. Replace the motherboard into the chassis.
11. If necessary, edit bios settings. Refer to section 9.4.

7.3.4. Replacing the Motherboard Fan

To replace the fan on the motherboard:

1. Remove the AC cord from the back of the terminal.
2. Remove the motherboard as described in section 7.3.1, steps 1 – 6.
3. Disconnect the fan connector.

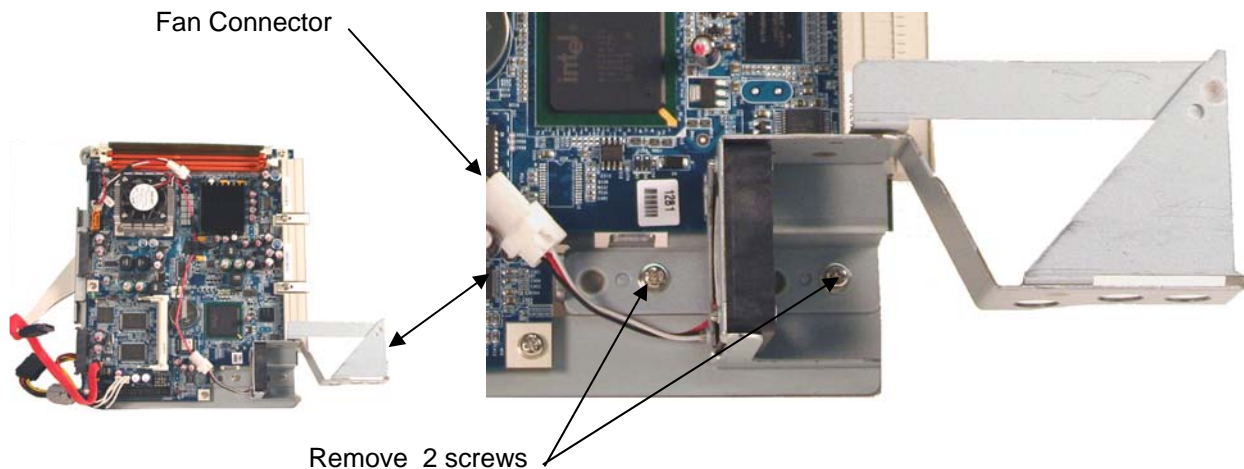

Figure 7-8. Removing the Fan Bracket from the Motherboard

4. Remove the fan bracket from the motherboard by removing two screws.
5. Remove the fan from the bracket by removing four screws.

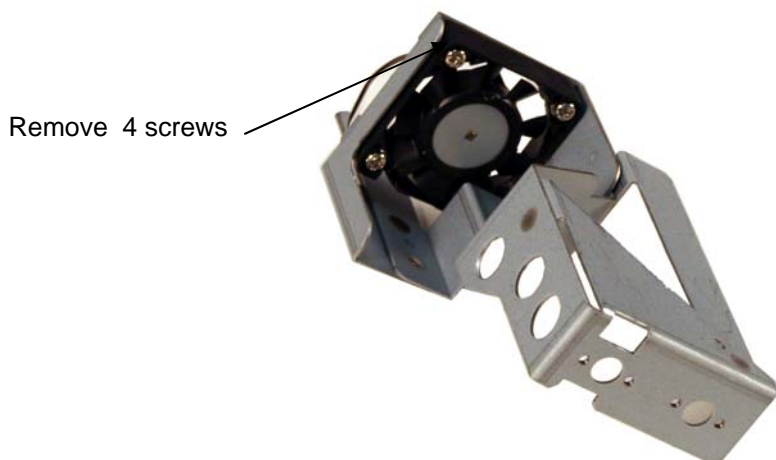

Figure 7-9. Removing the Fan from the Bracket

6. Attach the new fan to the bracket using the four screws removed in the previous step.
7. Attach the bracket to the motherboard using the screws removed in step 4.
8. Reconnect the fan connector removed in step 3.
9. Replace the motherboard into the chassis.

7.3.5. Adding or Replacing Memory



Caution: Be sure to observe all ESD precautions and power off procedures.

The TeamPoS 3000 XT has two memory sockets (slots) and can use 256MB, 512MB or 1GB memory in combination.

To add or replace memory:

1. Remove the AC cord from the back of the terminal.
2. Remove the motherboard as described in section 7.3.1, steps 1 – 6.
3. Flip the memory socket levers to the open position.
4. Insert memory (or additional memory) into an empty socket. (There is only one way the memory stick will fit.)

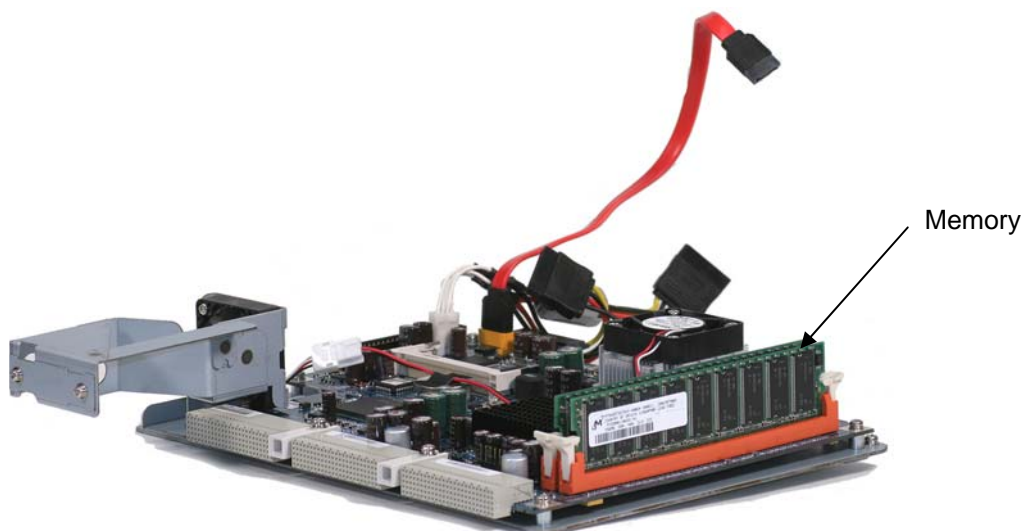

Figure 7-10. Adding/Replacing Memory

5. Lock both socket levers into place to secure the new memory.
6. If this is an upgrade, attach the upgrade label that comes with the upgrade kit on the back of the unit near the serial number.
7. Replace the motherboard as described in section 7.3.1, steps 7-13.

7.3.6. Replacing the Hard Drive



Caution: Be sure to observe all ESD precautions and power off procedures.

To replace the hard drive:

1. Remove the AC cord from the back of the terminal.
2. Remove the chassis top cover and pc shield. (See section 7.3.1 and Figure 7-1.)
3. Unplug the data and power cable from the hard drive.
4. Remove the retaining screw.
5. Slide the hard drive bracket up and out of the chassis.
6. Remove the four screws that secure the hard drive to the bracket.
7. Replace the hard drive and secure it to the bracket with the four screws.
8. Slide the hard drive bracket into place in the chassis and seat it securely.
9. Secure it with the retaining screw.
10. Connect the two cables.
11. Replace the pc shield and chassis top cover.

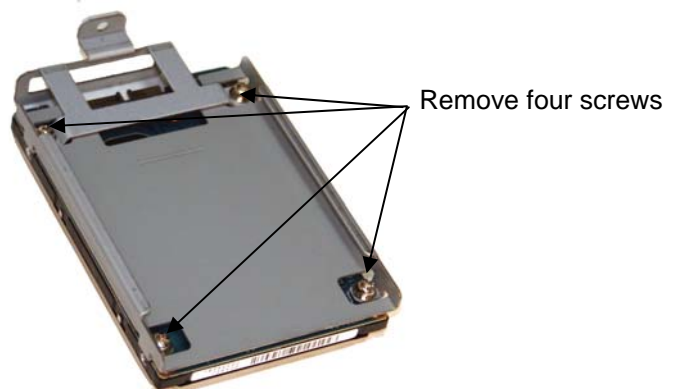
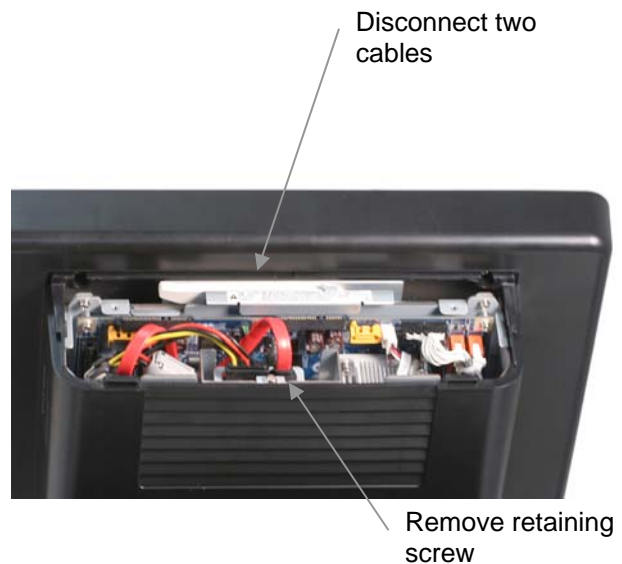

7.3.7. Replacing the Power Supply

To replace the power supply:

1. Remove the AC cord from the back of the terminal.

Slide back cover up to remove it

2. Remove the back cover by sliding it up.



3. Remove the two screws that secure the power supply cover. Pull the cover up to remove it.

Remove two screws

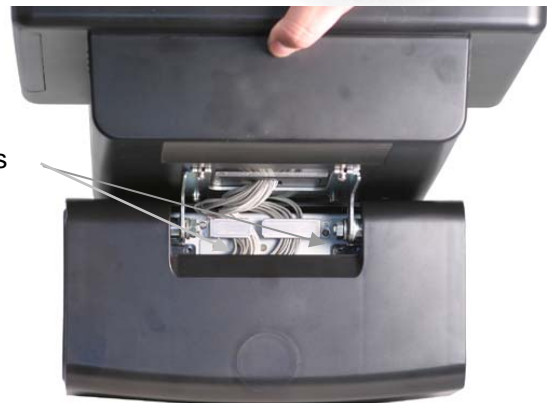

4. Remove the three screws that retain the back panel. Remove the screws that secure one of the brackets using a Philips head screwdriver. The panel will fold down and the power supply will slide out.

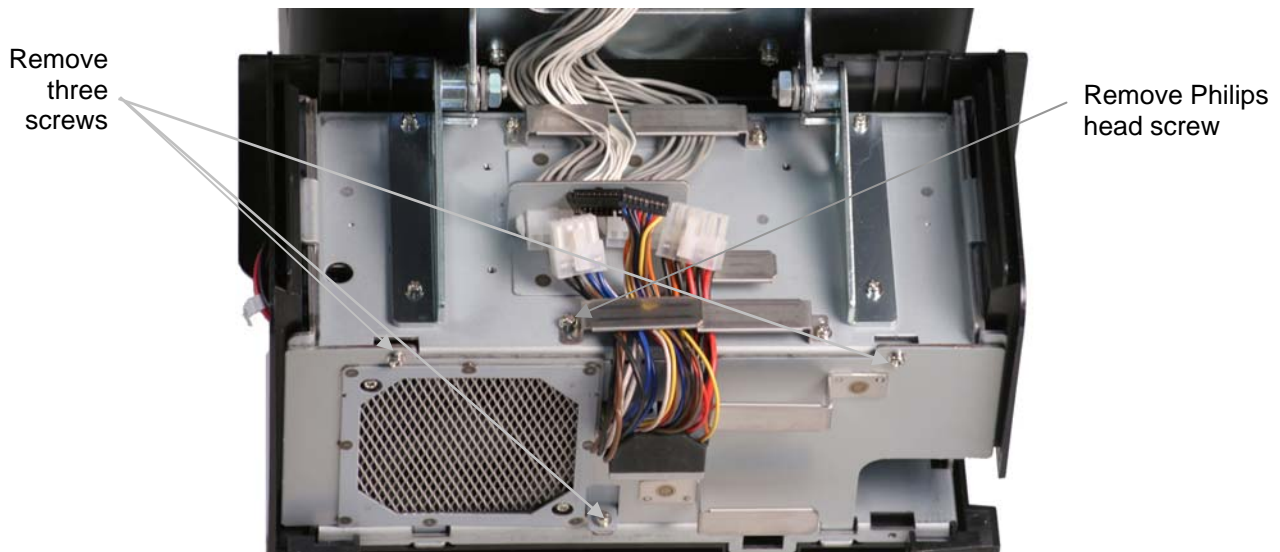

5. Disconnect the power supply cables.
6. Remove the power supply and replace it.
7. Reconnect the cables and route them under the brackets, secure the bracket.
8. Replace the back panel and secure it with the three screws removed in step 4.
9. Replace the power supply back cover.

Note: Earlier models had a battery cable connected to the power supply. This cable needs to be removed before replacing the power supply. This requires removing the side panel and the cable clamp.

7.3.8. I/O Panel

The I/O panel is not field replaceable.

Chapter 8 - Troubleshooting

8.1 Power cannot be turned on or the unit powers off after a few minutes.

The power LED next to the power switch does not light up.

NOTE: Assume Windows operating system and OPOS/JavaPOS.

No	Check item	Judgment	Action
1.	Is the power cable connected?	Y N	Go to No. 2. Connect the power cable.
2.	Is there power to the AC outlet? (Test with device known to work.)	Y N	Go to No.3. Turn on power to the distribution panel.
3.	Does the power shut off after a few minutes?	Y N	Go to No. 4. End.
4.	Go into the BIOS by hitting “F2” during boot up and “Load Optimized Defaults”. Does the power stay on?	Y N	End. Go to No. 5.
5.	Go into the BIOS (“F2”) and go to the “hardware monitoring” section. Are there any warnings or readings close to a warning?	Y N	Correct situation (ex. remount heatsink, clean vents, etc.) – End. Go to No. 6
6.	Check pins on Docking Backplane connectors to insure they are not bent or shorted. Are any pins bent or shorted together?	Y N	Replace barebones whole unit. Go to No.7.
7.	Can the power be turned on after replacing the power supply unit?	Y N	End. Go to No. 8.
8.	Can the power be turned on after replacing the motherboard?	Y N	End. Replace barebones whole unit.



Caution: Before replacing any boards, unplug the power cable and make sure the motherboard standby power LED light is out.

8.2 System will not boot up

(The system fails to start up even though the power is turned on)

No	Check item	Judgment	Action
1	Is data displayed on the monitor during Power On Self Test (POST)?	Y	Go to No.2., or go to LCD troubleshooting section if display goes blank after POST.
		N	Go to LCD troubleshooting section if no display.
2	Is there an error message displayed on the monitor?	Y	See the POST message & act accordingly.
		N	Go to No.3.
3	Does the system get through the POST without hanging up?	Y	Go to No. 7.
		N	Go to No. 4.
4	Replace memory – Does system get through POST?	Y	End.
		N	Go to No. 5.
5	Replace CPU chip – Does system get through POST?	Y	End.
		N	Go to No. 6.
6	Replace motherboard – Does system get through POST?	Y	End.
		N	Go to No. 13.
7	Can BIOS be accessed by hitting F2 during POST?	Y	Load BIOS Defaults/Save & Exit/Go to #8.
		N	Go to No. 12.
8	Has the system(O/S)been installed?	Y	Go to No.9.
		N	Install O/S and reboot.
9	Can the system boot up in “Safe Mode” by hitting F8 during POST?	Y	O/S or driver reload is probably required.
		N	Go to No. 10.
10	Is the HDD cable connected?	Y	Go to No.11.
		N	Connect the cable.
11	Can the system boot up from a bootable USB key or bootable CD by changing the BIOS to boot from that device first?	Y	Reload O/S and reboot – If unable to load O/S go to No. 13.
		N	Go to No. 12.
12	Can the system be started after replacing the motherboard?	Y	End.
		N	Go to No.13.
13	Can the system be started after replacing the HDD and reloading the O/S?	Y	End.
		N	Go to No.14.
14	Can the system be started after replacing the power supply?	Y	End.
		N	Change the whole unit.

8.3 Display/LCD shows correctly during Power On Self Test (POST), but fails when the Operating System (OS) starts

No	Check item	Judgment	Action
1	Does the display show properly if terminal is booted up in "Safe Mode" (F8 pressed during POST) (Windows Only)	Y	Display drivers wrong or not installed properly – Go to Device Mgr and update all display adapters while in safe mode by right clicking on each driver and updating to the correct driver, if failure still occurs O/S could be corrupted – reload.
		N	Go to No. 2
2	Does the display go blank at different times when the OS is running?	Y	Go to No 5
		N	Go to No. 3
3	Does the display work properly if terminal is booted up from another device? (ex. USB key, CD, floppy)	Y	Operating System could be corrupted on hard drive or hard drive is bad. Reseat hard disk and reboot. If failure still occurs reload software or remove and replace HDD.
		N	Go to No. 4
4	Go into the BIOS by hitting F2 during POST, and "Load Optimized Defaults". Does the display work properly?	Y	End
		N	Go to No 5
5	Check JP-1 on the motherboard. Is the jumper set to 2-3 (LVSD)?	Y	Go to No. 6
		N	Set jumper to 2-3. End.
6	Does the display work properly after replacing the motherboard?	Y	End.
		N	Go to No. 7
7	Does the display work after replacing the power supply?	Y	End.
		N	Change the whole unit.

8.4 Display/LCD is blank at all times

No	Check item	Judgment	Action
1	Is there power to the terminal and other peripherals?	Y N	Go to No. 2. Go to the Power Cannot Be Turned On in troubleshooting section.
2	Is display correct after adjusting brightness/contrast on the LCD?	Y N	End. Go to No. 3.
3	Does the display function after replacing the motherboard?	Y N	End. Go to No. 4.
4	Are there any loose connections between the power supply and the unit?	Y N	Secure connections. Replace bare bones unit.



Caution: Before replacing any boards, unplug the power cable and make sure the motherboard standby power LED light is out.

8.5 Deletion of date, time and disk setup data when turning off power

No	Check item	Judgment	Action
1	Is the voltage of the lithium battery on the motherboard normal?	Y	Go to No.2.
		N	Change the motherboard.
2	Is the "Clear CMOS" jumper on the motherboard set to "normal" (jumper between pins 2-3)	Y	Go to No. 3.
		N	Set jumper correctly.
2	Is operation executed normally after replacing the motherboard?	Y	End.
		N	Change the whole unit.

8.6 MSR reading error

Note: the MSR is an optional peripheral.

No	Check item	Judgment	Action
1	Is the MSR cable connected correctly?	Y	Go to No.2.
		N	Connect the cable correctly.
2	Does the magnetic card meet ISO standards?	Y	Go to No.3.
		N	Try a known good card and go to No. 3 if good card still fails.
3	Was the card swiped in the correct direction?	Y	Go to No.4.
		N	Change the position.
4	Can it read correctly after cleaning the MSR with a cleaning card?	Y	End.
		N	Go to No.5.
5	Does the MSR operate properly using the test program?	Y	Check OPOS/JavaPOS drivers.
		N	Go to No. 6.
6	Is data read normally after replacing the MSR?	Y	End.
		N	Go to No. 7.
7	Does the MSR work after replacing the motherboard?	Y	End.
		N	Change the whole unit.



Caution: Before replacing any boards, unplug the power cable and make sure the motherboard standby power LED light is out.

8.7 Customer display errors

Note: the customer display is an optional peripheral device.

No	Check item	Judgment	Action
1	Is the cable connected correctly?	Y N	Go to No.2. Connect the cable correctly.
2	When you turn on the power, is the VFD version displayed? EX:[V01.00.05 FJ i] *	Y N	Go to No. 3. Go to No. 4.
3	Will WINCLD run normally using the VFD test program?	Y N	Possible software problem, check OPOS/JAVAPOS. Go to No. 4.
4	Will the display show properly after replacing the display cable?	Y N	End. Go to 5.
6	Does the VFD run properly after replacing the power supply?	Y N	End. Change the whole unit.



Caution: Before replacing any boards, unplug the power cable and make sure the motherboard standby power LED light is out.

8.8 Operation errors of other peripheral devices

No	Check item	Judgment	Action
1	Is the cable connected correctly?	Y N	Go to No. 2. Connect the cable correctly.
2	Does WINCLD operate properly with this peripheral?	Y N	Check the program. Go to No. 3.
3	Can the system be activated after replacing the motherboard ?	Y N	End. Go to No. 4.
4	Can the system be activated after replacing the power supply?	Y N	End Change the controller.



Caution: Before replacing any boards, unplug the power cable and make sure the motherboard standby power LED light is out.

This page intentionally blank.

Chapter 9 - BIOS

The following BIOS set-up instructions and settings are for BIOS level P09 on the original release of the TeamPoS 3000XT terminal. The BIOS level is expected to change throughout the life of the terminal and therefore these readings may not necessarily reflect later versions of the BIOS. The latest BIOS version can be obtained from Fujitsu's FTP site at [ftp://ftp.ftxs.fujitsu.com/POS/POSsustaining/Retail/TeamPOS 3000XT](ftp://ftp.ftxs.fujitsu.com/POS/POSsustaining/Retail/TeamPOS%203000XT). Note: a user name and password is required to access the FTP site. Please see your technical support for access information.

If access to the ftp site is not possible, the latest BIOS should be available on <http://www.fujitsu.com/us/services/retailing/support/drivers/index.html> in the near future.

If a motherboard is replaced in the field, it may be necessary to change the date and time and set up the BIOS for the customer's configuration. The following information shows the default screens from the factory.

Opening CMOS Setup Screen

Turn ON power and press the "F2" key while the terminal goes through the power on self test.(POST). (It will be necessary to attach an external keyboard to do this.)

CMOS Settings

If a new motherboard has been installed, it will be necessary to set the date and time before releasing the terminal to the customer. To change the date and time, select STANDARD CMOS FEATURES and manually make changes by inserting the current date and time. Run "LOAD OPTIMIZED DEFAULTS" then "SAVE & EXIT SETUP." Other default settings may be changed at this time if the customer requires settings other than the default settings listed here. Changing other default settings can adversely effect the operation of the unit.

In most cases, the CMOS default settings are adequate and do not require changing. Follow the instructions on the screen to select STANDARD CMOS SETUP. To change the time and date follow, the instructions on the screen. Run LOAD OPTIMAL DEFAULTS located under the "EXIT" tab. Exit, saving settings.

Note: The arrow [▶] indicates additional screens. Use [Enter] to advance to the next screen. Text shown in blue is either dynamic, meaning it changes as the unit operates, or it is set for automatic mode and is not selectable in that mode.

Instructions or information on how to change settings appear in the right column under "Item Help." Information appropriate to the item selected appears under "Menu Level."

9.6 Advanced Chipset Features

Phoenix – AwardBIOS CMOS Setup Utility Advanced Chipset Features		
DRAM Timing Selectable [By SPD] x CAS Latency Time 2.5 x Active to Precharge Delay 7 x DRAM RAS# to CAS# Delay 3 x DRAM RAS# Precharge 3 DRAM Data Integrity Mode [ECC] MGM Core Frequency [Auto Max 400/333MHz] System BIOS Cacheable [Enabled] Video BIOS Cacheable [Enabled] Memory Hole At 15M-16M [Disabled] AGP Aperture Size (MB) [64] xx On-Chip VGA Setting xx On-Chip VGA [Enabled] On-Chip Frame Buffer Size [32MB] Boot Display [VBIOS DEFAULT] ICD-Device 2. Function 1 [Enabled] Panel Scaling [Auto]	Item Help	
		Menu Level ▶ <i>Information or instructions will appear here for each selection.</i>
↑ ↓ → ← : Move Enter : Select +/-/PU/PD : Value F10 : Save ESC : Exit F1: General Help F5: Previous Values F7: Optimized Defaults		

9.7 Integrated Peripherals

Phoenix – AwardBIOS CMOS Setup Utility Integrated Peripherals		
▶ USB Configuration [Press Enter] ▶ OnChip IDE Device [Press Enter] ▶ Onboard Device [Press Enter] ▶ Super I/O Device [Press Enter]	Item Help	
		Menu Level ▶ <i>Information or instructions will appear here for each selection.</i>
↑ ↓ → ← : Move Enter : Select +/-/PU/PD : Value F10 : Save ESC : Exit F1: General Help F5: Previous Values F7: Optimized Defaults		

9.12 Power Management Setup

Phoenix – AwardBIOS CMOS Setup Utility Power Management Setup		
ACPI Function	[Enabled]	Item Help
ACPI Suspend Type	[S1&S3]	
Run VGABIOS if S3 Resume	[Auto]	Menu Level ▶
Power Management	[User Define]	<i>Information or instructions will appear here for each selection.</i>
Video Off Method	[DPMS]	
Video Off In Suspend	[Yes]	
Suspend Type	[Stop Grant]	
MODEM Use IRQ	[3]	
Suspend Mode	[Disabled]	
HDD Power Down	[Disabled]	
Soft-Off by PWR-BTTN	[Delay 4 Sec.]	
Wake-Up by PCI Card	[Disabled]	
Power On by Ring	[Disabled]	
USB KB Wake-Up From S3	[Disabled]	
Resume by Alarm	[Disabled]	
x Date(of Month) Alarm	0	
x Time(hh:mm:ss) Alarm	0: 0: 0	
PWRON After PWR-Fail	[Former-Sts]	
↑ ↓ → ← : Move Enter : Select +/-/PU/PD : Value F10 : Save ESC : Exit F1: General Help F5: Previous Values F7: Optimized Defaults		

9.13 PnP/PCI Configurations

Phoenix – AwardBIOS CMOS Setup Utility PnP/PCI Configurations			
Clear NVRAM	[No]	Item Help	
PNP OS Installed	[No]		
Reset Configuration Data	[Disabled]	Menu Level ▶	
Resources Controlled By	[Auto(ESC)]	<i>Information or instructions will appear here for each selection.</i>	
x IRQ Resources	Press Enter		
x DMA Resources	Press Enter		
x Memory Resources	Press Enter		
PCI/VGA Palette Snoop	[Disabled]		
Assign IRQ for VGA	[Disabled]		
PCI Latency Timer (CLK)	[64]		
↑ ↓ → ← : Move Enter : Select +/-/PU/PD : Value F10 : Save ESC : Exit F1: General Help F5: Previous Values F7: Optimized Defaults			

Chapter 10 - Spare and Upgrade Parts List

		6500	6501	6510	6521	6531
CABLES						
CABLE(12LCD)	KD02906-0831	1	1			
CABLE(15LCD)	KD02906-0841			1	1	1
CABLE(BATT)	KD02906-1701	1	1	1	1	1
CABLE(DKG-I/F)	KD02906-0821	1	1	1	1	1
CABLE(EX-PSU)	KD02906-0851	1	1	1	1	1
CABLE(OP1)	KD02906-0801	1	1	1	1	1
CABLE(OP2)	KD02906-0811	1	1	1	1	1
LABELS						
PL LABEL	KD91313-0842	1	1	1	1	1
B/B LABEL	KD91314-085X	1	1	1	1	1

FRAME AND COVERS						
PC FRAME ASY	KD30277-E730	1	1	1	1	1
HDD COVER ASY	KD30277-E731	1	1	1	1	1
FG FRAME ASY	KD30277-E736	1	1	1	1	1
PC SHIELD ASY	KD30277-E739	1	1	1	1	1
CN PANEL ASY	KD30277-E743	1	1	1	1	1
STAND FRAME ASY	KD30277-E775	1	1	1	1	1
PSU METAL ASY	KD30277-E782	1	1	1	1	1
STAND BASE	KD30277-Y781	1	1	1	1	1
CN BRACKET	KD30277-Y785	1	1	1	1	1
CABLE HOLDER A	KD30277-Y786	2	2	2	2	2
CN PLATE	KD30277-Y787	1	1	1	1	1
CABLE HOLDER B	KD30277-Y792	3	3	3	3	3
METAL-A	KD30277-Y794	1	1	1	1	1
BP GUIDE ROD	KD30277-Y017	2	2	2	2	2
REAR COVER 12	KD30277-Y710	1	1			
REAR COVER 15	KD30277-Y711			1	1	1
TOP COVER	KD30277-Y712	1	1	1	1	1
CN FRONT COVER	KD30277-Y713	1	1	1	1	1
CN RRAR COVER	KD30277-Y714	1	1	1	1	1

FRAME AND COVERS						
PWR COVER	KD30277-Y715	1	1	1	1	1
PWR PANEL	KD30277-Y716	1	1	1	1	1
LENS	KD30277-Y717	1	1	1	1	1
CABLE COVER	KD30277-Y718	1	1	1	1	1
FRONT COVER	KD30277-Y719	1	1			
BOTTOM COVER	KD30277-Y760	1	1	1	1	1
LOW COVER	KD30277-Y761	1	1	1	1	1
TOP COVER	KD30277-Y762	1	1	1	1	1
SIDE COVER	KD30277-Y763	2	2	2	2	2
TILT COVER	KD30277-Y764	1	1	1	1	1
POLE DUMMY	KD30277-Y766	1	1	1	1	1
BATT COVER	KD30277-Y768	1	1	1	1	1
CABLE COVER	KD30277-Y769	1	1	1	1	1
12-DUMMY COVER	KD30277-Z205	1	1			
15-DUMMY COVER	KD30277-Z255			1	1	1

GASKETS AND PACKING						
GASKET	KD30277-Y302	1	1	1	1	1
GASKET	KD30277-Y304	2	2	2	2	2
GASKET	KD30277-Y305	1	1	1	1	1
GASKET	KD30277-Y317	1	1	1	1	1
GASKET	KD30277-Y319	2	2	2	2	2
BP PACKING	KD30277-Y749	1	1	1	1	1
GASKET	KD30277-Y330	1	1	1	1	1
GASKET	KD30277-Y331	1	1	1	1	1
GASKET	KD30277-Y332	1	1	1	1	1
GASKET	KD30277-Y333	2	2	2	2	2
GASKET	KD30277-Y334	1	1	1	1	1
GASKET	KD30277-Y335	1	1	1	1	1
GASKET	KD30277-Y336	2	2	2	2	2
GASKET	KD30277-Y337	2	2	2	2	2

RAILS, CLAMPS, SCREWS						
GUIDE RAIL	L0KD30277-0950	2	2	2	2	2
SLIDE CLAMP	L0KD30277-0951	2	2	2	2	2
SCREW	F6-SSA3-06121	4	4	4	4	4
SCREW	F6-SW2N3-05121	3	3	3	3	3
SCREW	F6-SW2N3-06121	30	30	30	30	30
SCREW	F6-SW2N3-08121	8	8	8	8	8
SCREW	F6-SW2N3-10121	4	4	4	4	4
SCREW	F6-SW2N3-14121	2	2	2	2	2
SCREW	F6-SW2N4-10121	8	8	8	8	8
LOCK SCREW	LOCA52223-1014	6	6	6	6	6

LCDS						
12LCD SET	L0KD02907-6600	1				
12LCD SET	L0KD02907-6601		1			
15LCD SET	L0KD02907-6610			1		
15LCD SET	L0KD02907-6621				1	
15LCD SET	L0KD02907-6631					1

POWER SUPPLY						
PSU	KD02906-1100	1	1	1	1	1

MISC 1						
AOK05AA	KD20052-B40X	1	1	1	1	1
ALK05AA	KD20055-B01X	1	1	1	1	1
DOCKING BOARD	KD02906-1043	1	1	1	1	1

MISC 2						
CEILING CUSHION	KD30277-Y758	1	1			
CUSHION	KD32001-Y676	2	2	2	2	2
NET A	KD30277-Y751	3	3	3	3	3
NET B	KD30277-Y752	1	1	1	1	1
HINGE	L0KD30277-0911	1	1	1	1	1
CABLE CLAMP	L0KD30277-0953	3	3	3	3	3
CYLINDER LOCK	L0KD30277-0952	1	1	1	1	1
FOOT RUBBER	KD30277-Y671	4	4	4	4	4
ACETATE TAPE	CT-570F- TERAOKA	*	*	*	*	*
Tool	KD30277-Y759	1	1	1	1	1

Motherboard			
OPN TP3K Motherboard/SHE	KD02906-1011	11000021	Includes plate

CPU Options			
OPN TP3K CPU/1.3 Celeron M		11000027	
CPU, Intel, Celeron M, 1.3 GHz		11000240	Same as 90000962
OPN TP3K CPU/1.5 Celeron M		11000028	
CPU, Intel, Celeron M, 1.5 GHz		11000234	
OPN TP3K CPU/1.6 Pentium M		11000029	
CPU, Intel, Pentium M, 1.6 GHz		11000239	Same as 90000833
OPN TP3K CPU/2.0 Pentium M		11000241	
CPU, Intel, Pentium M, 2.0 GHz		11000242	
HEATSINK – Socket 479	CA49007-7057	11000235	

Memory Options			
OPN TP3K Memory/DDR/256MB		11000022	Same as 90000784
OPN TP3K Memory/DDR/512MB		11000023	Same as 90000785
OPN TP3K Memory/DDR/1GB		11000024	Same as 90000786
OPN TP3K Memory/DDR/2G		11000095	1G x 2

Hard Disk Options			
OPN TP3K HDD ASSY/2.5"/40GB	N/A	11000030	
HDD/2.5"/40GB	KD02906-5700	11000243	
TP3K 2.5" HDD Bracket	KD30277-Y048	11000278	
Screw	F6-SW2N3-05121	11000594	
Plastic Pull Tab	KD30277-Y096	11000732	

