

U-Scan Max Single Station - BANNER Arch Sensor Service Information

The adjustment mechanism for the BANNER arch sensor has changed in newer U-Scan Max Single Station casings. The sticks can now be raised and lowered, pivoted left and right, and pivoted front and back within the sensor housing. Follow the steps below to adjust the BANNER arch sensor on site.

Requirements:

- Phillips screwdriver (magnetic tip recommended)
- Two test shims (9000100 and 9000101 - Engineering drawings included at end of document)
- 11-32 wrench
- 11-32 nut driver

Adjustment Guide:

Shim(s)	Size	Result
9000100 (thinner)	.115 to .122	No Detect
9000101 (thicker)	.175 to .182	Detect preferable, but not essential
9000100 + 9000101 (stacked one on top of each other)	.290 to .304	Must detect

LED Indications

The BANNER sensor array consists of a sensor and an emitter detection stick.

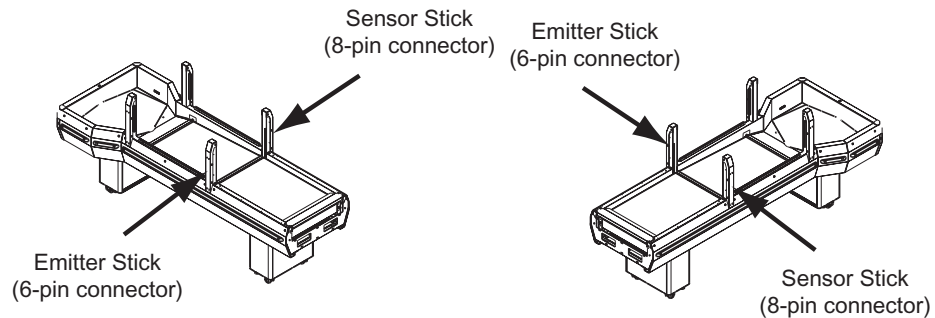

The sensor stick includes three colored indicator LEDs. Refer to the table below for LED indications.

Detection Stick	LED	Function
Emitter	Red	Power on, operation OK
Sensor	Red	Object detected
Sensor	Yellow	<ul style="list-style-type: none">• Sensor not properly aligned• Lens may be dirty• Device may be faulty
Sensor	Green	Alignment of sensor is correct, ready for operation

Overview of Adjustment Hardware

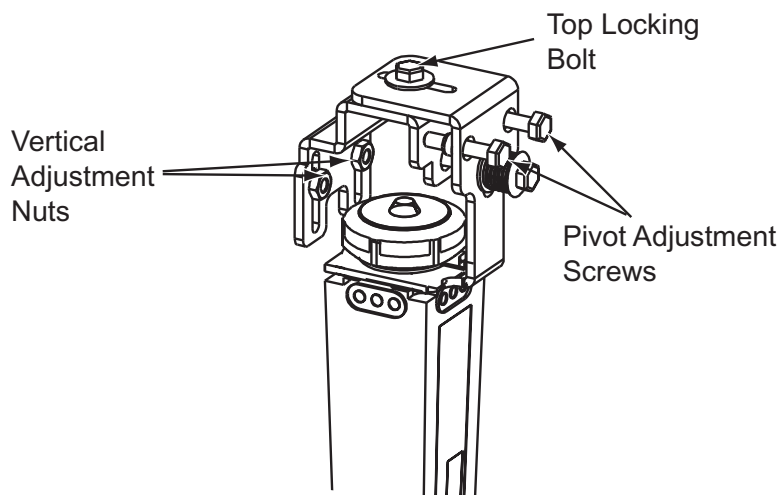

Vertical Adjustment

1. Access the adjustment mechanism inside the arm:
 - a. Remove the Plexiglas guards.
 - b. Remove the metal sensor faceplates on the arch housings.

NOTE: *Future casing models may have a pivoting bracket installed on the top portion of the arch housings. Remove the screw securing the bracket and pivot it down to access the adjustment mechanism. There is no need to remove the Plexiglas guards and faceplate on these casings.*

2. Use an 11-32 wrench to **slightly** loosen the top locking bolt.

-
3. Test the thinner shim (9000100) in the following locations while the belt is running. Ensure that the shim is **not** detected. The sensor stick green LED should be on.
 - a. Center of the belt
 - b. 9” to the left of center
 - c. 9” to the right of center
 4. If necessary, loosen the two 8-32 vertical adjustment nuts on the back brackets and raise both sticks until the shim is not detected.
 5. Test the thicker shim (9000101) in the same three locations while the belt is running. This shim represents the tolerance threshold: it is preferable but not essential that the sensor detects this shim.
 6. Test both shims stacked one on top of each other in the three positions while the belt is running. Ensure that the shims **are** detected. The sensor stick red LED should come on when the shims pass through the arch.
 7. If necessary, lower the sticks until the shims are detected.
 8. If the sensors are properly aligned, tighten the top locking bolt.

OR

If the sensors are still not aligned, try pivoting the sensor sticks forward/backward OR left/right in the sensor housing as outlined below.

Pivoting the Detection Sticks (Forward/Backward, Left/Right)

If you determine that the vertical position of the detection sticks is correct but there is still an issue with the arch alignment, follow the steps below to pivot the detection sticks in the housing.

1. The detection sticks must be perfectly parallel to each other. Follow the steps below to pivot the detection sticks forward or backward in the sensor housing:
 - a. Locate the two pivot adjustment screws on the front bracket.
 - b. Tighten both screws to pivot the front of the stick forward OR loosen both screws to pivot the front of the stick back.

NOTE: *Alternate between turning the adjustment screws. For example, turn the left screw two times, then turn the right screw two times until the desired position is achieved.*

 - c. Ensure that no object is detected when nothing is present between the sensors.
 - d. Ensure that the sensor detects both shims stacked one on top of each other.
 - e. **Tighten the top locking bolt when the sensor is properly aligned.**
2. The sensor beams must point directly straight ahead. The emitter stick beam should align with the center of the sensor stick. Follow the steps below to pivot the emitter stick to the left or right.

-
- a. Locate the two pivot adjustment screws on the front bracket. (They are the same screws used to pivot the sticks forward and backward.)
 - b. Tighten the right adjustment screw to turn the stick slightly clockwise, OR tighten the left adjustment screw to the turn the stick slightly counterclockwise.
 - c. Ensure that no object is detected when none is present between the sensors.
 - d. Ensure that the sensor detects both shims stacked one on top of each other.
 - e. **Tighten the top locking bolt when the sensor is properly aligned.**

