

Subject: U-Scan Belt Collection Area Roller Tray

Overview

A new option is now being offered to customer that use the U-Scan Single Belted Unit (SBU) system, a Roller Collection Area Tray. This Roller Tray allows products to exit the belt and transition to the end of the collection area quicker and more dispersed across the collection area rather than stacked in the center.

This feature is NOT RoHS complaint and is only offered in North America at this time.

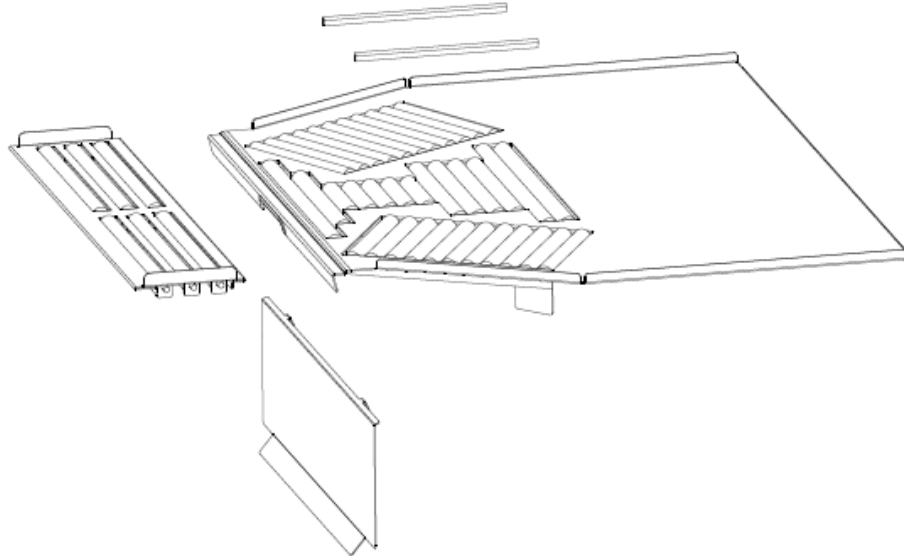

Kits and Parts

The following kit is now available with new SBU orders or as a field installable upgrade option to existing units.
CNV-1002S410 Complete Roller Plate Kit

This kit consists of the following assemblies:

- CNV-1002S400 Collection Area Roller Insert
- CNV-1002S405 Diverter Plate
- CNV-1002S402 End-Access Plate with Rollers

For service, the rollers can be removed individually by pressing in on one of the end support pins.

90001560	Roller, 20mm, 12.00" Length	3 per Lane
90001564	Roller, 20mm, 10.00" Length	6 per Lane
90001561	Roller, 20mm, 8.00" Length	22 per Lane
90001562	Roller, 20mm, 6.00" Length	5 per Lane
90001563	Roller, 20mm, 4.00" Length	5 per Lane

INQUIRIES TO:		DATE
Fujitsu Transaction Solutions Inc.		
Exchange:	Sustaining Engineering	Sustaining Engineering
Mail:	Fujitsu USA04, Sustaining Engineering	
FAX:	858-731-4781 (7888-4781)	Product Manager
Internet:	SustainingEngineering@ftxs.fujitsu.com	
FTP:	ftp://ftp.ftxs.fujitsu.com/	Author
Original signature copies maintained by Sustaining Engineering.		

Installation Instructions

1. Remove existing Insert and Access Tray.
2. If necessary and damaged, replace rubber strip on either side of Collection area.

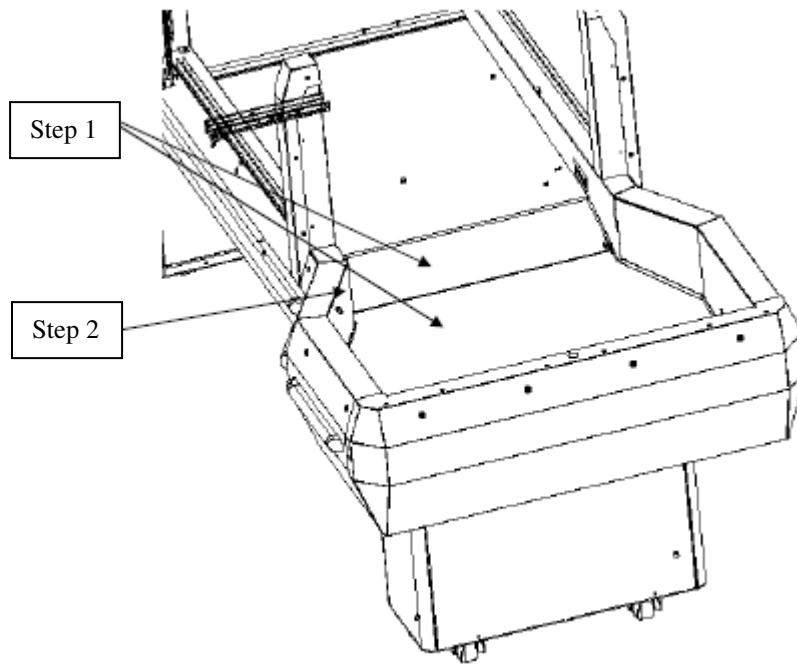

3. Install Diverter Plate first. This drops in between the Rear Takeaway Belt and Collection area. Align the tabs with slots.
 4. Drop in the Roller Insert within the Collection area.
 5. Drop in the Access Tray.
- COMPLETED

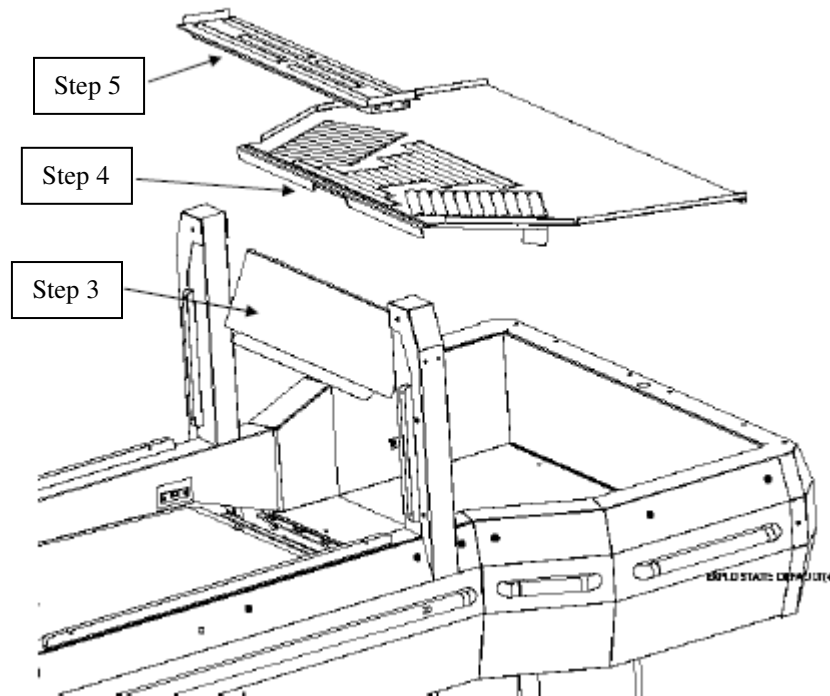

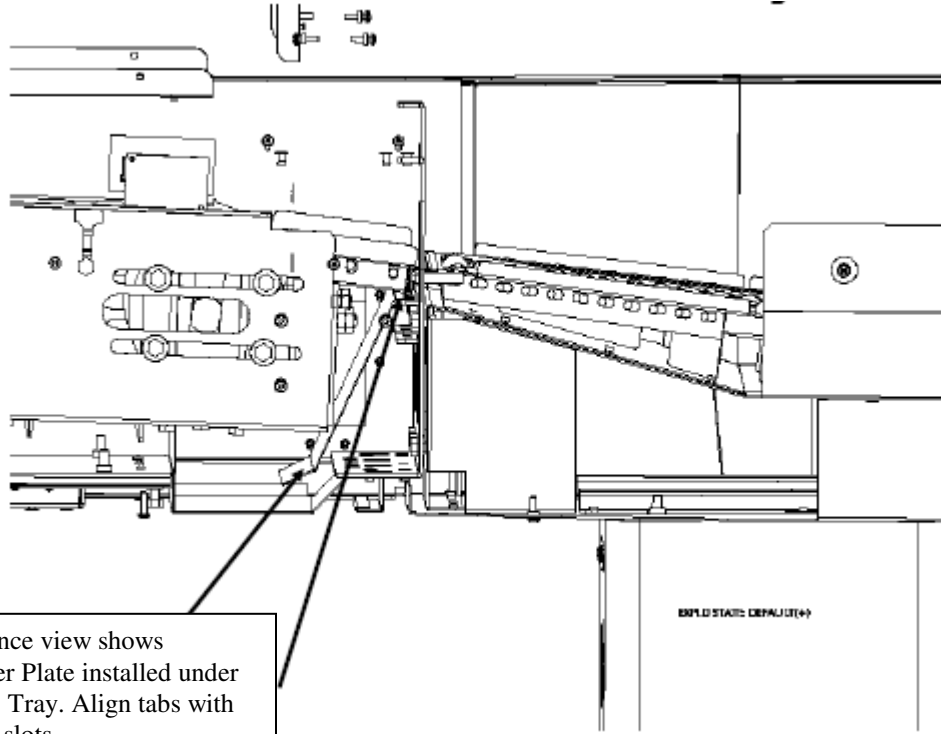

Reference view shows
Diverter Plate installed under
Access Tray. Align tabs with
visible slots.