



Subject: TeamPoS 3000 XE Hardware Platform



INQUIRIES TO:

Fujitsu Transaction Solutions Inc.
Exchange: Sustaining Engineering
Mail: Fujitsu USA04, Sustaining Engineering
FAX: 858-731-4781 (7888-4781)
Internet: SustainingEngineering@ftxs.fujitsu.com
FTP: <ftp://ftp.ftxs.fujitsu.com/>

DATE

Sustaining Engineering

Product Manager

Author

Original signature copies maintained by Sustaining Engineering.

	Fujitsu Transaction Solutions	SUPPORT PLANNING GUIDE TeamPos 3000XE	SPG-06-003
	Sustaining Engineering		Issue: 1.0
	San Diego, CA; Montreal , QC		January 4, 2007

SYNOPSIS

This document is intended to supply sufficient information to North American service planners to enable them to plan for the introduction of the above product(s).

This SPG is the generic version, released by the product authority, Fujitsu Transaction Solutions (FTXS), Sustaining Engineering. Each group releasing the product will use the information contained as the basis for their Logistics and Field Service planning activities.

This document details only the corporate philosophies, and does not seek to cover such subjects as additional services offered by Managed Services, third party service providers, low level repairs, or the local sourcing of components and consumable items.

The service descriptions in this document are guidelines, detailing the recommendations of the product authority. The information within this document has been reviewed for accuracy, but as with most documents, errors may be found and corrected in future revisions. Fujitsu Transaction Solutions (FTXS) cannot be held liable for any inaccurate information found in this document.

0. DOCUMENT CONTROL	5
0.1. ISSUE LEVEL.....	5
0.2. CHANGES FROM PREVIOUS ISSUE	5
0.3. TERMS AND ABBREVIATIONS.....	5
0.4. REFERENCE DOCUMENTS	5
1. OVERVIEW.....	6
1.1. RELEASE SCHEDULE	6
1.2. PRODUCT DESCRIPTION	6
1.3. SOFTWARE.....	7
1.3.1. OPERATING SYSTEMS.....	7
1.3.2. APPLICATIONS.....	7
1.4. HARDWARE.....	7
1.4.1. MOTHER BOARD:	8
1.4.2. I/O Back Panel Ports	9
1.4.3. I/O Option Boards.....	10
1.4.4. Front Operator Panel	11
1.4.5. Power Supply Unit (PSU)	12
1.4.6. Disk Drive	12
1.4.7. CD-ROM.....	12
1.5. SPECIFICATIONS.....	13
1.5.1. Controller Specifications	13
1.5.2. Power Supply	14
1.5.3. Temperature & Humidity	14
1.5.4. Shock & Vibration.....	14
1.5.5. Environmental.....	14
1.5.6. Safety & Regulatory	14
1.6. PERIPHERALS	14
1.6.1. RELIABILITY.....	15
1.6.2. LIFE EXPECTANCY.....	15
2. RESOURCES.....	16
2.1. SKILLS REQUIRED.....	16
2.2. TRAINING	16
2.3. TECHNICAL PUBLICATIONS	16
2.4. SPARES	17
2.5. REPAIR	17
2.5.1. FIELD REPAIR TIME.....	17
2.5.2. DIAGNOSTICS	18
2.5.3. SERVICE TOOLS.....	18
2.5.4. REPAIR TOOLS.....	18
3. SERVICE PROFILES	19
3.1. PREVENTATIVE MAINTENANCE.....	19
3.2. CORRECTIVE MAINTENANCE	19
3.3. ESCALATION PROCEDURES	19

	Fujitsu Transaction Solutions	SUPPORT PLANNING GUIDE TeamPos 3000XE	SPG-06-003
	Sustaining Engineering		Issue: 1.0
	San Diego, CA; Montreal , QC		January 4, 2007

4. APPENDIX A: FAILURE PER YEAR WORKSHEET 20

5. APPENDIX B: MOTHERBOARD..... 21

6. APPENDIX C: BIOS SETUP PROCEDURES 22

7. APPENDIX D: I/O BOARD CONNECTOR PINOUTS AND JUMPERS 34

8. APPENDIX E: ORDERABLE CONFIGURATIONS..... 37

9. APPENDIX F: SPARES PARTS LIST 38

	Fujitsu Transaction Solutions	SUPPORT PLANNING GUIDE TeamPos 3000XE	SPG-06-003
	Sustaining Engineering		Issue: 1.0
	San Diego, CA; Montreal , QC		January 4, 2007

0. DOCUMENT CONTROL

0.1. ISSUE LEVEL

This is the first issue of this document, introducing the TeamPoS 3000 Series hardware platform into the Fujitsu Retail product line.

0.2. CHANGES FROM PREVIOUS ISSUE

None – This is the first issue

0.3. TERMS AND ABBREVIATIONS

AFR	Annualized Failure Rate
CLD	Confidence Level Diagnostic Software
EMI	Electromagnetic Interference
ESD	Electrostatic Discharge
FDD	Floppy Disk Drive
FRU	Field Replaceable Units
FPY	Failures Per Year
HDD	Hard Disk Drive
MSR	Magnetic Strip Reader
MTBF	Mean Time Between Failures
MTTR	Mean Time To Repair
POH	Power On Hours
PSU	Power Supply Unit
SPG	Support Planning Guide
UPC	Universal Product Code (Bar Code)
VFD	Vacuum Florescent Display

0.4. REFERENCE DOCUMENTS

- ❖ Product Announcement
- ❖ Product Requirements Document
- ❖ Product Specification Document
- ❖ Installation and Maintenance Manual
- ❖ SPG TP3K XL (#SPG-06-002)

1. OVERVIEW

The TeamPos 3000 terminal is the next generation of the TeamPos 2000 terminal. There will be a total of three new models introduced.

- TeamPoS 3000XL (High-end PoS) Ref# SPG-06-002
- TeamPoS 3000XT (All-in-One PoS)
- TeamPoS 3000XE (Entry Level PoS)**

1.1. RELEASE SCHEDULE

Product Description	Release Date
Chassis	Jan-Feb 2007
Low Cost (XE) Controller Chassis	
TeamPoS 3000 XE Components	
Motherboard SLC	Apr 2006
CPU, Intel Celeron D 2.93 Ghz	
Power Supply (PSU) 300 Watts	
Serial ATA Hard Disk Drive, 2.5" 80GB	
DDR Memory- 256M, 512M, 1GB,2GB	Apr 2006
Control Panel	

1.2. PRODUCT DESCRIPTION

The TeamPoS 3000 XE is a state-of-the-art Point-of-Sale (PoS) terminal. Built on an industry standard platform, the TeamPoS 3000 XE leverages Intel embedded components and standard operating systems, software applications and peripherals. It supports standard PC components such as a high-performance CPU, memory, hard disk, video and audio. It can be used as a PC, to run standard PC applications, such as word processing, spreadsheets, etc., subject to operating system and licensing restrictions. This controller includes a 2.5" hard disk drive, on board LAN, 12.1 or 15" LCDs; USB, Combo board and a choice of operating systems. Memory capacity, the number of powered RS232 and USB ports are also user-selectable.

The TeamPoS 3000 XE also contains functionality required by retail application software and is "retail hardened" to support the harsh environments found in most retail stores. A variety of possible configurations supports your application requirements.

	Fujitsu Transaction Solutions	SUPPORT PLANNING GUIDE TeamPos 3000XE	SPG-06-003
	Sustaining Engineering		Issue: 1.0
	San Diego, CA; Montreal , QC		January 4, 2007

1.3. SOFTWARE

The TeamPoS 3000 XE control unit has been validated on Windows 2000, Windows XP, Windows XPe, Windows XP Pro, and WEPOS operating systems. Other operation systems may be certified in the future depending upon demand and business case.

Because there are several software options, none are standard with TeamPoS 3000 XE. Other software components such as, device drivers and applications are configuration and customer specific. Also available is a Confidence Level Diagnostics programs.

1.3.1. OPERATING SYSTEMS

Windows 2000
Windows XP
Windows Embedded for Point Of Sale (WEPOS)
Suse Linux

1.3.2. APPLICATIONS

Reference- SPG TeamPOS 3000 XL (#SPG-06-002).

1.4. HARDWARE

The major components of the TeamPoS 3000 XE control unit are:

- PC Motherboard with on board LAN and video
- I/O Option Boards
- Operation Panel Board
- Power Supply Unit (PSU)
- Hard Drive
- Optional CD-ROM (Read Only), or CD-RW/DVD

1.4.1. MOTHER BOARD:

Core chipset:
GA-81865GME-775 Mother Board w/ AWARD BIOS Chip Set
 Intel Processor Celeron D 2.93 GHz
 DDR Memory 256,512,1GB,2GB (Max is 2GB)
 Integrated Video
 Integrated Audio
 Onboard 10/100 LAN
 (2) PCI Slots

GA-81865GME-775 Motherboard Layout

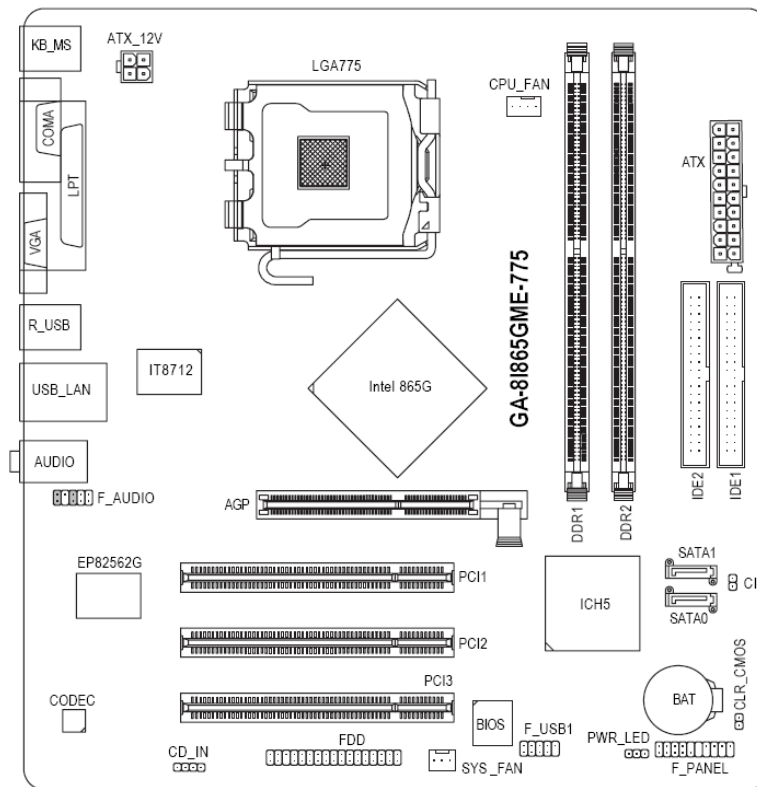

1.4.2. I/O Back Panel Ports

I/O Back Panel Introduction

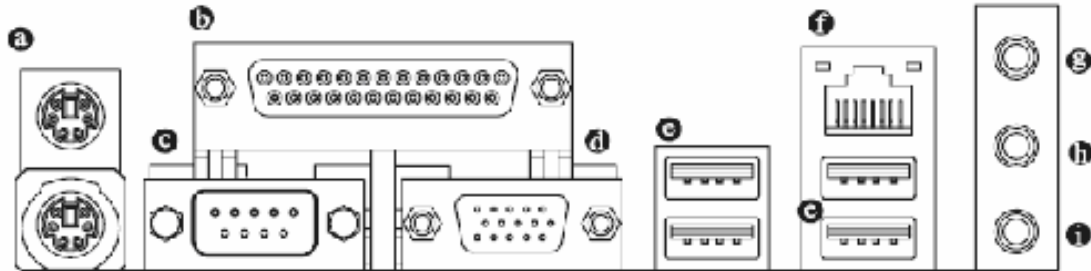

a.	PS/2 Keyboard and PS/2 Mouse Connector
b.	Parallel Port
c.	Serial Port (COM 1)
d.	VGA Port
e.	USB Port(s)
f.	LAN Port
g.	Audio Line In
h.	Audio Line Out
i.	Mic In

1.4.3. I/O Option Boards

There are two different interface boards available on the XE model. The picture below shows the rear of the terminal with **Option I: Powered USB I/O board** 1 x 24 VDC retail powered USB 4 x 12 VDC retail powered USB(USB 2.0) interface card installed.

Powered USB I/O Board.
 1 x 24 VDC retail powered USB
 4 x 12 VDC retail powered USB(USB 2.0)

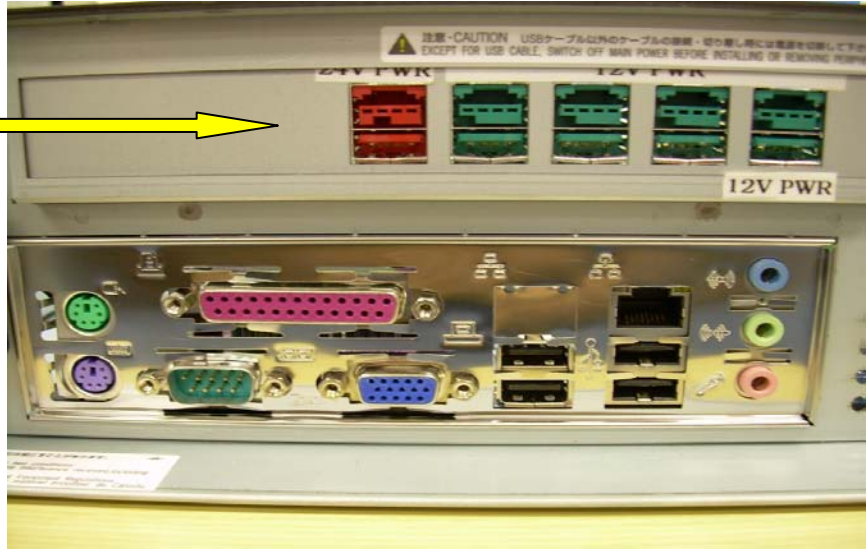

The picture below shows Option 2 **Combo I/O board** 2 x Powered USB, +12 VDC, 1 x Powered RS232 with +24 VDC (15 Pin), 2 x RS232 (DB9), +5 VDC selectable. Comm cards provide support for both USB and legacy devices.

COMBO I/O board.
 2- Powered USB,
 +12 VDC, 1 x
 Powered RS232 with
 +24 VDC (DB15).
 2 x RS232 with +5
 VDC (DB9).

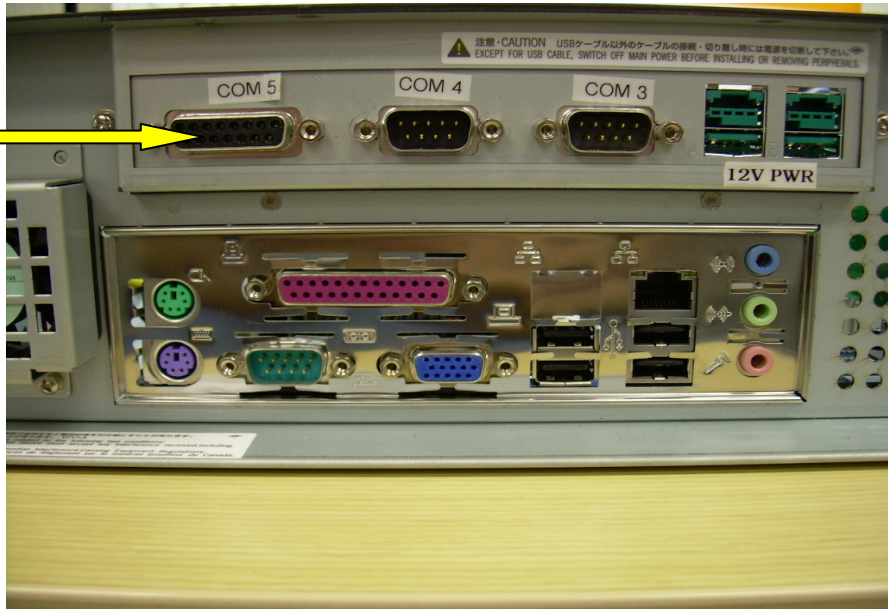

1.4.4. Front Operator Panel

The Operator panel on the TP3000 XE is similar to the panel on the TP2000 terminal except it also includes two 2.0 USB ports. There is a sliding switch on the operation panel that controls the power to the RS232 ports on the option cards. It takes 5 or more seconds before power is removed on the ports once the switch is turned off. It is recommended the switch be used during any RS232 peripheral exchange activity. The switch is “ON” in the right position and “OFF” in the left position. The front two USB ports can be used to boot from USB devices such as a USB key or USB floppy drive.

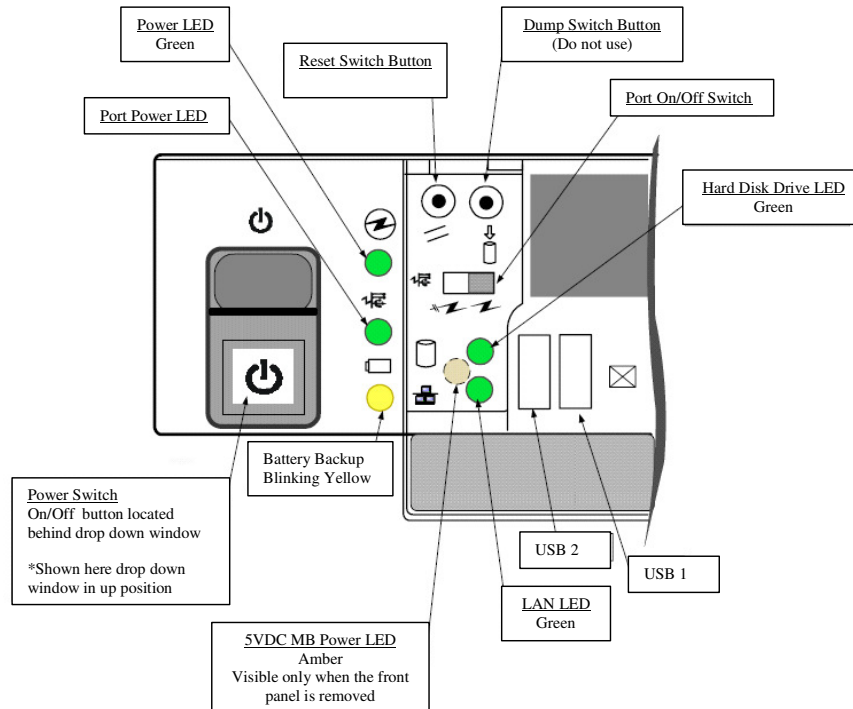

- **RESET SWITCH** – Causes the terminal to do a hard reboot. All data in memory will be lost and terminal will be forced to do a hard reboot.
- **DUMP SWITCH** – Not Used
- **POWER LED** – Indicates AC power is supplied to the power supply and all DC voltages are available to the motherboard and various devices
- **PORT-SW:** Default setting is “ON” (right position). Turns on/off power to RS232 ports.
- **PORT-PWR LED** – Indicates +24 and +5V power is on the printer and RS232 ports. Turning off the port-switch will cause this light to turn off after 5 or more seconds.
- **5VDC MB Power-LED** – Indicates AC power is supplied to the power supply and standby voltages for motherboard are available. Note: Do not remove motherboard from chassis when light is “ON” Unplug AC cord before removing motherboard.
- **HDD-LED** – Hard Disk Drive activity light indicates when the hard drive/s is reading/writing.
- **POWER-SW** – Turns ON/OFF power to terminal. Can be set up in BIOS for soft shutdown (stops Windows in orderly shutdown) after being pressed, or hard shutdown (powers down regardless of activity) after pressing and holding switch for five seconds.
- **BAT-BKUP** – Indicates terminal is running on battery backup when “ON” (Not used in XE model)
- **LAN-LED** – Indicates activity on the LAN when lit
- **USB-IF2 & IF** – USB ports with +5V power supplied when AC power light is “ON”

1.4.5. Power Supply Unit (PSU)

The power supply is internal to the control unit. It provides power to the control unit and peripherals and is located on the backside of the controller. The DC output power is 270 watts maximum for PC board and I/O board functions.

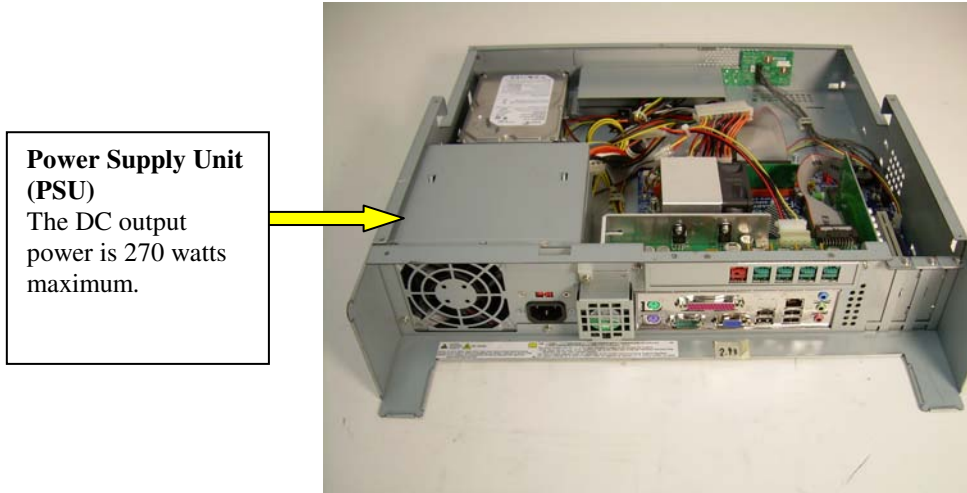

1.4.6. Disk Drive

One IDE or SATA (IDE) hard disk drive can be installed in the TP3000 XE terminal. (See I&M for Hard Disk replacement. Order Part# D900000171).

1.4.7. CD-ROM

There are two types of CD-ROM's available, the standard read-only CD-ROM, and the Read/Write CD/DVD ROM. CD-ROM's can be used for initial program loading and set-up, diagnostics, any other purposes dictated by the application program as well as multi-media applications. (See I&M for CD-ROM replacement. Order Part# D900000171).

1.5. SPECIFICATIONS

1.5.1. Controller Specifications

Features		XE Type	Remark
Mother Board	ISA	No	
	PCI	1 slot (low profile only)	
	AGP	Yes	Not Usable
File Bay	2.5" Bay –1	Primary HDD or Flash Disk	Serial ATA
	5.25" Bay	Slim Line	SlimLineCD-ROM/ComboDrive
Operator Panel & Misc.	Power SW	Yes	
	Reset SW	Yes	
	Dump SW	Disabled	
	COM Port Off SW	Yes	
	HDD select SW	No	Supported by BIOS.
	Power LED	Yes	Green / Amber color LED
	COM Port Power LED	Yes	Yellow color LED
	Battery backup LED	Not Used	Green color LED
	HDD Access LED	Yes	Green color LED
	LAN Activity LED	Yes	Green color LED
	USB Interface LED	No	
	USB Connector	2 ports on Operator Panel	+2 USB Ports on rear
	Speaker	No	Speaker is on LCD
Enclosure	Dimension	17.7''(W)x20''(D)x4.3''(H)	
	Color	Black	
	Texture	Deep texture by double etching method	
	Material	Metal & plastics	
	Front door key lock	Yes	Protected USB port and optical drive
	Spill & Dust Resistant	Yes	
Safety & Regulatory	UL/CSA	Yes	
	CE/CB	Possible Future Approval	
	CCC	Possible Future Approval	
	FCC/VCCI	Class-A	
Manufacture & Maintenance	Screws Max.	9 screws	
	Max time to replace major components	Less than 5 min	
	Test time	Less than 15 min	
	Clearly label jumpers & switches	Basically there is no hardware setting. (To use Software setting) Label or Marking is attached, if hardware setting is needed.	
	Identify rear panel connectors by color	Yes	

1.5.2. Power Supply

Item		Description		
Normal Voltage Range		100-240VAC, Single Phase, 47-63 Hz		
Output Voltage		DC	Load Range (Min)	Load Range(Max)
		+3.3V	0.3A	17A
		+5V	0.3A	22A
		+12VB	0A	18A
		+12VA	0A	18A
		-12V	0A	1.0A
Temperature	Operating	+10 to 50 degrees C		
	Not Operating	-40 to+60 degrees C		
Humidity	Operating	5% RH to85% RH		
	Not Operating	5% RH to95 % RH		
Shock		Able to withstand drop from 50mm three times		
Vibration		0.5G (5Hz to 60HZ) for 1 Hour x/y/z direction		

1.5.3. Temperature & Humidity

Item		Description
Temperature	Operating	0°C ~ 40°C (32° to 104°F); 15° C/Hr (Non-Condensing)
	Non-Operating	-20°C ~ 60°C (-4° to 140°F); 15° C/Hr (Non-Condensing)
Humidity	Operating	20 ~ 85% (Non-Condensing)
	Non-Operating	8 ~ 95% (Non-Condensing)

1.5.4. Shock & Vibration

Item		Description
Vibration	Operating	0.4G, 5~100Hz 15min sweep, every 15 minutes (X, Y, & Z Axis)
	Non-Operating	1.0G, 5~100Hz 15 min sweep, every hour (X, Y, & Z Axis)
Drop	Operating	A drop of 150cm (4' 11") to a concrete floor twelve times to the face, 8 times to each corner, and 6 times to each side.

1.5.5. Environmental

Item	Description
Water Resistance	IP52 (EC)

1.5.6. Safety & Regulatory

Item		Description
ESD	Air Discharge	±8KV
	Contact Discharge	±8KV
EMI Standards		FCC part 15 class B, Canada ICES-003 Class A
Safety Standard		CSA C22.2 No 60950

1.6. PERIPHERALS

TeamPoS 3000 XE offers a large assortment of peripherals. Many are color and style compatible with the TeamPoS 3000 XE control unit and they can be stacked on the control unit and/or cash drawer to form an integrated unit. Reference TP3000 XL SPG (#SPG-06-002).

1.6.1. RELIABILITY

The design life expectancy for the TeamPoS 3000 XE Terminal components are as follows.

Description	MTBF	MEASURE
Motherboard	100,000	POH
CPU	10,000,000	POH
CPU Heat Sink and Fan Kit	40,000	POH
Power Supply Unit (PSU)	400,000	POH
Chassis Cooling Fan	67,000	
HDD Unit	300,000	POH
HDD Unit-number of load & unload cycles	600,000	POH
CD-ROM Unit (Duty 10%)	60,000	POH
CD-RW/DVD (Duty 10%)	60,000	POH
Control Panel	2,984,000	POH
256 MB DDR DIMM	18,518,519	POH
512 MB DDR DIMM	37,037,038	POH
1 GB DDR DIMM	18,518,519	POH

1.6.2. LIFE EXPECTANCY

The design life expectancy for the components is as follows.

Description	Life
HDD Unit (Note 2)	>5 years at normal conditions
PSU FAN (Note 3)	>150,000 hours
CD-ROM drive unit	9,000 hours laser life 10,000 times loading of disk tray 2,000,000 seeks- feed motor life
Lithium Battery	>10 years

Notes:

- 1) The temperature condition is 25°C.
- 2) The life span is chosen from the parameter obtained first.
- 3) The life span is defined as maintaining 70% of specific rotation speed.
- 4) The life span is defined as maintaining 50% of specific brightness.
- 5) The MSR head cleaning per regular maintenance.

2. RESOURCES

The following sections list support, training, documentation, spares, repairs, and diagnostics available for the TeamPoS 3000 Models.

2.1. SKILLS REQUIRED

Customer Service Representative:

A good working knowledge of Intel-based PC components, POS peripherals, I/O card installation and supported operating systems is required. Prior experience and knowledge of POS terminals and their associated peripherals, Confidence Level Diagnostics (CLD), and commercial off-the-shelf PC diagnostics is assumed.

Consultant/Project Manager:

Good working knowledge of PCs, supported operating systems, and specific application experience is assumed.

Repair Center Technician:

An in-depth understanding of Intel-based PC components, POS peripherals, I/O cards, and supported operating systems is required. Knowledge of Confidence Level Diagnostics (CLD) and commercial off-the-shelf PC diagnostics is assumed.

Experience with troubleshooting multilayer PWAs, including surface mount technology (SMT) is required.

2.2. TRAINING

Field Service training is under the discretion of each specific business unit. Sustaining Engineering will provide 'train the trainer' operations. The schedule and funding for training will be established on an individual case by case basis. All requests for training by Sustaining Engineering should be forwarded to the Sustaining Mailbox (reference the cover page).

Sustaining Engineering estimates that the Technical Publications listed are adequate for this product and additional training will not be necessary for Field Service personnel currently trained on similar Fujitsu products. The TP3K XE should be included in any future standard training provided to Fujitsu Field Service personnel.

2.3. TECHNICAL PUBLICATIONS

Description	Part Number
Installation and Maintenance Manual	D900000171

2.4. SPARES

The TeamPoS 3000XE is a Fujitsu product and will follow standard spares lead times. It is assumed that organizations will spare the TeamPoS 3000XE at the FRU level. Some customers/organizations however, may choose to spare the major assembly level with the lower level repair performed at a central repair center or depot. The spares list takes both of these methods into consideration. Spares will be stocked at the North America Logistics Center (Frisco, USA24) and whole units should be returned on a RMA to the Logistics Center. You can refer to the Installation and Maintenance Manual for spare part information or also available Refer to Appendix F for Spares list .

2.5. REPAIR

North America Logistics Center (Frisco) offers repair services for the items they consider to be repairable. The OEM vendor also offers repair services that may be contracted by one of these repair centers or other organizations.

Logistics and Field Service organizations should utilize their own services to provide a test of units being returned from the field before shipment to repair centers as history has shown that not all units being returned from the field are actually faulty.

If faulty, logistics organizations may elect to have the repair done down to a component level replacement if parts and resources permit. However, this would be a local decision.

2.5.1. FIELD REPAIR TIME

The following are time estimates for removing and replacing major assemblies on site. These time estimates do not include the time to diagnose the problem, gain clear access to the TeamPoS 3000 XE, or perform any software reloading to return the unit to full customer functionality. It is assumed that this service is performed by a qualified and trained FE.

Description	Replacement Time (min)
Power Supply Unit	8 min.
Power Supply Fan	5 min.
Mother board	5 min.
Combo Board	2 min
USB Board	2 min.
HDD unit	2 min.
Memory	1 min.
CD-ROM unit	3 min.
Front Cover	0.5 min.
CPU & Heatsink	5 min.
Control Panel	3 min.
Battery	2 min.
Average MTTR for Complete Unit	5 min.

Based upon these times and adjusted by the probability of a specific component failing, the average MTTR for the complete unit is estimated at 5 minutes by a qualified field engineer.

	Fujitsu Transaction Solutions	SUPPORT PLANNING GUIDE TeamPos 3000XE	SPG-06-003
	Sustaining Engineering		Issue: 1.0
	San Diego, CA; Montreal , QC		January 4, 2007

2.5.2. DIAGNOSTICS

Two levels of diagnostics are provided.

- The first level consists of POST (Power-On Self Test) diagnostics, which are executed at power-on and test basic operations of the PC Motherboard.
- Windows Confidence Level Diagnostics (WINCLD) is the second level of diagnostics. CLD is a Windows based utility that allows a service engineer to identify POS problems to the ORU by performing Loopback tests on the RS232 ports and exercising the POS peripherals that are attached. Specific instructions for executing WINCLD can be found along with the latest version of WINCLD on the Internet FTP site.

Note: WINCLD needs OPOS loaded

Diagnostics for testing of the PC portion of the TeamPoS is accomplished via a commercially available diagnostic program. QA Plus is the diagnostic certified and recommended by Fujitsu. It can be obtained at a local computer sales facility. Future PC diagnostics software will be accessible on the hard disk.

2.5.3. SERVICE TOOLS

The following is a list of test/repair tools needed:

- 80303084 RS232 Loopback Plug-Male (used with WINCLD)
- 80203280 Printer Loopback Plug (used with WINCLD)
- 80203279 RS232 Loopback Plug-Female (used with WINCLD)
- Future +12V Powered USB Loopback Plug (used with WINCLD)
- Future +24V Powered USB Loopback Plug (used with WINCLD)
- Future Bootable USB key with on board diagnostics
- 7737171 MSR Cleaner Cards
- 80064971 MSR Test Cards

2.5.4. REPAIR TOOLS

No special tools are needed. 99% of replacement or repair can be done with a standard Phillips screwdriver.

	Fujitsu Transaction Solutions	SUPPORT PLANNING GUIDE TeamPos 3000XE	SPG-06-003
	Sustaining Engineering		Issue: 1.0
	San Diego, CA; Montreal , QC		January 4, 2007

3. SERVICE PROFILES

3.1. PREVENTATIVE MAINTENANCE

Beyond general cleaning of the TeamPoS 3000, there is no scheduled preventative maintenance required. However, the lead acid battery should be replaced every three years to insure proper battery back-up.

The life cycle for the Lithium Battery is more than 10 years and the Lead Acid Battery is more than 3 years.

General cleaning of the terminal, peripherals, and MSR is required on a regular basis. These procedures are described in the Installation and Maintenance Manual and are the responsibility of the customer. In particular, dust must be removed from internal components, air vents, fans, and exhaust screens to allow sufficient air flow to maintain proper cooling. Printers must also have paper dust/scraps removed regularly to maintain proper printer operation. The frequency of this cleaning will depend upon installed environments. Lack of this cleaning will greatly reduce equipment reliability. To achieve the MTBF for the MSR, cleaning with a MSR cleaner card must be performed approximately every 1,000 passes.

See Installation and Maintenance Manual for Specifications

3.2. CORRECTIVE MAINTENANCE

In the event of a failure the customer should be expected to confirm the malfunction by carrying out his or her own internal problem resolution procedures. If their procedures are unable to resolve the problem, they should contact their local Field Service/Support organization.

Field Service/Support organizations should provide a support desk facility whereby customers can telephone for advice before logging a service request. If telephone assistance is unable to resolve the problem, the local Field Service/Support organization should send a representative to assist, unless the RFR option/maintenance agreement was selected. Field Service/Support should affect on-site repairs to the FRU level recommended by their Field Service/Logistics management.

3.3. ESCALATION PROCEDURES

The escalation of product error reports or requests for assistance should take place in the following order. While some of these steps may be in the same organization, they are listed as individual steps to illustrate the 'functional' process flow.

Customer's Internal Service

First Line Support Service (Help Desk)

Field Service Organization

Field or Local Technical Support (FTS)

National Technical Support (NTS)

Sustaining Engineering

Development/Supplier Engineering – with Mgmt Escalation

Product reports raised on supported products or general inquiries should be sent to the Sustaining mailbox (reference the cover page).

4. APPENDIX A: FAILURE PER YEAR WORKSHEET

The following are specific variables that need to be determined for your specific customer configuration when calculating Failures Per Year (FPY).

Description	Variables
Avg. Power On Hours per Year (8736 max)	(A) _____
Avg. 'Green Mode' Power On Hours per Year	(B) _____
Avg. Transactions per Trading Hour	I _____
Avg. Trading Hours per day	(D) _____
Avg. Trading Days per Week	(E) _____
Avg. Keystrokes per Transaction	(F) _____
Avg. Keylock Cycles per Transaction	(G) _____
Avg. MSR Usage's per Transaction (1 out of 3=.33)	(H) _____
Avg. Print Lines per Transaction	(I) _____
Avg. Cash Drawer Openings per Transaction	(J) _____
Avg. Transaction per Terminal Year (C*D*E*52wks)	(K) _____

Units Affected by Power On Hours:

Device	Power On Hours	/ MTBF Hours	=	FPY
*	(A) _____	/	*	= _____
*	(A) _____	/	*	= _____
*	(A) _____	/	*	= _____
*	(A) _____	/	*	= _____
*	(A) _____	/	*	= _____
Power On Total				_____

Units Affected by Green Mode Operational Hours:

Device	Power On Hours	/ MTBF Hours	=	FPY
*	(B) _____	/	*	= _____
*	(B) _____	/	*	= _____
*	(B) _____	/	*	= _____
*	(B) _____	/	*	= _____
*	(B) _____	/	*	= _____
Green Mode Total				_____

Units Affected by Mechanical Usage:

Keyboard:	(F) x (K) / *	=	_____	
Keylock:	(G) x (K) / *	=	_____	
MSR:	(H) x (K) / *	=	_____	
Printer:	(I) x (K) / *	=	_____	
Cash Drawer:	(J) x (K) / *	=	_____	
Mechanical Total				_____

Total for your customer configuration (per lane):

Power On Total	_____
Green Mode Total	_____
Mechanical Total	_____
Total FPY Per Lane	_____

Note: This total does not include failures resulting from use of consumables (batteries, print heads, etc.), cables, software/firmware based problems, no-fault-founds, or resulting from use not considered standard for this type of equipment.

5. APPENDIX B: MOTHERBOARD

Connector Introduction:

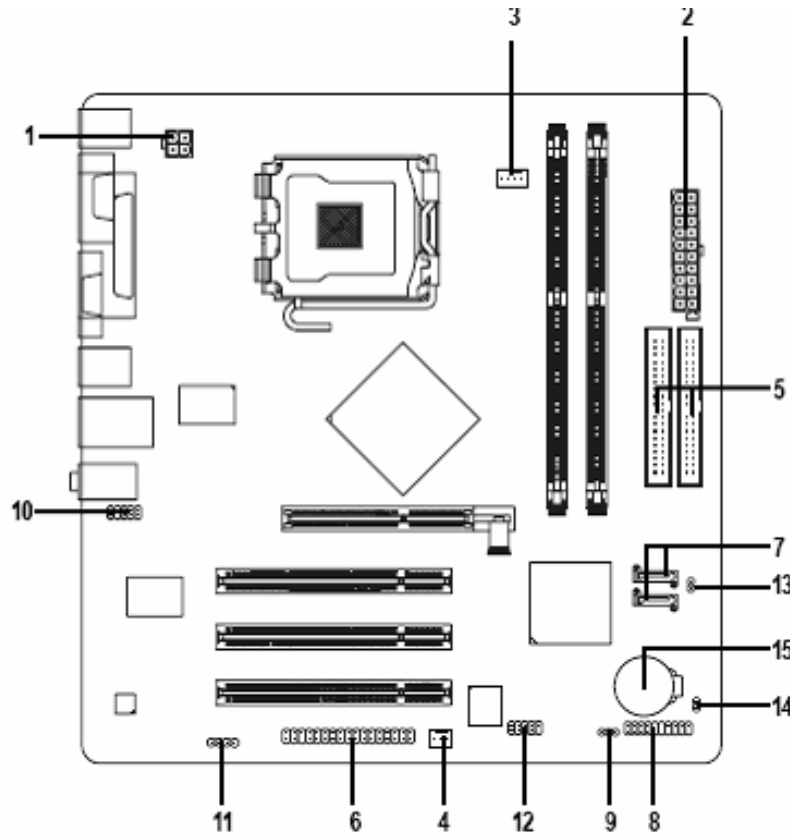

1.	ATX 12V
2.	ATX (Power Connector)
3.	CPU Fan Power Connector
4.	System Fan Connector
5.	HDD IDE/1 IDE/2
6.	FDD
7.	SATA0 / SATA1
8.	Front Panel
9.	Power LED
10.	Front Audio
11.	CD In
12.	Front USB1
13.	CI
14.	Clear CMOS
15.	BATT

	Fujitsu Transaction Solutions	SUPPORT PLANNING GUIDE TeamPos 3000XE	SPG-06-003
	Sustaining Engineering		Issue: 1.0
	San Diego, CA; Montreal , QC		January 4, 2007

6. APPENDIX C: BIOS SETUP PROCEDURES

If a motherboard is replaced in the field, it may be necessary to change the date and time and setup the BIOS for the customer's configuration. The following information shows the default screens from the factory.

Opening CMOS Setup Screen

Turn ON power and press the "F2" key while the terminal goes through the power on self test.(POST). You can also enter the BIOS setup screen by pressing CTRL+F1.

When setting up BIOS for the first time, save the current BIOS to a disk in the event that BIOS needs to be reset to its original settings.

CMOS Settings

If this is a new motherboard it will be necessary to set the date and time before releasing the terminal to the customer. To change the date and time select STANDARD CMOS FEATURES and manually make changes by inserting the current date and time. Run "LOAD OPTIMIZED DEFAULTS" then "SAVE & EXIT SETUP." Changing other default settings may be done at this time if the customer has settings other than the default settings listed here.

Changing settings that are not the default or not set for specific customer needs may adversely effect the operation of the unit.

In most cases, the CMOS default settings are adequate and do not require changing. Follow the instructions on the screen to select STANDARD CMOS FEATURES.

Main Menu

Note: An arrow [▶] indicates additional screens. Press [Enter] to advance to the next screen. Text shown in gray is dynamic meaning it either changes as the unit operates, or it is set for automatic mode and is not selectable in that mode.

Instructions or information on how to change settings appears in the right column under “Item Help.” Information appropriate to the item selected appears under “Menu Level.”

Factory Default Settings

CMOS Setup Utility © 1984-2006 Award Software	
↕▶ Standard CMOS Features ←▶ Advanced BIOS Features →▶ Integrated Peripherals ↑▶ Power Management Setup ↓▶ PnP/PCI Configurations ↔▶ PC Health Status	Frequency/Voltage Control Load Optimized Defaults Set Supervisor Password Save & Exit Setup Exit Without Saving
Esc: Quit F8: Q-Flash	↑ ↓ → ← : Select Item F10: Save & Exit Setup
Time, Date, Hard Disk Type...	

Advanced BIOS Features Setup

This setup page includes all the items of special enhanced features.

Factory Default Settings

CMOS Setup Utility © 1984-2006 Award Software Advanced BIOS Features			
▶	Hard Disk Booth Priority	[Press Enter]	Item Help
	First Boot Device	[Floppy]	
	Second Boot Device	[Hard Disk]	Menu Level ▶
	Third Boot Device	[CDROM]	
	Password Check	[Setup]	<i>Information or instructions will appear here for each selection</i>
#	CPU Hyper-Threading	[Enabled]	
	Limit CPUID Max. to 3	[Disabled]	
	No-Execute Memory Protect ^(Note)	[Enabled]	
	CPU Enhanced Halt (CIE) ^(Note)	[Enabled]	
	CPU Thermal Monitor 2(TM2) ^(Note)	[Enabled]	
	CPU EIST Function ^(Note)	[Enabled]	
	Unit Display First	[PCI]	
	On-Chip frame Buffer Size	[16MB]	
↑ ↓ → ← : Move Enter : Select +/-/PU/PD : Value F10 : Save ESC : Exit F1: General Help			
F5: Previous Values F6: Fail-Safe Default F7: Optimized Defaults			

Load Fail-Safe Defaults

Fail-Safe Defaults indicate the value of the system parameters which the system would have in safe configuration.

Factory Default Settings

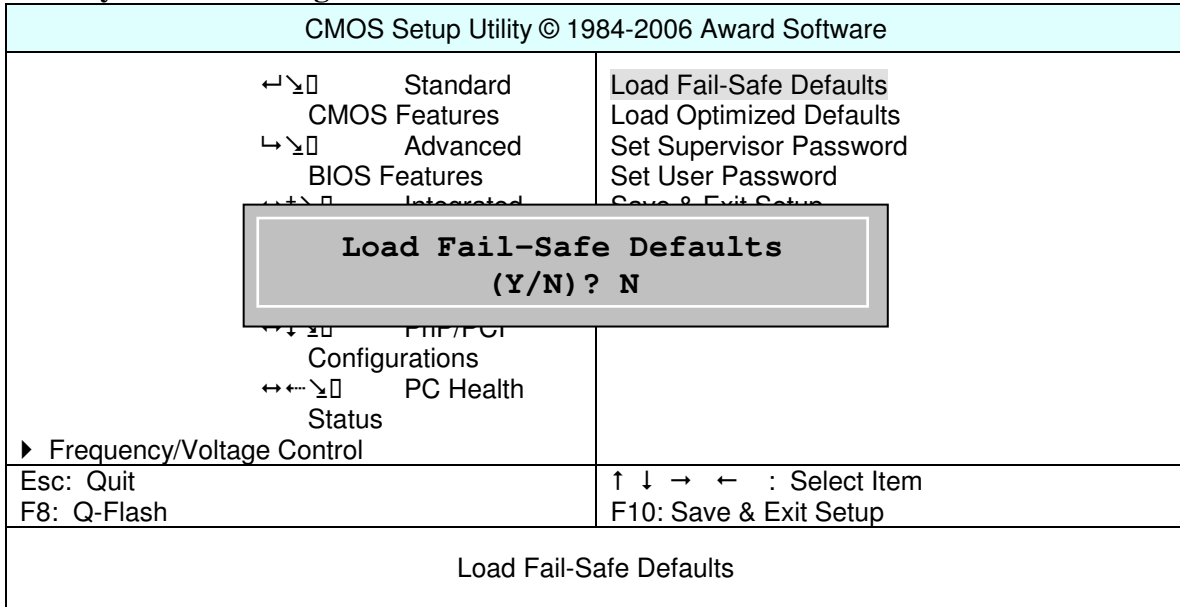

Load Optimized Defaults

Optimized Defaults indicates the value of the system parameters which the system would have in best performance configuration.

Factory Default Settings

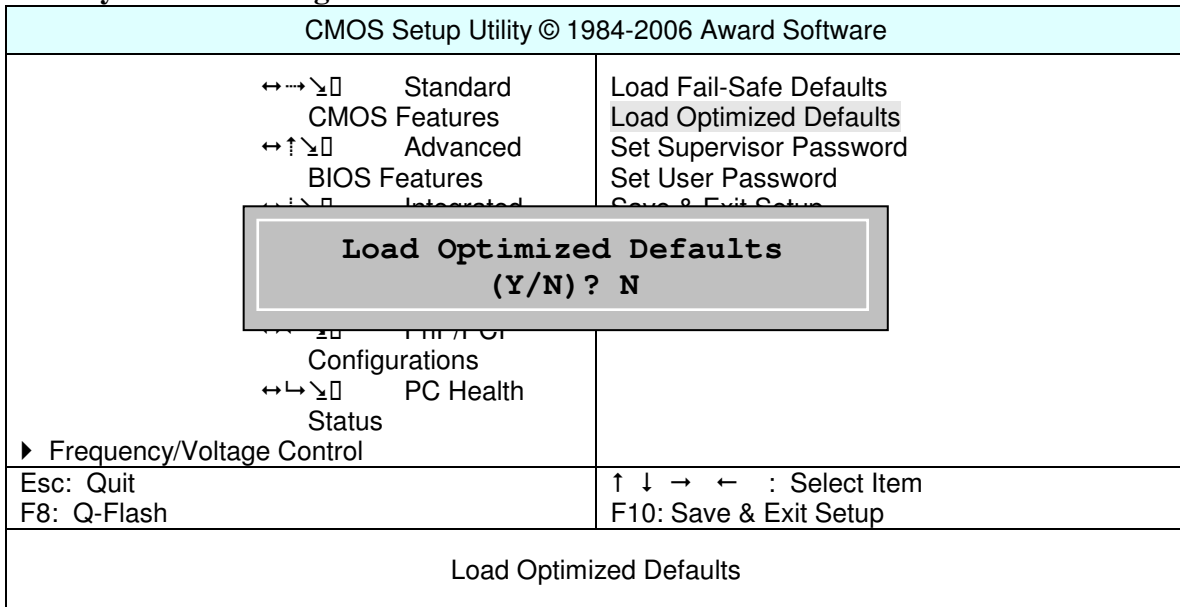

Set Supervisor Password

Change, set, or disable password. It allows you to limit access to the system and setup, or just to setup.

The BIOS Setup program allows you to specify two separate passwords: SUPERVISOR PASSWORD and a USER PASSWORD. When disabled, anyone may access all BIOS Setup program functions. When enabled, the Supervisor password is required for entering the BIOS Setup program and having access to full configuration fields.

The User password is required to access only basic items.

If you select “System” at “Password Check” in Advance BIOS Features Menu, you will be prompted for the password every time the system is rebooted or any time you try to enter Setup Menu.

If you select “Setup” at “Password Check” in Advance BIOS Features Menu, you will be prompted only when you try to enter Setup.

Factory Default Settings

CMOS Setup Utility © 1984-2006 Award Software	
↑↓↘☐ Standard CMOS Features ↔↘☐ Advanced BIOS Features ↑↑↘☐ Integrated ↑↘↘☐ PnP/PCI Configurations ↑↑↘☐ PC Health Status ▶ Frequency/Voltage Control	Load Fail-Safe Defaults Load Optimized Defaults Set Supervisor Password Set User Password Save & Exit Setup
<div style="border: 1px solid black; padding: 5px; width: fit-content; margin: 0 auto;"> Set Password: </div>	
Esc: Quit F8: Q-Flash	↑ ↓ → ← : Select Item F10: Save & Exit Setup
Change/Set/Disable Password	

Set User Password

Change, set, or disable password. It allows you to limit access to the system.

Factory Default Settings

CMOS Setup Utility © 1984-2006 Award Software	
↑↓↘☐ Standard CMOS Features ↑↔↘☐ Advanced BIOS Features ↑↘☐ Integrated ↓☐ PC Health ←↔↘☐ PC Health Status ▶ Frequency/Voltage Control	Load Fail-Safe Defaults Load Optimized Defaults Set Supervisor Password Set User Password Save & Exit Setup
<div style="border: 1px solid black; padding: 5px; width: fit-content; margin: 0 auto;"> Set Password: </div>	
Esc: Quit F8: Q-Flash	↑ ↓ → ← : Select Item F10: Save & Exit Setup
Change/Set/Disable Password	

Save & Exit Setup

Saves CMOS value settings to CMOS and exits setup.

Factory Default Settings

CMOS Setup Utility © 1984-2006 Award Software	
←↔↑↘☐ Standard CMOS Features ←↔↔↘☐ Advanced BIOS Features ←↔↔↘☐ Integrated Peripherals ←↔↔↘☐ PC Health Status ▶ Frequency/Voltage Control	Load Fail-Safe Defaults Load Optimized Defaults Set Supervisor Password Set User Password Save & Exit Setup Exit Without Saving
<div style="border: 1px solid black; padding: 5px; width: fit-content; margin: 0 auto;"> Save to CMOS and EXIT (Y/N)? Y </div>	
Esc: Quit F8: Q-Flash	↑ ↓ → ← : Select Item F10: Save & Exit Setup
Save Data to CMOS	

Exit without Saving

Abandons all CMOS value changes and exits setup.

Factory Default Settings

CMOS Setup Utility © 1984-2006 Award Software	
<div style="display: flex; justify-content: space-between;"> <div style="width: 45%;"> <p>←→ ↵ □ Standard CMOS Features</p> <p>←→ ↵ □ Advanced BIOS Features</p> <p>→ ↵ □ Integrated Peripherals</p> </div> <div style="width: 45%;"> <p>Load Fail-Safe Defaults Load Optimized Defaults Set Supervisor Password Set User Password Save & Exit Setup Exit Without Saving</p> </div> </div>	
<div style="border: 2px solid gray; padding: 5px; display: inline-block; background-color: #f0f0f0;"> Quit Without Saving (Y/N)? N </div>	
<p>Configurations</p> <p>→ ← ↵ □ PC Health</p> <p>Status</p> <p>▶ Frequency/Voltage Control</p>	
<p>Esc: Quit F8: Q-Flash</p>	<p>↑ ↓ → ← : Select Item F10: Save & Exit Setup</p>
Abandon all Data	

7. APPENDIX D: I/O BOARD CONNECTOR PINOUTS AND JUMPERS

CONNECTOR SIGNALS

	COM 3 4	Com 5	USB +24V (RED)	USB +12V Green
			Ports C-Red powered USB connector	Ports-all Green powered USB connectors
1	CD	Gnd	5V USB Pwr	5V USB Pwr
2	RX	RX	Data -	Data -
3	TX	TX	Data +	Data +
4	DTR	CTS	Gnd	Gnd.
5	Gnd	DSR	+24V Return	+12V Return
6	DSR	CD	+24V Pwr	+12V Pwr
7	RTS	Gnd	+24V Pwr	+12V Pwr
8	CTS	24V Ret	+24V Return	+12V Return
9	+5V/+12V	RI		
10		VCC/USB1		
11		DTR		
12		RTS		
13		24V Ret		
14		+24V		
15		+24V		

Note: See the Installation and Maintenance Manual for removal and replacement of these cards.



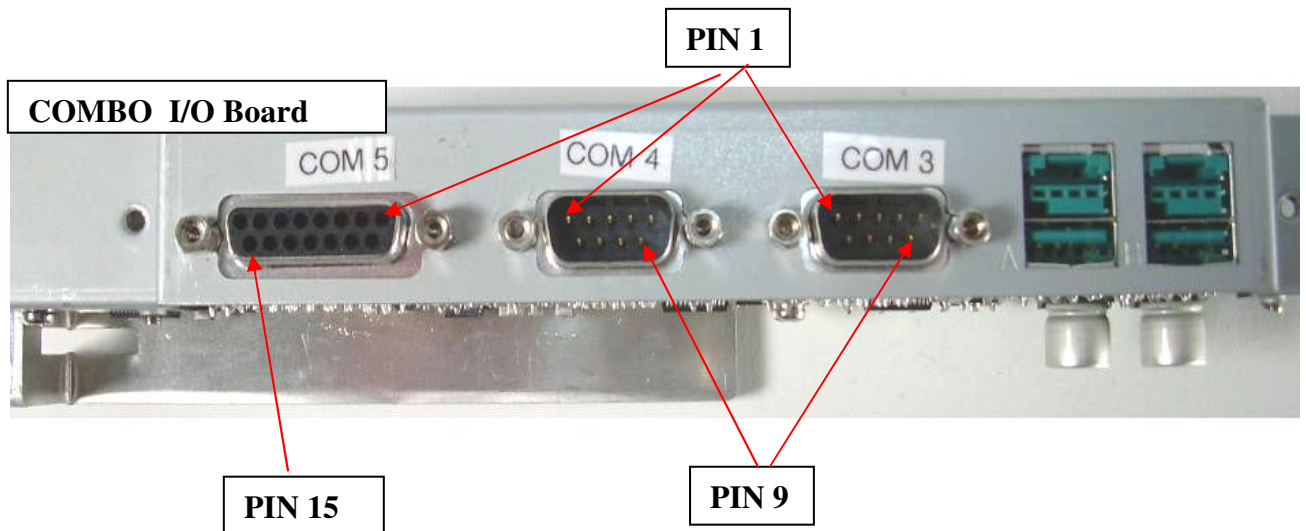
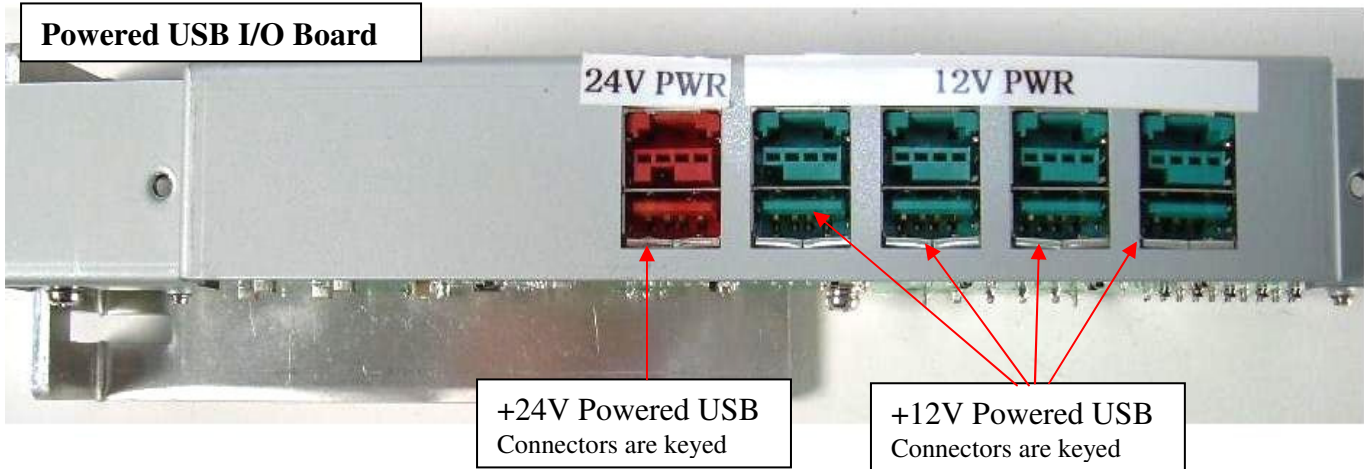

COMBO I/O Board JUMPER SETTING

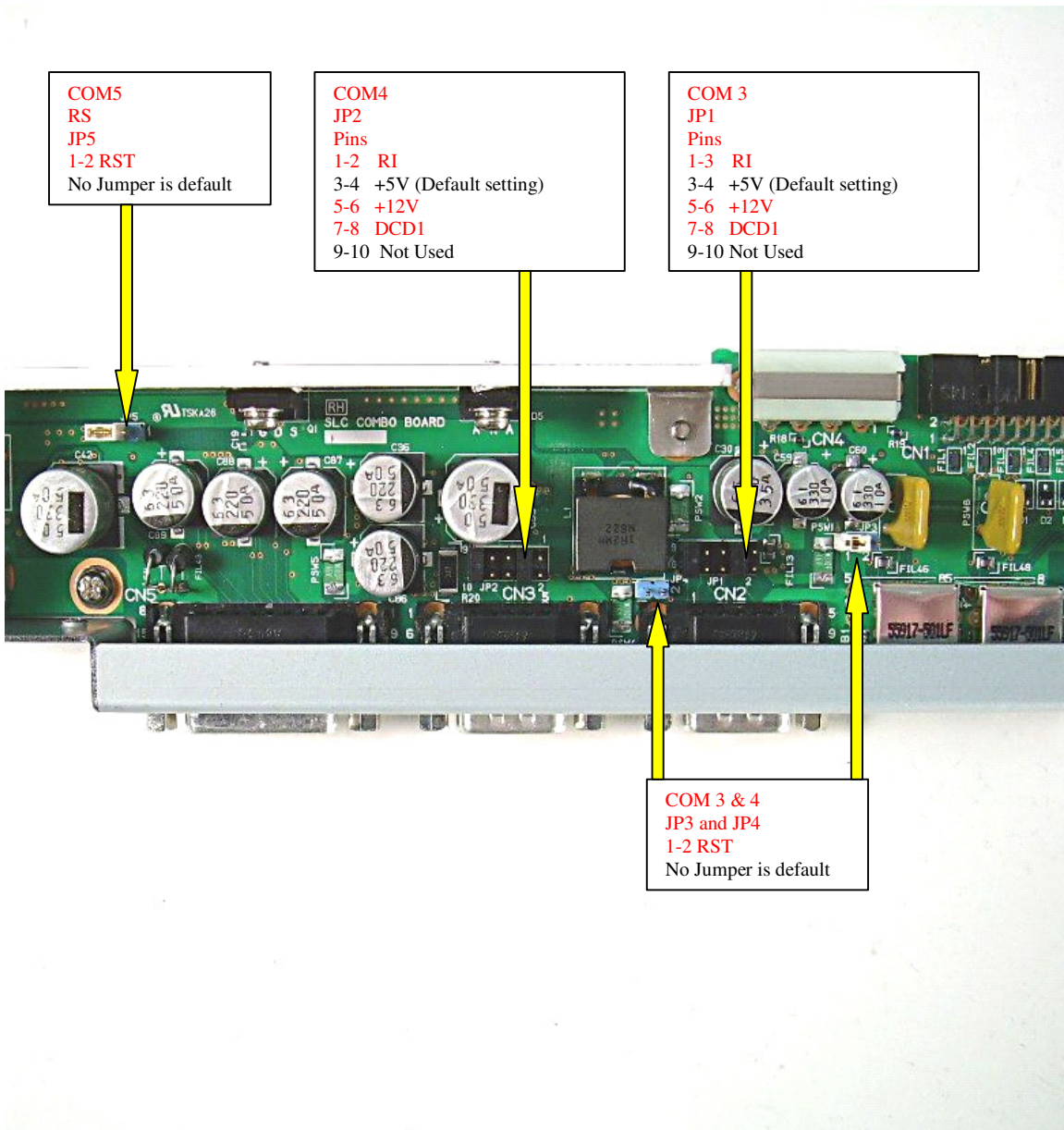

8. APPENDIX E: ORDERABLE CONFIGURATIONS

The TeamPoS 3000 XE can be ordered in the following two fixed configurations at this time:

Order Part #	Description
11001157	Controller, TeamPOSP 3000 XE, Combo Board, Black Color
11001156	Controller, TeamPOS 3000 XE, USB Board, Black Color

9. APPENDIX F: SPARES PARTS LIST

These part lists are provided as a reference and planning purposes only.

DESCRIPTION	PART NUMBER	NOTES
Controller		
Controller, TeamPOS 3000 XE, 2.93 Ghz Intel Celeron D, 512MB Non ECC, COMM I/O Board, BLACK	11001157	
Controller, TeamPOS 3000 XE, 2.93 Ghz Intel Celeron D, 512MB Non ECC, Powered USB/I/O Board, BLACK	11001156	
Chassis Kit, BLACK	11001063	
Chassis Kit, WHITE	11001062	
Motherboards(s)		
Motherboard	11001158	GA-81865GME-775-RH
CPU Options		
CPU	11001064	2.93 Ghz Intel Celeron D
CPU FAN KIT	11001159	Heat Sink and Fan
Memory Options		
Memory 256K	11001058	
Memory 512K	11001059	
Memory 1G	11001060	
Memory 2G	11001061	
Power Supply (PSU)		
Power Supply (PSU)	11001160	
Power Cord	11000049	
Misc Chassis Parts		
PNL Front/Keylock/Black	11000177	Front Panel
Chassis Cooling Fan	KD30341-0920	Fan 40mm 12V
Control Panel	11000179	
Control Panel Cable	KD02907-6460	MB to Control Panel
Hard Disk Options		
HDD	11001364	80Gig
HDD	11001067	40Gig
Cable	KD02907-6461	MB to HDD (SATA)
CD Drive Options		
CD-ROM/WHITE	11001068	
CD-ROM/BLACK	11001069	
CD/RW/DVD/WHITE	11001070	
CD/RW/DVD/BLACK	11001071	
I/O Board Options		
I/O POWERED USB BOARD	11001065	
COMBO I/O BOARD	11001066	
PCI Board	KD02907-6455	
Cable	KD02907-6459	PCI Board to USB I/O Board or Combo Board