

	Fujitsu Transaction Solutions	SUPPORT PLANNING GUIDE TeamPoS 3000 XL Terminal	SPG-06-002A
	Sustaining Engineering		Issue: 2.0
	San Diego, CA; Montreal QC		April 23, 2008

Subject: TeamPoS 3000 XL Series Hardware Platform

SYNOPSIS

This document is intended to supply sufficient information to North American service planners to enable them to plan for the introduction of the above product(s).

This SPG is the generic version, released by the product authority, Fujitsu Transaction Solutions (FTXS), Sustaining Engineering. Each group releasing the product will use the information contained as the basis for their Logistics and Field Service planning activities.

This document details only the corporate philosophies, and does not seek to cover such subjects as additional services offered by Managed Services, third party service providers, low level repairs, or the local sourcing of components and consumable items.

The service descriptions in this document are guidelines, detailing the recommendations of the product authority. The information within this document has been reviewed for accuracy, but as with most documents, errors may be found and corrected in future revisions. Fujitsu Transaction Solutions (FTXS) cannot be held liable for any inaccurate information found in this document.

<u>INQUIRIES TO:</u>		DATE
Fujitsu Transaction Solutions Inc.		
Exchange:	Sustaining Engineering	_____
Mail:	Fujitsu USA04, Sustaining Engineering	_____
FAX:	858-731-4781 (7888-4781)	_____
Internet:	sustainingengineering@ftxs.fujitsu.com	_____
FTP:	ftp://ftp.ftxs.fujitsu.com/	_____
Original signature copies maintained by Sustaining Engineering.		

0.	DOCUMENT CONTROL	4
0.1.	ISSUE LEVEL	4
0.2.	CHANGES FROM PREVIOUS ISSUE	4
0.3.	TERMS AND ABBREVIATIONS	4
0.4.	REFERENCE DOCUMENTS	4
1.	OVERVIEW	5
1.1.	RELEASE SCHEDULE	6
1.2.	PRODUCT DESCRIPTION	7
1.3.	SOFTWARE	7
1.4.	HARDWARE	7
1.4.1.	PC Motherboard.....	9
1.4.2.	Docking Backplane (XL Models Only).....	10
1.4.3.	Front Operator Panel.....	15
1.4.4.	Power Supply Unit (PSU).....	16
1.4.5.	Batteries.....	16
1.4.6.	Disk Drives.....	16
1.4.7.	CD-ROM.....	16
1.5.	SPECIFICATIONS	17
1.6.	PERIPHERALS	19
1.6.1.	Printers.....	19
1.6.2.	Keyboards.....	19
1.6.3.	Displays.....	19
1.6.4.	Cash Drawers.....	22
1.7.	PRODUCT PERFORMANCE	23
1.7.1.	RELIABILITY.....	23
1.7.2.	LIFE EXPECTANCY.....	24
2.	RESOURCES	25
2.1.	SKILLS REQUIRED	25
2.2.	TRAINING	25
2.3.	TECHNICAL PUBLICATIONS	25
2.4.	SPARES	25
2.5.	REPAIR	25
2.5.1.	FIELD REPAIR TIME.....	26
2.6.	TOOLS	27
2.6.1.	DIAGNOSTICS.....	27
2.6.2.	SERVICE TOOLS.....	27
3.	SERVICE PROFILES	28
3.1.	PREVENTATIVE MAINTENANCE	28
3.2.	CORRECTIVE MAINTENANCE	28
3.3.	ESCALATION PROCEDURES	28
4.	APPENDIX A: FAILURE PER YEAR WORKSHEET	29
5.	APPENDIX B: MOTHERBOARDS	30
6.	APPENDIX D: DOCKING BACKPLANE	46
7.	APPENDIX E: BIOS	47

	Fujitsu Transaction Solutions	SUPPORT PLANNING GUIDE TeamPoS 3000 XL Terminal	SPG-06-002A
	Sustaining Engineering		Issue: 2.0
	San Diego, CA; Montreal QC		April 23, 2008

XL² MOTHERBOARD BIOS SCREEN	58
8. APPENDIX F: INTELLIGENT PIN (15000099)	74

	Fujitsu Transaction Solutions	SUPPORT PLANNING GUIDE TeamPoS 3000 XL Terminal	SPG-06-002A
	Sustaining Engineering		Issue: 2.0
	San Diego, CA; Montreal QC		April 23, 2008

0. DOCUMENT CONTROL

0.1. ISSUE LEVEL

This is the second issue of this document, introducing the TeamPoS 3000 Series hardware platform into the Fujitsu Retail product line.

0.2. CHANGES FROM PREVIOUS ISSUE

Basic changes to issue 2.0 (-002A) are addition of XL² Motherboard and associated changes and other misc corrections and updates.

- Pg. 4 – Added additional abbreviations
- Pg. 5 – Updated Overview and Release Schedule
- Pg. 6 – Updated Hardware section
- Pg. 7 – Updated Software section
- Pg. 8 – Updated Motherboard section
- Pg. 9 – Updated Docking Backplane section
- Pg. 10 – Updated Interface Boards section
- Pg. 11 – Updated Combo Card section
- Pg. 12 – Updated COM Card section
- Pg 17 – Removed 88U keyboards from keyboard options
- Pg 22 – Removed 88U keyboard, and updated reliability chart
- Pg 24 – Updated Technical Documents
- Pg 25 – Added screwdrivers to the tools section
- Pg 29 – Separated Appendix B into two different motherboards
- Pg 46 – Updated BIOS introduction
- Pg 57-71 – Added XL² Motherboard BIOS settings
- Pg 72 – Updated Intelligent PIN configuration

0.3. TERMS AND ABBREVIATIONS

AFR	Annualized Failure Rate
CLD	Confidence Level Diagnostic Software
EMI	Electromagnetic Interference
ESD	Electrostatic Discharge
FDD	Floppy Disk Drive
FPY	Failures Per Year
FRU	Field Replaceable Units
FSB	Front Side Buss
FTS	Field Technical Support
FWH	Firmware Hub
HDD	Hard Disk Drive
MSR	Magnetic Strip Reader
MTBF	Mean Time Between Failures
MTTR	Mean Time To Repair
NTS	National Technical Support
POH	Power On Hours
PSU	Power Supply Unit
SPG	Support Planning Guide
UPC	Universal Product Code (Bar Code)
VFD	Vacuum Florescent Display

0.4. REFERENCE DOCUMENTS

KD96009-0401 User's Guide

	Fujitsu Transaction Solutions	SUPPORT PLANNING GUIDE TeamPoS 3000 XL Terminal	SPG-06-002A
	Sustaining Engineering		Issue: 2.0
	San Diego, CA; Montreal QC		April 23, 2008

1. OVERVIEW

The TeamPoS 3000 terminal is the current generation of the Fujitsu POS terminal. There are a total of four new models introduced. The XL model was released in April of 2006, the XL² model was released in April of 2008, the XT model released in December of 2006, and the XE was released in January of 2007.

- TeamPoS 3000 XL (High-end POS)
- TeamPoS 3000 XL² (High-end POS)
- TeamPoS 3000XT (All-in-One POS)
- TeamPoS 3000XE (Entry Level POS)

This SPG addresses only the XL and the XL² models. The XT and XE models are covered separately in other SPGs. Updated SPG's will follow as new models are introduced and changes are made.

The original XL and XT models, introduced with the SHE (Super High End) motherboard can use either the Celeron M or Pentium M processors with up to 2GB of ECC memory. The SHE motherboards utilize serial ATA (SATA) drives and can be used in a RAID configuration. The XE model uses a maximum of one Serial ATA drive (SATA) and therefore cannot support RAID.

The new XL² motherboard can support Celeron single core or Core 2 Duo CPU's and unbuffered DDR2 SO-DIMM (non-ECC) memory. The motherboard also uses a new mobile GME965 (North Bridge) and ICH8MDO (South Bridge) chipset that support 1GB LAN.

1.1. RELEASE SCHEDULE

Description	Release Date
Chassis	
High-End (XL) Controller Chassis	Apr 2006
All-in-One (XT) Small Footprint Chassis	Dec 2006
Low Cost (XE) Controller Chassis	Jan 2007
High-end (XL ²) Controller Chassis W/1GB LAN	Apr 2008
Keyboards	
133AU Keyboard	May 2008
Displays	
D22 12" LCD/TFT/TCH (Resistive)	Apr 2006
D22 12" LCD/TFT/ No TCH	Apr 2006
D25 15" LCD/TFT/TCH (Resistive)	Apr 2006
D25 15" LCD/TFT/No TCH	Apr 2006
D25 15" LCD/TFT/TCH (IR)	Jul 2006
Printers	
DT50III	Mar 2006
TM-T88III	Oct 2003
CT10 Printer	Apr 2006
TM-T88IV	Mar 2008
VFD Displays	
VF60 – USB Customer Display	Apr 2006
TeamPoS 3000 Components	
Motherboard - M (Same for Models XL and XT)	Apr 2006
Motherboard – XL ²	Apr 2008
Docking Backplane (removable on XL model only)	Apr 2006
Docking Backplane - 1GB LAN	Apr 2008
CD-ROM (Read only)	Apr 2006
CD-RW (DVD)	Apr 2006
Serial ATA Hard Disk Drive, 40GB	Apr 2006
Serial ATA Hard Disk Drive, 80GB	Apr 2006
CPU, Celeron M - 1.3, 1.5, 2.0 GHz, Pentium M – 1.6 –Hz	Apr 2004
CPU, Celeron M550 - 2.0 GHz, Pentium M – 1.8 & 2.2 GHz Core 2 Duo	Apr 2008
DDR Memory- 256MB, 512MB, & 1GB	Apr 2006
DDR2 Memory – 512MB, 1GB, & 2GB	Apr 2008
Control Panel	Apr 2006
Misc. New Peripherals	
TP15 Compact and Standard Cash Drawers	Apr 2006
MSR for D22 and D25 LCD's	Apr 2006
Keypad/MSR for D22 & D25	Apr 2006

	Fujitsu Transaction Solutions	SUPPORT PLANNING GUIDE TeamPoS 3000 XL Terminal	SPG-06-002A
	Sustaining Engineering		Issue: 2.0
	San Diego, CA; Montreal QC		April 23, 2008

1.2. PRODUCT DESCRIPTION

TeamPoS 3000 XL is currently available in the following models:

- Compact XL White or Black Color (with or w/o partial battery backup)
- Standard XL White or Black Color (with or w/o partial battery backup)
- Compact XL² White or Black Color (with or w/o partial battery backup)
- Standard XL² White or Black Color (with or w/o partial battery backup)

A small Phillips head and flat head screwdriver are required for major component replacement. Hard disk drives are user swappable and are easily accessible by removing the front panel.

1.3. SOFTWARE

The TeamPoS 3000 XL control unit has been validated on Windows 2000, Windows XP, Windows XPe, Windows XP Pro, and WEPOS operating systems, Vista Business has not been validated at the present time, but is expected to be validated by the end of 2008. Other operation systems may be certified in the future depending upon demand and business case. Only 32 bit versions of Windows 2000, Windows server 2003, Windows XP, XPe, and WePOS have been certified

Because there are several software options, none are standard with TeamPoS 3000. Other software components such as, device drivers and applications are configuration and customer specific. Also available are Remote Management and a Confidence Level Diagnostics program.

1.4. HARDWARE

The TeamPoS 3000 XL is equipped with the following features:

- Remote Systems Management
- Warm Swappable RS232 PoS Peripherals
- On Board RAID Controller
- Hot Swappable USB Peripherals and Hard Disk Drives (with dual disk drives only)
- Disk Drives Removable from Front of Terminal
- Optional 1GB Flash Memory
- Optional Wireless LAN
- Mean Time to Replace Most Major ORUs is 3-4 Minutes
- Power Savings Feature
- Optional Battery for Partial Battery Backup
- Optional Extended Battery Backup
- On-board Audio, Video, and LAN
- USB Support (Two Standard 2.0 USB ports in front and two in rear)
- Powered RS232/USB Ports (Based on Option Boards Installed)
- Support for most TeamPoS 2000 POS Peripherals
- Serial ATA Disk Drives
- Optional CD-ROM or CD-RW/DVD

Pictured on the following page is a TeamPoS 3000 XL Standard Black Unit without Cash Drawer configured with a 133UQ keyboard, a DT50III Printer, and a D25 LCD.

The major components of the TeamPoS 3000 control unit are:

- PC Motherboard with on board LAN and video
- I/O Option Boards
- Operation Panel Board
- Power Supply Unit and Fan
- Docking Backplane
- Batteries [Lead Acid (Optional) and Lithium]
- Optional Hard Disk Drives (2.5" SATA Drives)

	Fujitsu Transaction Solutions	SUPPORT PLANNING GUIDE TeamPoS 3000 XL Terminal	SPG-06-002A
	Sustaining Engineering		Issue: 2.0
	San Diego, CA; Montreal QC		April 23, 2008

- Optional CD-ROM (Read Only), or CD-RW/DVD



1.4.1. PC Motherboard

There are two different motherboards available on the TeamPoS 3000 terminal.

XL

The XL motherboard incorporates a 855GME and ICH4 chipset, supports serial ATA hard disk drives, has a built in Raid controller, and can support up to a 2.0 GHz Pentium M processor. The motherboard uses Award BIOS and supports ECC memory. A listing of the default settings can be found in Appendix E. A detailed description of the motherboard, its jumpers, and specifications can be found in Appendix B.

XL²

The XL² motherboard incorporates a GME965 and ICH8MDO chipset and supports Single or Core 2 Duo CPU chips. The motherboard supports DDR2 SO-DIMM up to 4GB (two slots at 2GB ea., non-ECC). The XL² motherboard supports serial ATA hard disk drives, has RAID capabilities, and can support up to a 2.2 GHz Core 2 Duo processor.

Both motherboards come spared on a metal base that slides into the TP3000 behind the front cover. A lever behind the front cover makes for easy insertion and withdrawal of the motherboard.

1.4.2. Docking Backplane (XL Models Only)

The TP3000 docking backplane and power supply rest together on one metal platform that slides in and out from the rear of the terminal. One phillips head screw retains a sliding locking bar at the rear of the terminal that secures the docking backplane to the chassis. To remove the docking backplane and power supply from the back of the terminal, first remove the power cord and then remove the screw and sliding locking bar. The whole docking backplane can then be removed by sliding the docking backplane out the rear of the terminal. Note: the Phillips screw holding the sliding locking bar must be in place and tightened during normal operation, otherwise a secure seating of the motherboard and docking backplane may not occur.

The docking backplane is used to provide signals and power from the motherboard and power supply to the interface boards located in the rear of the terminal. A picture of the docking backplane with power supply and interface boards installed is seen below.

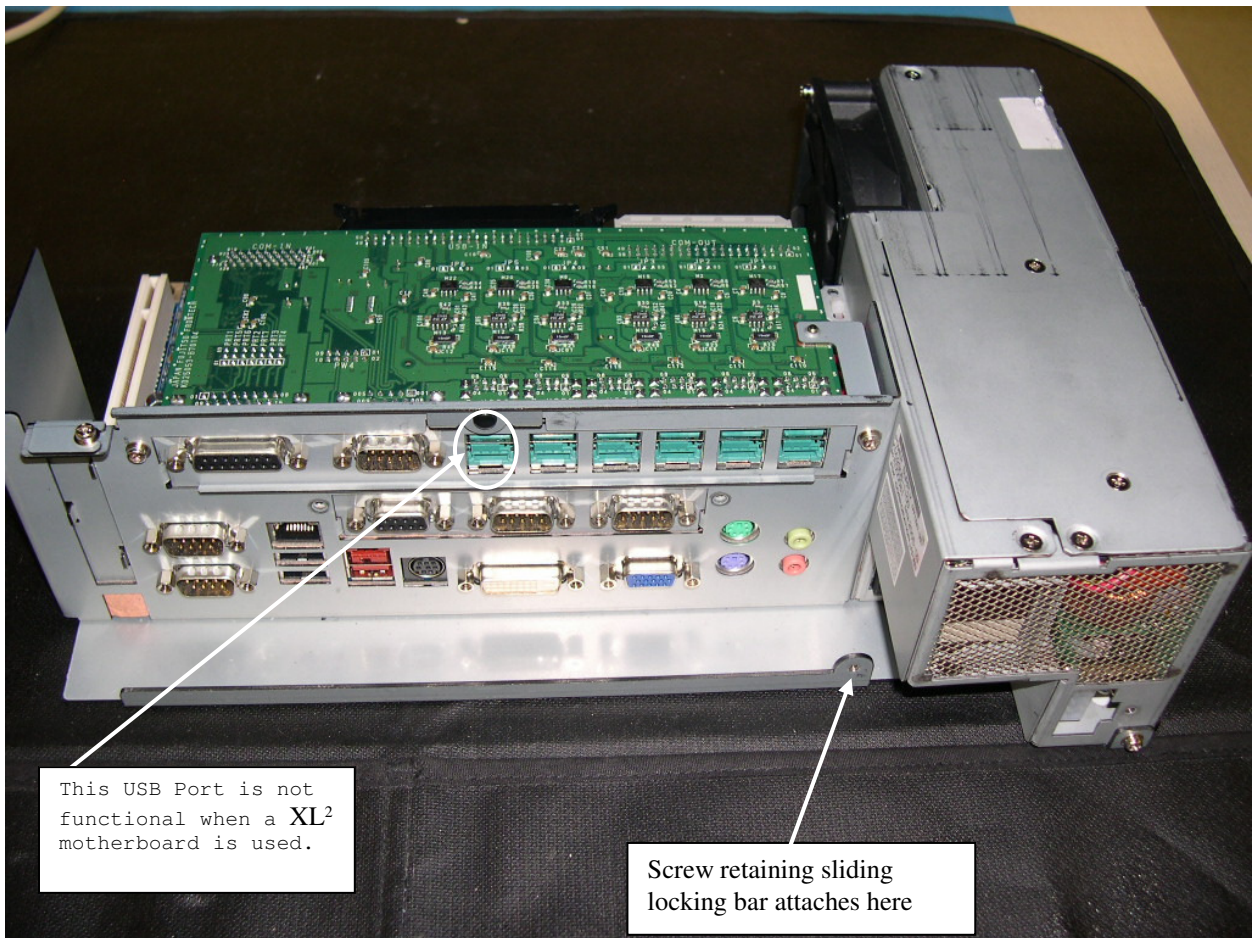

See Appendix D for jumpers and connector layout.

Interface Boards

There are three different interface boards available on the XL motherboard and two interface boards available for the XL² motherboard (XL² doesn't support the COM card). The picture below shows the rear of the terminal with XL motherboard and two interface cards installed. Combo cards provide support for both USB and legacy devices. In the picture below the combo card is seen in the top portion of the picture. The COM Card is located below the Combo card and the terminal must have the Combo Card installed in order to use the COM Card. The Combo Card can be used by itself or with COM Card. The third interface board is shown later in this chapter. See the Installation and Maintenance Manual for removal and replacement of these cards. The two USB ports located below the LAN can be used to boot from external USB devices such as a USB key, USB Floppy drive, or an USB CD ROM.

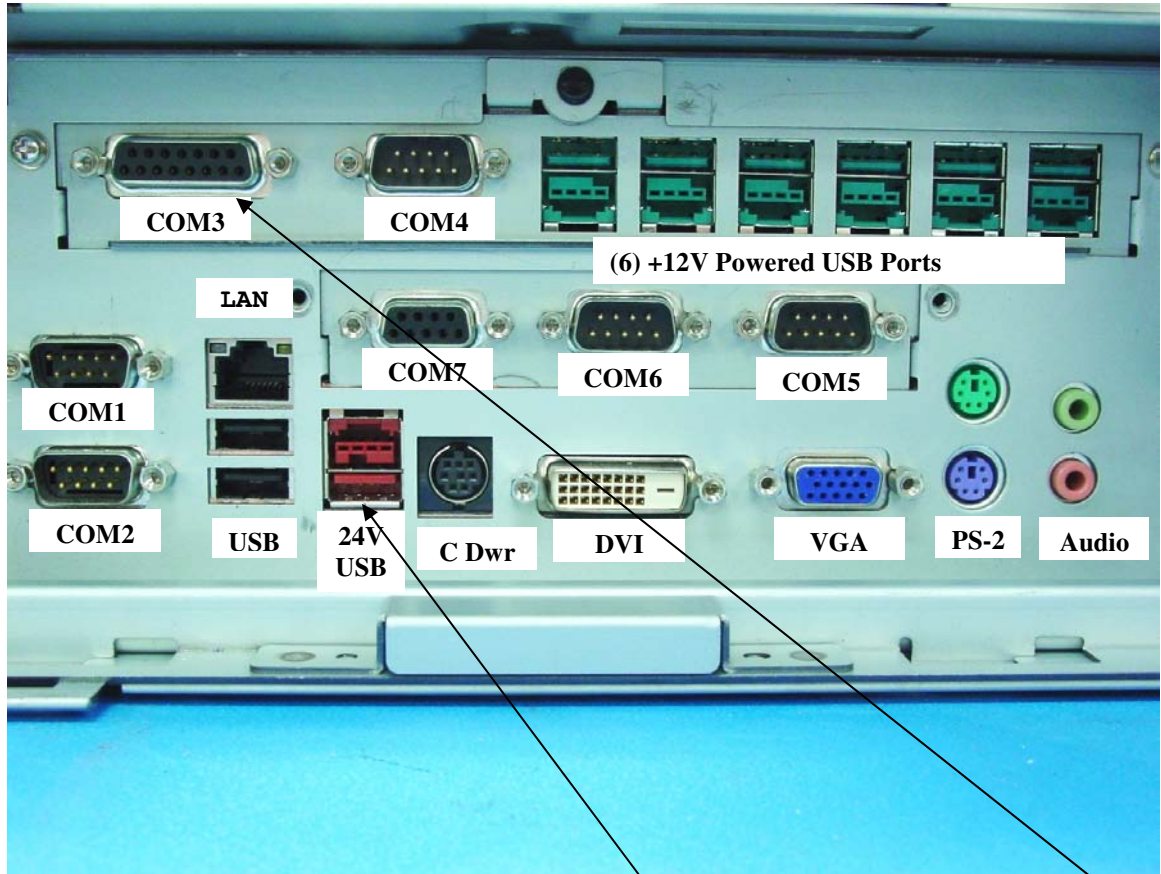

Note: Ports designated as Port “C” on the backplane (24V PUSB) and Port “3” on the Combo board(24V RS232) do not meet the UL Limited Power Source (LPS) requirements. These ports are limited to only allowing 24V retail POS RS232 or powered USB peripherals that do not exceed a rated current of 4 amps and are provided with a fire enclosure, rated Min. “V-1 or Metal”

Combo Card

The Combo card can be used by itself or with the XL motherboard a COM card can be added. It contains six +12V powered USB ports, a DB9 - RS232 port (COM 4), and a DB15 connector for a +24V powered printer (COM 3). A detailed description with Jumpers and pin outs can be found in Appendix C. When using the Combo card with the XL² motherboard one powered USB port is disabled (the port closest to the DB9 connector).



Note: Ports designated as Port “C” on the backplane (24V PUSB) and Port “3” on the Combo board(24V RS232) do not meet the UL Limited Power Source (LPS) requirements. These ports are limited to only allowing 24V retail POS RS232 or powered USB peripherals that do not exceed a rated current of 4 amps and are provided with a fire enclosure, rated Min. “V-1 or Metal”

COM Card

The COM card contains three RS232 ports that are configured as COM 5, 6, and 7. This board can only be used with the XL motherboard. The XL² motherboard does not support this card. These ports can be configured with power by jumper settings on the board. A picture of the board is seen below and a detailed description with jumpers and pin outs can be found in Appendix C.

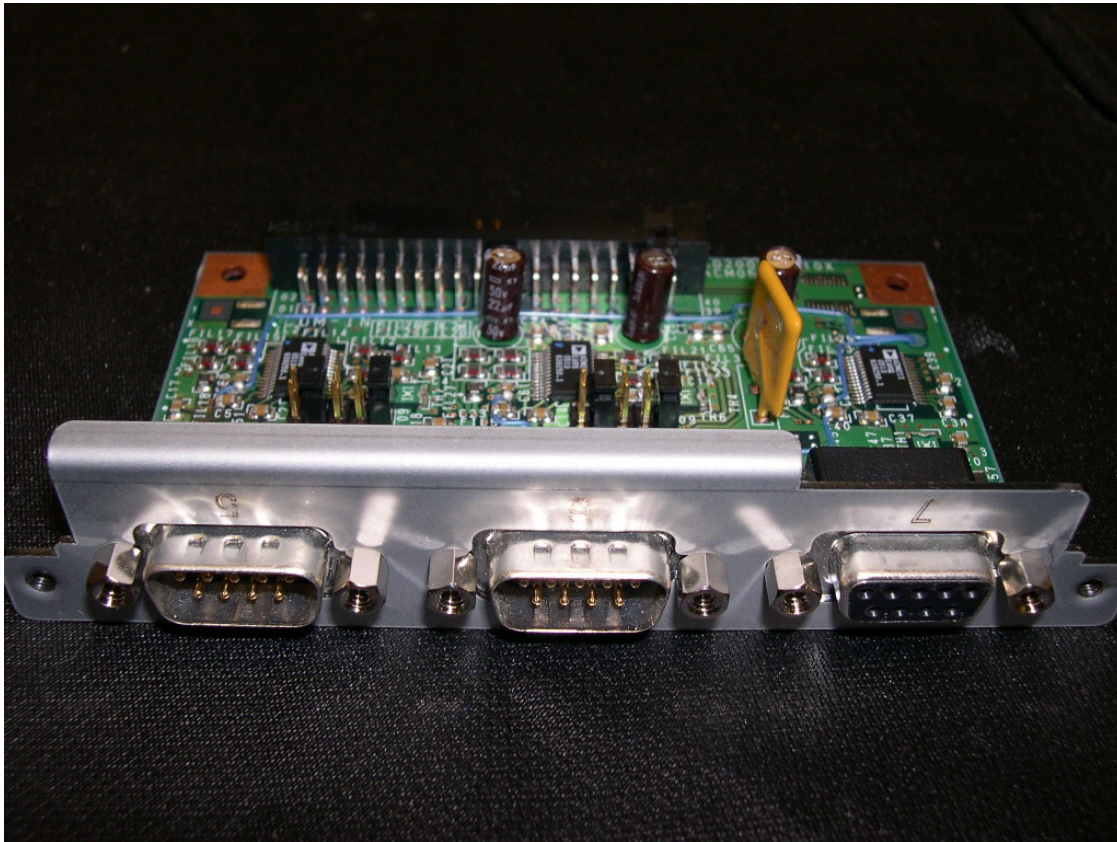

1.4.2.1. USB Card

The USB card can only be used as a stand alone card. It can not be used with any other I/O options. It contains three +12V powered USB ports. A picture of the board is seen below and a detailed description with jumpers and pin outs can be found in Appendix C.

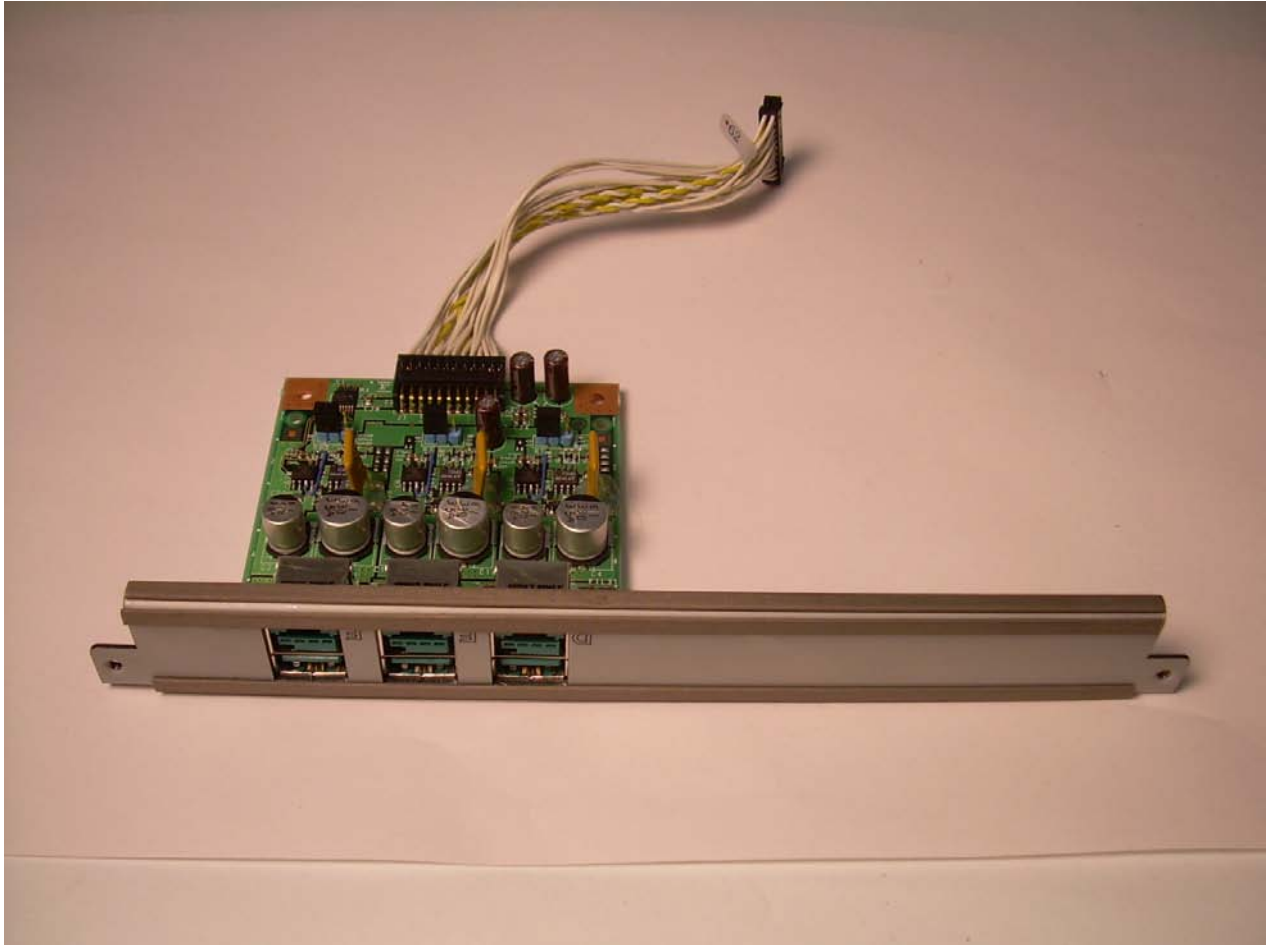

1.4.3. Front Operator Panel

The Operator panel on the TP3000 includes two 2.0 USB ports. There is a sliding switch on the operation panel that controls the power to the RS232 ports on the option cards. It takes 5 or more seconds before power is removed on the ports once the switch is turned off. It is recommended the switch be used during any RS232 peripheral exchange activity. The switch is “ON” in the right position and “OFF” in the left position. The front two USB ports can be used to boot from USB devices such as a USB key or USB floppy drive.

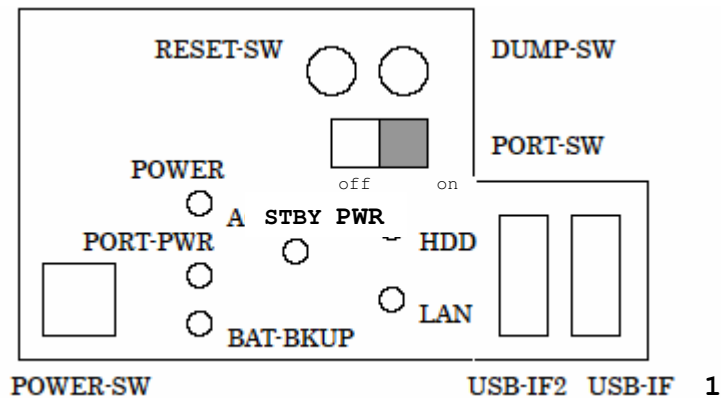

- RESET SWITCH – Causes the terminal to do a hard reboot. All data in memory will be lost and terminal will be forced to do a hard reboot.
- DUMP SWITCH – Not Used
- POWER LED – Indicates power is supplied to the power supply either through AC power or battery backup.
- PORT-SW: Default setting is “ON” (right position). Turns on/off power to RS232 ports.
- PORT-PWR - Indicates +24 and +5V power is on the printer and RS232 ports. Turning off the port-switch will cause this light to turn off after 5 or more seconds.
- STBY-PWR – Indicates +5V Standby power is supplied to the motherboard. Note: Do not remove motherboard from chassis when light is “ON” Unplug AC cord before removing motherboard.
- HDD – Hard Disk Drive activity light indicates when the hard drive/s is reading/writing.
- POWER-SW – Turns ON/OFF power to terminal. Can be set up in BIOS for soft shutdown (stops Windows in orderly shutdown) after being pressed, or hard shutdown (powers down regardless of activity) after pressing and holding switch for five seconds.
- BAT-BKUP – Indicates terminal is running on battery backup when “ON”
- LAN – Indicates activity on the LAN when lit
- USB-IF2 & IF – USB ports with +5V power supplied when AC power light is “ON”. However, if a flash card is installed, only USB-IF1 port is available for use. The other port will be blocked off and used for the internal flash card.

	Fujitsu Transaction Solutions	SUPPORT PLANNING GUIDE TeamPoS 3000 XL Terminal	SPG-06-002A
	Sustaining Engineering		Issue: 2.0
	San Diego, CA; Montreal QC		April 23, 2008

1.4.4. Power Supply Unit (PSU)

The power supply is internal to the control unit. It provides power to the control unit and peripherals and is located on the docking backplane platform. The DC output power is 270 watts maximum for PC board and I/O board functions.

1.4.5. Batteries

Aside from the lithium battery on the motherboard for CMOS memory, there are two basic battery backup options available:

- 1.) Partial Battery Backup
- 2.) Full System Battery Backup

Option #1 The lead acid battery is optional. It provides reserve power for control unit operation. Once the battery is fully charged and activated by the application software, the motherboard can continue to operate for up to 5 minutes after loss of AC power. The actual time is dependent upon the amount of memory, disk options, and CPU chip installed on the motherboard. **The battery backup does not provide power to the peripherals during a power failure.** Only a full battery backup pack installed will provide full backup power during a power failure. When building AC power is unavailable, the transaction in process is protected and the Ethernet LAN or modem communications continue to operate.

The application software is notified whenever the PC board is operating on battery power. The application software can then take appropriate actions to minimize the risk of exceeding reserve power limits by performing an orderly shutdown.

For most AC power failures which last less than 2 minutes, the application will monitor the power situation but take no action and when power is restored the current transaction can continue without any loss of data. For the rare power failures that last for several minutes, the application software can store the transaction data on the terminal's hard disk, if installed, or upload the data to the battery backed-up server, along with other information. If power isn't restored in a predetermined length of time, the application software can perform an orderly shutdown of the terminal. When power is restored, the transaction can then continue.

The TP3000 lead-acid battery is fused and does not require the battery to be disconnected during shipping although it is shipped disconnected and must be connected at install. The lead acid battery can easily be replaced once the front panel is removed.

Option #2 A full system battery backup will provide the terminal and peripherals with power for approximately 15 minutes, depending upon the charge state and the age of the batteries. During this time full POS operations can continue until power is restored or the application software can perform an orderly shutdown of the terminal after a predetermined length of time.

1.4.6. Disk Drives

Up to two Serial ATA hard disk drives can be installed in the TP3000 terminal. This can be configured as a Raid 1 or Raid 0. Factory defaults are RAIN even if there is only one disk installed. Adding a second drive then provides RAID capability. The exception to this is Windows 2000 which does not support RAID.

1.4.7. CD-ROM

There are two types of CD-ROM's available, the standard read-only CD-ROM, and the Read/Write CD/DVD ROM. CD-ROM's can be used for initial program loading and set-up, diagnostics, any other purposes dictated by the application program as well as multi-media applications. Upon a loss of power, the CD-ROM will continue to operate from power provided by the lead acid battery (if installed).

1.5. SPECIFICATIONS

1.5.1.1. Controller Specifications

Features		XL Type	Remark
Card	ISA	No	
	PCI	1 slot (low profile only)	
	AGP	No	
File Bay	2.5" Bay -1	Primary HDD or Flash Disk	Serial ATA
	2.5" Bay -2	Secondary HDD	Serial ATA
	3.5" Bay-1	No	
	5.25" Bay	1 x (half height)	Thin CD-ROM/Combo Drive
	Others	Mini-PCI	
Power Supply	Input	100-240V, 50/60 Hz	
	AC Inlet	IEC connector	
	Output power	270W	
	Control I/F	ATX + I2C + GPIO	(Without -5V, -12V)
	Limitation of +12V output	9.5A	
	Limitation of +24V output	1.8A	
	AC Outlet	No	
	ACPI compliant	Yes	
	Energy Star	Yes	
Battery backup	Yes (optional)		
Partial Backup (3 yr or 6 yr)	Battery type	Lead battery	2 Different Batteries Available
	Backup time	50W, 5min	
	Control I/F	ATX + I2C + GPIO	(Without -5V, -12V)
	Backup unit	Controller, TP, KB, USB(+5V)	
	Battery life	3 years or 6 years	
	Storage condition	Charge every 6 months	
	Battery backup	Yes (optional)	
Full Battery Backup	Battery type	Lead Acid Battery	On Standard Chassis Only
	Backup time	15 minutes (typical)	
	Control I/F	ATX + I2C + GPIO	(Without -5V, -12V)
	Backup unit	Full backup	
	Battery life	3 years	
	Storage condition	Charge every 6 months	
Operator Panel & Misc.	Power SW	Yes	
	Reset SW	Yes	
	Dump SW	Disabled	
	COM Port Off SW	Yes	
	HDD select SW	No	Supported by BIOS.
	Power LED	Yes	Amber color LED
	COM Port Power LED	Yes	Yellow color LED
	Battery backup LED	Yes	Green color LED
	HDD Access LED	Yes	Green color LED
	LAN Activity LED	Yes	Green color LED
	USB Interface LED	No	
	USB Connector	2 ports on Operator Panel	+2 USB Ports on rear
	Speaker	No	Speaker is on LCD
Enclosure	Dimension (Compact Chassis only)	340(W)x370(D)x105(H)	Without rear cover
		340(W)x450(D)x105(H)	With rear cover
	Color	White or Black	
	Texture	Deep texture by double etching method	

Features		XL Type	Remark
	Material	Metal & plastics	
	Front door key lock	Yes	Protected USB port and optical drive
	Spill & Dust	Yes	
Safety & Regulatory	UL/CSA	Yes	
	CE/CB	Yes	
	FCC/VCCI	Class-A	GB4943-2001
Manufacture & Maintenance	Max time to replace major components	Less than 5 min	
	Test time	Less than 15 min	
	Clearly label jumpers & switches	Basically there is no hardware setting. (To use Software setting) Label or Marking is attached, if hardware setting is needed.	
	Front access unit	2 x HDD units & Motherboard	TBD
	Identify rear panel connectors by color	Yes	

1.5.1.2. Power Supply

Item		Description		
Input Voltage		100-240VAC, Single Phase, 47-63 Hz		
Output Voltage		DC	Continuous	Rated
		+3.3V	4.0A	0.1~4.0 Amps
		+5VB	15.0A	0.1~15.0 Amps
		+5V SB	1.0A	0.1~1.0 Amps
		+12V	9.5A	0~9.5 Amps
		+24V	5.0A @ 3 Min	
			3.0A @ 20 Min	
	1.8A @ Load Not Printing			
Temperature	Operating	0 to 40 degrees C		
	Not Operating	-5 to 60 degrees C		
Humidity	Operating	10% RH to 95% RH		
	Not Operating	5% RH to 95% RH		
Shock		Able to withstand drop from 50mm three times		
Vibration		0.5G (5Hz to 60HZ) for 1 Hour x/y/z direction		

	Fujitsu Transaction Solutions	SUPPORT PLANNING GUIDE TeamPoS 3000 XL Terminal	SPG-06-002A
	Sustaining Engineering		Issue: 2.0
	San Diego, CA; Montreal QC		April 23, 2008

1.6. PERIPHERALS

TeamPoS 3000 offers a large assortment of peripherals. Many are color and style compatible with the TeamPoS 3000 control unit and they can be stacked on the control unit and/or cash drawer to form an integrated unit.

1.6.1. Printers

Numerous printers have been validated and are supported:

- Epson Models DT50IIT (TranScan), DT50III, and TM-T88IV
- TPG (Axiohm) A758
- Model CT10

Other models are being validated and supported as the product is released. Later versions of this SPG will contain a more extensive list of printers that are supported.

1.6.2. Keyboards

Three keyboards have been validated and are available for use on the TeamPoS 3000.

- 92U Keyboard
- 133UQ Keyboard
- 133AU Keyboard
- 104P Keyboard

1.6.3. Displays

There are a number of TeamPoS 3000 display options, listed below are the most common.

- VF60, 2 line X 20 characters vacuum fluorescent display with +12 volt powered USB interface
- D22, 12.1" TFT LCD Display (Options: Resistive touch, keypad, and MSR)
- D25, 15" TFT LCD Display (Options: Resistive or IR touch, keypad, and MSR)

1.6.3.1. VF60 Display

The Model VF60 is similar to the VF50U in that both use vacuum fluorescent technology. Each character is formed by a 5 (wide) x 7 (high) dot matrix. There are actually 8 dots usable in the height of the display, but only 7 are used to display characters, the remaining dot is used for underlining and commas. The display is capable of displaying 2 lines of 20 characters each. The VF60 is supplied signal and power through a +12V powered USB connector to the TeamPoS 3000 terminal.

Summary of Model VF60 specifications:

Technology	Vacuum Fluorescent
Interface	USB 1.1 /can communicate with USB interface 2.0
Display Color	Blue-green
Lines	2
Characters per line	20
Fonts	5(W) x 8(H) Dot Matrix
Character size	6.5mm x 11.4mm
Rotation	Horizontal: 330° Vertical: 30°
Dimensions (mm)	245(W) X 100(H) X 39.5(D)
Cables	0.85 meters (stacked), 1.5 meters and 4.0 meters (dispersed)
Average current	0.480 amps @ 12 VDC
Max current	0.600 amps @ 12 VDC
Luminance Min	350 cd/m ²
Luminance Typical	700 cd/m ²

	Fujitsu Transaction Solutions	SUPPORT PLANNING GUIDE TeamPoS 3000 XL Terminal	SPG-06-002A
	Sustaining Engineering		Issue: 2.0
	San Diego, CA; Montreal QC		April 23, 2008

1.6.3.2. D22 – 12.1” LCD

The D22 display is a 12.1” LCD being introduced with the TeamPoS 3000 terminal. It is available in either white or black and can be ordered with or without resistive touch screens. The display can be powered by one of the +12V powered USB ports on the back of the terminal or with the use of an external power brick.

The D22 can be configured as either an analog or DVI display depending upon the cable used. Options include Resistive touch, keypad with MSR, and MSR only. The picture below shows the stacked D22 configured with the TeamPoS 3000 terminal



D22 LCD Specifications:

- 12.1” TFT Panel Backlight, with a Max resolution 800 X 600
- VESA Compliant Mounting for Opt Integrated or Dispersed stands or Wall Mount Operates on +12V \pm 5% power at a max of 450ma
- Interface = Analog and DVI
- Support Options (Touch, Keypad/MSR or MSR only)
- Signal/Power LED Indicator
- Optional Resistive Touch Screen
- Brightness = 250 cd/m² Min (without touch)
- Brightness = 200 cd/m² Min (with touch)
- Contrast Ratio = 250:1 Min
- Colors = 262,000
- Weight = 2.57Kg \pm 50g (5.65 lbs.)
- Audio Speakers with 1.5 watt max per channel audio output
- Slide switch for selecting primary and secondary touch panels is found on the rear of the display housing. This was used in the early Fujitsu touch panels, but is no longer needed/functional in the ELO touch panels
- Operator controls - Adjustments for Volume, Contrast and auto adjust button

	Fujitsu Transaction Solutions	SUPPORT PLANNING GUIDE TeamPoS 3000 XL Terminal	SPG-06-002A
	Sustaining Engineering		Issue: 2.0
	San Diego, CA; Montreal QC		April 23, 2008

1.6.3.3. D25 – 15” LCD

The D25 is a 15” LCD introduced around the same time frame as the TeamPoS 3000 terminal.

It is available in either white or black and can be ordered with two different types of touch screens (resistive or IR). The display can be powered by one of the +12V powered USB ports on the back of the terminal or with the use of an external power brick.

The D25 can be configured as an analog or DVI display depending upon the cable used. The picture on page 8 shows the stacked D25 configured with the TeamPoS 3000 terminal.

D25 LCD Specifications:

- 15” TFT Panel Backlight, with a Max resolution 1024 x 768
- VESA Compliant Mounting for Opt Integrated or Dispersed stands or Wall Mount (requires in counter mounting kit)
- Operates on +12V \pm 5% power at a max of 1.5 amps
- Interface = Analog and DVI
- Support Options (Touch, Keypad/MSR or MSR only)
- Signal/Power LED Indicator
- Optional Resistive or IR Touch Screens
- Brightness = 250 cd/m2 Min (without touch)
- Brightness = 200 cd/m2 Min (with touch)
- Contrast Ratio = 500 to 1 Min
- Colors = 262,000
- Weight = 4.05 Kg (8.9 lbs)
- Audio Speakers with 1.5 watt max per channel audio output
- Slide switch for selecting primary and secondary touch panels. This was used in the early Fujitsu touch panels, but is no longer needed/functional in the ELO touch panels
- Operator controls - Adjustments for Volume, Contrast, and auto adjust button
- Operating Temperature = 0°C to 50°C
- Relative Humidity = 5% to 95%

1.6.4. Cash Drawers

The TP15 cash drawer is the only approved cash drawer that plugs directly into the docking backplane. Other cash drawers can be used in conjunction with a printer; where the printer actually fires the cash drawer.

The TP15 cash drawer can be ordered in the standard model or compact model depending upon the terminal being used. There are two color options, (white or black) and the cash drawer can be purchased with or without a keylock.

The picture below shows the black TP15 cash drawer.



1.7. PRODUCT PERFORMANCE

1.7.1. RELIABILITY

Appendix A contains a work sheet for calculating the anticipated failure rate of a typical customer installation.

Description	MTBF	MEASURE
Controller		
Motherboards (Both XL and XL ²)	100,000	POH
Docking Platform	100,000	POH
Combo I/O Board	767,795	POH
COM I/O Board	1,845,188	POH
Powered USB I/O Board	2,147,720	POH
CPU (All CPU's)	10,000,000	POH
HDD Unit	300,000	POH
HDD Unit-number of load & unload cycles	600,000	POH
CD-ROM Unit (Duty 10%)	60,000	POH
CD-RW/DVD (Duty 10%)	60,000	POH
PSU	100,000	POH
PSU Fan @ 25°C (failure at 90% rotation speed)	150,000	POH
Control Panel	2,984,000	POH
256 MB DDR DIMM (XL Motherboard)	18,518,519	POH
512 MB DDR DIMM (XL Motherboard)	37,037,038	POH
1 GB DDR DIMM (XL Motherboard)	18,518,519	POH
512 MB DDR2 SO-DIMM (XL ² Motherboard)	11,111,111	POH
1.0 GB DDR2 SO-DIMM (XL ² Motherboard)	11,111,111	POH
2.0 GB DDR2 SO-DIMM (XL ² Motherboard)	5,882,353	POH
Printers		
CT10 (Monochrome)	20,000,000	Lines Printed
CT10 – Cutter (75um thick paper)	2,000,000	# Cuts
CT10 (MTBF using recommended thermal paper)	>360,000	Hours
DT50/DT50II/DT50III – Receipt Printer	15,000,000	Lines Printed
DT50/DT50II/DT50III – Endorsement Printer	1,350,000	Lines Printed
DT50IIT/DT50IIIT – Image Scanning Mechanism	240,000	Scanned Images
DT50/DT50II/DT50IIT/DT50III – Auto Cutter	1,500,000	# Cuts
Keyboards		
133UQ	170,000	POH
133UQ	10,000,000	Strokes/Key
133UQ – MSR	>300,000	Swipes
133AU	Same as the UQ	
92U	200,000	POH
92U	20,000,000	Strokes/Key
40 TeamKey/MSR	10,000,000	Strokes/Key
32 Key Keypad/MSR	10,000,000	Strokes/Key

Displays		
D22 - 12" LCD Backlight	50,000	POH
D22 Resistive Touch Panel	35,000,000	Touches
D25 - 15" LCD Backlight	50,000	POH
D25 - 15" LCD Resistive Touch Panel	35,000,000	Touches
D25 - 15" LCD IR Touch Panel (technology rated in Hours not Touches)	100,000	POH
D15 LCD PWB	90,000	POH
D15 CCFL Backlight	50,000	POH
D15 Touch Controller	74,000	POH
D15 Touch Panel (Resistive)	35,000,000	Touches
D15 Touch Panel (Capacitive)	35,000,000	Touches
D15 Optional Keypad - Controller PWB	100,000	POH
D15 Optional 3 track MSR	500,000	Swipes
2 x 20 VF60U Unit	100,000	POH
D25 Optional 3 track MSR	500,000	Swipes
Cash Drawers (Typically)		
TP15	500,000	Opens/Closes

1.7.2. LIFE EXPECTANCY

The design life expectancy for the TeamPoS 3000 Terminal components are as follows.

Description	Life
HDD Unit (Note 2)	>5 years at normal conditions
PSU FAN (Note 3)	>150,000 hours
CD-ROM drive unit	9,000 hours laser life 10,000 times loading of disk tray 2,000,000 seeks- feed motor life
Lithium Battery	>10 years
Lead Acid Battery - 3 Year (Partial Backup)	>3 years
Lead Acid Battery - 6 Year (Partial Backup)	>6 years
Lead Acid Battery - 3 Year (Full Backup)	>3 years
CT10 Print head of single station printer	200,000,000 characters
VF60	30000 hours
LCD Backlight Panel Life (Note 4)	>50,000 hours (half brightness)
Touch Panel (D22 & D25 Resistive)	>35 million touches
TP15 Drawer Open (Standard Drawer)	>500,000 open & closes
TP15 Drawer Open (Compact Drawer)	>500,000 open & closes

Notes:

- 1) The temperature condition is 25°C/77°F.
- 2) The life span will be reduced if the drive is running constantly 24 hours a day.
- 3) The life span is defined as maintaining 90% of specific rotation speed at 25°C/77°F.
- 4) The life span is defined as maintaining 50% of specific brightness.
- 5) The MSR head cleaning per regular maintenance.

	Fujitsu Transaction Solutions	SUPPORT PLANNING GUIDE TeamPoS 3000 XL Terminal	SPG-06-002A
	Sustaining Engineering		Issue: 2.0
	San Diego, CA; Montreal QC		April 23, 2008

2. RESOURCES

The following sections list support, training, documentation, spares, repairs, and diagnostics available for the TeamPoS 3000.

2.1. SKILLS REQUIRED

Customer Service Representative:

A good working knowledge of Intel-based PC components, POS peripherals, I/O card installation and supported operating systems is required. Prior experience and knowledge of POS terminals and their associated peripherals, Confidence Level Diagnostics (CLD), and commercial off-the-shelf PC diagnostics is assumed.

Consultant/Project Manager:

Good working knowledge of PCs, supported operating systems, and specific application experience is assumed.

Repair Center Technician:

An in-depth understanding of Intel-based PC components, POS peripherals, I/O cards, and supported operating systems is required. Knowledge of Confidence Level Diagnostics (CLD) and commercial off-the-shelf PC diagnostics is assumed.

Experience with troubleshooting multilayer PWAs, including surface mount technology (SMT) is required.

2.2. TRAINING

Field Service training is under the discretion of each specific business unit. Sustaining Engineering will provide 'train the trainer' operations. The schedule and funding for training will be established on an individual case by case basis. All requests for training by Sustaining Engineering should be forwarded to the Sustaining Mailbox (reference the cover page).

Sustaining Engineering estimates that the Technical Publications listed are adequate for this product and additional training will not be necessary for Field Service personnel currently trained on similar Fujitsu products. The TeamPoS 3000 should be included in any future standard training provided to Fujitsu Field Service personnel.

2.3. TECHNICAL PUBLICATIONS

Description	Part Number
Software Support and Downloads	http://www.fujitsu.com/us/support/index.html
Installation and Maintenance Manual	D900000145
Intelligent PIN Document	11001599

2.4. SPARES

The TeamPoS 3000 is a Fujitsu product and will follow standard spares lead times. It is assumed that organizations will spare the TeamPoS 3000 at the FRU level. Some customers/organizations however, may choose to spare the major assembly level with the lower level repair performed at a central repair center or depot. The spares list takes both of these methods into consideration. Spares will be stocked at the North America Logistics Center (Frisco, USA24) and whole units should be returned on a RMA to the Logistics Center.

Refer to the Installation and Maintenance Manual for spare part information.

2.5. REPAIR

North America Logistics Center (Frisco) offers repair services for the items they consider to be repairable. The OEM vendor also offers repair services that may be contracted by one of these repair centers or other organizations.

Logistics and Field Service organizations should utilize their own services to provide a test of units being returned from the field before shipment to repair centers as history has shown that not all units being returned from the field are actually faulty.

If faulty, logistics organizations may elect to have the repair done down to a component level replacement if parts and resources permit. However, this would be a local decision.

2.5.1. FIELD REPAIR TIME

The following are time estimates for removing and replacing major assemblies on site. These time estimates do not include the time to diagnose the problem, gain clear access to the TeamPoS 3000, or perform any software reloading to return the unit to full customer functionality. It is assumed that this service is performed by a qualified and trained FE.

Description	Replacement Time (min)
Power Supply Unit	8 min.
Power Supply Fan	5 min.
Motherboard (Includes time to replace CPU and memory)	4 min.
Combo Board	4 min
COM Board	5 min
USB Board	4 min.
HDD unit	1 min.
Memory	1 min.
CD-ROM unit	4 min.
Front Cover	0.5 min.
Back Cover	0.2 min.
CPU & Heatsink	3 min.
Docking Backplane	13 min.
Control Panel	3 min.
Full Battery Backup Pack	3 min.
Battery	2 min.
Average MTTR for Complete Unit	5 min.

Average MTTR for the Complete Unit is based upon these times and adjusted by the probability of a specific component failing.

	Fujitsu Transaction Solutions	SUPPORT PLANNING GUIDE TeamPoS 3000 XL Terminal	SPG-06-002A
	Sustaining Engineering		Issue: 2.0
	San Diego, CA; Montreal QC		April 23, 2008

2.6. TOOLS

Only a medium size Phillips head screwdriver is required to access most replaceable units. A small flat head screwdriver is also required to replace the CPU.

2.6.1. DIAGNOSTICS

Two levels of diagnostics are provided.

- The first level consists of POST (Power-On Self Test) diagnostics, which are executed at power-on and test basic operations of the PC Motherboard.
- Windows Confidence Level Diagnostics (WINCLD) is the second level of diagnostics. CLD is a Windows based utility that allows a service engineer to identify POS problems to the ORU by performing Loopback tests on the RS232 and powered USB ports and exercising the POS peripherals that are attached. Specific instructions for executing WINCLD can be found along with the latest version of WINCLD on the Internet FTP site.

Note: WINCLD needs OPOS loaded

Diagnostics for testing of the PC portion of the TeamPoS is accomplished via a commercially available diagnostic program. QA Plus is the diagnostic certified and recommended by Fujitsu. It can be obtained at a local computer sales facility. Future PC diagnostics software will be accessible on the hard disk.

2.6.2. SERVICE TOOLS

The following is a list of test/repair tools needed:

- CLD-XPe-3KXL/XT 855/965 WIN CLD Kit – Includes the following:
 - IMG-XPE-3KXL/XT855/965 XPe Image
 - 90001601 USB Flash Drive drive,2.0G
 - 90001540 +12V Powered USB Loopback Plug (used with WINCLD)
 - 90001541 +24V Powered USB Loopback Plug (used with WINCLD)
 - G80-00007 XP Embedded License only
 - G80-00008 XP Embedded COA Sticker
 - 80203279 Loopback Plug, D9 Female
 - 80203280 Loopback Plug D15 Male
 - 80203084 Loopback Plug D9 Male
- 7737171 MSR Cleaner Cards
- 80064971 MSR Test Cards
- Small Phillips head screwdriver
- Small flat head screwdriver

	Fujitsu Transaction Solutions	SUPPORT PLANNING GUIDE TeamPoS 3000 XL Terminal	SPG-06-002A
	Sustaining Engineering		Issue: 2.0
	San Diego, CA; Montreal QC		April 23, 2008

3. SERVICE PROFILES

3.1. PREVENTATIVE MAINTENANCE

Beyond general cleaning of the TeamPoS 3000, there is no scheduled preventative maintenance required. However, if the environment contains a high amount of dust particles, the terminal may need to have the fan vents cleaned about every six months. If a lead acid battery is installed, it should be replaced every 3/6 years depending upon the battery installed to ensure proper battery back-up.

The life cycle for the Lithium Battery is more than 10 years and the Lead Acid Battery is more than 3 years.

General cleaning of the terminal, peripherals, and MSR is required on a regular basis. These procedures are described in the Installation and Maintenance Manual and are the responsibility of the customer. In particular, dust must be removed from internal components, air vents, fans, and exhaust screens to allow sufficient air flow to maintain proper cooling. Printers must also have paper dust/scraps removed regularly to maintain proper printer operation. The frequency of this cleaning will depend upon installed environments. Lack of this cleaning will greatly reduce equipment reliability. To achieve the MTBF for the MSR, cleaning with a MSR cleaner card must be performed approximately every 1,000 passes.

See Installation and Maintenance Manual for Specifications

3.2. CORRECTIVE MAINTENANCE

In the event of a failure the customer should be expected to confirm the malfunction by carrying out his or her own internal problem resolution procedures. If their procedures are unable to resolve the problem, they should contact their local Field Service/Support organization.

Field Service/Support organizations should provide a support desk facility whereby customers can telephone for advice before logging a service request. If telephone assistance is unable to resolve the problem, the local Field Service/Support organization should send a representative to assist, unless no maintenance agreement was selected. Field Service/Support should affect on-site repairs to the FRU level recommended by their Field Service/Logistics management.

3.3. ESCALATION PROCEDURES

The escalation of product error reports or requests for assistance should take place in the following order. While some of these steps may be in the same organization, they are listed as individual steps to illustrate the 'functional' process flow.

Customer's Internal Service

First Line Support Service (Help Desk)

Field Service Organization

Field or Local Technical Support (FTS)

National Technical Support (NTS)

Sustaining Engineering

Development/Supplier Engineering – with Mgmt Escalation

Product reports raised on supported products or general inquiries should be sent to the Sustaining mailbox (reference the cover page).

4. APPENDIX A: FAILURE PER YEAR WORKSHEET

The following are specific variables that need to be determined for your specific customer configuration when calculating Failures Per Year (FPY).

Description	Variables
Avg. Power On Hours per Year (8736 max)	(A) _____
Avg. 'Green Mode' Power On Hours per Year	(B) _____
Avg. Transactions per Trading Hour	(C) _____
Avg. Trading Hours per day	(D) _____
Avg. Trading Days per Week	(E) _____
Avg. Keystrokes per Transaction	(F) _____
Avg. Keylock Cycles per Transaction	(G) _____
Avg. MSR Usage's per Transaction (1 out of 3=.33)	(H) _____
Avg. Print Lines per Transaction	(I) _____
Avg. Cash Drawer Openings per Transaction	(J) _____
Avg. Transaction per Terminal Year (C*D*E*52wks)	(K) _____

Units Affected by Power On Hours:

Device	Power On Hours	/ MTBF Hours	=	FPY
*	(A) _____ /	*	=	_____
*	(A) _____ /	*	=	_____
*	(A) _____ /	*	=	_____
*	(A) _____ /	*	=	_____
*	(A) _____ /	*	=	_____
Power On Total				_____

Units Affected by Green Mode Operational Hours:

Device	Power On Hours	/ MTBF Hours	=	FPY
*	(B) _____ /	*	=	_____
*	(B) _____ /	*	=	_____
*	(B) _____ /	*	=	_____
*	(B) _____ /	*	=	_____
*	(B) _____ /	*	=	_____
Green Mode Total				_____

Units Affected by Mechanical Usage:

Keyboard:	(F) x (K) / *	=	_____	
Keylock:	(G) x (K) / *	=	_____	
MSR:	(H) x (K) / *	=	_____	
Printer:	(I) x (K) / *	=	_____	
Cash Drawer:	(J) x (K) / *	=	_____	
Mechanical Total				_____

Total for your customer configuration (per lane):

Power On Total	_____
Green Mode Total	_____
Mechanical Total	_____
Total FPY Per Lane	_____

Note: This total does not include failures resulting from use of consumables (batteries, print heads, etc.), cables, software/firmware based problems, no-fault-founds, or resulting from use not considered standard for this type of equipment.

5. APPENDIX B: MOTHERBOARDS

XL Motherboard (11000021)

The following illustrations show the TeamPoS 3000 XL Motherboard with the position of the jumper settings. Explanation and default setting (**Bolded**) are provided on the following pages. When installing or exchanging the main board, be sure the settings are adjusted accordingly.

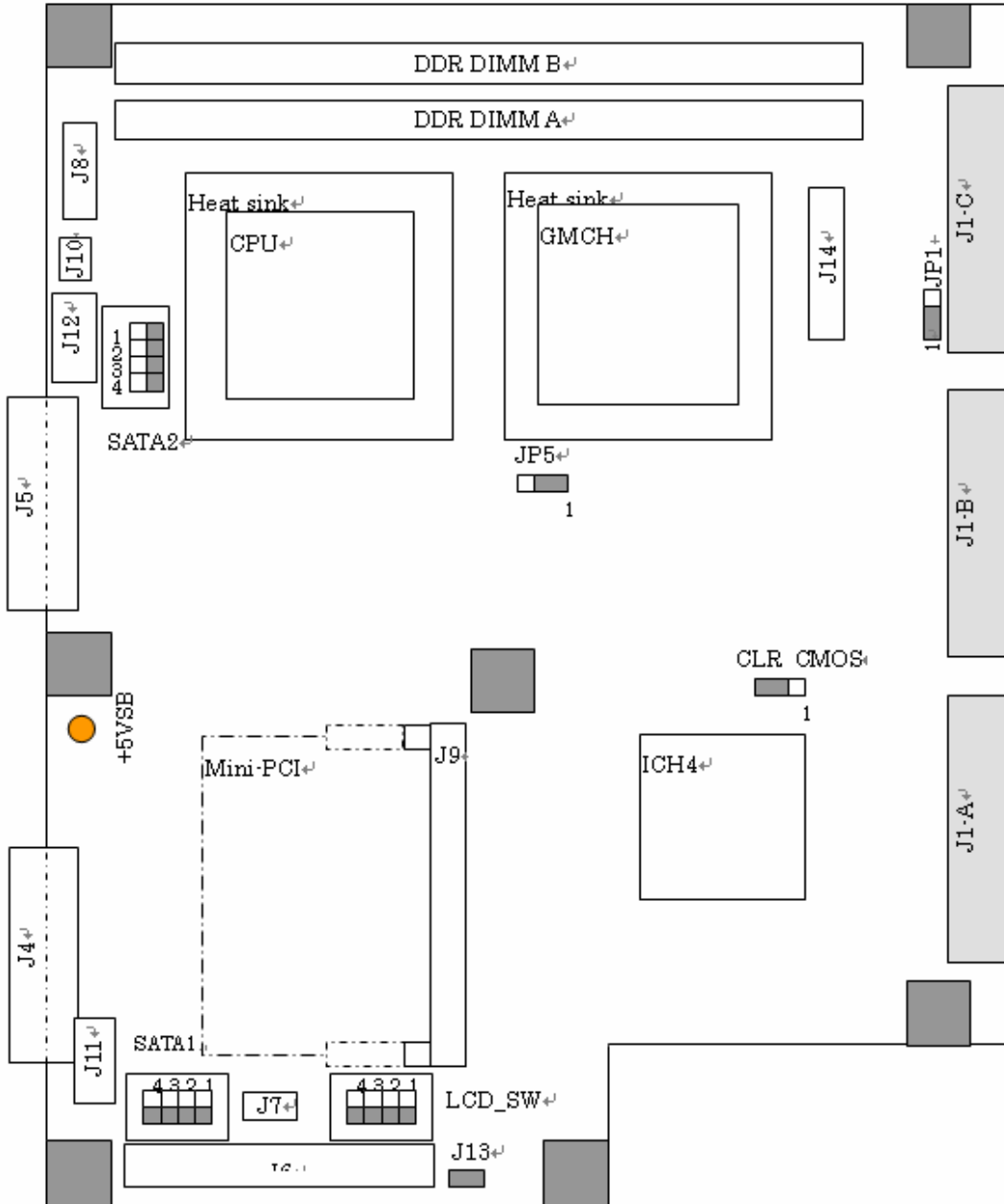

Switch and Jumper settings on the TP3000 XL motherboard

Setting Pin#	Function	Default Setting																														
JP1	Video source selection of 1st display 1-2 DVI Interface (for M/M) 2-3 LVDS Interface (for KIOSK)	1-2																														
JP5	VCCA voltage selection 1-2 VCCA is 1.8V for PentiumM and CeleronM, FSB 400MHz 2-3 VCCA is 1.5V for PentiumM, FSB 533MHz	1-2																														
J13	Beep sound enable Short Beep sound enable Open Beep sound disable	Short																														
CLR_CMOS	CMOS Clear 1-2 CMOS Clear 2-3 Normal	2-3																														
LCD_SW	Panel selection for LVDS panel <table border="1" style="width: 100%; border-collapse: collapse;"> <tr> <td style="width: 10%;">1</td> <td style="width: 10%;">2</td> <td style="width: 10%;">3</td> <td style="width: 10%;">4</td> <td style="width: 60%;">Panel</td> </tr> <tr> <td>OFF</td> <td>OFF</td> <td>OFF</td> <td>-</td> <td>12.1 inch SVGA</td> </tr> <tr> <td>ON</td> <td>OFF</td> <td>OFF</td> <td>-</td> <td>15 inch XGA</td> </tr> <tr> <td>OFF</td> <td>ON</td> <td>OFF</td> <td>-</td> <td>17 inch SXGA</td> </tr> <tr> <td>ON</td> <td>ON</td> <td>OFF</td> <td>-</td> <td>10.4 inch VGA</td> </tr> <tr> <td colspan="4">Other setting</td> <td>Reserved</td> </tr> </table>	1	2	3	4	Panel	OFF	OFF	OFF	-	12.1 inch SVGA	ON	OFF	OFF	-	15 inch XGA	OFF	ON	OFF	-	17 inch SXGA	ON	ON	OFF	-	10.4 inch VGA	Other setting				Reserved	1...OFF 2...OFF 3...OFF 4...OFF
1	2	3	4	Panel																												
OFF	OFF	OFF	-	12.1 inch SVGA																												
ON	OFF	OFF	-	15 inch XGA																												
OFF	ON	OFF	-	17 inch SXGA																												
ON	ON	OFF	-	10.4 inch VGA																												
Other setting				Reserved																												
SATA1	Connector selection of 1st SATA HDD <table border="1" style="width: 100%; border-collapse: collapse;"> <tr> <td style="width: 10%;">1</td> <td style="width: 10%;">2</td> <td style="width: 10%;">3</td> <td style="width: 10%;">4</td> <td style="width: 60%;">Panel</td> </tr> <tr> <td>ON</td> <td>ON</td> <td>ON</td> <td>ON</td> <td>J4 (for M/M)</td> </tr> <tr> <td>OFF</td> <td>OFF</td> <td>OFF</td> <td>OFF</td> <td>J11 (for KIOSK)</td> </tr> <tr> <td colspan="4">Other setting</td> <td>Prohibited</td> </tr> </table>	1	2	3	4	Panel	ON	ON	ON	ON	J4 (for M/M)	OFF	OFF	OFF	OFF	J11 (for KIOSK)	Other setting				Prohibited	1...OFF 2...OFF 3...OFF 4...OFF										
1	2	3	4	Panel																												
ON	ON	ON	ON	J4 (for M/M)																												
OFF	OFF	OFF	OFF	J11 (for KIOSK)																												
Other setting				Prohibited																												
SATA2	Connector selection of 2 nd SATA HDD <table border="1" style="width: 100%; border-collapse: collapse;"> <tr> <td style="width: 10%;">1</td> <td style="width: 10%;">2</td> <td style="width: 10%;">3</td> <td style="width: 10%;">4</td> <td style="width: 60%;">Panel</td> </tr> <tr> <td>ON</td> <td>ON</td> <td>ON</td> <td>ON</td> <td>J4 (for M/M)</td> </tr> <tr> <td>OFF</td> <td>OFF</td> <td>OFF</td> <td>OFF</td> <td>J11 (for KIOSK)</td> </tr> <tr> <td colspan="4">Other setting</td> <td>Prohibited</td> </tr> </table>	1	2	3	4	Panel	ON	ON	ON	ON	J4 (for M/M)	OFF	OFF	OFF	OFF	J11 (for KIOSK)	Other setting				Prohibited	1...OFF 2...OFF 3...OFF 4...OFF										
1	2	3	4	Panel																												
ON	ON	ON	ON	J4 (for M/M)																												
OFF	OFF	OFF	OFF	J11 (for KIOSK)																												
Other setting				Prohibited																												

XL

TP3000 Motherboard

SATA2 SW

1	2	3	4	Panel
ON	ON	ON	ON	J4 (for M/M)
OFF	OFF	OFF	OFF	J11 (fr KIOSK)
Other settings				Prohibited

JP1 Video Source Selection 1st Disp

1-2	DVI Interface (for M/M)
2-3	LVSD Interface (for KIOSK)

JP5 VCCA Voltage Selection

1-2	VCCA = 1.8V 400MHz FSB
2-3	VCCA = 1.5V 533MHz FSB

CLR CMOS

1-2	CMOS Clear
2-3	Normal

JP3 IO Address
4E/4FH = High
2E/2FH = Low
Default = 2-3

JP4

SATA1 SW

1	2	3	4	Panel
ON	ON	ON	ON	J4 (for M/M)
OFF	OFF	OFF	OFF	J11 (fr KIOSK)
Other settings				Prohibited

BEEP Sound Enabl

Short	Enable
Open	Disable

LCD SW

1	2	3	4	
OFF	OFF	OFF	-	12.1" SVGA
ON	OFF	OFF	-	15" XGA
OFF	ON	OFF	-	17" SGA
ON	ON	OFF	-	10.42 VGA
Other setting				Prohibited

XL Motherboard Specifications

Features		XL Type	Comments
CPU		Pentium M 1.6GHz, 2.0GHz Celeron M 1.3GHz, 1.5GHz	Auto detection for FSB speed FSB 400MHz
Core Chipset		i855GME + ICH4	
System Memory	RAM slots	2 x 184 pins DIMM	
	Supported DRAM	2.5Volts DDR SDRAM 333	PC2700 Compliant
	DRAM capacity	256MB up to 2GB	
	DRAM ECC	Yes	
	L2 Cache	Depends on CPU	
	BIOS ROM	Flash (FWH type)	BIOS Up-Gradable from a file
	CMOS backup	On board Lithium battery	10 years, soldered w/o socket
Graphic & Video	Chipset	Integrated on North bridge	
	VRAM	UME (Max32MB)	
	Analog Interface	Yes	
	Digital I/F	LVDS (XT model) - DVI (XL model)	
	Displays	VGA/SVGA/XGA	
	Colors	16bit/32bit Color	
Sound/Audio	Controller	AC97 Compliant	
	Ext. Connector	Line OUT / MIC IN	
LAN	Interface	10Base-T/100BASE-TX	
	Controller	Integrated on South Bridge	
	Wake-On LAN	Yes(S1/S3/S4/S5 resume support)	
I/O	Front USB	2 ports	
	Rear USB	Max 9 ports	Depends on I/O Board Installed
	COM	Max 7 ports	Depends on I/O Board Installed
	Parallel	No	
	IrDA	No	
	Keyboard	PS/2	
	Mouse	PS/2	
	Floppy Disk I/F	No	
HDD	SATA	Up to 2 drives	
	Speed	1.5 Gbps	
	RAID	Yes (Raid 0 or Raid 1)	
IDE	Interface	Up to UDMA5	For CD/DVD
	Ports	Secondary	
	CD/DVD support	Yes	
Board Factor	Form factor	No standard	
	Riser card	No	
	AGP Slot	No	
Other features	Plug & Play	Yes	
	APM 1.2 Support	Yes	
	ACPI support	Yes	
	WFM1.1a support	Yes	Remote boot and Wake-On LAN
	DMI 2.0 Support	Yes	
	PC99 Compliant	Yes	
	AC Failure Restoration	Yes	
Safety/EMI	CE/CB	Yes	
	FCC	Class A	FCC 47CFR Part 15 class A
	CCC	Possible Future Approval	GB4943-2001

	Fujitsu Transaction Solutions	SUPPORT PLANNING GUIDE TeamPoS 3000 XL Terminal	SPG-06-002A
	Sustaining Engineering		Issue: 2.0
	San Diego, CA; Montreal QC		April 23, 2008

Features		XL Type	Comments
	UL/CSA	Yes	UL60950-1 1st Edition CAN/CSA-C22.2 No.60950-1-03 1st Edition
Reliability	MTBF	100,000 hours	
	HW- Monitoring	Yes	
	- CPU voltage	Yes	
	- CPU Thermal	Yes	
	- FAN Control	Yes	
	- FAN Rotation	Yes	
	- Chassis open	No	

XL² Motherboard (11001590)

The following illustrations show the TeamPoS 3000 XL² Motherboard with the position of the jumper settings. Explanation and default settings (**Bolded**) are provided on the following pages. When installing or exchanging the main board, be sure the settings are adjusted accordingly.

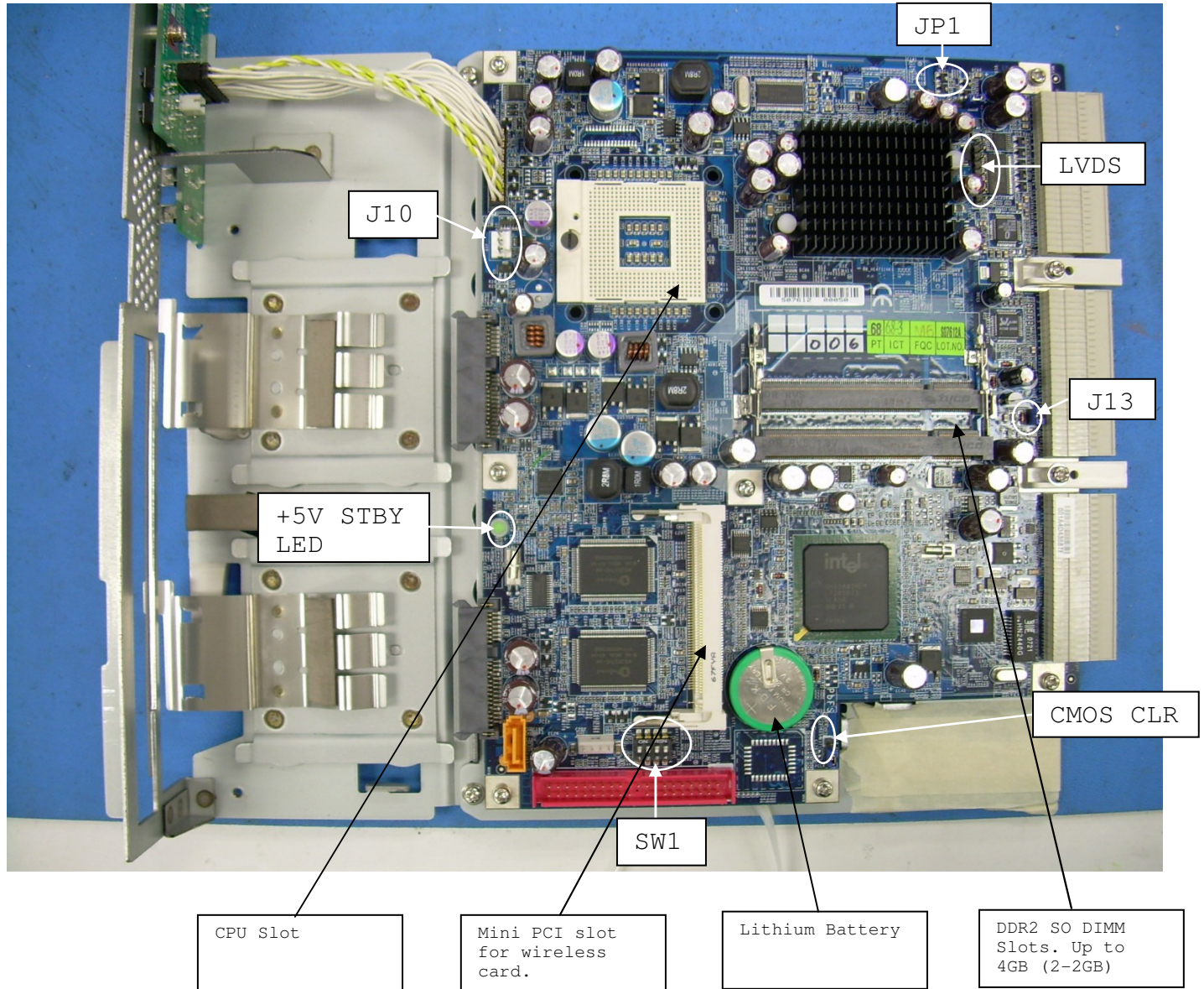

Switch and Jumper settings on the TP3000 XL² motherboard

Setting Pin#	Function	Default Setting																														
JP1	Video source selection of 1st display 1-2 DVI Interface (for M/M) 2-3 LVDS Interface (for KIOSK)	1-2																														
J13	Beep sound enable Short Beep sound enable Open Beep sound disable	Short																														
CLR_CMOS	CMOS Clear 1-2 CMOS Clear 2-3 Normal	2-3																														
SW-1	Panel selection for LVDS panel <table border="1" style="width: 100%; border-collapse: collapse;"> <thead> <tr> <th>1</th> <th>2</th> <th>3</th> <th>4</th> <th>Panel</th> </tr> </thead> <tbody> <tr> <td>OFF</td> <td>OFF</td> <td>OFF</td> <td>OFF</td> <td>12.1 inch SVGA</td> </tr> <tr> <td>ON</td> <td>OFF</td> <td>OFF</td> <td>OFF</td> <td>15 inch XGA</td> </tr> <tr> <td>OFF</td> <td>ON</td> <td>OFF</td> <td>OFF</td> <td>17 inch SXGA</td> </tr> <tr> <td>ON</td> <td>ON</td> <td>OFF</td> <td>OFF</td> <td>10.4 inch VGA</td> </tr> <tr> <td colspan="4">Other setting</td> <td>Reserved</td> </tr> </tbody> </table>	1	2	3	4	Panel	OFF	OFF	OFF	OFF	12.1 inch SVGA	ON	OFF	OFF	OFF	15 inch XGA	OFF	ON	OFF	OFF	17 inch SXGA	ON	ON	OFF	OFF	10.4 inch VGA	Other setting				Reserved	1...OFF 2...OFF 3...OFF 4...OFF
1	2	3	4	Panel																												
OFF	OFF	OFF	OFF	12.1 inch SVGA																												
ON	OFF	OFF	OFF	15 inch XGA																												
OFF	ON	OFF	OFF	17 inch SXGA																												
ON	ON	OFF	OFF	10.4 inch VGA																												
Other setting				Reserved																												

XL² Motherboard Specifications

Features		XL ² type	Comments
CPU		Core 2 Duo (Merom) processor 2.2GHz	Auto detection for FSB speed up to 800MHz
Core Chipset		GME965 + ICH8MDO	
System memory	RAM slots	2 x 200 pins SO-DIMM	
	Supported DRAM	DDR2 SDRAM 667 / 533	
	DRAM capacity	512MB up to 2GB	
	DRAM ECC support	No	
	L2 Cache	Depends on CPU	
	BIOS ROM	Flash (FWH type)	BIOS Up grade from a file on the disk.
CRAM backup		On board Lithium battery	10 years, soldered on MB w/o socket
Graphic/Video	Chipset	Integrated on North bridge	The chipset is mounted on motherboard.
	VRAM	UME (64, 128, 256MB.& Max DVMT)	Selectable in BIOS
	Analog Interface	Yes	
	Digital Interface	LVDS (KIOSK type) DVI (MM type)	
	Supported Display	VGA/SVGA/XGA/SXGA/QXGA	
	Supported Color	16bit/32bit Color	
Sound/Audio	Controller	High Definition Audio Serial Link	
	Ext. Connector	Line OUT / MIC IN	
LAN	Interface	10Base-T/100BASE-TX/1000Base-T	
	Controller	Integrated on South Bridge	
	Wake-On LAN	Yes(S1/S3/S4/S5 resume support)	
I/O	Front USB	2 ports	Only 1 avail if Flash Mem used
	Rear USB	Max 8 ports	Depends on I/O Board Installed
	COM	Max 4 ports	Depends on I/O Board Installed
	Parallel	No	
	IrDA	No	
	Keyboard	PS/2 , USB	
	Mouse	PS/2 , USB	
	Floppy Disk I/F	No	External Only
HDD	SATA	Up to 2 pcs	
	speed	3 Gbps (SATA II)	
	RAID	Yes (BIOS setting)	
IDE	Interface	Up to UDMA5	This interface is for CD
	Ports	Primary Master	
	CD/DVD support	Yes	
Board Factor	Form factor	No standard	
	Riser card	No	
	AGP Slot	No	
Other features	Plug & Play	Yes	
	APM 1.2 Support	Yes	
	ACPI support	Yes	
	WFM1.1a support	Yes	Based on Remote boot and Wake on LAN function
	DMI 2.0 Support	Yes	
	PC99 Compliant	No	
	TPM 1.2	Yes	
	AC Failure restoration	Yes	
	LAN flash	Yes	
	BIOS flash	Yes	
	PXE boot (RIS)	Yes	
	SMBIOS 2.0	Yes	
	Features		XL ² type
Safety/EMI	CE/CB	Yes	
	FCC	Class A	FCC 47CFR Part 15 class A
	CCC	No	No support for China market

	UL/CSA	Yes	UL60950-1 1st Edition CAN/CSA-C22.2 No.60950-1-03 1st Edition
Reliability	MTBF	100,000 hours	
	HW- Monitoring	Yes	
	- CPU voltage	Yes	
	- CPU Thermal	Yes	
	- FAN Control	Yes (PSU FAN only)	
	- FAN Rotation monitor	Yes	
	- Chassis open	No	

APPENDIX C: I/O BOARDS

The following illustrations show the TeamPoS 3000 Option boards and the coinciding jumper configurations.

Combo Board

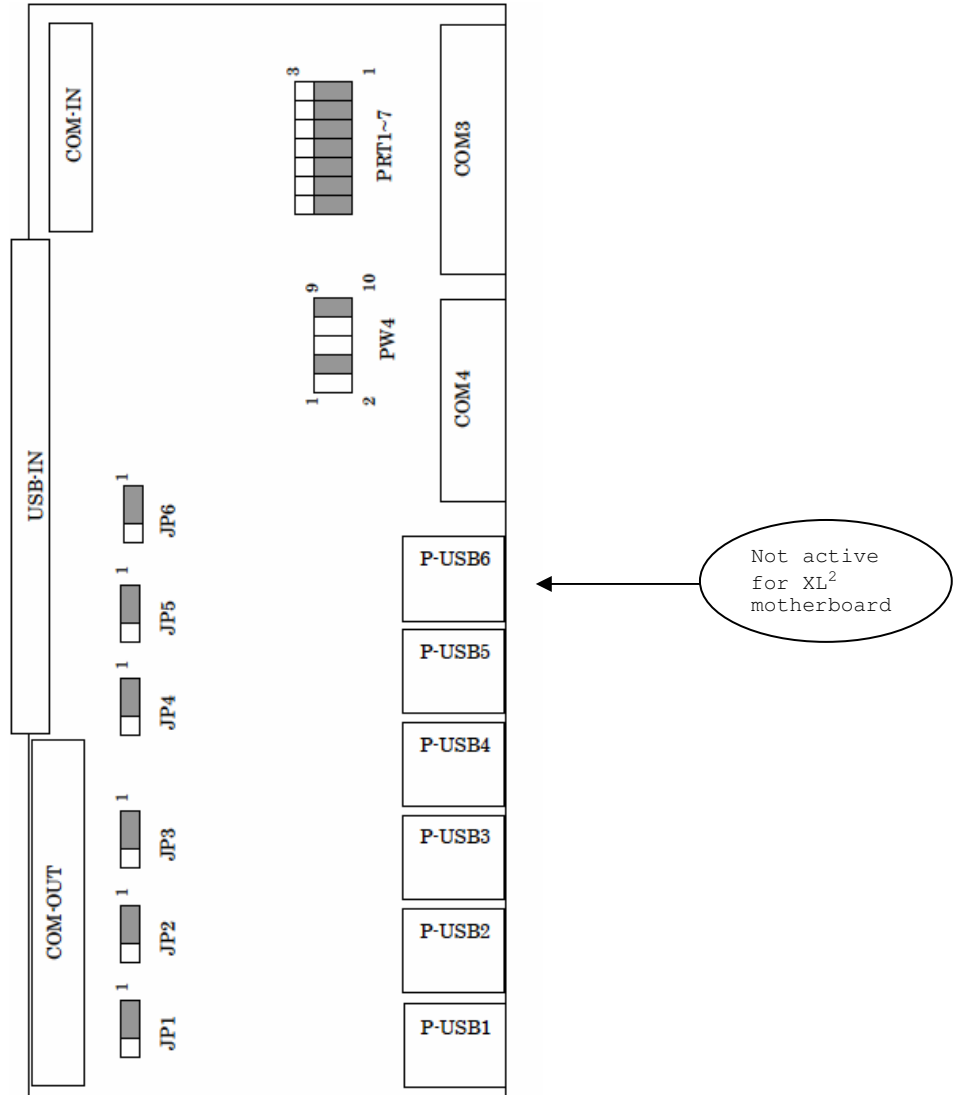

The jumper block with 7 connectors (PRT1-7) and the right most of the two jumper blocks (PW4) define the printer type to be used on COM3. The default for this jumper block is the Fujitsu printers. The default mode is with all 7 jumpers toward the metal strip. Move the 7 jumpers towards the wire harness connectors to support ESC POS printers. The jumper settings are shown below.

Jumper	Function	Default Setting
JP1	Power source selection for USB connector 1 1-2 Normal +5V 2-3 Standby +5V	1-2
JP2	Power source selection for USB connector 2 1-2 Normal +5V 2-3 Standby +5V	1-2
JP3	Power source selection for USB connector 3 1-2 Normal +5V 2-3 Standby +5V	1-2
JP4	Power source selection for USB connector 4 1-2 Normal +5V 2-3 Standby +5V	1-2
JP5	Power source selection for USB connector 4 1-2 Normal +5V 2-3 Standby +5V	1-2
JP6	Power source selection for USB connector 6 1-2 Normal +5V 2-3 Standby +5V	1-2
PW4	Signal selection for D-Sub 9 connector 1-2 RI 3-4 +5V 5-6 +12V 7-8 DCD 9-10 N.C.	1-2 Open 3-4 Short 5-6 Open 7-8 Open 9-10 Short
PRT1-7	Signal selection for D-Sub 9 connector 1-2 DTR 2-3 GND 4-5 GND 5-6 CTS 7-8 GND 8-9 DSR 10-11 N.C. 11-12 DCD 13-14 N.C. 14-15 RI 16-17 +5V 17-18 DTR 19-20 +5V 20-21 RTS	1-2 Short 4-5 Short 7-8 Short 10-11 Short 13-14 Short 16-17 Short 19-20 Short

The 5 connector jumper block (PW4) defines COM4.

The 7 connector jumper block (PRT1-7) defines the printer interface being used. For Epson, Citizen, and TPG (Axiohm) printers the jumpers should be set to 2-3, 5-6, 8-9, 11-12, 14-15, 17-18, and 20-21.

COM Board

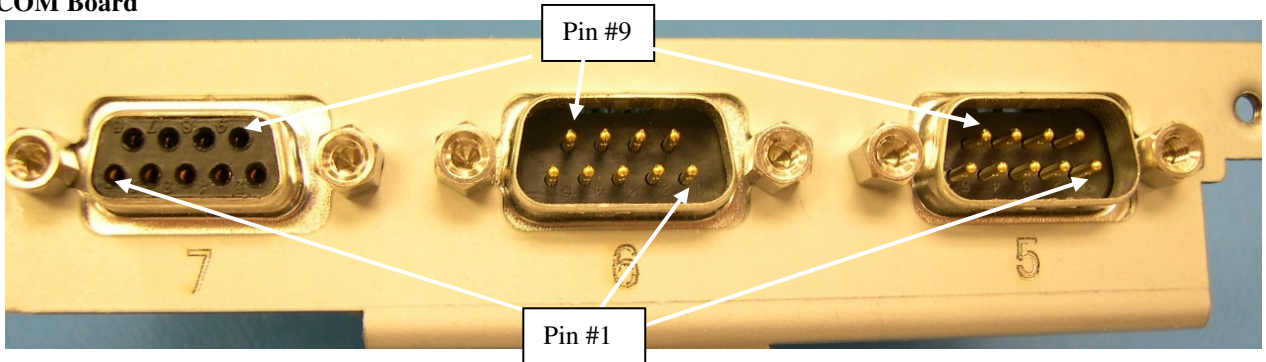

NOTE: This board is not supported on the XL² motherboard.

Pin	COM 7 Female Connector	COM 6 Male connector	COM 5 Male Connector
1	Ground	Data Carrier Detect (DCD)	Data Carrier Detect (DCD)
2	RX	RX	RX
3	TX	TX	TX
4	24V	DTR	DTR
5	Ground	Ground	Ground
6	+5V	DSR	DSR
7	RTS	RTS	RTS
8	CTS	CTS	CTS
9	Ground	RI or +5V depending upon jumper on PW2	RI or +5V depending upon jumper on PW1

There are two jumper blocks on the COM Card (PW1 for COM5 and PW2 for COM6). Each block will determine if a voltage or RI (ring) signal is on pin 9 of the DB9 connector and whether the Data Carrier Detect (DCD) signal is used on pin1. See chart on following page for jumper positions.

TP3000 COM PCB

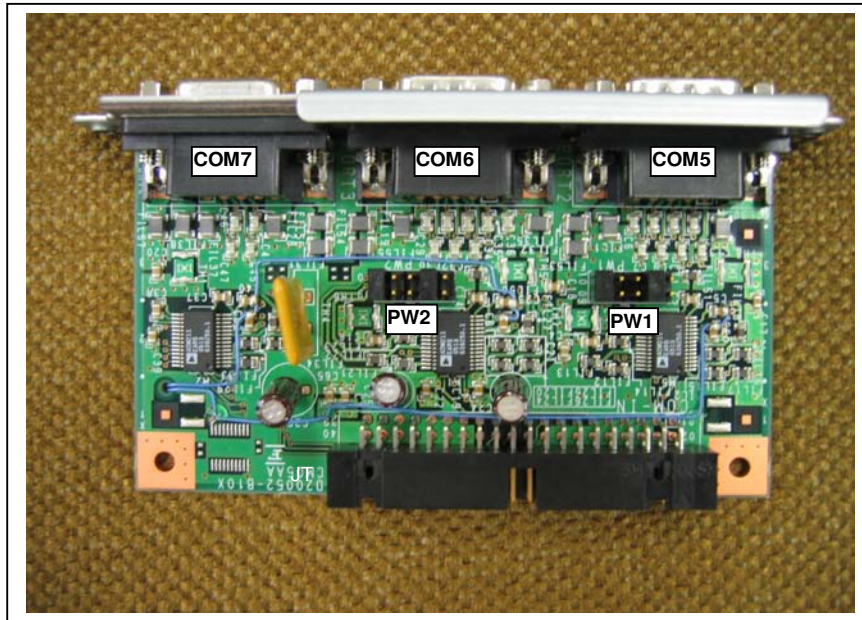

PW2 COM6	
1-2	RI
3-4	+5VSB
5-6	Do not use
7-8	DCD
9-10	NC

PW1 COM5	
1-2	RI
3-4	+5VSB
5-6	Do not use
7-8	DCD
9-10	NC

Caution: only one position of the first two options must be selected (RI, or +5VSB)
Pins 2, 4, and 6 of PW1 / PW2 are tied together and only one source must be used

NOTE: This board is not supported on the XL² motherboard.

USB Board

The third board is a stand alone board that fits in the same card slot as the COMBO card. This card cannot be used with either of the other two boards above. When this card is used a blanking plate is installed in the empty slot.

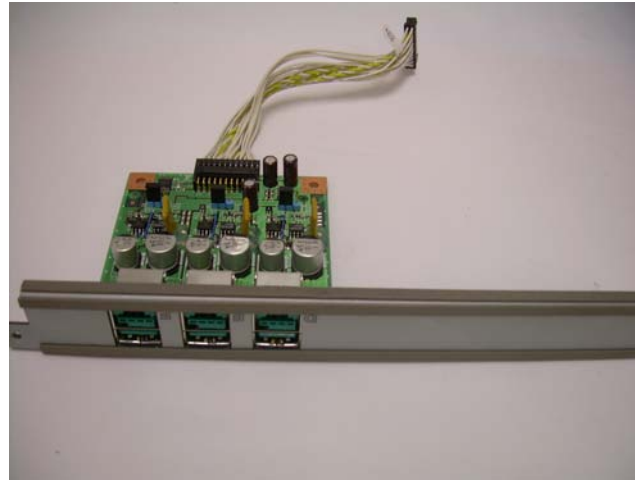

Front View

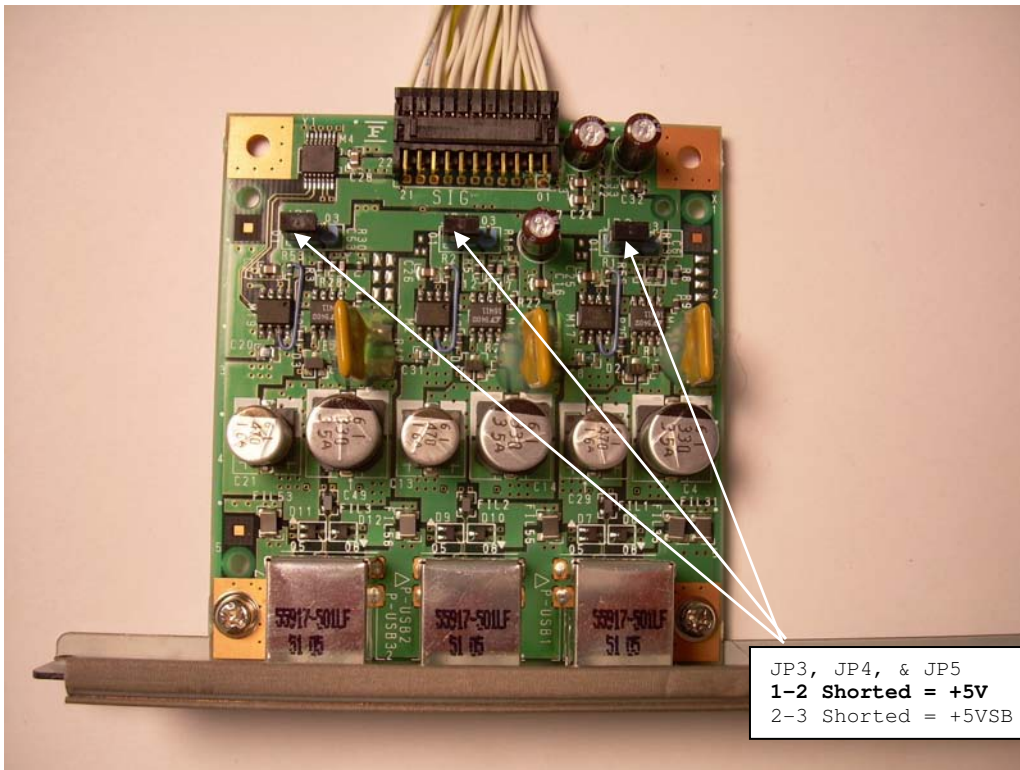

Top View

Rear Panel

There are three different interface boards or combo cards available on the XL model and two cards available on the XL² model. The picture below shows the rear of the XL terminal with two cards installed. The Combo cards provide support for both USB and legacy devices. To use COM Card on the XL model you must have Combo Card installed. The Combo Card can be used by itself or with COM Card on the XL model only. The third interface board contains three +12V powered USB ports. See the Installation and Maintenance Manual for removal and replacement of these cards.

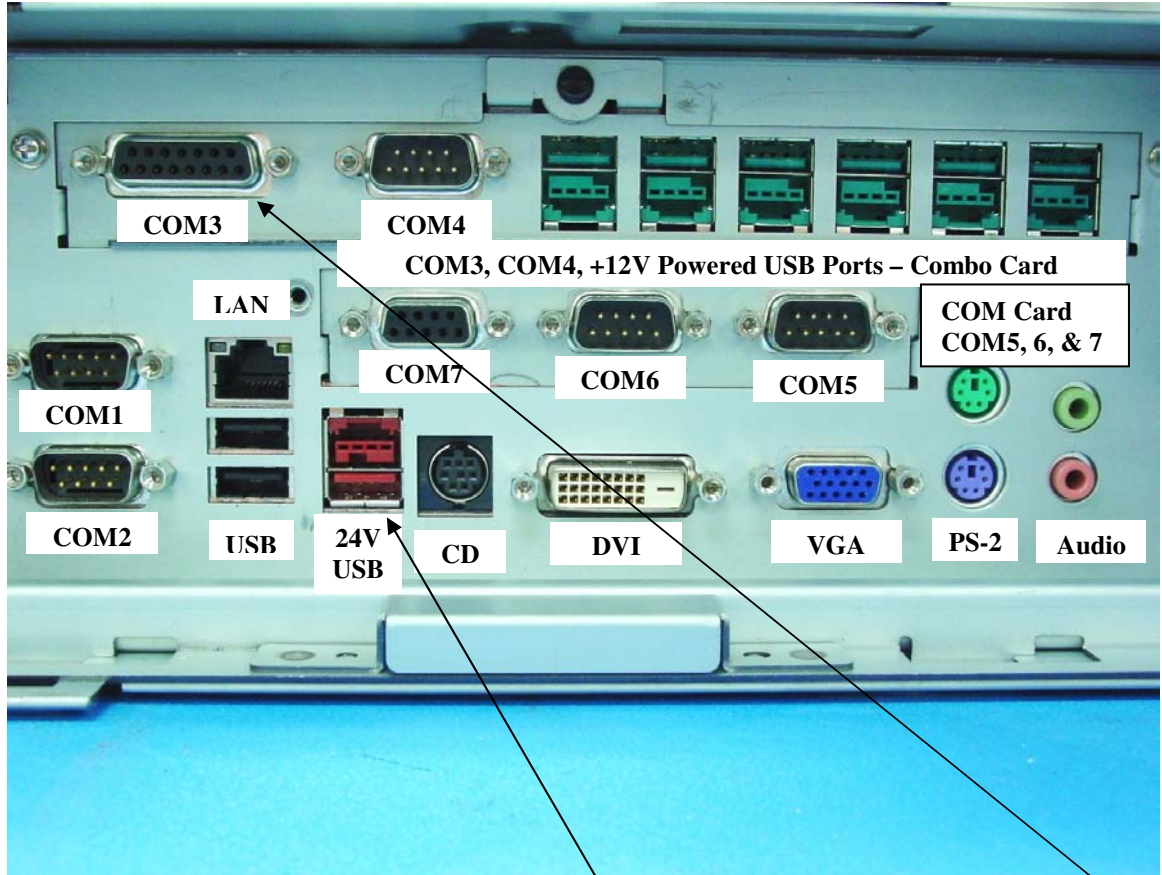

Note: Ports designated as Port “C” on the backplane (24V PUSB) and Port “3” on the Combo board(24V RS232) do not meet the UL Limited Power Source (LPS) requirements. These ports are limited to only allowing 24V retail POS RS232 or powered USB peripherals that do not exceed a rated current of 4 amps and are provided with a fire enclosure, rated Min. “V-1 or Metal”.

TeamPoS 3000 Pin Assignments - Backplane

	Cash Drawer	COM1 & 2	USB +24V Red powered USB connector	USB +12V Green powered USB connectors
1	+24V Return		5V USB Pwr	5V USB Pwr
2	Dwr1 Status		Data -	Data -
3	Dwr1 Kick		Data +	Data +
4	Gnd – dual CD		Gnd	Gnd.
5	Gnd		+24V Return	+12V Return
6	Gnd – Dual CD		+24V Pwr	+12V Pwr
7	Drw2 - Kick		+24V Pwr	+12V Pwr
8	Drw2 - Status		+24V Return	+12V Return
9	NC			
10				
11				
12				
13				
14				
15				

Other connectors are industry standard and need not be detailed in this document

Cash Drawer Plug

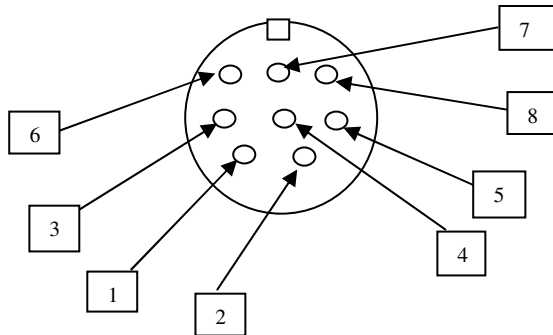

	Fujitsu Transaction Solutions	SUPPORT PLANNING GUIDE TeamPoS 3000 XL Terminal	SPG-06-002A
	Sustaining Engineering		Issue: 2.0
	San Diego, CA; Montreal QC		April 23, 2008

7. APPENDIX E: BIOS

The BIOS section is divided into two sections, one for the XL motherboard, and one for the XL² motherboard. The XL BIOS set-up instructions and settings are for BIOS level P09 on the original release of the TeamPoS 3000 terminal. The XL² BIOS set-up and settings are for P07 on the first release of this motherboard. The BIOS level is expected to change throughout the life of the terminal and therefore these readings may not necessarily reflect later versions of the BIOS. The latest BIOS version can be obtained from the FTP site at <ftp://ftp.ftxs.fujitsu.com/POS/POSSustaining/Retail/TeamPOS 3000>. If access to the ftp site is not possible, the latest BIOS should be available on the ftxs.fujitsu.com site under support.

Note: The FTP site requires a sign-on and password to gain access. Please see your technical support for access information.

If a motherboard is replaced in the field, it may be necessary to change the date and time and setup the BIOS for the customer's configuration. The following information shows the default screens from the factory.

Opening CMOS Setup Screen

Turn ON power and press the "F2" key while the terminal goes through the power on self test.(POST).

CMOS Settings

If this is a new motherboard it will be necessary to set the date and time before releasing the terminal to the customer. To change the date and time select STANDARD CMOS FEATURES and manually make changes by inserting the current date and time. Run "LOAD OPTIMIZED DEFAULTS" then "SAVE & EXIT SETUP." Changing other default settings may be done at this time if the customer has settings other than the default settings listed here. Changing settings that are not the default or not set for specific customer needs may adversely effect the operation of the unit.

In most cases, the CMOS default settings are adequate and do not require changing. Follow the instructions on the screen to select STANDARD CMOS SETUP. To change the time and date follow the instructions on the screen. Run LOAD OPTIMAL DEFAULTS located under the "EXIT" tab. Exit, saving settings. Changing other default settings can adversely effect the operation of the unit.

Note: The arrow [▶] indicates additional screens. Use [Enter] to advance to the next screen. Text shown in blue is either dynamic meaning it changes as the unit operates, or it is set for automatic mode and is not selectable in that mode.

In the instructions, information on how to change settings appears in the right column under "Item Help". Information appropriate to the item selected appears under "Menu Level".

XL² MOTHERBOARD BIOS SCREEN

Note: An arrow [▶] indicates additional screens. Use [Enter] to advance to the next screen. Text shown in blue is dynamic meaning it either changes as the unit operates, or it is set for automatic mode and is not selectable in that mode.

Phoenix TrustedCore™ Setup Utility						
Main	Advanced	Security	TPM State	Power	Boot	Exit
System Time: [09:46:01] System Date: [09/05/2007]					Item Specific Help	
Legacy Diskette A: [Disabled]						
▶ IDE Primary/Master [DW-224E-C-(PM)]						
▶ IDE Primary/Slave [None]						
▶ SATA Port 1 [HTS541040G9SA00-(S1)]						
▶ SATA Port 2 [None]						
▶ SATA Port 3 [None]						
Halt on [All, But Keyboard]						
Base Memory: 640 KB						
Extended Memory: 1038336 KB						
Total Memory: 1039360 KB						
F1	Help	↑ ↓	Select Item	-/+	Change Values	F9 Setup Defaults
Esc	Exit	← →	Select Menu	Enter	Select ▶ Submenu	F10 Save and Exit

Phoenix TrustedCore™ Setup Utility						
Main	Advanced	Security	TPM State	Power	Boot	Exit
IDE Primary/Master		[DW-224E-C-(PM)]			Item Specific Help	
Type:		[Auto]			User = you enter parameters of hard disk drive installed at this connection. Auto – autotypes hard-disk drive installed here CD-ROM = a CD-ROM drive is installed here. ATAPI Removable = removable disk drive is installed here.	
Multi-Sector Transfers:		[Disabled]				
LBA Mode Control:		[Disabled]				
32 Bit I/O		[Disabled]				
Transfer Mode:		[FPIO 4 / DMA 21				
Ultra DMA Mode:		[Mode 2]				
F1	Help	↑ ↓	Select Item	-/+	Change Values	F9 Setup Defaults
Esc	Exit	← →	Select Menu	Enter	Select ► Submenu	F10 Save and Exit

Phoenix TrustedCore™ Setup Utility						
Main	Advanced	Security	TPM State	Power	Boot	Exit
IDE Primary/Slave		[None]			Item Specific Help	
Type:	[Auto]		User = you enter parameters of hard disk drive installed at this connection.			
Multi-Sector Transfers:	[Disabled]		Auto – autotypes hard-disk drive installed here			
LBA Mode Control:	[Disabled]		CD-ROM = a CD-ROM drive is installed here.			
32 Bit I/O	[Disabled]		ATAPI Removable = removable disk drive is installed here.			
Transfer Mode:	[Standard]					
Ultra DMA Mode:	[Disabled]					
F1 Help	↑ ↓	Select Item	-/+	Change Values	F9	Setup Defaults
Esc Exit	← →	Select Menu	Enter	Select ▶ Submenu	F10	Save and Exit

Phoenix TrustedCore™ Setup Utility						
Main	Advanced	Security	TPM State	Power	Boot	Exit
Sata Port 1		[HTS541040G9SA00-(S1)]			Item Specific Help	
Type:	[Auto]		User = you enter parameters of hard disk drive installed at this connection.			
	LBA Format		Auto – autotypes hard-disk drive installed here			
Total Sectors:	78140160		CD-ROM = a CD-ROM drive is installed here.			
Maximum Capacity:	40008MB SATA1		ATAPI Removable = removable disk drive is installed here.			
Multi-Sector Transfers:	[16 Sectors]					
LBA Mode Control:	[Enabled]					
32 Bit I/O:	[Disabled]					
Transfer Mode:	[FPIO 4 / DMA 2]					
Ultra DMA Mode:	[Mode 5]					
F1 Help	↑ ↓	Select Item	-/+	Change Values	F9	Setup Defaults
Esc Exit	← →	Select Menu	Enter	Select ▶ Submenu	F10	Save and Exit

Phoenix TrustedCore™ Setup Utility							
Main	Advanced	Security	TPM State	Power	Boot	Exit	
Sata Port 2			[None]	Item Specific Help			
Type:		[Auto]	User = you enter parameters of hard disk drive installed at this connection.				
Multi-Sector Transfers:		[Disabled]	Auto – autotypes hard-disk drive installed here				
LBA Mode Control:		[Disabled]	CD-ROM = a CD-ROM drive is installed here.				
32 Bit I/O:		[Disabled]	ATAPI Removable = removable disk drive is installed here.				
Transfer Mode:		[Standard]					
Ultra DMA Mode:		[Disabled]					
F1	Help	↑ ↓	Select Item	-/+	Change Values	F9	Setup Defaults
Esc	Exit	← →	Select Menu	Enter	Select ▶ Submenu	F10	Save and Exit

Phoenix TrustedCore™ Setup Utility							
Main	Advanced	Security	TPM State	Power	Boot	Exit	
Sata Port 3			[None]	Item Specific Help			
Type:		[Auto]	User = you enter parameters of hard disk drive installed at this connection.				
Multi-Sector Transfers:		[Disabled]	Auto – autotypes hard-disk drive installed here				
LBA Mode Control:		[Disabled]	CD-ROM = a CD-ROM drive is installed here.				
32 Bit I/O:		[Disabled]	ATAPI Removable = removable disk drive is installed here.				
Transfer Mode:		[Standard]					
Ultra DMA Mode:		[Disabled]					
F1	Help	↑ ↓	Select Item	-/+	Change Values	F9	Setup Defaults
Esc	Exit	← →	Select Menu	Enter	Select ▶ Submenu	F10	Save and Exit

Phoenix TrustedCore™ Setup Utility								
Main	Advanced	Security	TPM State	Power	Boot	Exit		
<ul style="list-style-type: none"> ▶ CPU Feature ▶ GM965 Feature ▶ ICH8MDO Feature ▶ Super IO Feature ▶ Hardware Monitor Feature ▶ Other Feature <ul style="list-style-type: none"> IDAPIC [Enabled] Quick Boot [Enabled] Quiet Boot [Disabled] Boot Up NumLock Status [On] Summary Screen Show [Disabled] 						Item Specific Help		
F1	Help	↑ ↓	Select Item	-/+	Change Values	F9	Setup Defaults	
Esc	Exit	← →	Select Menu	Enter	Select ▶ Submenu	F10	Save and Exit	

Phoenix TrustedCore™ Setup Utility						
Main	Advanced	Security	TPM State	Power	Boot	Exit
CPU Feature				Item Specific Help		
Manufacturer		Intel				
Processor Type:		Intel ® Core™2 Duo				
Processor Speed:		2200 MHz				
CPU L2 Cache		[Enabled]				
Cache L1		32 KB				
Cache L2		4096 KB				
Thermal Control Circuit:		[TM2]				
Core Multi-Processing:		[Enabled]				
F1	Help	↑ ↓	Select Item	-/+	Change Values	F9 Setup Defaults
Esc	Exit	← →	Select Menu	Enter	Select ▶ Submenu	F10 Save and Exit

Phoenix TrustedCore™ Setup Utility						
Main	Advanced	Security	TPM State	Power	Boot	Exit
GM965 Feature				Item Specific Help		
IGD – Boot type		[HW Setting]				
IGD – Device 2:		[Enabled]				
IGD – Panel Scaling:		[Auto]				
DVMT 4.0 Mode:		[DVMT]				
Pre-Allocated Memory Size:		[8MB]				
Total Graphics Memory:		[256MB]				
DVMT Graphics Memory:		248MB				
F1	Help	↑ ↓	Select Item	-/+	Change Values	F9 Setup Defaults
Esc	Exit	← →	Select Menu	Enter	Select ▶ Submenu	F10 Save and Exit

Phoenix TrustedCore™ Setup Utility																				
Main	Advanced	Security	TPM State	Power	Boot	Exit														
ICH8MDO Feature				Item Specific Help																
<ul style="list-style-type: none"> ▶ USB Interface ▶ ICH Sata Pata Control Sub-Menu <table style="width: 100%; border-collapse: collapse;"> <tr> <td style="width: 60%;">High Definition Audio</td> <td style="text-align: right;">[Auto]</td> </tr> <tr> <td>Init Display First</td> <td style="text-align: right;">[Onboard/AGP]</td> </tr> <tr> <td>Onboard LAN Controller</td> <td style="text-align: right;">[Enabled]</td> </tr> <tr> <td>LAN ROM Control</td> <td style="text-align: right;">[Disabled]</td> </tr> <tr> <td>ICH8 SMBUS</td> <td style="text-align: right;">[Enabled]</td> </tr> <tr> <td>ICH8 IDE</td> <td style="text-align: right;">[Enabled]</td> </tr> <tr> <td>Reset Configuration Data:</td> <td style="text-align: right;">[No]</td> </tr> </table>							High Definition Audio	[Auto]	Init Display First	[Onboard/AGP]	Onboard LAN Controller	[Enabled]	LAN ROM Control	[Disabled]	ICH8 SMBUS	[Enabled]	ICH8 IDE	[Enabled]	Reset Configuration Data:	[No]
High Definition Audio	[Auto]																			
Init Display First	[Onboard/AGP]																			
Onboard LAN Controller	[Enabled]																			
LAN ROM Control	[Disabled]																			
ICH8 SMBUS	[Enabled]																			
ICH8 IDE	[Enabled]																			
Reset Configuration Data:	[No]																			
F1	Help	↑ ↓	Select Item	-/+	Change Values	F9 Setup Defaults														
Esc	Exit	← →	Select Menu	Enter	Select ▶ Submenu	F10 Save and Exit														

Phoenix TrustedCore™ Setup Utility																						
Main	Advanced	Security	TPM State	Power	Boot	Exit																
USB Interface				Item Specific Help																		
<table style="width: 100%; border-collapse: collapse;"> <tr> <td style="width: 60%;">Legacy USB Support:</td> <td style="text-align: right;">Enabled</td> </tr> <tr> <td>USB 2.0 Controller (Channel A)</td> <td style="text-align: right;">[Enabled]</td> </tr> <tr> <td>ICH8 USB#1</td> <td style="text-align: right;">Enabled</td> </tr> <tr> <td>ICH8 USB#2</td> <td style="text-align: right;">[Enabled]</td> </tr> <tr> <td>ICH8 USB#3</td> <td style="text-align: right;">[Enabled]</td> </tr> <tr> <td>USB 2.0 Controller (Channel B)</td> <td style="text-align: right;">Enabled</td> </tr> <tr> <td>ICH8 USB#4</td> <td style="text-align: right;">[Enabled]</td> </tr> <tr> <td>ICH8 USB#5</td> <td style="text-align: right;">[Enabled]</td> </tr> </table>							Legacy USB Support:	Enabled	USB 2.0 Controller (Channel A)	[Enabled]	ICH8 USB#1	Enabled	ICH8 USB#2	[Enabled]	ICH8 USB#3	[Enabled]	USB 2.0 Controller (Channel B)	Enabled	ICH8 USB#4	[Enabled]	ICH8 USB#5	[Enabled]
Legacy USB Support:	Enabled																					
USB 2.0 Controller (Channel A)	[Enabled]																					
ICH8 USB#1	Enabled																					
ICH8 USB#2	[Enabled]																					
ICH8 USB#3	[Enabled]																					
USB 2.0 Controller (Channel B)	Enabled																					
ICH8 USB#4	[Enabled]																					
ICH8 USB#5	[Enabled]																					
F1	Help	↑ ↓	Select Item	-/+	Change Values	F9 Setup Defaults																
Esc	Exit	← →	Select Menu	Enter	Select ▶ Submenu	F10 Save and Exit																

Phoenix TrustedCore™ Setup Utility							
Main	Advanced	Security	TPM State	Power	Boot	Exit	
ICH Sata Pata Control Sub-Menu				Item Specific Help			
SATA – Device 31, Function 2: [Enhanced] Native Mode Operation: [Auto] SATA RAID Enable: [Enabled]							
F1	Help	↑ ↓	Select Item	-/+	Change Values	F9	Setup Defaults
Esc	Exit	← →	Select Menu	Enter	Select ▶ Submenu	F10	Save and Exit

All options are shown here, however on the BIOS screens it will be necessary to scroll down to see all the options:

Phoenix TrustedCore™ Setup Utility						
Main	Advanced	Security	TPM State	Power	Boot	Exit
Super IO Feature				Item Specific Help		
COMM1: [Enabled] Base I/O address: [3F8] Interrupt: [IRQ 4] COMM2: [Enabled] Base I/O address: [2F8] Interrupt: [IRQ 3] COMM3: [Enabled] Base I/O address: [3E8] Interrupt: [IRQ 5] COMM4: [Enabled] Base I/O address: [2E8] Interrupt: [IRQ 7] Powered COM1 Cofiguration [Disabled] Powered COM2 Cofiguration [Disabled] PS/2 Mouse Support [Enabled] ▶ Console Redirection						
F1 Help	↑ ↓	Select Item	-/+	Change Values	F9	Setup Defaults
Esc Exit	← →	Select Menu	Enter	Select ▶ Submenu	F10	Save and Exit

All options are shown here, however on the BIOS screens it will be necessary to scroll down to see all the options:

Phoenix TrustedCore™ Setup Utility							
Main	Advanced	Security	TPM State	Power	Boot	Exit	
Hardware Monitor Feature			Item Specific Help				
Hardware Monitoring			[Enabled]				
CPU Temperature			35 C/095F				
Alarm/Shutdown			[Shutdown]				
Temperature			[90C / 194F]				
PSU Temperature			30 C/086F				
Alarm/Shutdown			[Shutdown]				
Temperature			[70C / 158F]				
System Temperature			28 C/082F				
Alarm/Shutdown (High)			[Disabled]				
Temperature			[65C / 149F]				
Low Temperature			[Disabled]				
Temperature			[5C / 41F]				
FAN1 (CPU) Speed			N/A				
FAN Control			[Disabled]				
CPU Temperature			[80C / 176F]				
System Temperature			[45C / 113F]				
Alarm/Shutdown			[Disabled]				
Speed			[4000RPM]				
FAN2 (PSU) Speed			3068 RPM				
Fan Control			[POS]				
CPU Temperature			[80C / 176F]				
System Temperature			[45C / 113F]				
PSU Temperature			[55C / 131F]				
Alarm/Shutdown			[Shutdown]				
Speed			[2000RPM]				
Vcore			0.928 V				
+1.05V			1.040 V				
+3.3V			3.424 V				
+5V			5.157 V				
+5V_STBY			5.103 V				
+12V			11.65 V				
VBAT			3.264 V				
F1	Help	↑ ↓	Select Item	-/+	Change Values	F9	Setup Defaults
Esc	Exit	← →	Select Menu	Enter	Select ► Submenu	F10	Save and Exit

All options are shown here, however on the BIOS screens it will be necessary to scroll down to see all the options:

Phoenix TrustedCore™ Setup Utility						
Main	Advanced	Security	TPM State	Power	Boot	Exit
Other Feature			Item Specific Help			
<p>▶ System Information</p> <p>Auto Detect PCI Clk [Enabled] Spread Spectrum [Enabled]</p> <p>DMI Event Log [Enabled] Clear all DMI event logs [No] View DMI event log [Enter] Mark DMI events as read [Enter]</p> <p>Watch Dog Timer Select [Disabled] Self cleaning function [Disabled] Near Day Range [One Week] Clear Previous Date [Enter] Previous Clean Date ????</p> <p>Prevent miswriting MAC address [Disabled]</p>						
F1	Help	↑ ↓	Select Item	-/+	Change Values	F9
Esc	Exit	← →	Select Menu	Enter	Select ▶ Submenu	F10
						Setup Defaults
						Save and Exit

Phoenix TrustedCore™ Setup Utility						
Main	Advanced	Security	TPM State	Power	Boot	Exit
System Information				Item Specific Help		
BIOS Version: Yosemite-P05 Product Name: FujitsuTP3000 Build Date: 01/10/08 Processor Type: Intel ® Core™ 2 DUO Processor Speed: 2200 MHz Processor Count: 1 Memory DIMM1: 1024 MB Memory DIMM2: Not Installed MAC Address: 00 1D 7D 26 0C 0F						
F1 Help	↑ ↓	Select Item	-/+	Change Values	F9	Setup Defaults
Esc Exit	← →	Select Menu	Enter	Select ▶ Submenu	F10	Save and Exit

Phoenix TrustedCore™ Setup Utility						
Main	Advanced	Security	TPM State	Power	Boot	Exit
Supervisor Password Is: Clear				Item Specific Help		
User Password Is: Clear						
Set Supervisor Password [Enter]						
Set User Password [Enter]						
Password on boot: [Disabled]						
TPM Support [Enabled }						
F1 Help	↑ ↓	Select Item	-/+	Change Values	F9	Setup Defaults
Esc Exit	← →	Select Menu	Enter	Select ▶ Submenu	F10	Save and Exit

Phoenix TrustedCore™ Setup Utility							
Main	Advanced	Security	TPM State	Power	Boot	Exit	
					Item Specific Help		
Current TPM State:		Disabled and Deactivated					
Change TPM State		[No Change]					
F1	Help	↑ ↓	Select Item	-/+	Change Values	F9	Setup Defaults
Esc	Exit	← →	Select Menu	Enter	Select ▶ Submenu	F10	Save and Exit

Phoenix TrustedCore™ Setup Utility							
Main	Advanced	Security	TPM State	Power	Boot	Exit	
					Item Specific Help		
ACPI Function		[Enabled]					
Disable ACPI_Sx:		[None]					
Soft-Off by PWR		[Delay 4 Sec.]					
USB KB Wake-Up from S3		[Disabled]					
Wake-Up by PME		[Disabled]					
Resume On Time:		[Off]					
Resume Time:		[00:00:00]					
After Power Failure:		[Last State]					
F1	Help	↑ ↓	Select Item	-/+	Change Values	F9	Setup Defaults
Esc	Exit	← →	Select Menu	Enter	Select ▶ Submenu	F10	Save and Exit

All options are shown here, however on the BIOS screens it will be necessary to scroll down to see all the options:

Phoenix TrustedCore™ Setup Utility						
Main	Advanced	Security	TPM State	Power	Boot	Exit
					Item Specific Help	
Boot priority order: 1: USB FDC: 2: IDE CD: DW-224E-C-(PM) 3: USB CDROM: 4: PCI SCSI: HTS541040G9SA00 5: IDE HDD: 6: 7: Excluded from boot order: : USB KEY: : USB HDD: : USB ZIP: : USB LS120: : PCI BEV: : Other USB: : PCI: : Legacy Network Card : Legacy : 1394 CDROM:						
F1	Help	↑ ↓	Select Item	-/+	Change Values	F9
Esc	Exit	← →	Select Menu	Enter	Select ► Submenu	F10
					Setup Defaults	
					Save and Exit	

Phoenix TrustedCore™ Setup Utility							
Main	Advanced	Security	TPM State	Power	Boot	Exit	
Exit Saving Changes Exit Discarding Changes Load Setup Defaults Discard Changes Save Changes					Item Specific Help		
F1	Help	↑ ↓	Select Item	-/+	Change Values	F9	Setup Defaults
Esc	Exit	← →	Select Menu	Enter	Select ▶ Submenu	F10	Save and Exit

8. APPENDIX F: INTELLIGENT PIN (15000099)

Intelligent PINs will consist of 15 alphanumeric characters. Each character will represent a TeamPoS 3000 option.

Value	Part Number	Brief Description
First Digit		Chassis Option
A	11000283	TP3K CNTLR/COMPACT/WHT - 10/100 LAN
B	11000284	TP3K CNTLR/COMPACT/BLK – 10/100 LAN
C	11000285	TP3K CNTLR/STANDARD/WHT – 10/100 LAN
D	11000286	TP3K CNTLR/STANDARD/BLK – 10/100 LAN
E	11002086	TP3K CNTLR/COMPACT/WHT - 1GB LAN
F	11002087	TP3K CNTLR/COMPACT/BLK – 1GB LAN
G	11002088	TP3K CNTLR/STANDARD/WHT – 1GB LAN
H	11002089	TP3K CNTLR/STANDARD/BLK – 1GB LAN
Second Digit		Motherboard
M	11000021	OPN TP3K XL Motherboard/SHE
Y	11001590	OPN TP3K XL ² Motherboard
Third Digit		CPU
1	11000027	OPN TP3K CPU/1.3 Celeron M
2	11000028	OPN TP3K CPU/1.5 Celeron M
3	11000029	OPN TP3K CPU/1.6 Pentium M
4	11000241	OPN TP3K CPU/2.0 Pentium M
5	11001772	OPN TP3K CPU/2.0 CELERON M550
6	11001774	OPN TP3K 2.2G CORE 2 DUO T7500
7	11002049	OPN TP3K 1.8G CORE 2 DUO T7100
Forth Digit		Memory
1	11000022	OPN TP3K Memory/DDR/256MB
2	11000023	OPN TP3K Memory/DDR/512MB
4	11000024	OPN TP3K Memory/DDR/1GB
5	11000095	OPN TP3K Memory/DDR/1GB X 2=2GB
6	11001767	OPN TP3K Memory/SOD/DDR2/512MB
7	11001768	OPN TP3K Memory/SOD/DDR2/1GB
8	11001769	OPN TP3K Memory/SOD/DDR2/1GB X 2=2GB
9	11001770	OPN TP3K Memory/SOD/DDR2/2GB
A	11001792	OPN TP3K Memory/SOD/DDR2/2GB X 2=4GB

Fifth Digit

0	11000287
1	11000042
3	11000292
4	11000043

I/O board options

No I/O board(2 blank panels)
OPN TP3K PUBS/3 12 VDC Ports
OPN, I/O BOARD, COMBO and COM (XL Only)
OPN TP3K Combo I/O Board

Sixth Digit

0	N/A
1	11000030
2	11001556

1st Hard Disk

OPN, No HDD
OPN TP3K HDD ASY/2.5"/40GB (XL Only)
OPN TP3K HDD ASY/2.5"/80GB

Seventh Digit

0	N/A
	11000030
	11001556
A	N/A
B	N/A
C	N/A

2nd Hard Disk

OPN, No 2nd HDD
OPN TP3K HDD ASY/2.5"/40GB (XL Only)
OPN TP3K HDD ASY/2.5"/80GB
RAID 0 (2 nd Drive same as 1 st in 6 th digit)
RAID 1 (2 nd Drive same as 1 st in 6 th digit)
BIOS Set UP for No RAID (C & D HDD)

Eighth Digit

0	N/A
1	11000039
2	11000040
3	11000041

Battery Backup

No Battery Backup
OPN TP3K Batt/Integrated/3 yr
OPN TP3K Batt/Integrated/6 yr
OPN TP3K Extended Battery Backup

Ninth Digit

0	None
	OS-WIN2K-3KXL965
4	OS-WIN2K-3KXL855
	OS-XPPRO-3KXL965
6	OS-XPPRO-3KXL855
	OS-XPECS-3KXL965
7	OS-XPECS-3KXL855
	OS-XPE-3KXL965
9	OS-XPE-3KXL855
	OS-W2K3S-3KXL965
A	OS-W2K3S-3KXL855
	OS-XPPROUNR-3KXL965
B	OS-XPPROUNR-3KXL855

Operating System NOTE: OS is dependent upon motherboard Installed

No OS System
OEM Windows2000 Pro for XL ² , Preloaded
OEM Windows2000 Pro for XL, Preloaded
OEM Windows XP Pro for XL ² , Preloaded
OEM Windows XP Pro for XL, Preloaded
OEM Windows XPe for XL2, Server Downloaded
OEM Windows Xpe for XL, Server Downloaded
OEM Windows XP Embedded for XL2, Preloaded
OEM Windows XP Embedded for XL, Preloaded
Win2003 SVR for XL2 w/5 CAL EMB, preloaded
Win2003 SVR for XL w/5 CAL EMB, preloaded
WXPPRO OEM Unrestricted for XL2 OS
WXPPRO OEM Unrestricted for XL OS

	Fujitsu Transaction Solutions	SUPPORT PLANNING GUIDE TeamPoS 3000 XL Terminal	SPG-06-002A
	Sustaining Engineering		Issue: 2.0
	San Diego, CA; Montreal QC		April 23, 2008

	OS-WEPOS-3KXL965	WEPOS OS for XL ²
W	OS-WEPOS-3KXL855	WEPOS OS for XL
	OS-VISTAB-3KXL965	Vista Business for XL ² , Preloaded
V	OS-VISTAB-3KXL855	Vista Business for XL, Preloaded

Tenth Digit

0	N/A
1	11000031
2	11000032
3	11000033
4	11000034

CD Drive Option

No CD Drive
OPN TP3K CD-R ASY/SW/WHT
OPN TP3K CD-R ASY/SW/BLK
OPN TP3K CD-RW/DVD/ASY/SW/WHT
OPN TP3K CD-RW/DVD/ASY/SW/BLK

Eleventh Digit

0	None
1	11000044
2	TBD
3	TBD
4	TBD
5	TBD
6	11000049

Power Cord

No Power Cord
CBL TP3K Mains/U.S./WHT
CBL TP3K Europe, non-UK,WHT
CBL TP3K UK,WHT
CBL TP3K Australia, So Amer,WHT
CBL TP3K So Africa, BLK
CBL TP3K Mains/U.S./BLK

Twelfth Digit

0	N/A
1	11002277

Spare

Spare
Flash Memory, 1GB

Thirteenth Digit

0	N/A
---	-----

Spare

Spare

Fourteen Digit

0	N/A
L	11000054
Z	11000055

LAN Option

No Wireless Option
Wireless LAN 802.11 A/B/G/PCI/ANT
OPN LAN ETH 10/100 NET CARD

Fifteenth Digit

0	N/A
R	N/A

RoHS Compliance

Not RoHS Compliant
RoHS Compliant